

Order Number
63808-2700

molex[®]

Application Tooling Specification

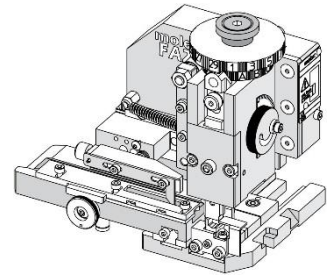

FEATURES

- Applicator designed to industry-standard mounting and 135.80mm (5.346") shut height
- Quick setup time; plus, the crimp height, track and feed adjustments can be set without removing the applicator from the press
- Fine adjustment allows users to achieve target with little effort by adjusting in increments of .015mm (.0006") for conductor crimp height and .025mm (.001") for insulation height
- Fine adjustment of the bend is achieved using the bend control adjust dial
- Independent adjustment rings allow users to quickly adjust the conductor or insulation crimp height without affecting each other
- Directly adapts to most automatic wire processing machines

SCOPE

Products: MX150 18 Grip Blade Terminals: 20 AWG wire.

Terminal Series No.	Terminal Order No.	Wire		Insulation Diameter		Strip Length	
		Wire Type	Wire Size	mm	In.	mm	In.
33000	33000-1002	GXL	20 AWG	1.60-2.54	.063-.100	4.70-5.60	.185-.220
33011	33011-0004						
34782	33011-3002	TXL	20 AWG	1.60-2.54	.063-.100	4.70-5.60	.185-.220
	34782-1002						

DEFINITION OF TERMS

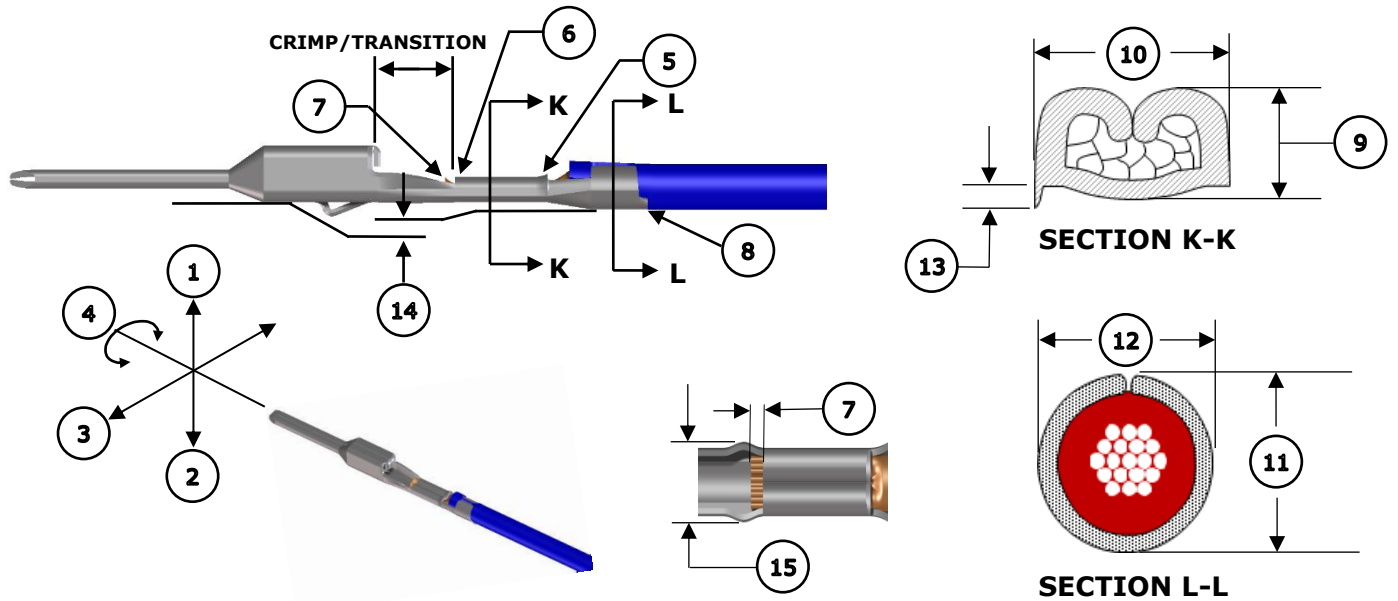

CRIMP SPECIFICATIONS

The following crimp specifications are based on document AS-33000-001 Rev E:

Feature	Requirement					
1. Bend Up	3° Max					
2. Bend Down	3° Max					
3. Twist	3° Max					
4. Roll	3° Max					
5. Bell Mouth Rear	0.30-0.70mm (.012-.028")					
6. Bell Mouth Front	Not Applicable					
7. Conductor Brush	0.40mm (.016") Not to extend above conductor crimp					
8. Cut-Off Tab	0.50mm (.020") Max					
Conductor Crimp	Wire Type	Wire Size	9. Crimp Height		10. Crimp Width	
	TXL	20 AWG	1.10-1.20mm	.043-.047 in.	2.05-2.25mm	.081-.089 in.
	GXL	20 AWG	1.10-1.20mm	.043-.047 in.		
Insulation Crimp	Wire Type	Wire Size	11. Crimp Height		12. Crimp Width	
	TXL	20 AWG	1.80-2.00mm	.071-.079 in.	2.00-2.20mm	.079-.087 in.
	GXL	20 AWG	1.90-2.10mm	.075-.083 in.	2.20-2.40mm	.087-.094 in.
Pull Force	Wire Type	Wire Size	Minimum Force		To be measured with no influence from the insulation crimp.	
	TXL	20 AWG	75 N	16.9 lb.		
	GXL	20 AWG	75 N	16.9 lb.		
13. Conductor Anvil Flash	0.10mm (.004") Max					
14. Insulation Grip Step	0.20-0.40mm (.008-.016") Max					
15. Crimp Bulge	2.55mm (.100") Max within the crimp/transition area					

NOTES

Applicator Notes

- This applicator is for automatic wire processor use only.
- This applicator does not include a cutting insert.
- Installing a cutting insert will cause jamming in this applicator.

CUTTING INSERT

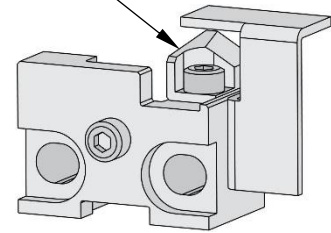

Specification Notes

- It is very important that the brush length is consistently within specification for this sealed connector system to work properly.
- This applicator should only be run in a properly set up wire processor to consistently achieve the brush length.

General Notes

1. Molex recommends that an extra perishable tooling kit be maintained at your facility.
2. Verify tooling alignment by hand cycling the press and applicator before crimping under power. Check that all screws are tight.
3. Slugs, terminals, dirt and oil should be kept clear of the work area.
4. Wear safety glasses at all times.
5. For recommended maintenance, refer to the FA2 manual (TM-638080200).
6. Molex recommends crimping standard copper wire only.
7. Lubrication must be used when crimping gold and select gold terminals to prevent terminals from sticking in the conductor punch. Use 63801-7240 oiler or equivalent.

WARNINGS

CAUTION: This applicator must be installed in a press with a standard shut height of 135.80mm (5.346"). Tooling damage could result at a lower setting.

CAUTION: To prevent injury, never operate this applicator without the guards supplied with the press or wire-processing machine in place. Reference the press or wire processing manufacturer's instruction manual.

CAUTION: Molex tooling crimp specifications are valid only when used with Molex terminals and tooling manufactured by Molex and sold by Molex or authorized distributors ("Molex Tooling"). When using tooling other than Molex Tooling with Molex-specific connector systems listed in our ATS documents, the Molex Tooling qualification does not apply, and the responsibility for full qualification of the connector system is that of the customer. Molex accepts no liability for connector performance or tooling support where tooling other than Molex Tooling is used or where Molex Tooling is modified.

PARTS LIST

FA2 Applicator 63808-2700				
Item	Order No.	Engineering No.	Description	Quantity
Perishable Tooling				
	63808-2770	63808-2770	Tool Kit (All "Y" Items)	Ref
1	63454-0171	63454-0171	Insulation Punch	1 Y
2	63457-0117	63457-0117	Conductor Punch	1 Y
3	63456-2002	63456-2002	Insulation Anvil	1 Y
4	63455-0145	63455-0145	Conductor Anvil	1 Y
5	63443-0034	63443-0034	Cut-Off Plunger	1 Y
Non-Perishable Components				
6	63443-0128	63443-0128	Front Plunger Retainer	1
7	11-24-1067	4996-4	Cut-Off Plunger Spring	1
8	63443-0117	63443-0117	Front Scrap Chute	1
9	63443-7502	63443-7502	Anvil Mount	1
10	63443-0090	63443-0090	Wire Stop Assembly	1
11	63443-3601	63443-3601	Front Plunger Striker	1
12	63443-3702	63443-3702	Wire Hold Down Plunger	1
13	63600-5776	63600-5776	Nose Hold Down	1
14	63600-5775	63600-5775	Nose Hold Down Shank	1
15	63443-4714	63443-4714	Terminal Guide	1
16	63443-7403	63443-7403	Hold Down Block	1
17	63808-0229	63808-0229	Bend Adjust Dial	1
18	63600-4387	63600-4387	Dial Indicator Plate	1
Frame				
19	63808-0200	63808-0200	Applicator Core	1
20	63443-4601	63443-4601	Track	1
21	63443-4602	63443-4602	Carrier Cover	1
22	63443-4801	63443-4801	Drag Pad	1
23	63808-0197	63808-0197	Mechanical Feed Assembly	1
24	63808-0297	63808-0297	Feed Cam	1
Hardware				
25	—	—	M2.5 x 4 SHCS	1*
26	—	—	M3 Flat Washer Hard	1*
27	—	—	M3 Inner Tooth Lock Washer	1*
28	—	—	M3 x 3 SSS	2*
29	—	—	M3 x 6 BHCS	2*
30	—	—	M3 x 12 SHCS	4*
31	—	—	M4 x 6 SHCS	1*
32	—	—	M4 x 6 SSS	1*
33	—	—	M4 x 8 SHCS	2*
34	—	—	M4 x 50 SHCS	2*
35	—	—	M5 x 12 SHCS	1*
36	—	—	#10-32UNF x .25" SHCS	1*
*Fastener parts can be purchased through most industrial suppliers by using the description in the table above.				

ASSEMBLY DRAWING

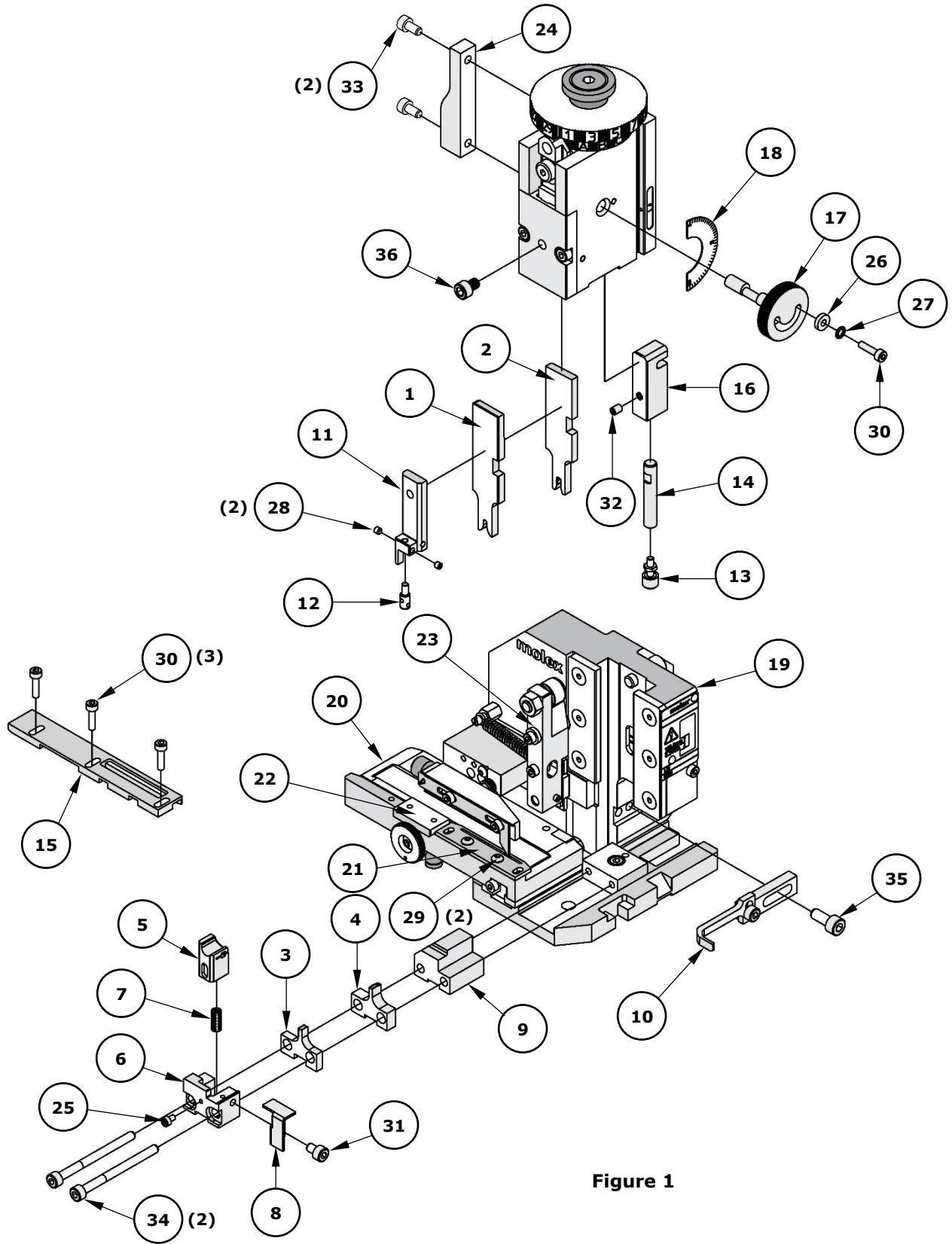

Figure 1

FACTORY SETTINGS

Feed Pawl Assembly

The FA2 applicator number 63808-2700 ships with the following factory settings. See Figure 2:

- The feed pawl shaft and M3 screw that holds the feed pawl spring are in position 2.
- The pin is in position B.

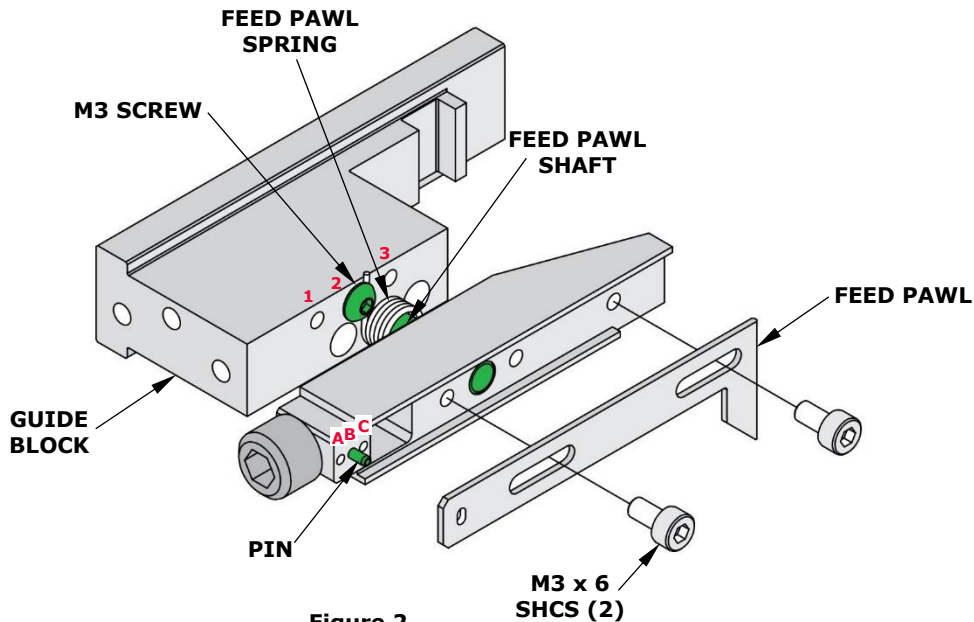

Figure 2

Note

This information is included as a reference only. Each applicator is configured and tested by Molex prior to shipping, and the above settings were used to produce the included sample crimps.

Third Dial/Ram Assembly

○ Indicates item number on the Parts List and Assembly Drawing

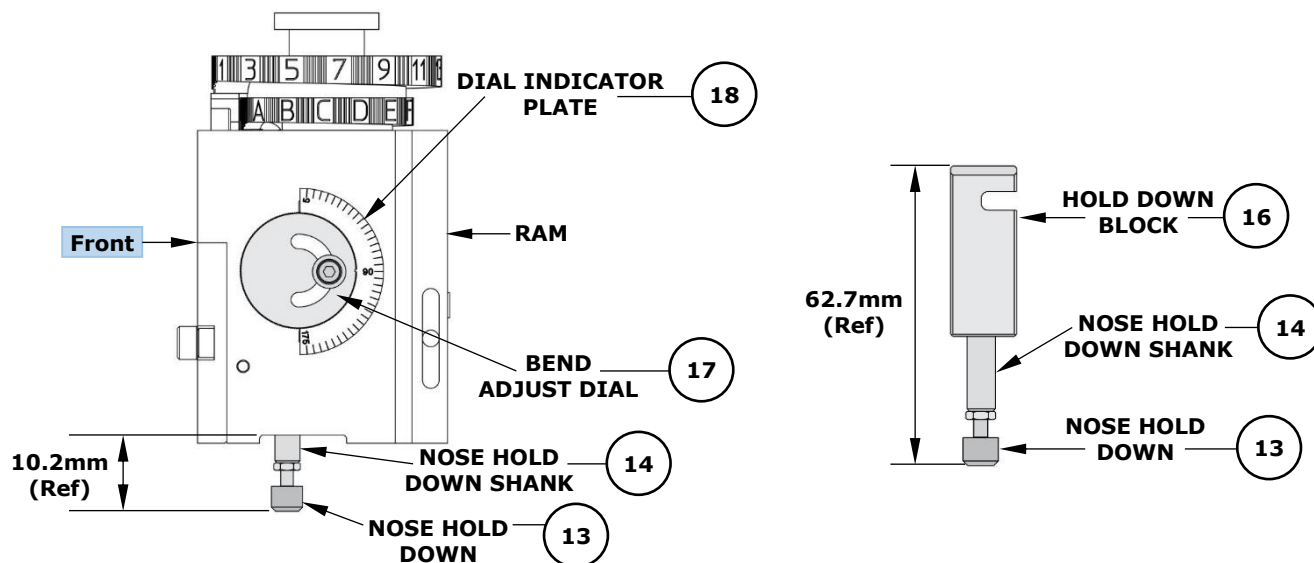

Application Tooling Support

Phone: (402) 458-TOOL (8665)

E-Mail: applicationtooling@molex.com

Website: www.molex.com/applicationtooling

Molex is a registered trademark of Molex, LLC in the United States of America and may be registered in other countries; all other trademarks listed herein belong to their respective owners.