

# ALEV100 Series DC Contactor Specification



## Application

- Power supply / motor control, circuit insulation, circuit protection and safety devices for industrial machinery
- Charging pill, Electric vehicle etc.

## Features

### HIGH CURRENT AND HIGH VOLTAGE

Nitrogen sealed contacts to minimize arcing, up to 750VDC load is available.

### COMPACT STRUCTURE, LOW NOISE

Contact design yields reduced unit size, low noise while carrying or switching current.

### HIGH SAFETY

There is no arc leakage due to tight sealing.

### HIGH CONTACT RELIABILITY

Stable contact resistance no matter how harsh the environment with sealed contacts

### NO SPECIAL MOUNTING REQUIREMENT

Light weight actuator is less impacted by gravity with no special mounting orientation requirements.

### VARIOUS APPLICATIONS

Application includes battery switch and standby equipment, DC power control, circuit protection, etc.

### OPTIONAL AUXILIARY CONTACT

Allows for contact position signal.

(COMPLY WITH EU ROHS DIRECTIVE (2011/65/EU



UL FILE NUMBER: E501749

## Nomenclature

Example

ALEV100

— B

A

Series code:

"ALEV100" = ALEV100 Series

Coil Voltage Code:

"B" = 12 VDC

"C" = 24 VDC

"E" = 48 VDC

Options (applied in this order):

Blank = Std. Options (Bottom Mount, Without Aux. Contact & Polarized Load Terminals)

"A" = With Aux. Contact (SPST-NO)

"S" = Side Mount Version

"N" = Non-Polar Load Terminals

# ALEV100 Series DC Contactor Specification

## Performance Data

MAIN CONTACT		LIFE	
Contact Arrangement	1 Form X (SPST-NO, DM)	Electrical Life	See table below
Rated Operating Voltage	12-750VDC	Mechanical Life	200,000 Cycles
Continuous Current	100A <sup>1</sup>		
Short Time Overcurrent	200A (3 minutes) <sup>2</sup>	AUX. CONTACT	
Maximum Short Circuit Current	1,250A (1/2 cycle, 60Hz)	Aux. Contact Arrangement	1 Form A
Dielectric Withstand Voltage	Between Contacts: 2500VDC, ≤1mA Contact to Coil: 2,200Vrms, ≤1mA	Max. Contact Rating	2A@30VDC/ 3A@125VAC
Insulation Resistance	Terminal to Terminal /Terminal to Coil New: Min 100 MΩ@500Vdc End of Life: 50 MΩ@500Vdc	Min. Contact Rating	100mA@8V
		Max. Contact Resistance	0.417ohms@30VDC/ 0.150ohms@125VAC
Voltage Drop (@100A)	≤80mV		
ENVIRONMENTAL DATA		OPERATE / RELEASE TIME	
Shock, 11ms ½ Sine, Operating	20G Peak	Close (includes bounce)	25ms, Max.
Vibration, Sine, Peak, 20G	80–2,000Hz	Release	10ms, Max.
Operating Temperature	-40 to +85°C		
Weight	0.42 lb (0.19 kg)		
COIL DATA			
Voltage Rating	12Vdc	24Vdc	48Vdc
Voltage (Max.)	16Vdc	28Vdc	52Vdc
Pick-up Voltage (20 °C)	8Vdc	16Vdc	33Vdc
Drop-out Voltage (20 °C)	1.2Vdc	2.4Vdc	4.8Vdc
Coil Current (20°C, Nominal Voltage)	461mA	250mA	122mA
Coil wattage (20°C, voltage rating, nominal)	5.5W	6.0W	6.0W
Max Pick-up Voltage (85°C)	9.6Vdc	19.2Vdc	38.4Vdc
Rated Coil Resistance±5% (20°C)	26 Ω	96 Ω	392 Ω

### Note:

1. Current is relevant to the cross-sectional area of conductor.
2. Ambient temperature: +40°C, 3 minutes

# ALEV100 Series DC Contactor Specification

## Polarized Load

Voltage (VDC)	650	450
Current(A)	100	100
Electrical Life (cycles)	2,000	10,000

## Non-Polarized Load

Voltage (VDC)	650	450
Current(A)	100	100
Electrical Life (cycles)	1,000	10,000

## Outline Dimensions : inches (mm)

### A. Bottom mount:

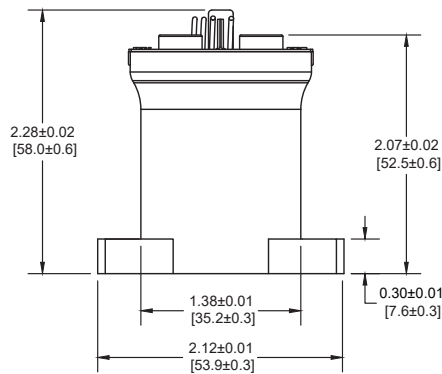
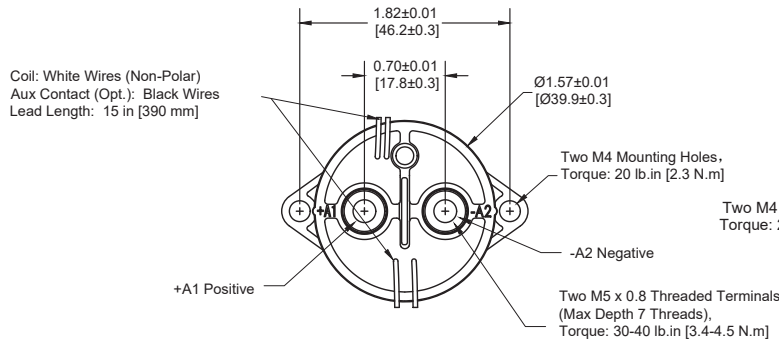

### B. Side mount:

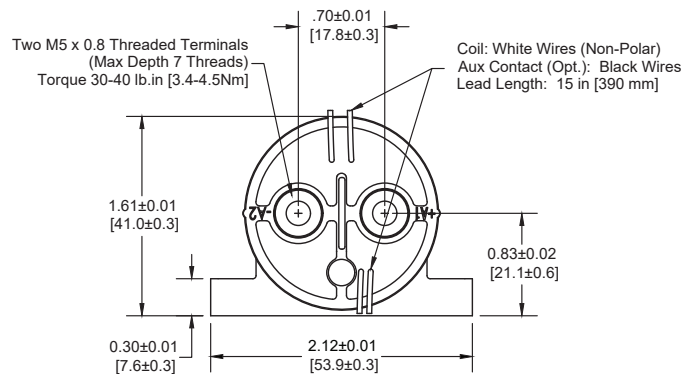
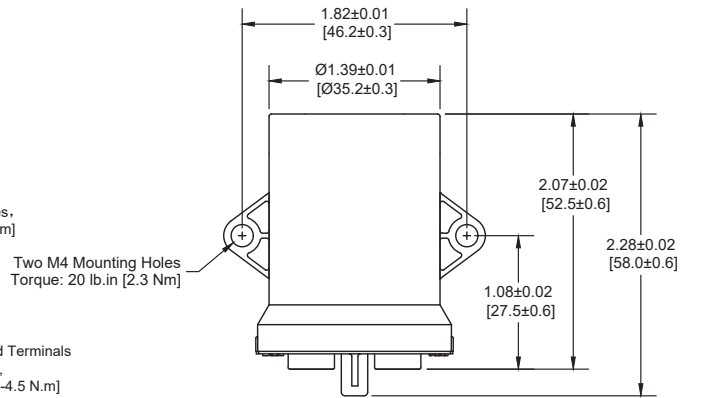

### Note:

1. The polarity of the product has the polarity of "+A1" and "-A2" on the outer cover, and the non-polar product has no polarity mark.

# ALEV100 Series DC Contactor Specification

## Application Note:

1. Be sure to use washer to prevent screws from loosening, all the terminals or copper bar must be in direct contact with the contactor's terminals. Screw tightening torque is specified below. Exceeding the maximum torque can lead to product failure.
  - Contact torque: 30 - 40 lb.in (3.4 - 4.5 N.m) Max. Active length of thread is 7.0 mm
  - Mounting torque: 20 lb.in (2.3 N.m)
2. Contact terminals are polarized so refer to drawing during connecting. We suggest using a varistor rather than diode as a surge protector.
3. Do not use if dropped.
4. Avoid installing in a strong magnetic field (close to a transformer or magnet), or near a heat source.
5. Electrical life  
Use per load capability and life cycle limits so as not to cause a function failure (treat the contactor as a product with specified life and replace it when necessary). It is possible to make parts burn around the contactor once operating failure occurs. It is necessary to take layout into account and to make sure power shall be cut off within 1 second.
6. Lifetime of internal gas diffusion  
The contactor is sealed and filled with gas, lifetime of gas diffusion is determined by temperature in contact chamber (ambient temperature + temperature generated by contact operation). Operate only in an ambient temperature from -40 to +85 °C.
7. Drive power must be greater than coil power or it will reduce performance capability.
8. Avoid debris or oil contamination on the main terminals to optimize contact and avoid excess heat generation.