

April 1995

## 12A, 600V Current Sensing N-Channel IGBT

### Features

- 12A, 600V
- $r_{DS(ON)}$  ..... 0.27 $\Omega$
- Low  $V_{CE(SAT)}$  at 25A ..... 2.5V (Typ)
- Ultra-Fast Turn-On ..... 100ns (Typ)
- Polysilicon MOS Gate - Voltage Controlled Turn On/Off
- High Current Handling at +100°C ..... 10A
- Current Sensing Pilot

### Description

The HGTB12N60D1C Insulated-Gate Bipolar Transistor is a MOS-gate turn on/off power switching device combining the best advantages of power MOSFETs and bipolar transistors, and current sensing pilots. The result is a device that has the high input impedance of MOSFETs and the low on-state conduction losses similar to bipolar transistors. The device design and gate characteristics of the IGBT are also similar to power MOSFETs. An important difference is the equivalent  $r_{DS(ON)}$  drain resistance which is modulated to a low value (ten times lower) when the gate is turned on. The much lower on-state voltage drop also varies only moderately between +25°C and +150°C, offering extended power handling capability.

The IGBT is ideal for many high-voltage switching applications operating at low frequencies and where low conduction losses are essential, such as AC and DC motor controls, power supplies and drivers for solenoids, relays and contactors.

#### PACKAGING AVAILABILITY

| PART NUMBER  | PACKAGE  | BRAND    |
|--------------|----------|----------|
| HGTB12N60D1C | TS-001AA | 12N60D1C |

NOTE: When ordering, use the entire part number.

### Package

JEDEC TS-001AA (5 LEAD TO-220)

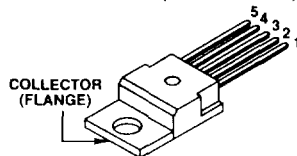

- 1 - GATE
- 2 - SENSE
- 3 - COLLECTOR
- 4 - (KELVIN) EMITTER
- 5 - EMITTER

### Terminal Diagram

N-CHANNEL ENHANCEMENT MODE

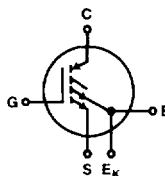

### Absolute Maximum Ratings $T_C = +25^\circ\text{C}$ , Unless Otherwise Specified

|   | HGTB12N60D1C | UNITS |
|---|--------------|-------|
| Collector-Emitter Voltage ( $V_{GE} = 0\text{V}$ )                    | 600          | V     |
| Collector-Gate Voltage ( $R_{GE} = 1\text{M}\Omega$ )                 | 600          | V     |
| Collector Current Continuous at $T_C = +100^\circ\text{C}$            | 12           | A     |
| at $T_C = +25^\circ\text{C}$  | 18           | A     |
| Collector Current Pulsed (Note 1)                                     | 40           | A     |
| Gate-Emitter Voltage  | $\pm 25$     | V     |
| Power Dissipation Total at $T_C = +25^\circ\text{C}$                  | 75           | W     |
| Power Dissipation Derating $T_C > +25^\circ\text{C}$                  | 0.6          | W/°C  |
| Operating and Storage Junction Temperature Range                      | -55 to +150  | °C    |
| Thermal Resistance, Junction to Case                                  | 1.67         | °C/W  |
| Maximum Lead Temperature for Soldering<br>(1/8 inch from case for 5s) | 260          | °C    |

NOTE: 1. Repetitive Rating. Pulse width limited by maximum junction temperature. Gate control turn-off not allowed above 50A.

#### HARRIS SEMICONDUCTOR IGBT PRODUCT IS COVERED BY ONE OR MORE OF THE FOLLOWING U.S. PATENTS:

|           |           |           |           |           |           |           |           |
|-----------|-----------|-----------|-----------|-----------|-----------|-----------|-----------|
| 4,364,073 | 4,417,385 | 4,430,792 | 4,443,931 | 4,466,176 | 4,516,143 | 4,532,534 | 4,567,641 |
| 4,587,713 | 4,598,461 | 4,605,948 | 4,618,872 | 4,620,211 | 4,631,564 | 4,639,754 | 4,639,762 |
| 4,641,162 | 4,644,637 | 4,682,195 | 4,684,413 | 4,694,313 | 4,717,679 | 4,743,952 | 4,783,690 |
| 4,794,432 | 4,801,986 | 4,803,533 | 4,809,045 | 4,809,047 | 4,810,665 | 4,823,176 | 4,837,606 |
| 4,860,080 | 4,883,767 | 4,888,627 | 4,890,143 | 4,901,127 | 4,904,609 | 4,933,740 | 4,963,951 |
| 4,969,027 |           |           |           |           |           |           |           |

## Specifications HGTB12N60D1C

### Electrical Specifications $T_C = +25^\circ\text{C}$ , Unless Otherwise Specified

| PARAMETERS  | SYMBOL        | TEST CONDITIONS  | LIMITS                     |      |           | UNITS         |   |
|---|---------------|--|----------------------------|------|-----------|---------------|---|
|   |               |  | MIN                        | TYP  | MAX       |               |   |
| <b>OFF CHARACTERISTICS</b>                                      |               |  |                            |      |           |               |   |
| Collector-Emitter Breakdown Voltage                             | $V_{CES}$     | $I_C = 25\mu\text{A}$ , $V_{GE} = 0\text{V}$   | 600                        | -    | -         | V             |   |
| Collector Cut-Off Current                                       | $I_{CES}$     | $T_C = +25^\circ\text{C}$ , $V_{GE} = 0\text{V}$ ,<br>$V_{CE} = \text{Maximum Rating}$   | -                          | -    | 250       | $\mu\text{A}$ |   |
|   |               | $T_C = +150^\circ\text{C}$ , $V_{GE} = 0\text{V}$ ,<br>$V_{CE} = \text{Maximum Rating} \times 0.8$ (Note 1)  | -                          | -    | 4         | mA            |   |
| Gate-Emitter Leakage Current                                    | $I_{GES}$     | $V_{GE} = \pm 20\text{V}$  | -                          | -    | $\pm 500$ | nA            |   |
| <b>ON CHARACTERISTICS (Note 2)</b>                              |               |  |                            |      |           |               |   |
| Gate Threshold Voltage  | $V_{GE(TH)}$  | $V_{CE} = V_{GE}$ ,<br>$I_C = 250\mu\text{A}$  | $T_C = +25^\circ\text{C}$  | 2    | 4         | 5             | V |
|   |               |  | $T_C = +150^\circ\text{C}$ | -    | 2.5       | -             | V |
| Collector-Emitter Saturation Voltage                            | $V_{CE(SAT)}$ | $V_{GE} = 15\text{V}$ , $I_C = 10\text{A}$ , $T_C = +25^\circ\text{C}$   | -                          | 2.5  | 2.7       | V             |   |
|   |               | $V_{GE} = 15\text{V}$ , $I_C = 10\text{A}$ , $T_C = +150^\circ\text{C}$  | -                          | 2.8  | -         | V             |   |
|   |               | $V_{GE} = 10\text{V}$ , $I_C = 10\text{A}$ , $T_C = +25^\circ\text{C}$   | -                          | 2.9  | -         | V             |   |
| <b>DYNAMIC CHARACTERISTICS</b>                                  |               |  |                            |      |           |               |   |
| Input Capacitance   | $C_{IES}$     | $V_{GE} = 0\text{V}$ , $V_{CE} = 25\text{V}$ , $f = 1\text{MHz}$   | -                          | 1050 | -         | pF            |   |
| Output Capacitance  | $C_{OES}$     |  | -                          | 340  | -         | pF            |   |
| Reverse Transfer Capacitance                                    | $C_{RES}$     |  | -                          | 10   | -         | pF            |   |
| <b>SWITCHING CHARACTERISTICS (See Figures 8 and 9) (Note 2)</b> |               |  |                            |      |           |               |   |
| Turn-On Delay Time  | $t_{D(ON)}$   | Resistive Load, $T_J = +125^\circ\text{C}$ ,<br>$I_C = 10\text{A}$ , $V_{CE} = 500\text{V}$ , $V_{GE} = 15\text{V}$ ,<br>$R_{G(ON)} = 50\Omega$ , $R_{G(OFF)} = 100\Omega$                                 | -                          | 100  | -         | ns            |   |
| Rise Time   | $t_R$         |  | -                          | 100  | -         | ns            |   |
| Turn-Off Delay Time   | $t_{D(OFF)}$  |  | -                          | 0.4  | -         | $\mu\text{s}$ |   |
| Fall Time   | $t_F$         |  | -                          | 2.5  | -         | $\mu\text{s}$ |   |
| Turn-Off Delay Time   | $t_{D(OFF)I}$ | Inductive Load, $T_J = +125^\circ\text{C}$ ,<br>$L = 45\mu\text{H}$ , $I_C = 10\text{A}$ , $V_{CE(CLAMP)} = 500\text{V}$ ,<br>$V_{GE} = 15\text{V}$ , $R_{G(ON)} = 50\Omega$ ,<br>$R_{G(OFF)} = 100\Omega$ | -                          | 0.8  | 1.2       | $\mu\text{s}$ |   |
| Fall Time   | $t_{FI}$      |  | -                          | 0.8  | 1.0       | $\mu\text{s}$ |   |
| Equivalent Fall Time  | $t_{F(EQ)}$   |  | -                          | 0.6  | 0.8       | $\mu\text{s}$ |   |
| Turn-Off Switching Losses                                       | $W_{OFF}$     |  | -                          | 1.6  | 2.0       | mJ            |   |
| <b>PILOT CHARACTERISTICS (Notes 2, 3 and 4)</b>                 |               |  |                            |      |           |               |   |
| Pilot-Emitter Kelvin Voltage                                    | $V_{PEK}$     | $V_{GE} = 15V_{DC}$ , $R_P = 2k\Omega$   | -                          | 1.25 | -         | V             |   |
|   |               |  | $I_C = 5\text{A}$          | -    | 1.25      | -             | V |
|   |               |  | $I_C = 10\text{A}$         | 1.4  | 1.67      | 1.8           | V |
| $I_C = 20\text{A}$  | -             | 2.06   | -                          | V    |           |               |   |

**NOTES:**

1. Applies for  $3.3^\circ\text{C}$  per watt maximum thermal resistance, case-to-ambient.
2. Pulse test: Pulse widths  $\leq 300\mu\text{s}$ , duty cycle  $\leq 2\%$ .
3. Refer to Figure 10.
4. When not in use connect S to emitter.

3

IGBTs

Typical Performance Curves

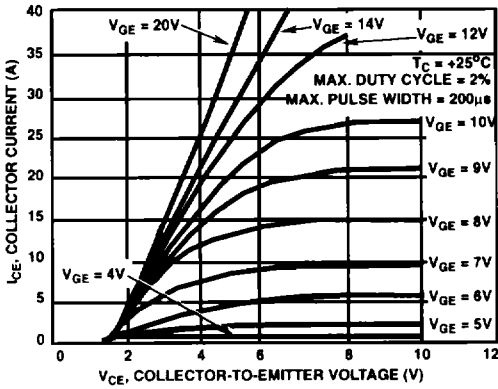

FIGURE 1. TYPICAL OUTPUT CHARACTERISTICS

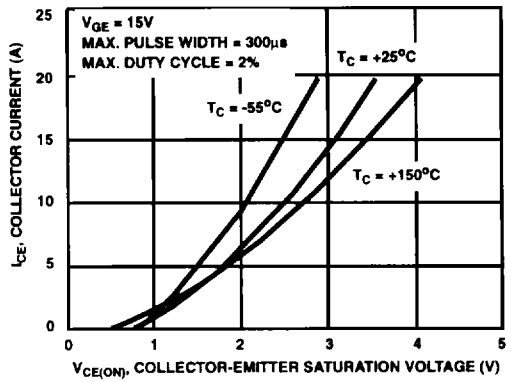

FIGURE 2. TYPICAL COLLECTOR-EMITTER SATURATION VOLTAGE

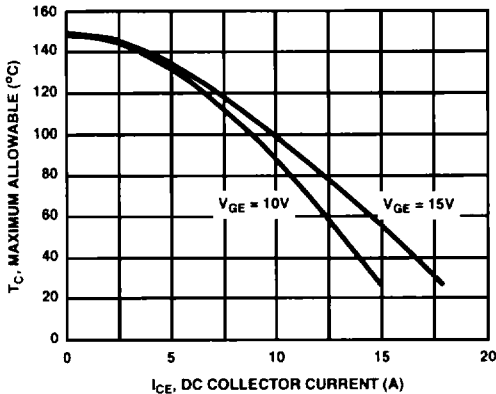

FIGURE 3. MAXIMUM ALLOWABLE CASE TEMPERATURE vs. DC COLLECTOR CURRENT

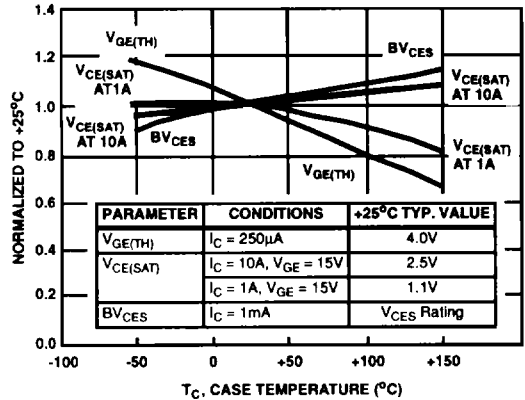

FIGURE 4. TYPICAL TEMPERATURE DEPENDENCE OF PARAMETERS

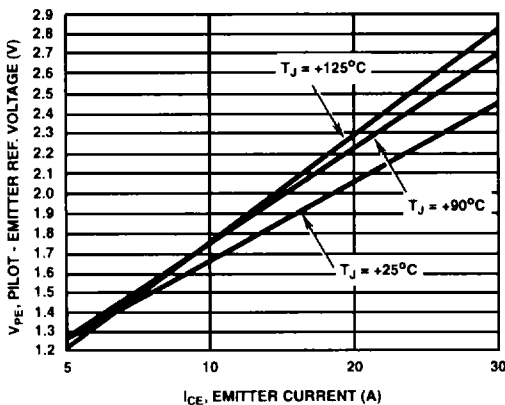

FIGURE 5. TYPICAL EMITTER PILOT CHARACTERISTICS 2kΩ PILOT RESISTOR

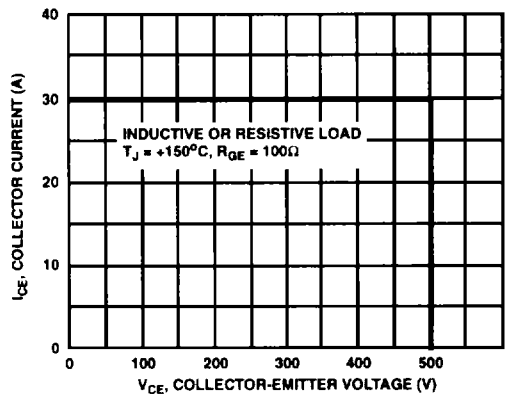

FIGURE 6. TURN-OFF SAFE OPERATING AREA

Typical Performance Curves (Continued)

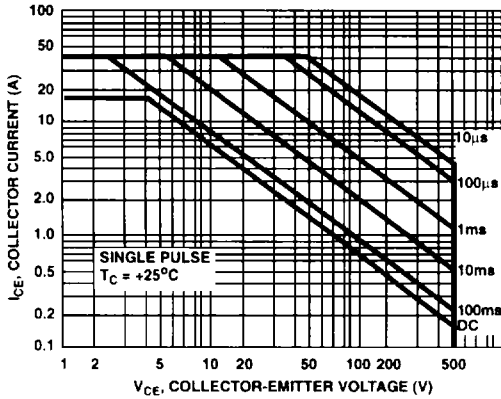

FIGURE 7. TURN-ON SAFE OPERATING AREA

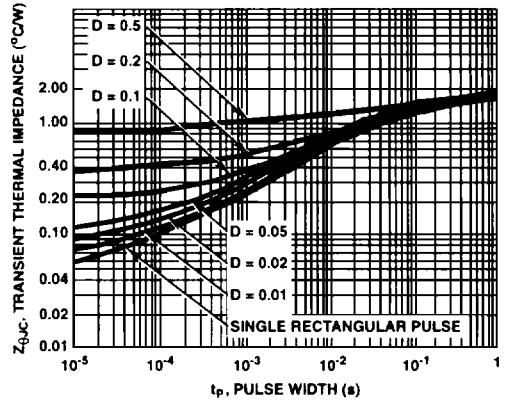
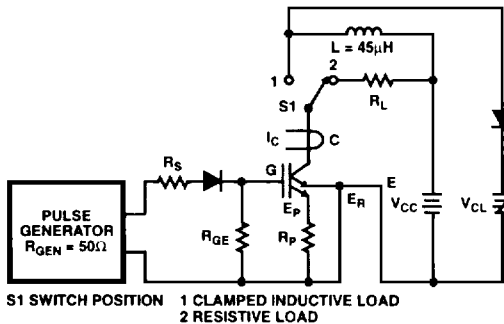

FIGURE 8. MAXIMUM TRANSIENT THERMAL IMPEDANCE

Test Circuits and Waveforms



S1 SWITCH POSITION 1 CLAMPED INDUCTIVE LOAD  
2 RESISTIVE LOAD

$$R_{G(ON)} = \frac{(R_{GEN} + R_S)(R_{GE})}{R_{GEN} + R_S + R_{GE}}$$

L-I<sub>C</sub> MAXIMUM PULSE WIDTH

FIGURE 9. BASIC SWITCHING TEST CIRCUIT

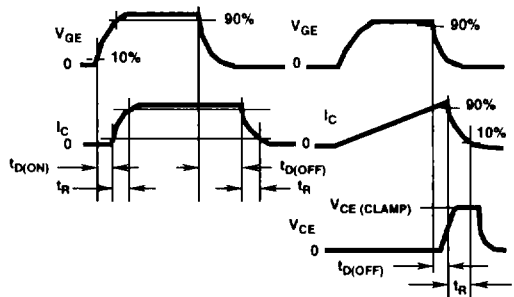

RESISTIVE LOAD

INDUCTIVE LOAD

(WAVEFORMS NOT TO SCALE)

FIGURE 10. SWITCHING WAVEFORMS

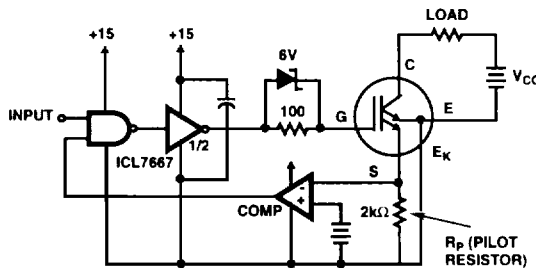

FIGURE 11. TYPICAL CIRCUIT UTILIZING THE EMITTER PILOT FOR OVERCURRENT PROTECTION