

Telephone Tone Ringer Bipolar Linear/I²L

Features

- Complete Telephone Bell Replacement Circuit with Minimum External Components
- On-Chip Diode Bridge and Transient Protection
- Direct Drive for Piezoelectric Transducers
- Push Pull Output Stage for Greater Output Power Capability
- Base Frequency Options
 - 34017A-1: 1.0 kHz
 - 34017A-2: 2.0 kHz
 - 34017A-3: 500 Hz
- Input Impedance Signature Meets Bell and EIA Standards
- Rejects Rotary Dial Transient

34017A

**TELEPHONE TONE RINGER
BIPOLAR LINEAR/I²L**

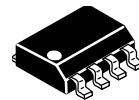

D SUFFIX
98A42564B
8-LEAD SOIC

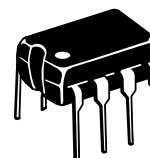

P SUFFIX
98A42420B
8-LEAD DIP

ORDERING INFORMATION

Device	Temperature Range (T _A)	Package
MC34017AD/DR2	-20°C to 60°C	8 SOIC
MC34017AP		8 Plastic DIP

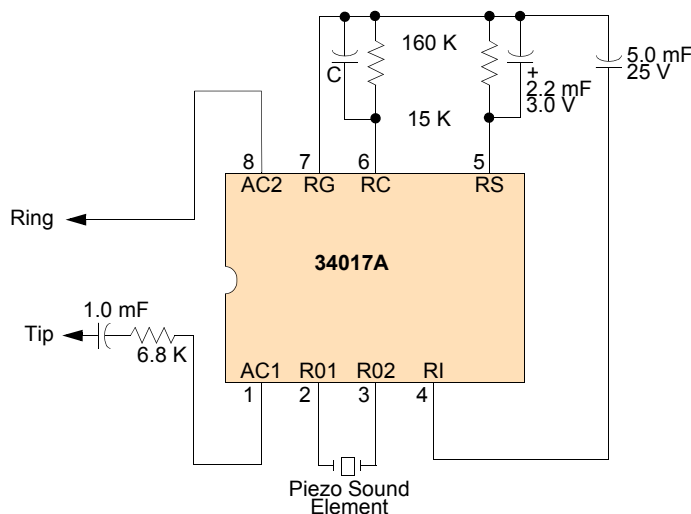

34017A-1: C=1000 pF
34017A-2: C=500 pF
34017A-3: C=2000 pF

This device contains 97 active transistors and 79 gates

Figure 1. 34017A Simplified Application Diagram

INTERNAL BLOCK DIAGRAM

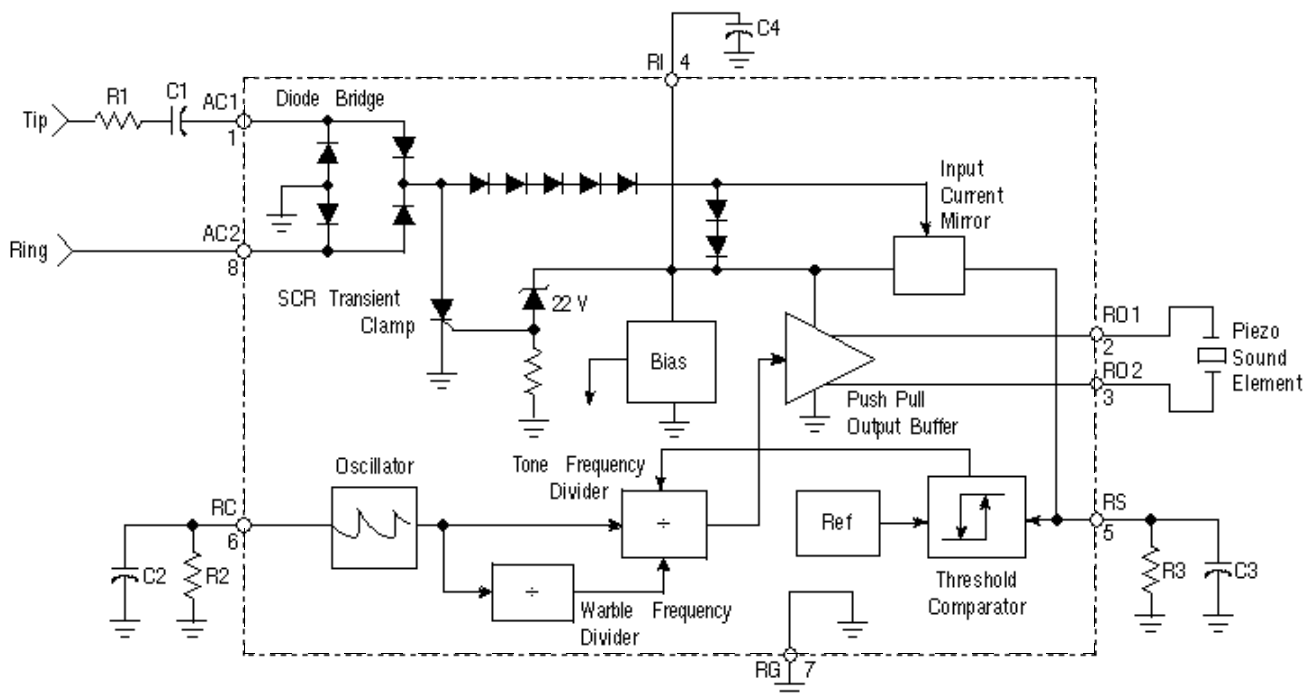

Figure 2. 34017A Simplified Internal Block Diagram

TERMINAL CONNECTIONS

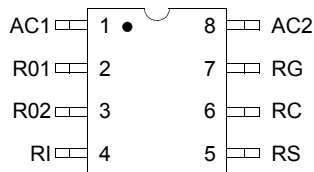

Figure 3. 34017A Terminal Connections

Table 1. 34017A Terminal Definitions

Terminal Number	Terminal Name	Terminal Function	Formal Name	Definition
1, 8	AC1, AC2			The input terminals to the full-wave diode bridge. The AC ringing signal from the telephone line energizes the ringer through this bridge.
5	RS			The input of the threshold comparator to which diode bridge current is mirrored and sensed through an external resistor (R3). Nominal threshold is 1.2 V. This Terminal internally clamps at 1.5 V.
4	RI			The positive supply terminal for the oscillator, frequency divider, and output buffer circuits.
2, 3	RO1, RO2			The tone ringer output terminals through which the sound element is driven.
7	RG			The negative terminal of the diode bridge and the negative supply terminal of the tone generating circuitry.
6	RC			The oscillator terminal for the external resistor and capacitor which control the tone ringer frequencies (R2, C2).

MAXIMUM RATINGS

Table 2. Maximum Ratings

All voltages are with respect to RG, Terminal 7, unless otherwise noted. ESD voltage data is available upon request.

Rating	Symbol	Value	Unit
Operating AC Input Current (Terminals 1, 8)	–	20	mA, RMS
Transient Input Current (Terminals 1, 8) (T < 2.0 ms)	V_{IN}	±300	mA, peak
Voltage Applied at RC (Terminal 6)	V_{RC}	5.0	V
Voltage Applied at RS (Terminal 5)	V_{RS}	5.0	V
Voltage Applied to Outputs (Terminals 2, 3)	V_O	-2.0 to V_{RI}	V
Power Dissipation (@ 25°C)	P_D	1.0	W
Operating Ambient Temperature	T_A	-20 to 60	°C
Storage Temperature	T_{STG}	-65 to 150	°C

STATIC ELECTRICAL CHARACTERISTICS

Table 3. Static Electrical Characteristics

 Typical values noted reflect the approximate parameter mean at $T_A = 25^\circ\text{C}$ under nominal conditions unless otherwise noted.

Characteristic	Symbol	Min	Typ	Max	Unit
Ringing Start Voltage $V_{\text{START}} = V_I$ at Ring Start $V_I > 0$ (Test 1a) $V_I < 0$ (Test 1b)	$V_{\text{START}} (+)$ $V_{\text{START}} (-)$	34 -34	37.5 -37.5	41 -41	V_{DC}
Ringing Stop Voltage (Test 1c) $V_{\text{STOP}} = V_I$ at Ring Stop 34017A-1 34017A-2 34017A-3	V_{STOP}	14 12 14	16 14 16	22 20 22	V_{DC}
Output Frequencies ($V_I = 50\text{ V}$) (Test 1d) 34017A-1 High Tone Low Tone Warble Tone 34017A-2 High Tone Low Tone Warble Tone 34017A-3 High Tone Low Tone Warble Tone	f_H f_L f_W f_H f_L f_W f_H f_L f_W	937 752 11.5 1874 1504 11.5 937 752 23	1010 808 12.5 2020 1616 12.5 1010 808 25	1083 868 14 2166 1736 14 1083 868 28	Hz
Output Voltage ($V_I = 50\text{ V}$) (Test 6)	V_O	34	37	43	V_{PP}
Output Short – Circuit Current (Test 2)	$I_{\text{RO1}}, I_{\text{RO2}}$	35	60	80	m_{APP}
Input Diode Voltage ($I_I = 5.0\text{ mA}$) (Test 3)	V_D	5.4	6.2	6.8	V_{DC}
Input Voltage – SCR OFF ($I_I = 30\text{ mA}$) (Test 4a)	V_{OFF}	30	38	43	V_{DC}
Input Voltage – SCR ON ($I_I = 100\text{ mA}$) (Test 4b)	V_{ON}	3.2	4.1	6.0	V_{DC}
RS Clamp Voltage ($V_I = 50\text{ V}$) (Test 5)	V_{CLAMP}	1.3	1.5	1.8	V_{DC}

APPLICATION CIRCUIT PERFORMANCE

Refer to Typical Application.

Characteristic	Typ	Unit
Output Tone Frequencies		Hz
34017A-1	808/1010	
34017A-2	1616/2020	
34017A-3	404/505	
Warble Frequencies	12.5	
Output Voltage ($V_I \geq 60 V_{RMS}$, 20 Hz)	37	V_{PP}
Output Duty Cycle	50	%
Ringing Start Input Voltage (20 Hz)	36	V_{RMS}
Ringing Stop Input Voltage (20 Hz)	21	V_{RMS}
Maximum AC Input Voltage (≤ 68 Hz)	150	V_{RMS}
Impedance When Ringing		$k\Omega$
$V_I = 40 V_{RMS}$, 15 Hz	>16	
$V_I = 130 V_{RMS}$, 23 Hz	12	
Impedance When Not Ringing		
$V_I = 10 V_{RMS}$, 24 Hz	28	$k\Omega$
$V_I = 2.5 V_{RMS}$, 24 Hz	> 1.0	$M\Omega$
$V_I = 10 V_{RMS}$, 5.0 Hz	55	$k\Omega$
$V_I = 3.0 V_{RMS}$, 200 to 3200 Hz	> 200	$k\Omega$
Maximum Transient Input Voltage ($T \leq 2.0$ ms)	1500	V
Ringer Equivalence		
Class A	0.5	–
Class B	0.9	–

TYPICAL APPLICATIONS

INTRODUCTION

The 34017A Tone Ringer derives its power supply by rectifying the AC ringing signal. It uses this power to activate a tone generator and drive a piezo-ceramic transducer. The tone generation circuitry includes a relaxation oscillator and frequency dividers which produce high and low frequency tones as well as the tone warble frequency. The relaxation oscillator frequency f_O is set by resistor R2 and capacitor C2 connected to Terminal RC. The oscillator will operate with f_O from 1.0 kHz to 10 kHz with the proper choice of external components (see Figure 2).

The frequency of the tone ringer output signal at RO1 and RO2 alternates between $f_O/4$ to $f_O/5$. The warble rate at which the frequency changes is $f_O/320$ for the 34017A-1, $f_O/640$ for the 34017A-2 and $f_O/160$ for the 34017A-3. With a 4.0 kHz oscillator frequency, the 34017A-1 produces 800 Hz and 1000 Hz tones with a 12.5 Hz warble rate. The 34017A-2 generates 1600 Hz and 2000 Hz tones with a similar 12.5 Hz warble frequency from an 8.0 kHz oscillator frequency. The 34017A-3 will produce 400 Hz and 500 Hz tones with a 12.5 Hz warble rate from a 2.0 kHz oscillator frequency. The tone ringer output circuit can source or sink 20 mA with an output voltage swing of 37 V peak-to-peak. Volume control is readily implemented by adding a variable resistance in series with the piezo transducer.

Input signal detection circuitry activates the tone ringer output when the AC line voltage exceeds programmed threshold level. Resistor R3 determines the ringing signal amplitude at which an output signal at RO1 and RO2 will be generated. The AC ringing signal is rectified by the internal diode bridge. The rectified input signal produces a voltage across R3 which is referenced to RG. The voltage across resistor R3 is filtered by capacitor C3 at the input to the threshold circuit.

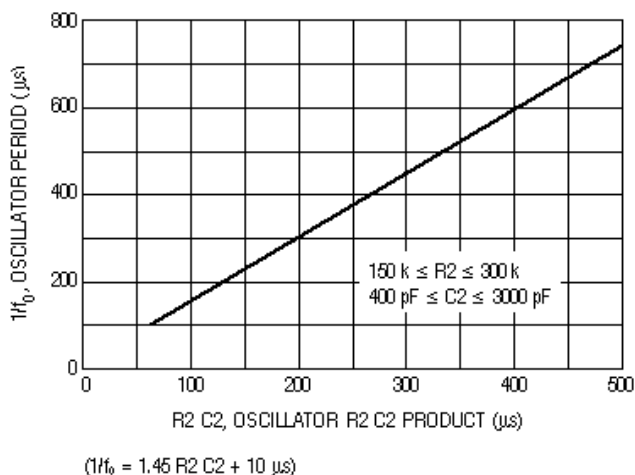

Figure 4. Oscillator Period ($1/f_O$) versus Oscillator R2 C2 Product

When the voltage on capacitor C3 exceeds 1.2 V, the threshold comparator enables the tone ringer output. Line transients produced by pulse dialing telephones do not charge capacitor C3 sufficiently to activate the tone ringer output.

Capacitors C1 and C4 and resistor R1 determine the 10 V, 24 Hz signature test impedance. C4 also provides filtering for the output stage power supply to prevent droop in the square wave output signal. Six diodes in series with the rectifying bridge provide the necessary non-linearity for the 2.5 V, 24 Hz signature tests.

An internal shunt voltage regulator between the RI and RG terminals provides DC voltage to power the output stage, oscillator, and frequency dividers. The DC voltage at RI is limited to approximately 22 V in regulation. To protect the IC from telephone line transients, an SCR is triggered when the regulator current exceeds 50 mA. The SCR diverts current from the shunt regulator and reduces the power dissipation within the IC.

External Components

R1	Line Input Register	R1 affects the tone ringer input impedance. It also influences ringing threshold voltage and limits current from line transients. Range: 2.0 to 10 k Ω .
C1	Line Input Capacitor	C1 AC couples the tone ringer to the telephone line and controls ringer input impedance at low frequencies. Range: 0.4 to 2.0 μ F.
R2	Oscillator Resistor	Range: 150 to 300 k Ω .
C2	Oscillator Capacitor	Range: 400 to 3000 pF.
R3	Input Current Sense Resistor	R3 controls the ringing threshold voltage. Increasing R3 decreases the ring-start voltage. Range: 5.0 to 18 k Ω .
C3	Ringing Threshold Filter Capacitor	C3 filters the AC voltage across R3 at the input of the ringing threshold comparator. It also provides dialer transient rejection. Range: 0.5 to 5.0 μ F.
C4	Ringer Supply Capacitor	C4 filters supply voltage for the tone generating circuits. It also provides an AC current path for the 10 V _{RMS} ringer signature impedance. (Range: 1.0 to 10 μ F).

This paragraph is boilerplate - you may add to it but, can not change wording. You may change numeric values

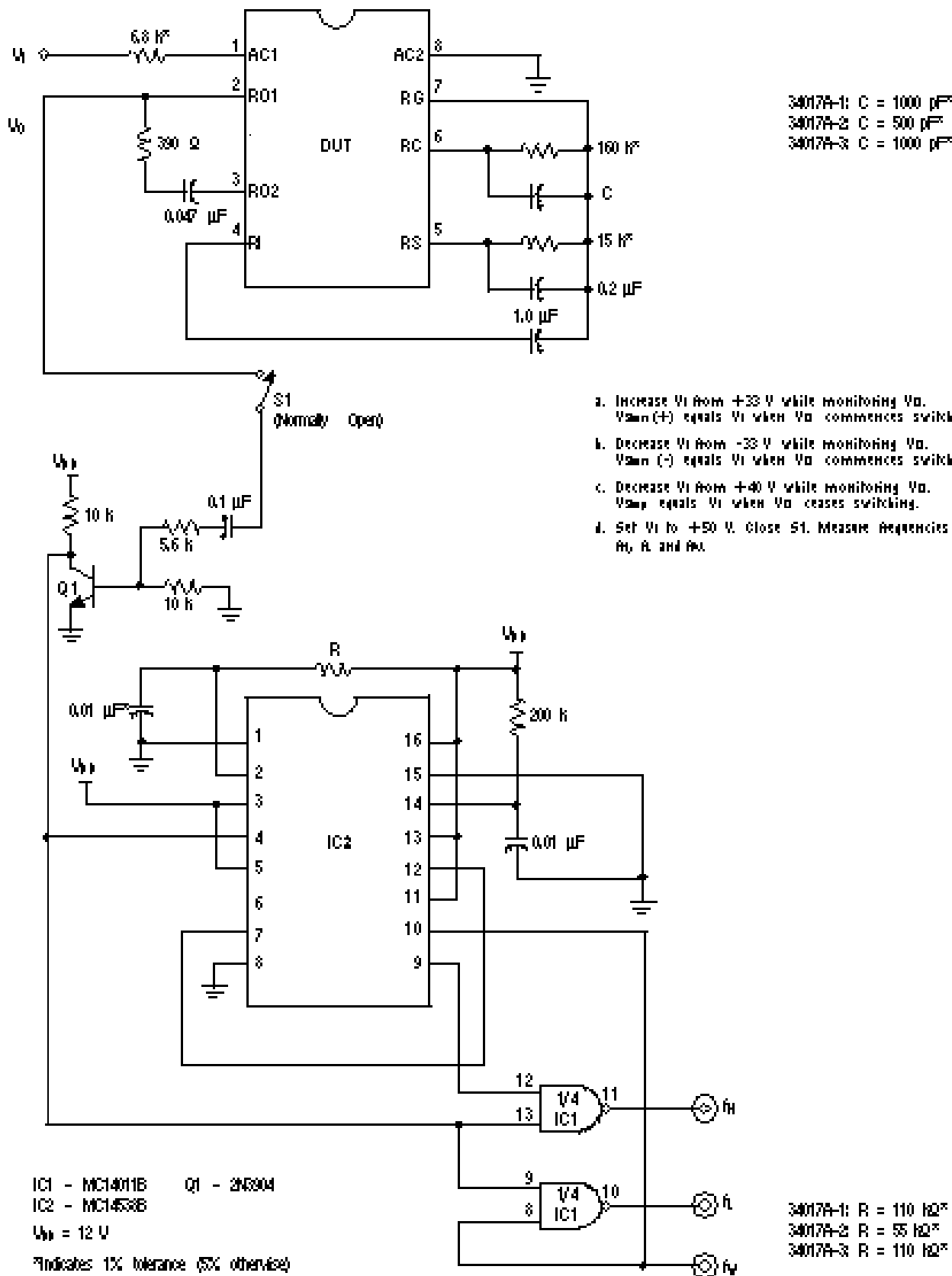
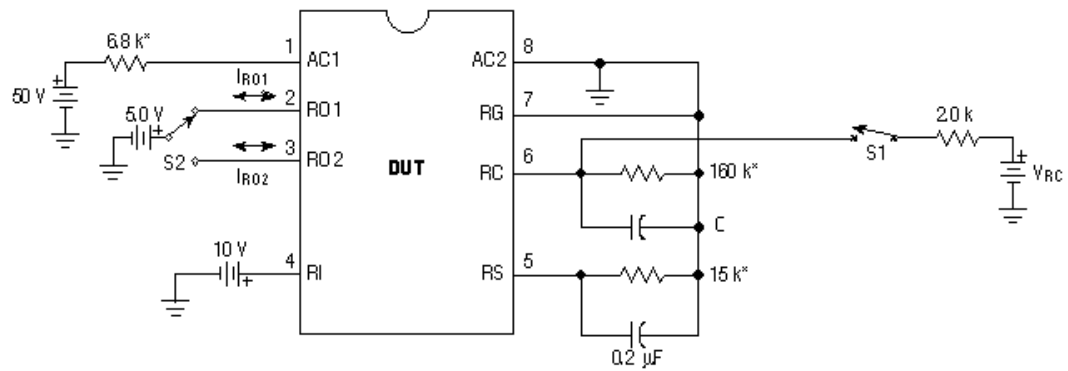

Figure 5. Test One



34017A-1: C = 1000 pF*

34017A-2: C = 500 pF*

34017A-3: C = 1000 pF*

*Indicates 1% tolerance (5% otherwise)

With $V_{RC} = 4.0\text{ V}$, close S1. Switch S2 to Pin 2 and measure current at Pin 2 (I_{O1}). Repeatedly switch V_{RC} between 4.0 V and 0 V until Pin 2 current changes polarity. Measure the opposite polarity current (I_{O2}).

Calculate: $I_{RO1} = |I_{O1}| + |I_{O2}|$.

Switch S2 to Pin 3 and repeat.

Calculate: $I_{RO2} = |I_{O1}| + |I_{O2}|$.

Figure 6. Test Two

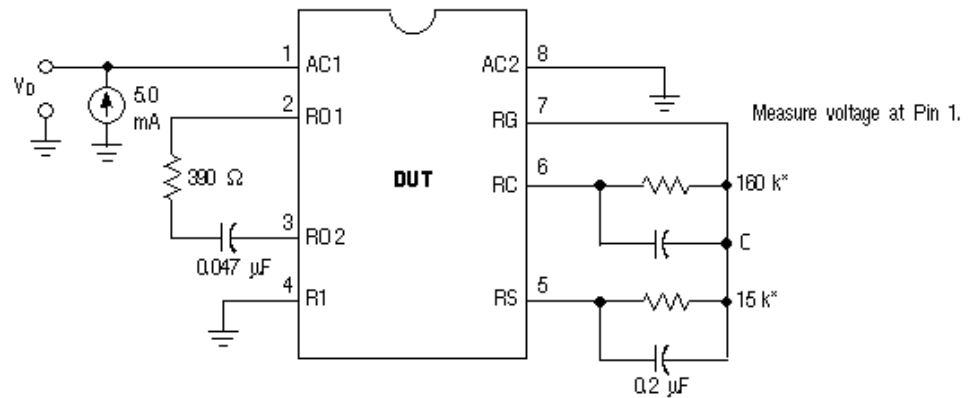

*Indicates 1% tolerance (5% otherwise)

34017A-1: C = 1000 pF*

34017A-2: C = 500 pF*

34017A-3: C = 1000 pF*

Figure 7. Test Three

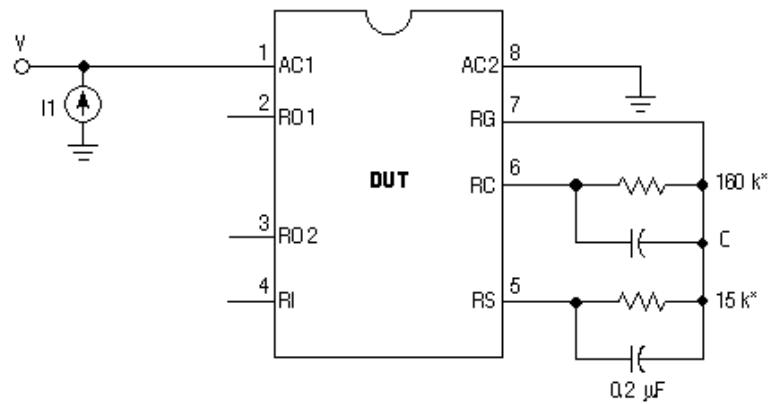

34017A-1: C = 1000 pF*

34017A-2: C = 500 pF*

34017A-3: C = 1000 pF*

*Indicates 1% tolerance (5% otherwise)

- Set I1 to 30 mA. Measure voltage at Pin 1 (V_{off}).
 - Set I1 to 100 mA. Measure voltage at Pin 1 (V_{on}).
- (Each test < 30 ms)

Figure 8. Test Four

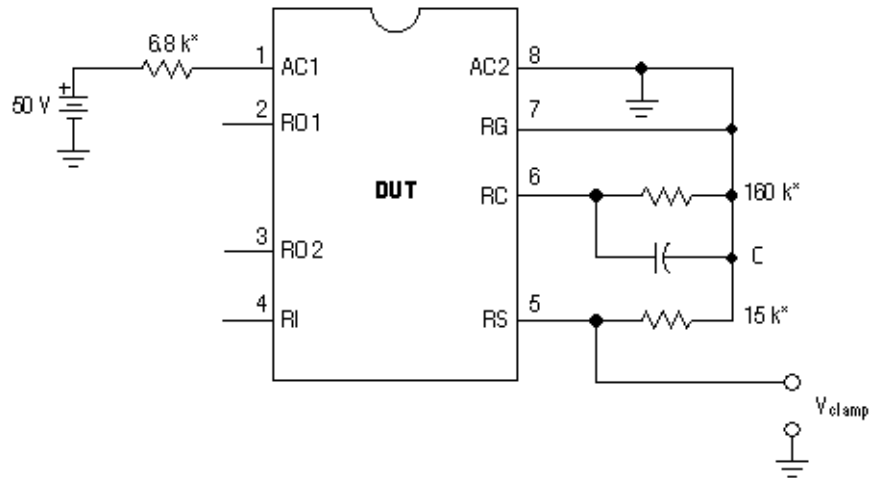

34017A-1: C = 1000 pF*

34017A-2: C = 500 pF*

34017A-3: C = 1000 pF*

*Indicates 1% tolerance (5% otherwise)

Measure voltage at Pin 5 (V_{clamp}).

Figure 9. Test Five

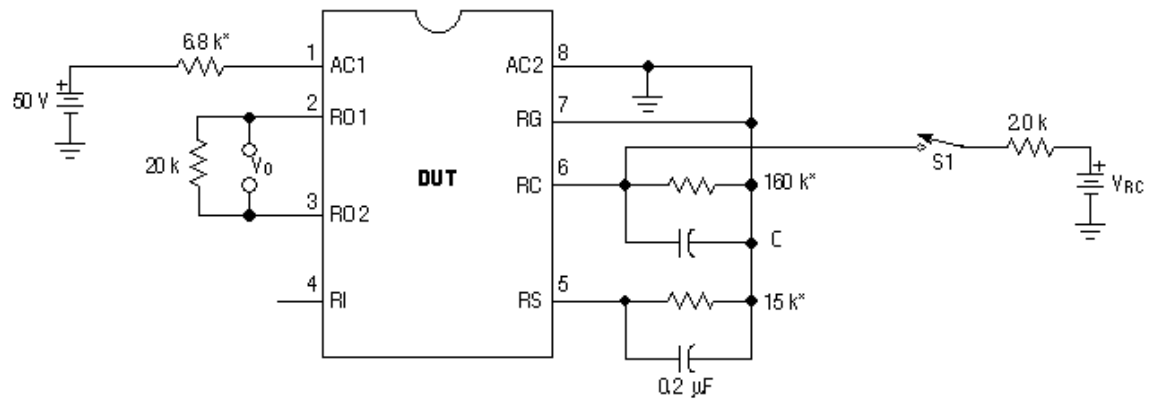

34017A-1: C = 1000 pF*

34017A-2: C = 500 pF*

34017A-3: C = 1000 pF*

*Indicates 1% tolerance (5% otherwise)

With $V_{RC} = 4.0\text{ V}$, close S1. Measure dc voltage between Pins 2 and 3 (V_{01}). Repeatedly switch V_{RC} between 4.0 V and 0 V until Pins 2 and 3 change state. Measure the new voltage between Pins 2 and 3 (V_{02}).

Calculate: $V_0 = |V_{01}| + |V_{02}|$.

Figure 10. Test Six

PACKAGING

PACKAGING DIMENSIONS

For the most current package revision, visit www.freescale.com and perform a keyword search using the 98A42420B listed below.

D SUFFIX
8-LEAD SOIC
98A42420B
ISSUE N

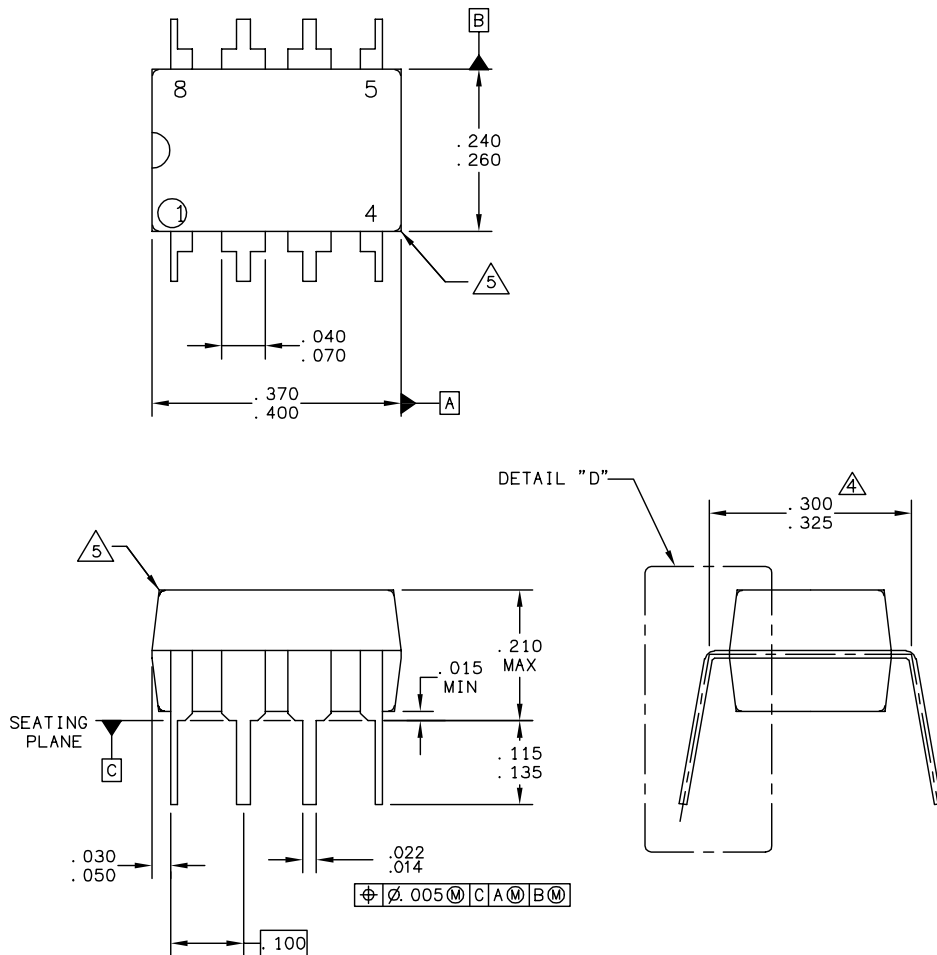

© FREESCALE SEMICONDUCTOR, INC. ALL RIGHTS RESERVED.	MECHANICAL OUTLINE	PRINT VERSION NOT TO SCALE	
TITLE: 8 LD PDIP	DOCUMENT NO: 98ASB42420B	REV: N	
	CASE NUMBER: 626-06	19 MAY 2005	
	STANDARD: NON-JEDEC		

D SUFFIX
8-LEAD SOIC
98A42420B
ISSUE N

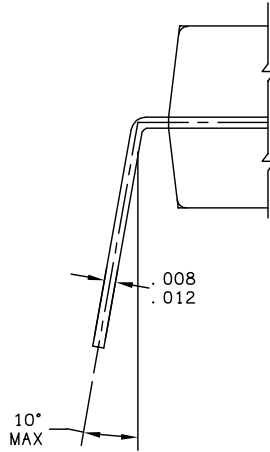

DETAIL "D"

© FREESCALE SEMICONDUCTOR, INC. ALL RIGHTS RESERVED.	MECHANICAL OUTLINE	PRINT VERSION NOT TO SCALE	
TITLE: 8 LD PDIP	DOCUMENT NO: 98ASB42420B	REV: N	
	CASE NUMBER: 626-06	19 MAY 2005	
	STANDARD: NON-JEDEC		

PACKAGING DIMENSIONS

For the most current package revision, visit www.freescale.com and perform a keyword search using the 98A42564B listed below.

D SUFFIX
8-LEAD SOIC
98A42564B
ISSUE U

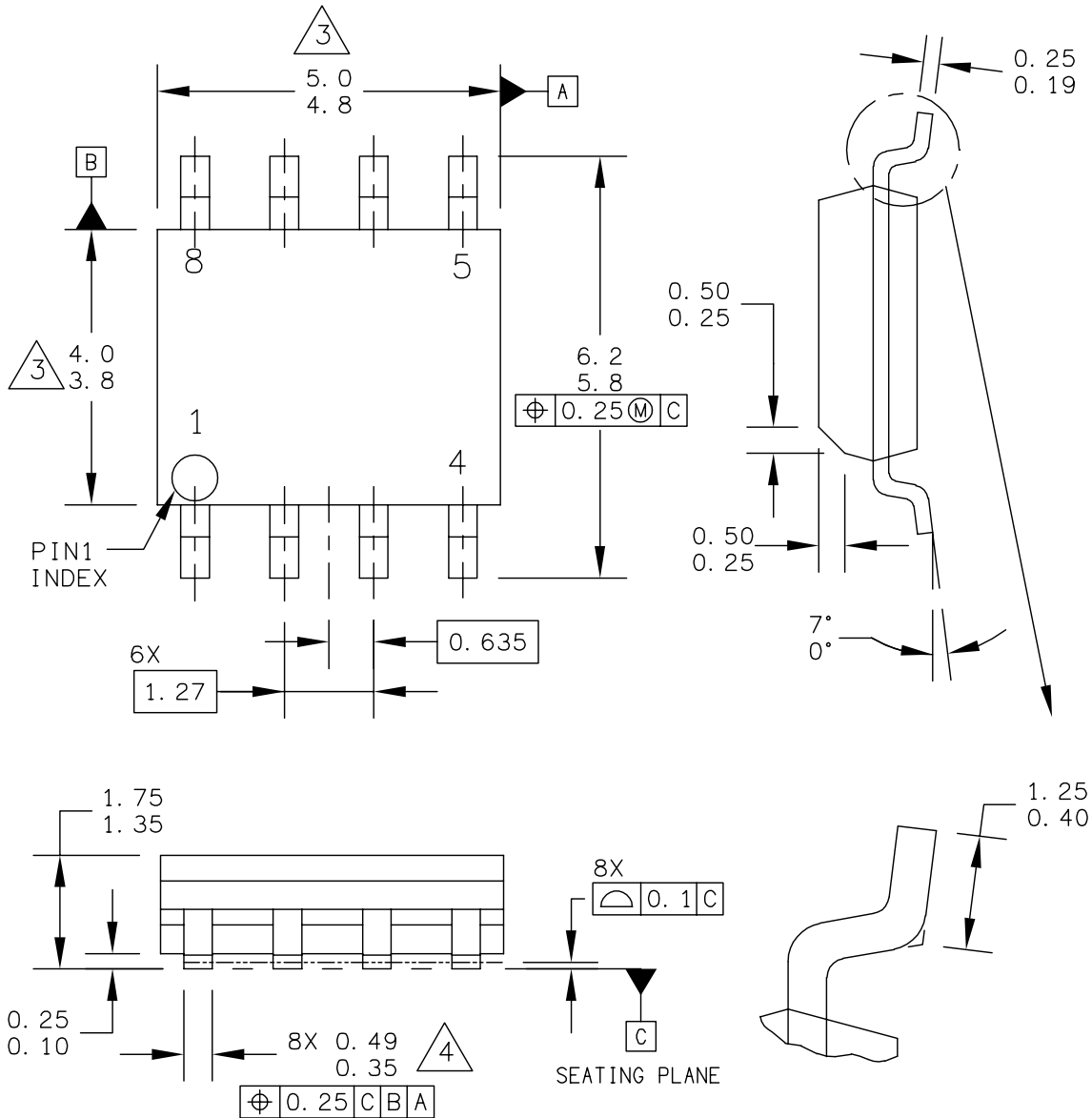

© FREESCALE SEMICONDUCTOR, INC. ALL RIGHTS RESERVED.	MECHANICAL OUTLINE	PRINT VERSION NOT TO SCALE	
TITLE: 8LD SOIC NARROW BODY	DOCUMENT NO: 98ASB42564B	REV: U	
	CASE NUMBER: 751-07	07 APR 2005	
	STANDARD: JEDEC MS-012AA		

REVISION HISTORY

REVISION	DATE	DESCRIPTION OF CHANGES
3.0	3/2006	<ul style="list-style-type: none"> • Implemented Revision History page • Converted to Freescale format

How to Reach Us:

Home Page:

www.freescale.com

E-mail:

support@freescale.com

USA/Europe or Locations Not Listed:

Freescale Semiconductor
Technical Information Center, CH370
1300 N. Alma School Road
Chandler, Arizona 85224
+1-800-521-6274 or +1-480-768-2130
support@freescale.com

Europe, Middle East, and Africa:

Freescale Halbleiter Deutschland GmbH
Technical Information Center
Schatzbogen 7
81829 Muenchen, Germany
+44 1296 380 456 (English)
+46 8 52200080 (English)
+49 89 92103 559 (German)
+33 1 69 35 48 48 (French)
support@freescale.com

Japan:

Freescale Semiconductor Japan Ltd.
Headquarters
ARCO Tower 15F
1-8-1, Shimo-Meguro, Meguro-ku,
Tokyo 153-0064
Japan
0120 191014 or +81 3 5437 9125
support.japan@freescale.com

Asia/Pacific:

Freescale Semiconductor Hong Kong Ltd.
Technical Information Center
2 Dai King Street
Tai Po Industrial Estate
Tai Po, N.T., Hong Kong
+800 2666 8080
support.asia@freescale.com

For Literature Requests Only:

Freescale Semiconductor Literature Distribution Center
P.O. Box 5405
Denver, Colorado 80217
1-800-441-2447 or 303-675-2140
Fax: 303-675-2150
LDCForFreescaleSemiconductor@hibbertgroup.com

RoHS-compliant and/or Pb-free versions of Freescale products have the functionality and electrical characteristics of their non-RoHS-compliant and/or non-Pb-free counterparts. For further information, see <http://www.freescale.com> or contact your Freescale sales representative.

For information on Freescale's Environmental Products program, go to <http://www.freescale.com/epp>.

Information in this document is provided solely to enable system and software implementers to use Freescale Semiconductor products. There are no express or implied copyright licenses granted hereunder to design or fabricate any integrated circuits or integrated circuits based on the information in this document.

Freescale Semiconductor reserves the right to make changes without further notice to any products herein. Freescale Semiconductor makes no warranty, representation or guarantee regarding the suitability of its products for any particular purpose, nor does Freescale Semiconductor assume any liability arising out of the application or use of any product or circuit, and specifically disclaims any and all liability, including without limitation consequential or incidental damages. "Typical" parameters that may be provided in Freescale Semiconductor data sheets and/or specifications can and do vary in different applications and actual performance may vary over time. All operating parameters, including "Typicals", must be validated for each customer application by customer's technical experts. Freescale Semiconductor does not convey any license under its patent rights nor the rights of others. Freescale Semiconductor products are not designed, intended, or authorized for use as components in systems intended for surgical implant into the body, or other applications intended to support or sustain life, or for any other application in which the failure of the Freescale Semiconductor product could create a situation where personal injury or death may occur. Should Buyer purchase or use Freescale Semiconductor products for any such unintended or unauthorized application, Buyer shall indemnify and hold Freescale Semiconductor and its officers, employees, subsidiaries, affiliates, and distributors harmless against all claims, costs, damages, and expenses, and reasonable attorney fees arising out of, directly or indirectly, any claim of personal injury or death associated with such unintended or unauthorized use, even if such claim alleges that Freescale Semiconductor was negligent regarding the design or manufacture of the part.

Freescale™ and the Freescale logo are trademarks of Freescale Semiconductor, Inc. All other product or service names are the property of their respective owners.

© Freescale Semiconductor, Inc., 2006. All rights reserved.