

RIGHT ANGLE PLUG CLAMP TYPE

R112.165.000

CABLE 2.6/50+75 S

Series : SMC

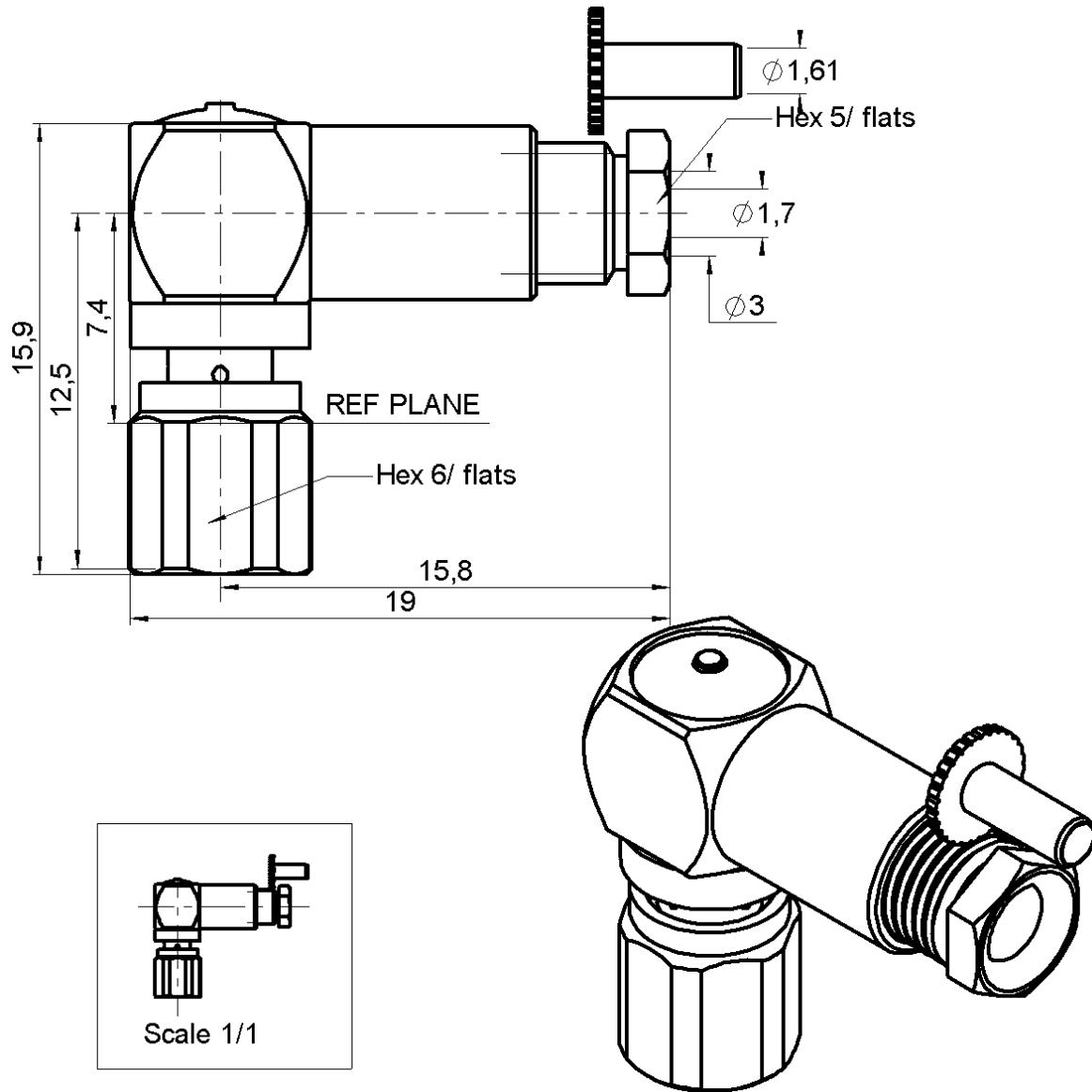

All dimensions are in mm.

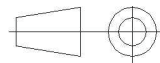

COMPONENTS	MATERIALS	PLATINGS (µm)
BODY	BRASS	GOLD 0.2 OVER NICKEL 2
CENTER CONTACT	BERYLLIUM COPPER	GOLD 1.3 OVER NICKEL 2
OUTER CONTACT	-	-
INSULATOR	PTFE	-
GASKET	CHLOROPRENE	-
OTHERS PARTS	BRASS	GOLD 0.2 OVER NICKEL 2
.	.	.
.	.	.

Issue : 0430 L

In the effort to improve our products, we reserve the right to make changes judged to be necessary.



RIGHT ANGLE PLUG CLAMP TYPE

R112.165.000

CABLE 2.6/50+75 S

Series : SMC

PACKAGING

Standard	Unit	Other
1	-	Contact us

SPECIFICATION

ELECTRICAL CHARACTERISTICS

Impedance		50 Ω
Frequency		0-10 GHz
VSWR	1.30 +	0.040 x F(GHz) Maxi
Insertion loss		0.25 √F(GHz) dB Maxi
RF leakage	- (62 - F(GHz)) dB mini
Voltage rating		335 Veff Maxi
Dielectric withstanding voltage		1000 Veff mini
Insulation resistance		1000 MΩ mini

CABLE ASSEMBLY

Stripping	a	b	c	d	e	f
mm	1.50	2.00	4.00	5.00	0.00	0.00

Assembly instruction :

Recommended cable(s)

RG 179
RG 187
RG 188
KX 22A
RG 316

MECHANICAL CHARACTERISTICS

Center contact retention		
Axial force – Mating end	10	N mini
Axial force – Opposite end	10	N mini
Torque	NA	N.cm mini

Cable retention

- pull off **110** N mini
- torque **NA** N.cm

TOOLING

Part Number	Description	Hexagon
.	.	.

Recommended torque

Mating	30	N.cm
Panel nut	NA	N.cm
Clamp nut	40	N.cm
A/F clamp nut	5.000	mm

OTHERS CHARACTERISTICS

Mating life	500	Cycles mini
Weight	4.300	g

ENVIRONMENTAL

Operating temperature	-55/+100	° C
Hermetic seal	NA	Atm.cm3/s
Panel leakage	NA	

Issue : 0430 L

In the effort to improve our products, we reserve the right to make changes judged to be necessary.



RIGHT ANGLE PLUG CLAMP TYPE

R112.165.000

CABLE 2.6/50+75 S

Series : SMC

COMPONENTS

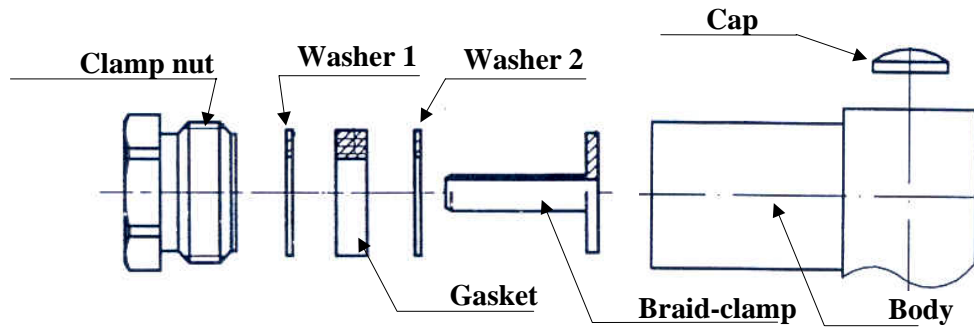

1

Slide the back nut, the first washer, the flat gasket, the second washer onto the cable.
Strip the cable.
Cut 2 slots in the jacket if necessary.

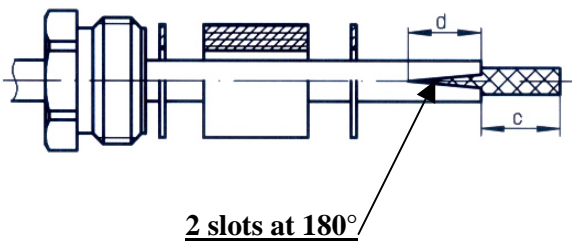

3

Screw sub-assembly into the connector body with the adapted wrench.
Recommended coupling torque (see connector TDS).
Solder the inner conductor.

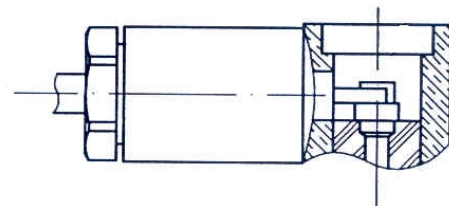

2

Slide the clamp braid sleeve.
Cut the braid flush with the clamp braid sleeve.
Strip off the dielectric.
(for cable 2.6/50 use knurled clamp, for cable 2.6/75 use smooth clamp.)

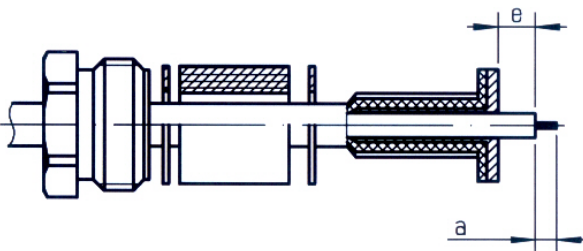

4

Place the cap into the body.
Press on the cap flush or slightly below the surface of the body assembly.

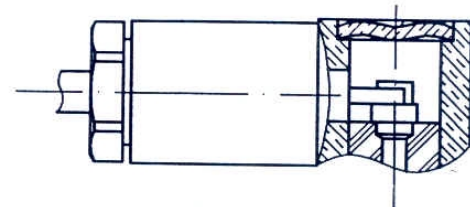

Issue : 0430 L

In the effort to improve our products, we reserve the right to make changes judged to be necessary.