



# Bridgelux® EB Series™ Edge

Product Data Sheet DS135

Lengths 570mm

CRIs: 80, 90

CCTs: 3000K, 3500K, 4000K, 5000K

Options: Adhesive tape



# Product Feature Map

Bridgelux EB Series Edge modules are fully engineered devices that provide consistent thermal and optical performance on an engineered mechanical platform. The linear products incorporate several features to simplify design integration and assembly. Please visit [www.bridgelux.com](http://www.bridgelux.com) for more information on the EB Series family of products.

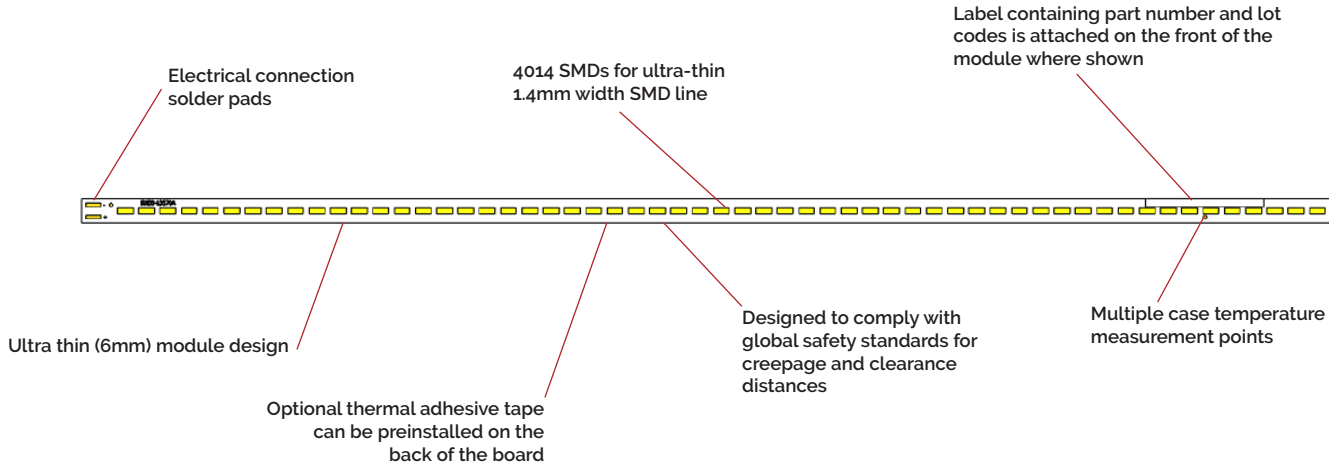

## Product Nomenclature

The part number designation for Bridgelux EB Series Edge is explained as follows:

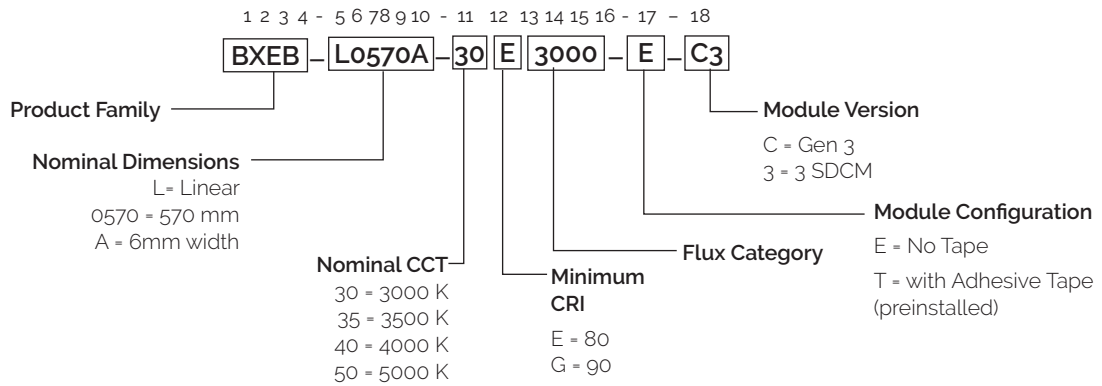

# Product Selection Guide

**Table 1: Product Performance ( $T_c = 25^\circ\text{C}$ )**

Part Number	Nominal CCT <sup>1</sup> (K)	Min CRI	Typical Flux <sup>2,3</sup> $T_c = 25^\circ\text{C}$ (lm)	Nominal Drive Current (mA)	Typical $V_f$ (V)	Typical Power (W)	Typical Efficacy (lm/W)
BXEB-L0570A-30E3000-E-C3	3000	80	2705	700	23.5	16.5	164
BXEB-L0570A-30G3000-E-C3		90	2350				143
BXEB-L0570A-35E3000-E-C3	3500	80	2705				164
BXEB-L0570A-35G3000-E-C3		90	2350				143
BXEB-L0570A-40E3000-E-C3	4000	80	2885				175
BXEB-L0570A-40G3000-E-C3		90	2485				151
BXEB-L0570A-50E3000-E-C3	5000	80	2885				175
BXEB-L0570A-50G3000-E-C3		90	2485				151

Notes for Table 1:

1. Nominal CCT as defined by ANSI C78.377-2011.
2. Data is at nominal test current where temperature of center case temperature point  $T_c = 25^\circ\text{C}$ .
3. Bridgelux maintains a  $\pm 7\%$  tolerance on flux data.
4. Product performance does not change for configurations with the adhesive tape preinstalled

# Electrical Characteristics

**Table 2: Electrical Characteristics**

Part Number	Drive Current (mA)	Forward Voltage $T_{c2} = 25^{\circ}\text{C (V)}$ <sup>1, 2, 3</sup>			Typical Coefficient of Forward Voltage <sup>4</sup> $\Delta V_f / \Delta T$ (mV/°C)	Driver Selection Voltages <sup>5</sup> (V)	
		Minimum	Typical	Maximum		$V_f$ Min, Hot $T_{c2} = 85^{\circ}\text{C (V)}$	$V_f$ Max, Cold $T_{c2} = -40^{\circ}\text{C (V)}$
BXEB-L0570A-xy3000-z-C3	700	21.9	23.5	25.1	-6.2	21.5	25.5
	1400	25.4	27.3	29.2	-6.2	25.0	29.6

Notes for Table 2:

1. Voltage minimum and maximum are provided for reference only and are not a guarantee of performance.
2. Bridgelux maintains a tolerance of  $\pm 0.1\text{ V}$  on forward voltage data.
3. This product has been designed and manufactured per IEC 62031:2014. The working voltage designated for the insulation is 60 V d.c. The maximum allowable voltage across the module must be determined in the end product application.
4. Typical coefficient of forward voltage tolerance is  $\pm 0.1\text{ mV}$  for nominal current.
5.  $V_f$  min hot and max cold values are provided as reference only and are not guaranteed. These values are provided to aid in driver design and selection over the operating range of the product.
6. Part Number variables xx, y, and z represent CCT, CRI, and configuration options, respectively

# Absolute Maximum Ratings

**Table 3: Maximum Ratings**

Parameter	Maximum Rating
Storage Temperature	-40°C to 85°C
Operating Case Temperature (Tc)	85°C
Soldering Temperature	350°C or lower for a maximum of 5 seconds
Maximum Reverse Voltage	Modules are not designed to be driven in reverse bias
Maximum Drive Current	1400 mA

Notes for Table 3:

- 1. For IEC 62717 requirement, please consult your Bridgelux sales representative.
- 2. Lumen maintenance (L70) and lifetime predictions are valid for drive current and case temperature conditions used for LM-80 testing as included in the applicable LM-80 test report for the SMDs used in the modules. Contact your Bridgelux sales representatives for LM-80 report.

# Performance Curves

Figure 1: Current vs. Forward Voltage,  $T_c=25^\circ\text{C}$

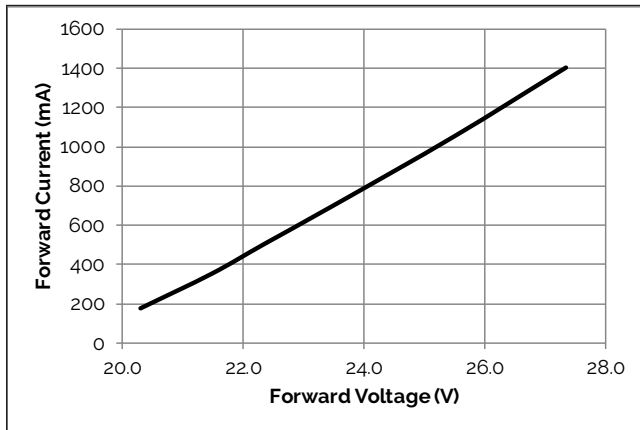

Figure 2: Relative Flux vs. Current,  $T_c=25^\circ\text{C}$

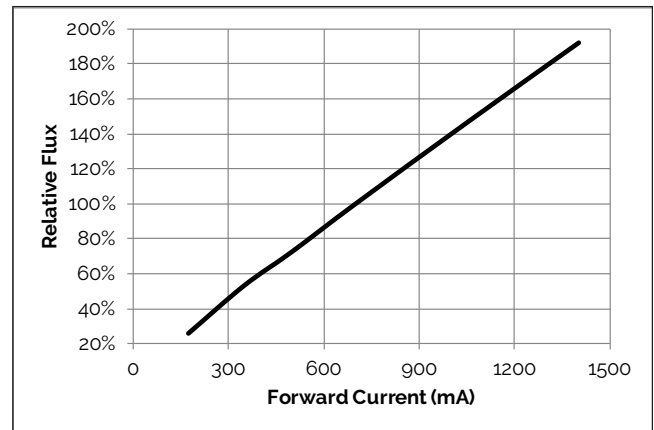

Figure 3: Relative Voltage vs. Case Temperature

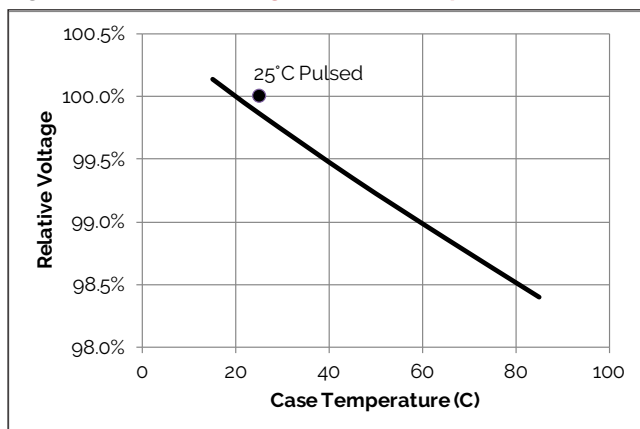
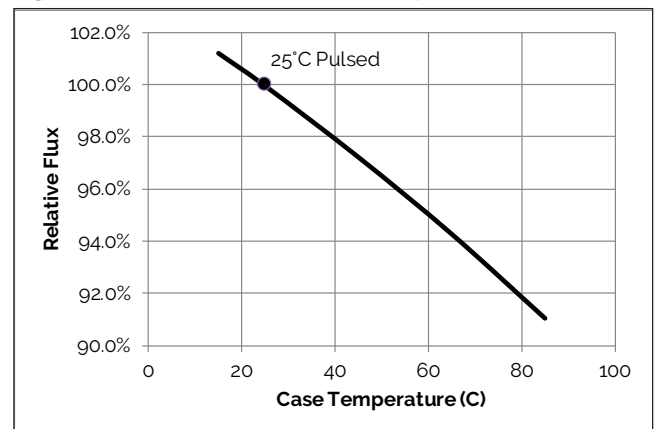
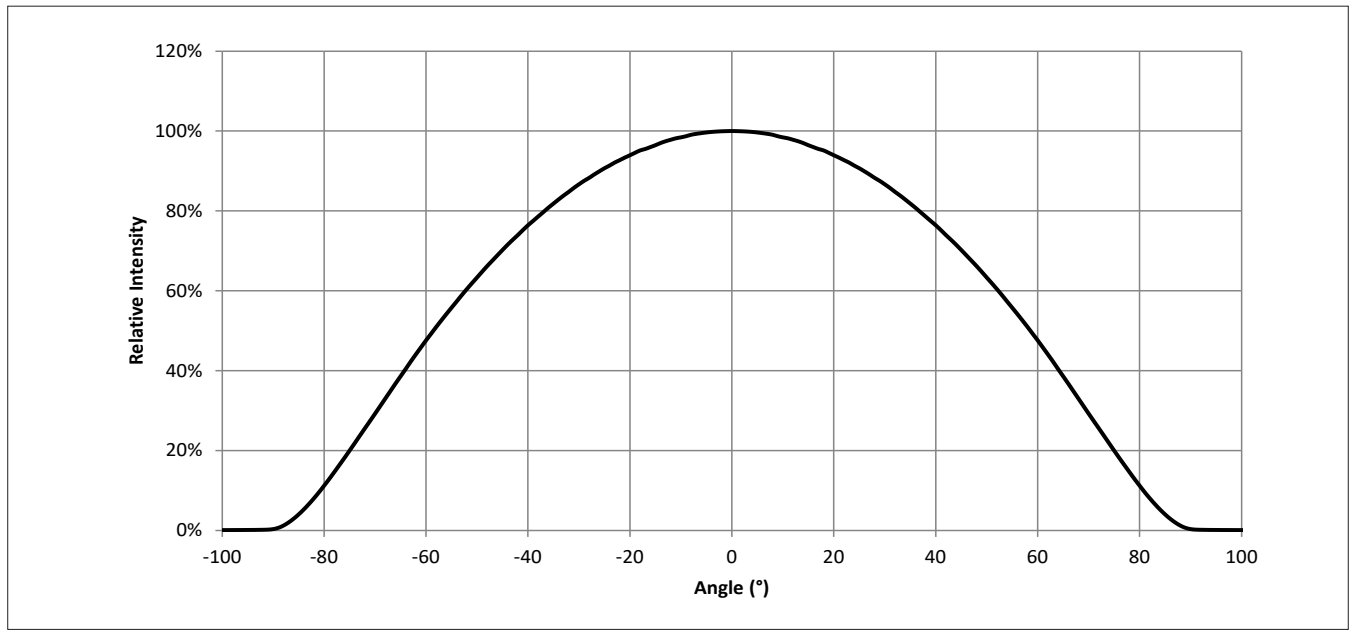

Figure 4: Relative Flux vs. Case Temperature



# Typical Radiation Pattern

**Figure 5: Typical Spatial Radiation Pattern**



Notes for Figure 5:

1. Typical viewing angle is 120°.
2. The viewing angle is defined as the off axis angle from the centerline where  $I_v$  is  $\frac{1}{2}$  of the peak value.

# Typical Color Spectrum

Figure 6: Typical Color Spectra, 80 CRI

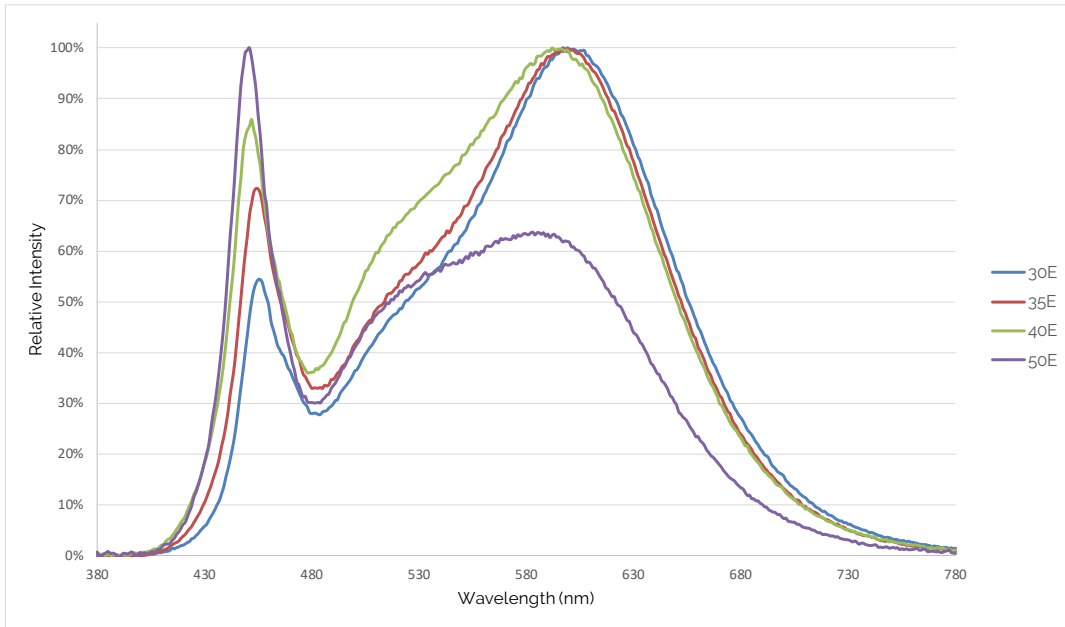
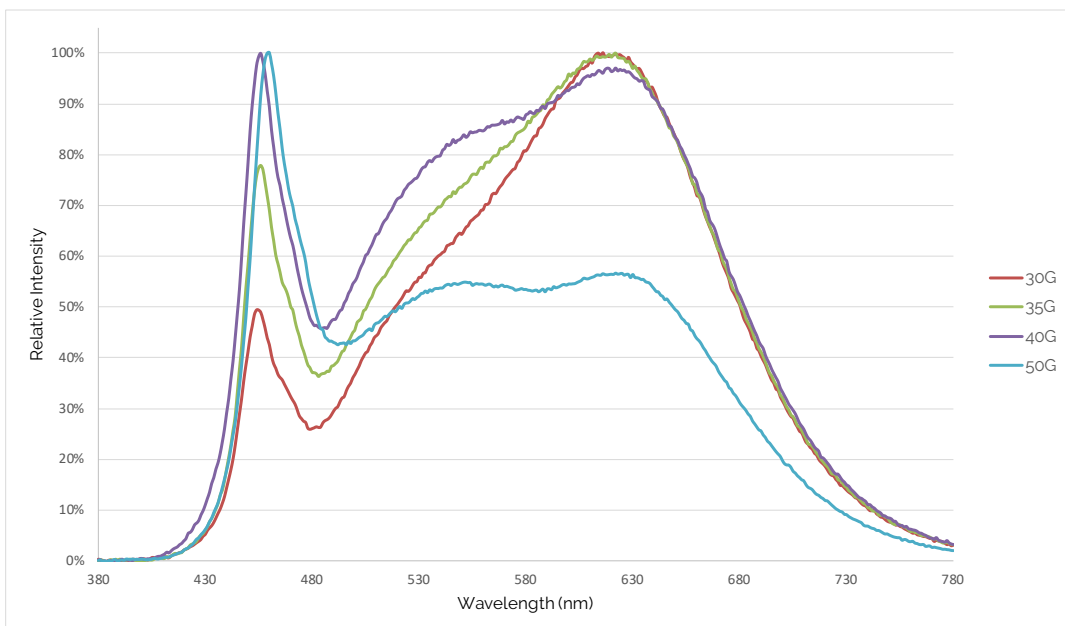

Figure 7: Typical Color Spectra, 90 CRI



Note for Figures 6 & 7:

1. Color spectra measured at nominal current for  $T_c = 65^\circ\text{C}$



# Mechanical Dimensions

**Figure 8: Drawing Overview**

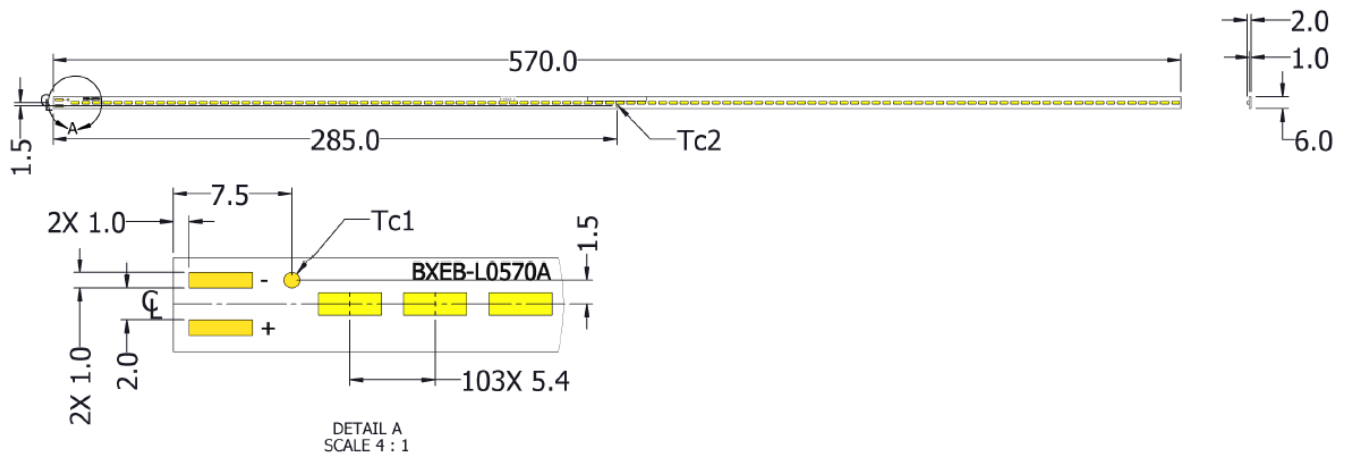

Notes for Figure 8:

1. Solder pads are labeled "+" to denote positive polarity, and "-" to denote negative polarity.
2. Drawing dimensions are in millimeters.
3. Refer to Bridgelux assembly drawing 15-000721 for complete product configuration

**Table 4: Mechanical Dimensions**

Parameter	Specification	Unit
Length	570.0	mm
Width	6.0	mm
Overall Thickness	2.0	mm
PCB thickness	1.0	mm

**Table 5: Wiring Recommendations**

Parameter	Specification
Wire Size	24-26 AWG
Wire Strip Length	2-3 mm

# Color Binning Information

**Figure 9: 3 SDCM Color Bins in CIE 1931 xy Color Space**

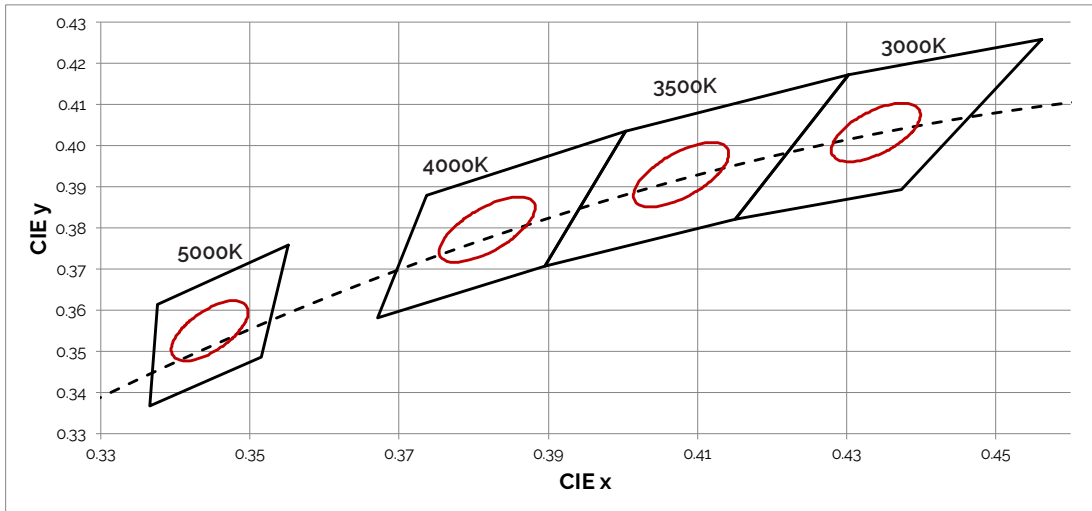

**Table 6: Bin Coordinates and Associated Typical CCT**

Bin Code	3000K	3500 K	4000K	5000K
C3 (3 SDCM) CCT Range	2968K - 3136K	3369K - 3586K	3851K - 4130K	4835K - 5215K
Center Point (x, y)	(0.434, 0.403)	(0.407, 0.392)	(0.382, 0.380)	(0.3445, 0.355)
ANSI Bin (for reference only)	(2870K - 3220K)	(3220K - 3710K)	(3710K - 4260K)	(4745K - 5311K)

Notes for Table 6:

1. Color binning at solder point temperature Tsp of SMDs at 25°C.
2. Bridgelux maintains a tolerance of  $\pm 0.007$  on x and y color coordinates in the CIE 1931 color space.
3. Quadrangular ANSI bins shown for reference only

# Packaging and Labeling

**Figure 8: EB Series Packaging and Labeling**

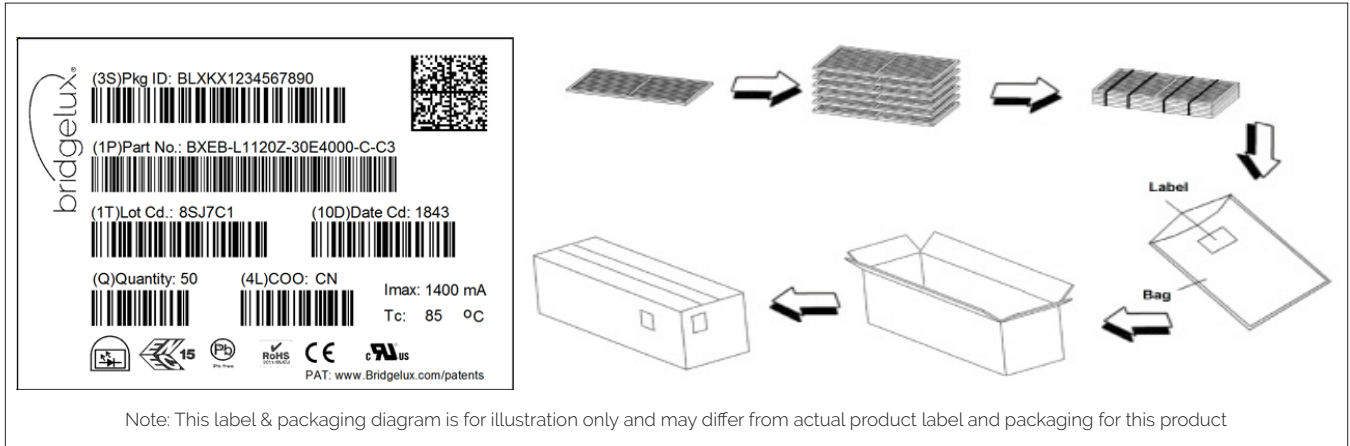

**Table 7: Packaging Structure**

	Tray	Box
Quantity	26 modules	390 modules
Dimension	63 cm x 39 cm x 2.4 cm	65.5 cm x 41.5 cm x 15.5 cm
Weight	N/A	8.15 kg

# Design Resources

## Application Notes

Bridgelux has developed a comprehensive set of application notes and design resources to assist customers in successfully designing with the EB Series product family. For a list of resources under development, visit [www.bridgelux.com](http://www.bridgelux.com).

## Optical Source Models

Optical source models and ray set files are available for all Bridgelux products. For a list of available formats, visit [www.bridgelux.com](http://www.bridgelux.com).

## 3D CAD Models

Three dimensional CAD models depicting the product outline of all Bridgelux EB Series LED linears are available in both IGES and STEP formats. Please contact your Bridgelux sales representative for assistance.

# Precautions

## CAUTION: CHEMICAL EXPOSURE HAZARD

Exposure to some chemicals commonly used in luminaire manufacturing and assembly can cause damage to the LED linear. Please consult Bridgelux Application Note for additional information.

## CAUTION: EYE SAFETY

Eye safety classification for the use of Bridgelux EB Series is in accordance with IEC/TR62778: Application of IEC 62471 for the assessment of blue light hazard to light sources and luminaires. EB Series linears are classified as Risk Group 1 (TBD) when operated at or below the maximum drive current. Please use appropriate precautions. It is important that employees working with LEDs are trained to use them safely.

## CAUTION: RISK OF BURN

Do not touch the EB Series linears during operation. Allow the linear to cool for a sufficient period of time before handling. The EB Series linears may reach elevated temperatures such that could burn skin when touched.

## CAUTION

### CONTACT WITH LIGHT EMITTING SURFACE (LES)

Avoid any contact with the LES. Do not touch the LES of the linear or apply stress to the LES (yellow phosphor resin area). Contact may cause damage to the linear.

Optics and reflectors must not be mounted in contact with the LES (yellow phosphor resin area). Optical devices may be mounted on the top surface of the EB Series linear. Use the mechanical features of the linear housing, edges and/or mounting holes to locate and secure optical devices as needed.

# Disclaimers

## STANDARD TEST CONDITIONS

Unless otherwise stated, linear testing is performed at the nominal drive current.

## MINOR PRODUCT CHANGE POLICY

The rigorous qualification testing on products offered by Bridgelux provides performance assurance. Slight cosmetic changes that do not affect form, fit, or function may occur as Bridgelux continues product optimization.

# About Bridgelux: Bridging Light and Life™

At Bridgelux, we help companies, industries and people experience the power and possibility of light. Since 2002, we've designed LED solutions that are high performing, energy efficient, cost effective and easy to integrate. Our focus is on light's impact on human behavior, delivering products that create better environments, experiences and returns—both experiential and financial. And our patented technology drives new platforms for commercial and industrial luminaires.

**For more information about the company, please visit**

**[bridgelux.com](http://bridgelux.com)**

**[twitter.com/Bridgelux](https://twitter.com/Bridgelux)**

**[facebook.com/Bridgelux](https://facebook.com/Bridgelux)**

**[youtube.com/user/Bridgelux](https://youtube.com/user/Bridgelux)**

**[linkedin.com/company/bridgelux-inc-\\_2](https://linkedin.com/company/bridgelux-inc-_2)**

**WeChat ID: BridgeluxInChina**



46430 Fremont Blvd  
Fremont, CA 94538 USA  
Tel (925) 583-8400  
Fax (925) 583-8401  
**[www.bridgelux.com](http://www.bridgelux.com)**

© 2020 Bridgelux, Inc. All rights reserved. Product specifications are subject to change without notice. Bridgelux and the Bridgelux stylized logo design are registered trademarks of Bridgelux, Inc. EB Series and Bridging Light and Life are trademarks of Bridgelux, Inc. All other trademarks are the property of their respective owners.

**Bridgelux EB Series Edge Data Sheet DS135 Rev. A (06/2020)**