

## **TPS74701EVM-177 and TPS74801EVM-177**

---



---

This user's guide describes the characteristics, operation, and use of the TPS74x01EVM-177 evaluation module (EVM). This EVM contains either the TPS74701 or TPS74801 low-dropout linear regulator IC. This user's guide includes EVM specifications, recommended test setup, test results, bill of materials (BOM), and a schematic diagram.

### **Contents**

1	Introduction .....	1
2	Input/Output Connector Descriptions.....	2
3	Board Layout .....	5
4	Bill of Materials and Schematic .....	7

### **List of Figures**

1	TPS74701 and TPS74801 Start-up in 1 mS with PG .....	3
2	TPS74701 and TPS74801 Start-up in 10 mS with PG .....	4
3	Top Assembly Layer.....	5
4	Top Layer .....	5
5	Bottom Layer .....	6
6	Schematic.....	8

### **List of Tables**

1	Typical Performance Specification Summary .....	2
5	HPA177 Bill of Materials .....	7

## **1 Introduction**

The Texas Instruments TPS74x01EVM-177 evaluation module uses the TPS74701 or TPS74801 low-dropout linear regulator IC. These regulators require a low-power bias voltage,  $V_{BIAS}$ , and a power input voltage,  $V_{IN}$ . These two regulators are capable of providing output voltages down to 0.8 V and have an integrated supervisory circuit with open-drain output that goes to high impedance when the output voltage reaches regulation (power good or PG). The TPS74701 and TPS74801 can provide up to 0.5 A and 1.5 A of output current, respectively, and each has a soft start (SS) pin which allows the user to set the output voltage's linear ramp rate at startup. The goal of the EVM is to facilitate evaluation of the TPS74x01 ICs.

## 1.1 Performance Specification Summary

Table 1 provides a summary of the TPS74x01EVM-177 performance specifications. All specifications are given for an ambient temperature of 25°C.

**Table 1. Typical Performance Specification Summary**

	CONDITION	VOLTAGE RANGE (V)			CURRENT RANGE (mA)		
		MIN	TYP	MAX	MIN	TYP	MAX
V <sub>BIAS</sub> supply	TPS74801EVM-177 (HPA177-001), V <sub>IN</sub> = V <sub>BIAS</sub> , I <sub>OUT</sub> = 1.5A	2.83 <sup>(1)</sup>	5	5.5		5	
	TPS74701EVM-177 (HPA177-002), V <sub>IN</sub> = V <sub>BIAS</sub> , I <sub>OUT</sub> = 0.5A	2.7 <sup>(1)</sup>	5	5.5		5	
V <sub>IN</sub> supply	TPS74801EVM-177 (HPA177-001), V <sub>BIAS</sub> - V <sub>OUT</sub> ≥ 3.25 V, I <sub>OUT</sub> = 1.5A	1.395 <sup>(1)</sup>		5.5 <sup>(2)</sup>			1500
	TPS74701EVM-177 (HPA177-002), V <sub>BIAS</sub> - V <sub>OUT</sub> ≥ 1.62 V, I <sub>OUT</sub> = 0.5A	1.35 <sup>(1)</sup>		5.5 <sup>(2)</sup>			500
V <sub>OUT</sub>	TPS74801EVM-177 (HPA177-001)	1.17 <sup>(3)</sup>	1.20	1.23 <sup>(3)</sup>			1500 <sup>(2)</sup>
V <sub>OUT</sub>	TPS74701EVM-177 (HPA177-002)	1.17 <sup>(3)</sup>	1.20	1.23 <sup>(3)</sup>			500 <sup>(2)</sup>

- (1) This is the minimum voltage to provide the maximum output current in the table assuming the typical V<sub>BIAS</sub> voltage is applied. Lower output currents are achievable with lower V<sub>IN</sub> and V<sub>BIAS</sub> voltages. See the data sheet for V<sub>IN</sub> to V<sub>OUT</sub> and V<sub>BIAS</sub> to V<sub>OUT</sub> dropout data.
- (2) Linear regulator power dissipation is computed as P<sub>D</sub> = (V<sub>IN</sub> - V<sub>OUT</sub>) × I<sub>OUT</sub>. As specified in the data sheet, the regulator's package has a finite power dissipation rating depending on the ambient temperature, board type, and airflow. Using V<sub>IN</sub> and/or V<sub>OUT</sub> voltages other than the typical voltages recommended in the table or using the EVM in an environment with an ambient temperature higher than 25°C significantly reduces the maximum allowed output current. See the data sheet for the regulator package's thermal resistance data, and see TI application report *Digital Designer's Guide to Linear Voltage Regulators and Thermal Management (SLVA118)* for a full explanation.
- (3) The EVM uses ±1% feedback resistors. Therefore, the EVM output tolerance is the ±2% internal reference tolerance plus  $2 \times (1 - V_{REF}/V_{OUT}) \times TOL_{FBRES} = 2 \times (1 - 0.8 \text{ V}/1.2 \text{ V}) \times \pm 1\% = 0.67\%$  or ±2.67%. For tighter output tolerance, tighter tolerance feedback resistors must be used.

## 1.2 Modifications

To aid user customization of the EVM, the board was designed with devices having 0603 or larger footprints. A real implementation likely occupies less total board space.

Changing components can improve or degrade EVM performance. For example, adding a larger output capacitor reduces output voltage undershoot but lengthens response time after a load transient event. Adding a larger input capacitor reduces droop at the V<sub>IN</sub> pin that inductive leads from the V<sub>IN</sub> power supply may cause during a load transient.

## 2 Input/Output Connector Descriptions

**J1-VIN/GND** This terminal block has both a positive and ground return connection to the power input (V<sub>IN</sub>) supply. The leads to the input supply should be twisted and kept as short as possible.

**J2-GND** This header is the return connection for the bias (V<sub>BIAS</sub>) supply.

**J3-VIN** This header is a positive connection to the power input supply (V<sub>IN</sub>). Its use is recommended for low power (i.e., I<sub>IN</sub> = I<sub>OUT</sub> < 1A) evaluation or as a voltage test point.

**J4-VBIAS** This header is the positive connection for the bias (V<sub>BIAS</sub>) supply.

**J5-GND** This header is a ground return connection to the power input (V<sub>IN</sub>) supply. Its use is recommended for low power (i.e., I<sub>IN</sub> = I<sub>OUT</sub> < 1A) evaluation or as a ground test point.

**J6-VOUT** This header is the positive connection for the output load on V<sub>OUT</sub>. Its use is recommended for low power (i.e., I<sub>IN</sub> = I<sub>OUT</sub> < 1A) evaluation only or as a voltage test point.

**J7-GND** This header is the ground return connection for the output load. Its use is recommended for low power (i.e., I<sub>IN</sub> = I<sub>OUT</sub> < 1A) evaluation or as a ground test point.

**J8–VOUT/GND** This terminal block has both a positive and ground return connection for the output load. The leads to the output load should be twisted and kept as short as possible.

**J9–TRACK IN** This header is not populated on the TPS74701 or TPS74801 EVMs.

**J10–EN** This header is a connection to the enable pin (EN), which is also connected to the middle pin of S1. When S1 is OFF, the EN pin is pulled to ground through pull-down resistor. When applying an external signal to drive EN, S1 should be in the OFF position.

**J11–GND** This header is a ground connection.

**JP1– 1ms/Simult vs. 10ms/Ratio** For the TPS74701 and TPS74801, this jumper allows the user to choose either 1 ms or 10 ms soft start time for the output voltage. Leaving the jumper open results in the output voltage ramping up with default soft-start time of 500 us.

**S1** - This switch connects to the EN pin of the IC and allows the user to turn the IC ON or OFF by connecting enable to either  $V_{BIAS}$  or ground through a pull-down resistor.

**TP1** - This is a Kelvin test point to  $V_{IN}$ .

**TP2** - This is a Kelvin test point to IC ground.

**TP3** - This is a Kelvin test point to  $V_{OUT}$ .

## 2.1 Test Setup

The absolute maximum voltage allowed on the BIAS, IN, or EN pins is 6 V. The TPS74701 and TPS74801 devices are designed to operate with  $V_{IN}$  and  $V_{BIAS}$  less than or equal to 5.5 V. To enable the regulator, switch S1 to the ON position. When connecting external loads, use short, twisted leads in order to minimize DC drop at the connector and/or inductive voltage dip after a transient load is removed.

## 2.2 Test Results

The figures below show the test results at  $T_A = 25^\circ\text{C}$  using this EVM:

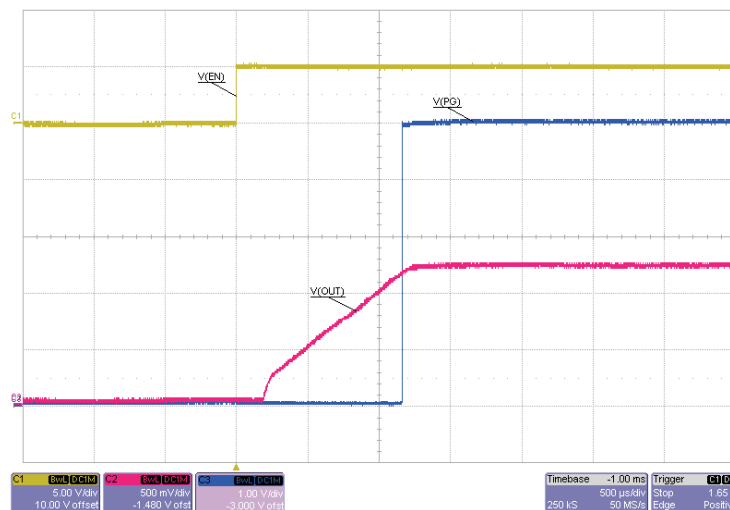

A  $V_{IN} = 1.8\text{ V}$ ,  $V_{BIAS} = 5.0\text{ V}$ ,  $I_{OUT} = 500\text{ m A}$ .

**Figure 1. TPS74701 and TPS74801 Start-up in 1 ms with PG**

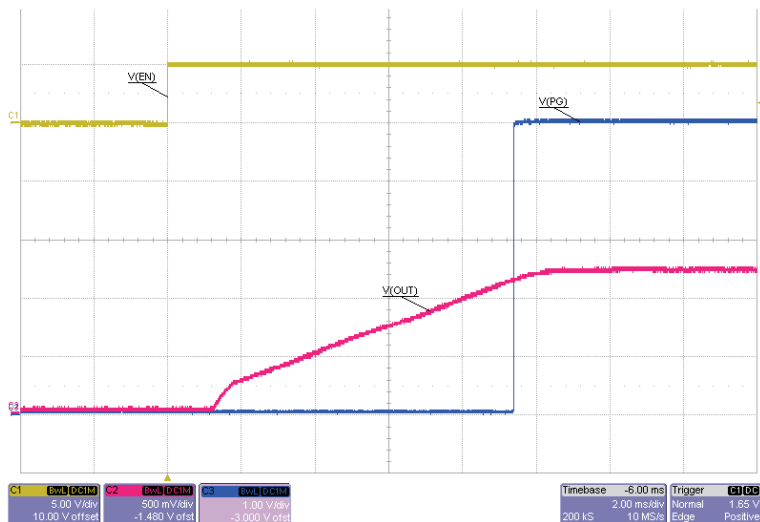

A  $V_{IN} = 1.8\text{ V}$ ,  $V_{BIAS} = 5.0\text{ V}$ ,  $I_{OUT} = 500\text{ mA}$ .

**Figure 2. TPS74701 and TPS74801 Start-up in 10 ms with PG**

### 3 Board Layout

Board layout is important for best PSR and lowest noise. [Figure 3](#), [Figure 4](#), and [Figure 5](#) show the board layout for the HPA177 PWB. The switching nodes with high-frequency noise are isolated from the noise-sensitive feedback circuitry, and careful attention has been given to the routing of high-frequency current loops. See the data sheet for more specific layout guidelines.

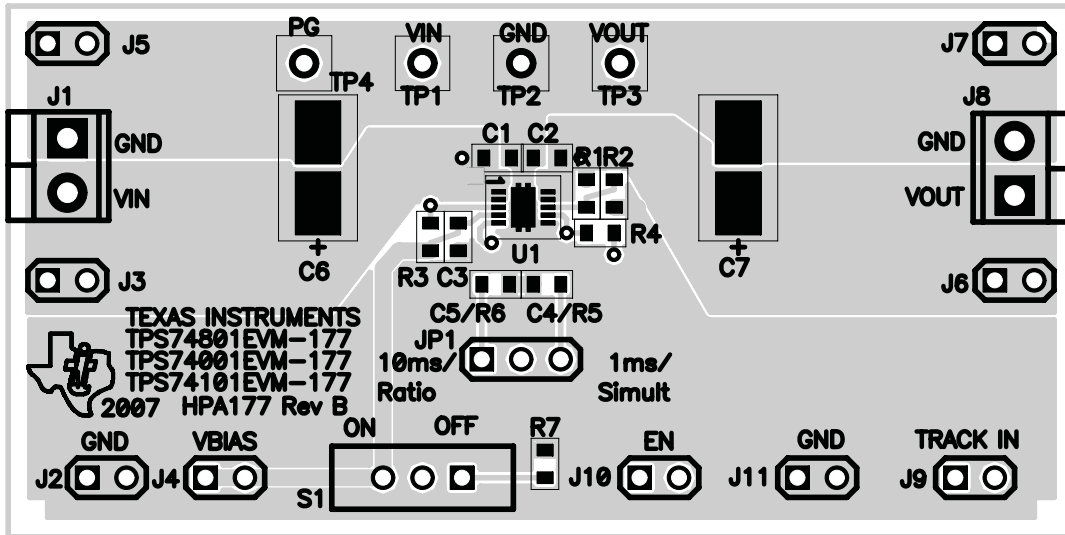

Figure 3. Top Assembly Layer

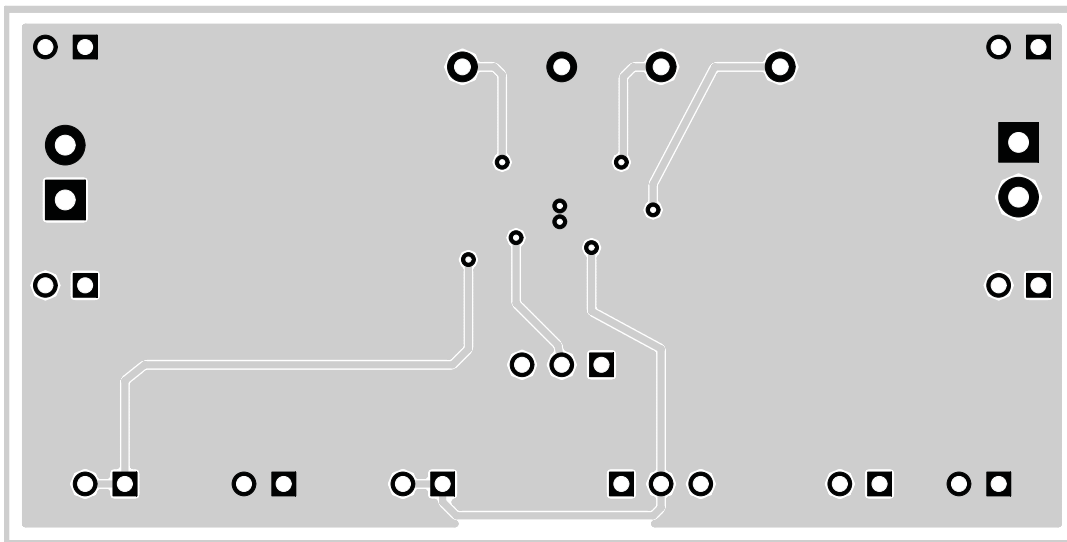

Figure 4. Top Layer

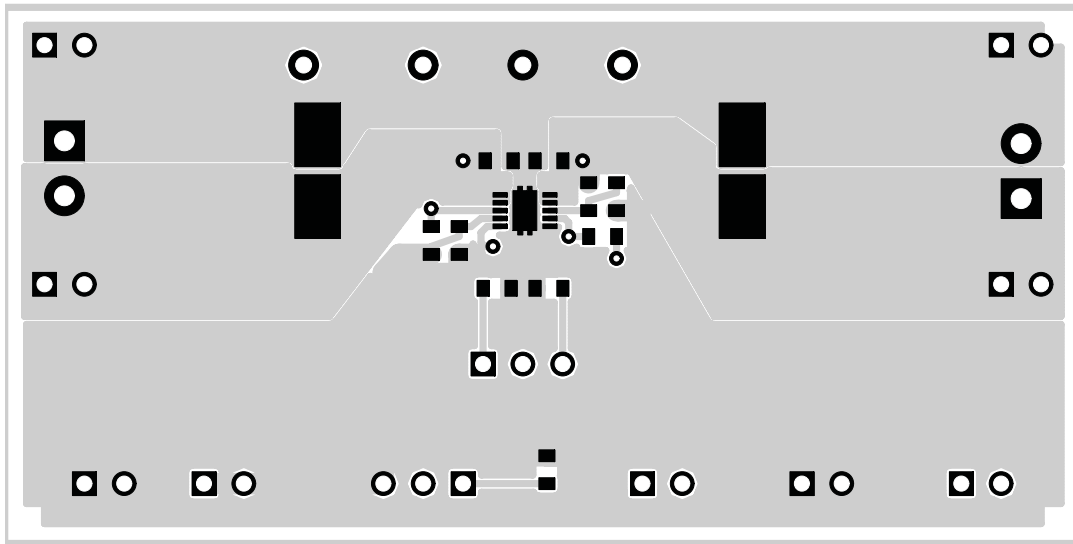

Figure 5. Bottom Layer

**4 Bill of Materials and Schematic**
**Table 5. HPA177 Bill of Materials**

COUNT		RefDes	Value	DESCRIPTION	SIZE	Part Number	MFR
-001	-002						
2	2	C1	1.0uF	Capacitor, Ceramic, 25V, X5R, 10%	0603	C1608X5R1E105K	TDK
2	2	C3, C2	4.7uF	Capacitor, Ceramic, 6.3V, X5R, 10%	0603	C1608X5R0J475K	TDK
1	1	C4	560pF	Capacitor, Ceramic, 50V, C0G, 5%	0603	C1608C0G1H561J	TDK
1	1	C5	5600pF	Capacitor, Ceramic, 50V, X7R, 10%	0603	GRM188R71H562KA01 D	muRata
0	0	C6, C7	Open	Capacitor, Multi-pattern, 603-D case	7343 (D)		
2	2	J1**, J8** J2 - J7, J10,		Terminal Block, 2 pin, 6A, 3.5mm	0.27 x 0.25	ED1514	OST
8	8	J11		Header, 2 pin, 100mil spacing, (36-pin strip)	0.100 x 2	PTC36SAAN	Sullins
0	0	J9		Header, 2 pin, 100mil spacing, (36-pin strip)	0.100 x 2	PTC36SAAN	Sullins
1	1	JP1		Header, 3 pin, 100mil spacing, (36-pin strip)	0.100 x 3	PTC36SAAN	Sullins
1	1	R1	2.49k	Resistor, Chip, 1/16W, 1%	0603	Std	Std
1	1	R2	4.99k	Resistor, Chip, 1/16W, 1%	0603	Std	Std
1	1	R3	10.0k	Resistor, Chip, 1/16W, 1%	0603	Std	Std
0	0	R4	4.99k	Resistor, Chip, 1/16W, 1%	0603	Std	Std
0	0	R5	10.0k	Resistor, Chip, 1/16W, 1%	0603	Std	Std
0	0	R6	1.78k	Resistor, Chip, 1/16W, 1%	0603	Std	Std
1	1	R7	100k	Resistor, Chip, 1/16W, 1%	0603	Std	Std
1	1	S1		Switch, 1P2T, Slide, PC mount, 200mA	0.46 x 0.16	EG1218	E_Switch
3	3	TP1, TP3, TP4		Test Point, Red, Thru Hole Color Keyed	0.100 x 0.100	5000	Keystone
1	1	TP2		Test Point, Black, Thru Hole Color Keyed	0.100 x 0.100	5001	Keystone
1	0	U1		IC, 1.5A LDO Regulator with Soft-Start	SON-10	TPS74801DRC	TI
0	1			IC, 500mA LDO With Programmable Soft Start	SON-10	TPS74701DRC	TI
1	1	--		PCB, 2.7 In x 1.345 In x 0.062 In		HPA177	Any
1	1	--		Shunt, 100mil, Black	0.100	929950-00	

## 5.1 Schematic Drawing

Figure 6 is the schematic for the TPS74x01EVM-177.

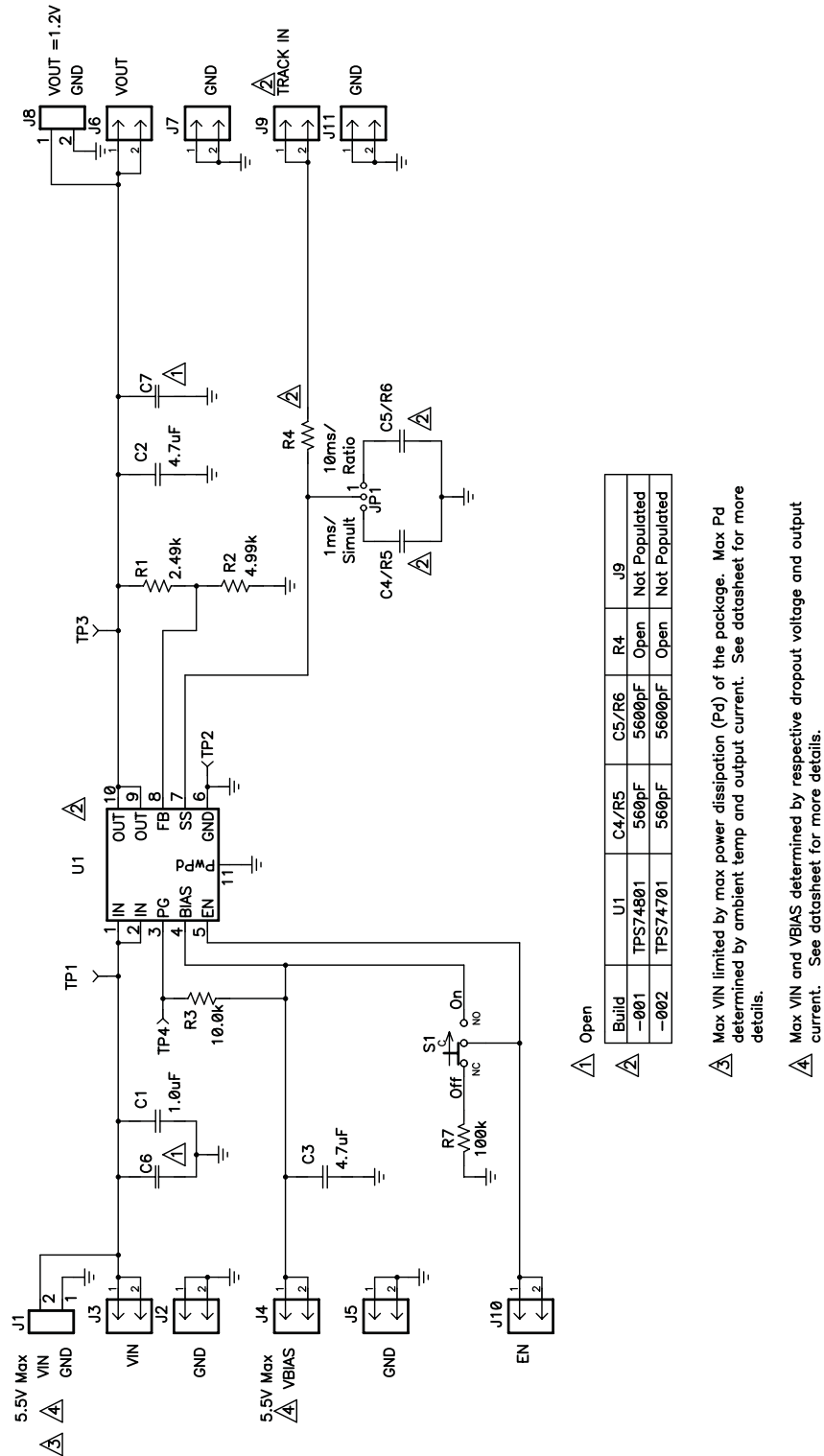

Figure 6. Schematic



## EVALUATION BOARD/KIT IMPORTANT NOTICE

Texas Instruments (TI) provides the enclosed product(s) under the following conditions:

This evaluation board/kit is intended for use for **ENGINEERING DEVELOPMENT, DEMONSTRATION, OR EVALUATION PURPOSES ONLY** and is not considered by TI to be a finished end-product fit for general consumer use. Persons handling the product(s) must have electronics training and observe good engineering practice standards. As such, the goods being provided are not intended to be complete in terms of required design-, marketing-, and/or manufacturing-related protective considerations, including product safety and environmental measures typically found in end products that incorporate such semiconductor components or circuit boards. This evaluation board/kit does not fall within the scope of the European Union directives regarding electromagnetic compatibility, restricted substances (RoHS), recycling (WEEE), FCC, CE or UL, and therefore may not meet the technical requirements of these directives or other related directives.

Should this evaluation board/kit not meet the specifications indicated in the User's Guide, the board/kit may be returned within 30 days from the date of delivery for a full refund. **THE FOREGOING WARRANTY IS THE EXCLUSIVE WARRANTY MADE BY SELLER TO BUYER AND IS IN LIEU OF ALL OTHER WARRANTIES, EXPRESSED, IMPLIED, OR STATUTORY, INCLUDING ANY WARRANTY OF MERCHANTABILITY OR FITNESS FOR ANY PARTICULAR PURPOSE.**

The user assumes all responsibility and liability for proper and safe handling of the goods. Further, the user indemnifies TI from all claims arising from the handling or use of the goods. Due to the open construction of the product, it is the user's responsibility to take any and all appropriate precautions with regard to electrostatic discharge.

**EXCEPT TO THE EXTENT OF THE INDEMNITY SET FORTH ABOVE, NEITHER PARTY SHALL BE LIABLE TO THE OTHER FOR ANY INDIRECT, SPECIAL, INCIDENTAL, OR CONSEQUENTIAL DAMAGES.**

TI currently deals with a variety of customers for products, and therefore our arrangement with the user **is not exclusive.**

TI assumes **no liability for applications assistance, customer product design, software performance, or infringement of patents or services described herein.**

Please read the User's Guide and, specifically, the Warnings and Restrictions notice in the User's Guide prior to handling the product. This notice contains important safety information about temperatures and voltages. For additional information on TI's environmental and/or safety programs, please contact the TI application engineer or visit [www.ti.com/esh](http://www.ti.com/esh).

No license is granted under any patent right or other intellectual property right of TI covering or relating to any machine, process, or combination in which such TI products or services might be or are used.

### FCC Warning

This evaluation board/kit is intended for use for **ENGINEERING DEVELOPMENT, DEMONSTRATION, OR EVALUATION PURPOSES ONLY** and is not considered by TI to be a finished end-product fit for general consumer use. It generates, uses, and can radiate radio frequency energy and has not been tested for compliance with the limits of computing devices pursuant to part 15 of FCC rules, which are designed to provide reasonable protection against radio frequency interference. Operation of this equipment in other environments may cause interference with radio communications, in which case the user at his own expense will be required to take whatever measures may be required to correct this interference.

### EVM WARNINGS AND RESTRICTIONS

It is important to operate this EVM within the input voltage range of 3 V to 5 V and the output voltage range of 3 V to 3.3 V.

Exceeding the specified input range may cause unexpected operation and/or irreversible damage to the EVM. If there are questions concerning the input range, please contact a TI field representative prior to connecting the input power.

Applying loads outside of the specified output range may result in unintended operation and/or possible permanent damage to the EVM. Please consult the EVM User's Guide prior to connecting any load to the EVM output. If there is uncertainty as to the load specification, please contact a TI field representative.

During normal operation, some circuit components may have case temperatures greater than 25°C. The EVM is designed to operate properly with certain components above 25°C as long as the input and output ranges are maintained. These components include but are not limited to linear regulators, switching transistors, pass transistors, and current sense resistors. These types of devices can be identified using the EVM schematic located in the EVM User's Guide. When placing measurement probes near these devices during operation, please be aware that these devices may be very warm to the touch.

Mailing Address: Texas Instruments, Post Office Box 655303, Dallas, Texas 75265  
Copyright © 2007, Texas Instruments Incorporated

## IMPORTANT NOTICE

Texas Instruments Incorporated and its subsidiaries (TI) reserve the right to make corrections, modifications, enhancements, improvements, and other changes to its products and services at any time and to discontinue any product or service without notice. Customers should obtain the latest relevant information before placing orders and should verify that such information is current and complete. All products are sold subject to TI's terms and conditions of sale supplied at the time of order acknowledgment.

TI warrants performance of its hardware products to the specifications applicable at the time of sale in accordance with TI's standard warranty. Testing and other quality control techniques are used to the extent TI deems necessary to support this warranty. Except where mandated by government requirements, testing of all parameters of each product is not necessarily performed.

TI assumes no liability for applications assistance or customer product design. Customers are responsible for their products and applications using TI components. To minimize the risks associated with customer products and applications, customers should provide adequate design and operating safeguards.

TI does not warrant or represent that any license, either express or implied, is granted under any TI patent right, copyright, mask work right, or other TI intellectual property right relating to any combination, machine, or process in which TI products or services are used. Information published by TI regarding third-party products or services does not constitute a license from TI to use such products or services or a warranty or endorsement thereof. Use of such information may require a license from a third party under the patents or other intellectual property of the third party, or a license from TI under the patents or other intellectual property of TI.

Reproduction of TI information in TI data books or data sheets is permissible only if reproduction is without alteration and is accompanied by all associated warranties, conditions, limitations, and notices. Reproduction of this information with alteration is an unfair and deceptive business practice. TI is not responsible or liable for such altered documentation. Information of third parties may be subject to additional restrictions.

Resale of TI products or services with statements different from or beyond the parameters stated by TI for that product or service voids all express and any implied warranties for the associated TI product or service and is an unfair and deceptive business practice. TI is not responsible or liable for any such statements.

TI products are not authorized for use in safety-critical applications (such as life support) where a failure of the TI product would reasonably be expected to cause severe personal injury or death, unless officers of the parties have executed an agreement specifically governing such use. Buyers represent that they have all necessary expertise in the safety and regulatory ramifications of their applications, and acknowledge and agree that they are solely responsible for all legal, regulatory and safety-related requirements concerning their products and any use of TI products in such safety-critical applications, notwithstanding any applications-related information or support that may be provided by TI. Further, Buyers must fully indemnify TI and its representatives against any damages arising out of the use of TI products in such safety-critical applications.

TI products are neither designed nor intended for use in military/aerospace applications or environments unless the TI products are specifically designated by TI as military-grade or "enhanced plastic." Only products designated by TI as military-grade meet military specifications. Buyers acknowledge and agree that any such use of TI products which TI has not designated as military-grade is solely at the Buyer's risk, and that they are solely responsible for compliance with all legal and regulatory requirements in connection with such use.

TI products are neither designed nor intended for use in automotive applications or environments unless the specific TI products are designated by TI as compliant with ISO/TS 16949 requirements. Buyers acknowledge and agree that, if they use any non-designated products in automotive applications, TI will not be responsible for any failure to meet such requirements.

Following are URLs where you can obtain information on other Texas Instruments products and application solutions:

<b>Products</b>		<b>Applications</b>	
Amplifiers	<a href="http://amplifier.ti.com">amplifier.ti.com</a>	Audio	<a href="http://www.ti.com/audio">www.ti.com/audio</a>
Data Converters	<a href="http://dataconverter.ti.com">dataconverter.ti.com</a>	Automotive	<a href="http://www.ti.com/automotive">www.ti.com/automotive</a>
DSP	<a href="http://dsp.ti.com">dsp.ti.com</a>	Broadband	<a href="http://www.ti.com/broadband">www.ti.com/broadband</a>
Interface	<a href="http://interface.ti.com">interface.ti.com</a>	Digital Control	<a href="http://www.ti.com/digitalcontrol">www.ti.com/digitalcontrol</a>
Logic	<a href="http://logic.ti.com">logic.ti.com</a>	Military	<a href="http://www.ti.com/military">www.ti.com/military</a>
Power Mgmt	<a href="http://power.ti.com">power.ti.com</a>	Optical Networking	<a href="http://www.ti.com/opticalnetwork">www.ti.com/opticalnetwork</a>
Microcontrollers	<a href="http://microcontroller.ti.com">microcontroller.ti.com</a>	Security	<a href="http://www.ti.com/security">www.ti.com/security</a>
RFID	<a href="http://www.ti-rfid.com">www.ti-rfid.com</a>	Telephony	<a href="http://www.ti.com/telephony">www.ti.com/telephony</a>
Low Power Wireless	<a href="http://www.ti.com/lpw">www.ti.com/lpw</a>	Video & Imaging	<a href="http://www.ti.com/video">www.ti.com/video</a>
		Wireless	<a href="http://www.ti.com/wireless">www.ti.com/wireless</a>

Mailing Address: Texas Instruments, Post Office Box 655303, Dallas, Texas 75265  
Copyright © 2007, Texas Instruments Incorporated