

1.0 SCOPE

This specification covers the detail requirements for a quad operational amplifier.

It is highly recommended that this data sheet be used as a baseline for new military or aerospace spec control drawings.

1.2 Part Number. The complete part numbers per Table I of this specification follow:

<u>Device</u>	<u>Part Number</u>	<u>Package</u>
A	OP-11AY/883	Y
B	OP-11BY/883	Y
C	OP-11CY/883	Y
A	OP-11ARC/883	RC

1.2.3 Case Outline.

<u>Letter</u>	<u>Case Outline (Lead finish per MIL-M-38510)</u>
Y	14-lead ceramic dual-in-line package (CERDIP)
RC	20-contact hermetic leadless chip carrier (LCC)

1.3 Absolute Maximum Ratings. ($T_A = 25^\circ\text{C}$, unless otherwise noted)

Supply Voltage.....	$\pm 22\text{V}$
Power Dissipation.....	800mW
Differential Input Voltage.....	$\pm 30\text{V}$
Input Voltage.....	Supply Voltage
Output Short-Circuit Duration.....	Continuous
Operating Temperature Range.....	-55°C to $+125^\circ\text{C}$
Storage Temperature Range.....	-65°C to $+150^\circ\text{C}$
Lead Temperature (Soldering, 60 sec).....	$+300^\circ\text{C}$

1.5 Thermal Characteristics:

Thermal Resistance, CERDIP (Y) package:

Junction-to-Case (θ_{JC}) = 29°C/W MAX

Junction-to-Ambient (θ_{JA}) = 91°C/W MAX

Thermal Resistance, LCC (RC) package:

Junction-to-Case (θ_{JC}) = 35°C/W MAX

Junction-to-Ambient (θ_{JA}) = 110°C/W MAX

OP-11

TABLE 1

$V_S = \pm 15V$; $R_S = 50\Omega$; $V_{CM} = 0V$; $T_A = 25^\circ C$ unless otherwise specified.

Characteristics	Symbol	Special Conditions	OP-11/883				Units
			LIMITS A		LIMITS B		
			Min	Max	Min	Max	
Input Offset Voltage	V_{OS}	$R_S \leq 10k\Omega$	--	0.5	--	2.5	mV
		$R_S \leq 10k\Omega$ $-55^\circ C \leq T_A \leq +125^\circ C$	--	1.0	--	3.5	mV
Input Offset Current	I_{OS}	$-55^\circ C \leq T_A \leq +125^\circ C$	--	20	--	50	nA
			--	40	--	80	nA
Input Bias Current	I_B	$-55^\circ C \leq T_A \leq +125^\circ C$	--	± 300	--	± 500	nA
			--	± 375	--	± 650	nA
Input Voltage Range (Note 1)	IVR	$-55^\circ C \leq T_A \leq +125^\circ C$	± 12	--	± 12	--	V
Common-Mode Rejection	CMR	$V_{CM} = IVR = \pm 12V$ $R_S \leq 10k\Omega$ $-55^\circ C \leq T_A \leq +125^\circ C$	100	--	100	--	dB
Power Supply Rejection Ratio	PSRR	$V_S = \pm 5V$ to $\pm 15V$ $R_S \leq 10k\Omega$ $-55^\circ C \leq T_A \leq +125^\circ C$	--	32	--	32	$\mu V/V$
Output Voltage Swing	V_O	$R_L \geq 2k\Omega$ $-55^\circ C \leq T_A \leq +125^\circ C$	± 11	--	± 11	--	V
Large-Signal Voltage Gain	A_{VO}	$V_O = \pm 10V, R_L \geq 2k\Omega$	100	--	100	--	V/mV
		$V_O = \pm 10V, R_L \geq 2k\Omega$ $-55^\circ C \leq T_A \leq +125^\circ C$	50	--	50	--	V/mV
Power Consumption (All 4 Amplifiers)	P_d	$V_O = 0V$	--	180	--	180	mW
		$V_O = 0V$ $-55^\circ C \leq T_A \leq +125^\circ C$	--	200	--	200	mW

TABLE 1 (Continued)

$V_S = \pm 15V$; $R_S = 50\Omega$; $V_{CM} = 0V$; $T_A = 25^\circ C$ unless otherwise specified.

Characteristics	Symbol	Special Conditions	OP-11/883				Units
			LIMITS A		LIMITS B		
			Min	Max	Min	Max	
Supply Current (All 4 Amplifiers)	I_{SY}	$V_O = 0V$	-	6	-	6	mA
		$V_O = 0V$ $-55^\circ C \leq T_A \leq +125^\circ C$	-	6.66	-	6.66	mA
Input Offset	ΔV_{OS}	$-55^\circ C \leq T_A \leq +125^\circ C$	-	0.75	-	2.0	mV
Voltage Match		$-55^\circ C \leq T_A \leq +125^\circ C$	-	1.0	-	2.5	mV
Common-Mode Rejection Match	ΔCMR	$V_{CM} = IVR = \pm 12V$ $-55^\circ C \leq T_A \leq +125^\circ C$	94	-	94	-	dB
Risetime	t_r	$A_{VCL} = +1, V_{IN} = 50mV$	-	145	-	145	ns
Overshoot	OS		-	25	-	25	%
Closed-Loop Bandwidth (Note 2)	BW	$A_{VCL} = +1$	2.4	-	2.4	-	MHz
Channel Separation	CS		100	-	100	-	dB
Input Resistance Differential Mode (Note 3)	R_{IN}		173	-	100	-	k Ω
Large-Signal Bandwidth (Note 4)	LSBW	$V_O = 20V_{p-p}$	11	-	11	-	kHz
Slew Rate	SR	$A_{VCL} = +1$	0.7	-	0.7	-	V/ μs

NOTES:

1. IVR is defined as the V_{CM} range used for the CMR test.
2. Bandwidth (BW) is derived from t_r by the relationship $BW = \frac{0.35}{t_r}$
3. R_{IN} is derived from I_B by the relationship $R_{IN} = \frac{2kT}{qI_B}$, where $\frac{kT}{q} = 0.026V @ +25^\circ C$
4. LSBW is derived from SR by the relationship $LSBW = \frac{SR}{2\pi V_{peak}}$

12
OPERATIONAL AMPLIFIERS

TABLE 1 (Continued)

$V_S = \pm 15V$; $R_S = 50\Omega$; $V_{CM} = 0V$; $T_A = 25^\circ C$ unless otherwise specified.

Characteristics	Symbol	Special Conditions	OP-11/883		Units
			LIMITS C		
			Min	Max	
Input Offset Voltage	V_{OS}	$R_S \leq 10k\Omega$	--	5	mV
		$R_S \leq 10k\Omega$ $-55^\circ C \leq T_A \leq +125^\circ C$	--	6	mV
Input Offset Current	I_{OS}	$-55^\circ C \leq T_A \leq +125^\circ C$	--	200	nA
			--	300	nA
Input Bias Current	I_B	$-55^\circ C \leq T_A \leq +125^\circ C$	--	± 500	nA
			--	± 800	nA
Input Voltage Range (Note 1)	IVR	$-55^\circ C \leq T_A \leq +125^\circ C$	± 12	--	V
Common-Mode Rejection	CMR	$V_{CM} = IVR = \pm 12V$ $R_S \leq 10k\Omega$ $-55^\circ C \leq T_A \leq +125^\circ C$	70	--	dB
Power Supply Rejection Ratio	PSRR	$V_S = \pm 5V$ to $\pm 15V$ $R_S \leq 10k\Omega$ $-55^\circ C \leq T_A \leq +125^\circ C$	--	100	$\mu V/V$
Output Voltage Swing	V_O	$R_L \geq 2k\Omega$ $-55^\circ C \leq T_A \leq +125^\circ C$	± 11	--	V
Large-Signal Voltage Gain	A_{VO}	$V_O = \pm 10V$, $R_L \geq 2k\Omega$	50	--	V/mV
		$V_O = \pm 10V$, $R_L \geq 2k\Omega$ $-55^\circ C \leq T_A \leq +125^\circ C$	25	--	V/mV
Power Consumption (All 4 Amplifiers)	P_d	$V_O = 0V$	--	340	mW
		$V_O = 0V$ $-55^\circ C \leq T_A \leq +125^\circ C$	--	400	mW

TABLE 1 (Continued)

$V_S = \pm 15V$; $R_S = 50\Omega$; $V_{CM} = 0V$; $T_A = 25^\circ C$ unless otherwise specified.

Characteristics	Symbol	Special Conditions	OP-11/883		Units
			LIMITS C		
			Min	Max	
Supply Current (All 4 Amplifiers)	I_{SY}	$V_O = 0V$	--	11.33	mA
		$V_O = 0V$ $-55^\circ C \leq T_A \leq +125^\circ C$	--	13.33	mA
Risetime	t_r	$A_{VCL} = +1, V_{IN} = 50mV$	--	145	ns
Overshoot	OS		--	25	%
Closed-Loop Bandwidth (Note 2)	BW	$A_{VCL} = +1$	2.4	--	MHz
Input Resistance Differential Mode (Note 3)	R_{IN}		100	--	k Ω
Large-Signal Bandwidth (Note 4)	LSBW	$V_O = 20V_{p-p}$	11	--	kHz
Slew Rate	SR	$A_{VCL} = +1$	0.7	--	V/ μs

NOTES:

1. IVR is defined as the V_{CM} range used for the CMR test.
2. Bandwidth (BW) is derived from t_r by the relationship $BW = \frac{0.35}{t_r}$
3. R_{IN} is derived from I_B by the relationship $R_{IN} = \frac{2kT}{qI_B}$, where $\frac{kT}{q} = 0.026V @ +25^\circ C$
4. LSBW is derived from SR by the relationship $LSBW = \frac{SR}{2\pi V_{peak}}$

TABLE 2

OP-11/883

Electrical Test Requirements For Class B Devices

MIL-STD-883 Test Requirements	Subgroups (see Table 3)
Interim Electrical Parameters (pre Burn-In)	1
Final Electrical Test Parameters	1*, 2, 3, 4, 5, 6
Group A Test Requirements	1, 2, 3, 4, 5, 6, 9

* PDA applies to Subgroup 1 only.
No other Subgroups are included in PDA.

TABLE 3

Group A Inspection

$V_S = \pm 15V$; $R_S = 50\Omega$; $V_{CM} = 0V$; $T_A = T_J$ unless otherwise specified.

Subgroup	Symbol	Special Conditions	OP-11/883				Units
			LIMITS A		LIMITS B		
			Min	Max	Min	Max	
Subgroup 1 $T_A = +25^\circ C$	V_{OS}	$R_S = 50\Omega, 10k\Omega$	-	0.5	-	2.5	mV
	I_{OS}		-	20	-	50	nA
	I_B		-	± 300	-	± 500	nA
	CMR	$V_{CM} = \pm 12V$; $R_S = 50\Omega, 10k\Omega$	100	-	100	-	dB
	PSRR	$V_S = \pm 5V, \pm 15V$ $R_S = 50\Omega, 10k\Omega$	-	32	-	32	$\mu V/V$
	P_d	$V_O = 0V$	-	180	-	180	mW
	ΔV_{OS}		-	0.75	-	2.0	mV
	ΔCMR	$V_{CM} = \pm 12V$	94	-	94	-	dB
Subgroup 2 $T_A = +125^\circ C$	V_{OS}	$R_S = 50\Omega, 10k\Omega$	-	1	-	3.5	mV
	I_{OS}		-	40	-	80	nA
	I_B		-	± 375	-	± 650	nA
	CMR	$V_{CM} = \pm 12V$; $R_S = 50\Omega, 10k\Omega$	100	-	100	-	dB
	PSRR	$V_S = \pm 5V, \pm 15V$ $R_S = 50\Omega, 10k\Omega$	-	32	-	32	$\mu V/V$
	P_d	$V_O = 0V$	-	200	-	200	mW
	ΔV_{OS}		-	1	-	2.5	mV
	ΔCMR	$V_{CM} = \pm 12V$	94	-	94	-	dB
Subgroup 3 $T_A = -55^\circ C$	All Tests, Limits and Conditions are the same as for Subgroup 2.						

OPERATIONAL AMPLIFIERS 12

TABLE 3

Group A Inspection (Continued)

$V_S = \pm 15V$; $R_S = 50\Omega$; $V_{CM} = 0V$; $T_A = T_J$ unless otherwise specified.

Subgroup	Symbol	Special Conditions	OP-11/883				Units
			LIMITS A		LIMITS B		
			Min	Max	Min	Max	
Subgroup 4	V_O	$R_L = 2k\Omega$	± 11	-	± 11	-	V
$T_A = +25^\circ C$	A_{VO}	$V_O = \pm 10V, R_L = 2k\Omega$	100	-	100	-	V/mV
	CS		100	-	100	-	dB
Subgroup 5	V_O	$R_L = 2k\Omega$	± 11	-	± 11	-	V
$T_A = +125^\circ C$	A_{VO}	$V_O = \pm 10V, R_L = 2k\Omega$	50	-	50	-	V/mV
Subgroup 6 $T_A = -55^\circ C$	All Tests, Limits and Conditions are the same as for Subgroup 5.						
Subgroup 9	SR	$A_{VCL} = +1$	0.7	-	0.7	-	V/ μs
$T_A = +25^\circ C$	t_r	$A_{VCL} = +1, V_{IN} = 50mV$	-	145	-	145	ns
	OS		-	25	-	25	%

TABLE 3

Group A Inspection (Continued)

$V_S = \pm 15V$; $R_S = 50\Omega$; $V_{CM} = 0V$; $T_A = T_J$ unless otherwise specified.

Subgroup	Symbol	Special Conditions	OP-11/883 LIMITS C		Units
			Min	Max	
Subgroup 1 $T_A = +25^\circ C$	V_{OS}	$R_S = 50\Omega, 10k\Omega$	--	5	mV
	I_{OS}		--	200	nA
	I_B		--	± 500	nA
	CMR	$V_{CM} = \pm 12V$; $R_S = 50\Omega, 10k\Omega$	70	--	dB
	PSRR	$V_S = \pm 5V, \pm 15V$ $R_S = 50\Omega, 10k\Omega$	--	100	$\mu V/V$
	P_d	$V_O = 0V$	--	340	mW
Subgroup 2 $T_A = +125^\circ C$	V_{OS}	$R_S = 50\Omega, 10k\Omega$	--	6	mV
	I_{OS}		--	300	nA
	I_B		--	± 800	nA
	CMR	$V_{CM} = \pm 12V$; $R_S = 50\Omega, 10k\Omega$	70	--	dB
	PSRR	$V_S = \pm 5V, \pm 15V$ $R_S = 50\Omega, 10k\Omega$	--	100	$\mu V/V$
	P_d	$V_O = 0V$	--	400	mW
Subgroup 3 $T_A = -55^\circ C$	All Tests, Limits and Conditions are the same as for Subgroup 2.				
Subgroup 4 $T_A = +25^\circ C$	V_O	$R_L = 2k\Omega$	± 11	--	V
	A_{VO}	$V_O = \pm 10V, R_L = 2k\Omega$	50	--	V/mV

OP-11

TABLE 3

Group A Inspection (Continued)

$V_S = \pm 15V$; $R_S = 50\Omega$; $V_{CM} = 0V$; $T_A = T_J$ unless otherwise specified.

Subgroup	Symbol	Special Conditions	OP-11/883 LIMITS C		Units
			Min	Max	
Subgroup 5	V_O	$R_L = 2k\Omega$	± 11	–	V
$T_A = +125^\circ C$	A_{VO}	$V_O = \pm 10V, R_L = 2k\Omega$	25	–	V/mV
Subgroup 6 $T_A = -55^\circ C$	All Tests, Limits and Conditions are the same as for Subgroup 5.				
Subgroup 9	SR	$A_{VCL} = +1$	0.7	–	V/ μs
$T_A = +25^\circ C$	t_r	$A_{VCL} = +1, V_{IN} = 50mV$	–	145	ns
	OS		–	25	%

3.2.1 Simplified Schematic and Pin Connections.

(One of Four Amplifiers Shown)

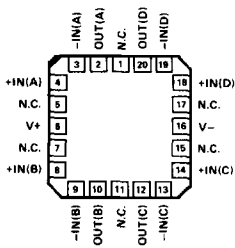
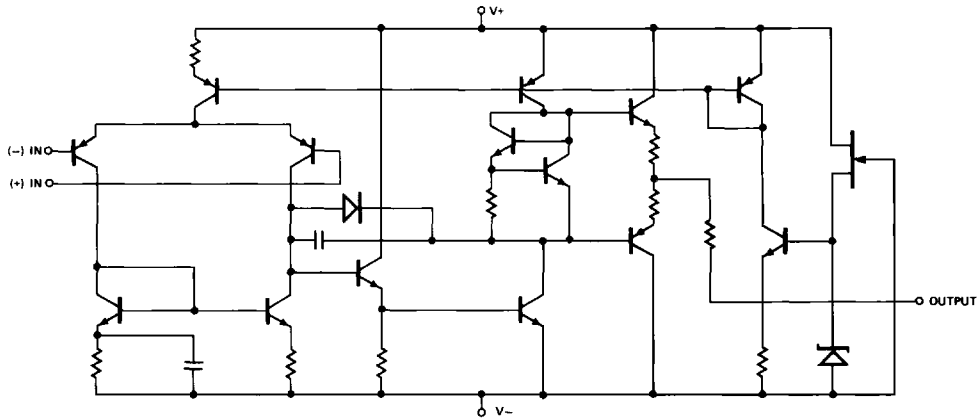

**OP-11ARC/883
LCC
(RC-Suffix)**

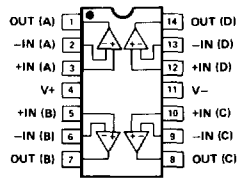

**14-PIN HERMETIC DIP
(Y-Suffix)**

3.2.4 Microcircuit Group Assignment. This microcircuit is covered by microcircuit group 49.

4.2 Life Test/Burn-In Circuit.

