

## Monolithic bus driver with ISO 9141 interface

### Features

- Operating power supply voltage range  
 $4.5\text{ V} \leq V_S \leq 36\text{ V}$  (40 V for transients)
- Reverse supply (battery) protected down to  
 $V_S \geq -24\text{ V}$
- Standby mode with very low current consumption  
 $I_{S_{SB}} \leq 1\text{ mA}$  @  $V_{CC} \leq 0.5\text{ V}$
- Low quiescent current in off condition  
 $I_{S_{OFF}} = 120\text{ }\mu\text{A}$
- TTL compatible TX input
- Bidirectional K-I/O pin with supply voltage dependent input threshold
- Overtemperature shut down function Selective to K-I/O pin
- Wide input and output voltage range  
 $-24\text{ V} \leq V_K \leq V_S$
- K output current limitation, typ.  $I_K = 60\text{ mA}$
- Defined OFF output status in undervoltage condition and  $V_S$  or GND interruption
- Controlled output slope for low EMI

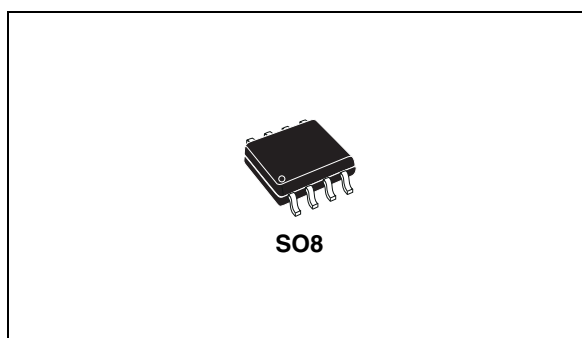

- High input impedance for open  $V_S$  or GND connection
- Defined output ON status of LO or RX for open LI or K inputs
- Defined K output OFF for TX input open
- Integrated pull up resistors for TX, RX and LO
- EMI robustness optimized

### Description

The L9637 is a monolithic integrated circuit containing standard ISO 9141 compatible interface functions.

**Table 1. Device summary**

Order code	Package	Packing
L9637D	SO8	Tube
L9637D013TR	SO8	Tape and reel
E-L9637D <sup>(1)</sup>	SO8	Tube
E-L9637D013TR <sup>(1)</sup>	SO8	Tape and reel

1. Device in ECOPACK® package (see [Section 4: Package information on page 13](#)).

---

# Contents

<b>1</b>	<b>Block diagram and pin description</b> .....	<b>3</b>
1.1	Block diagram .....	3
1.2	Pin description .....	3
<b>2</b>	<b>Electrical specification</b> .....	<b>4</b>
2.1	Absolute maximum ratings .....	4
2.2	Thermal data .....	4
2.3	Electrical characteristics .....	4
<b>3</b>	<b>Functional description</b> .....	<b>9</b>
<b>4</b>	<b>Package information</b> .....	<b>13</b>
<b>5</b>	<b>Revision history</b> .....	<b>14</b>

# 1 Block diagram and pin description

## 1.1 Block diagram

Figure 1. Block diagram

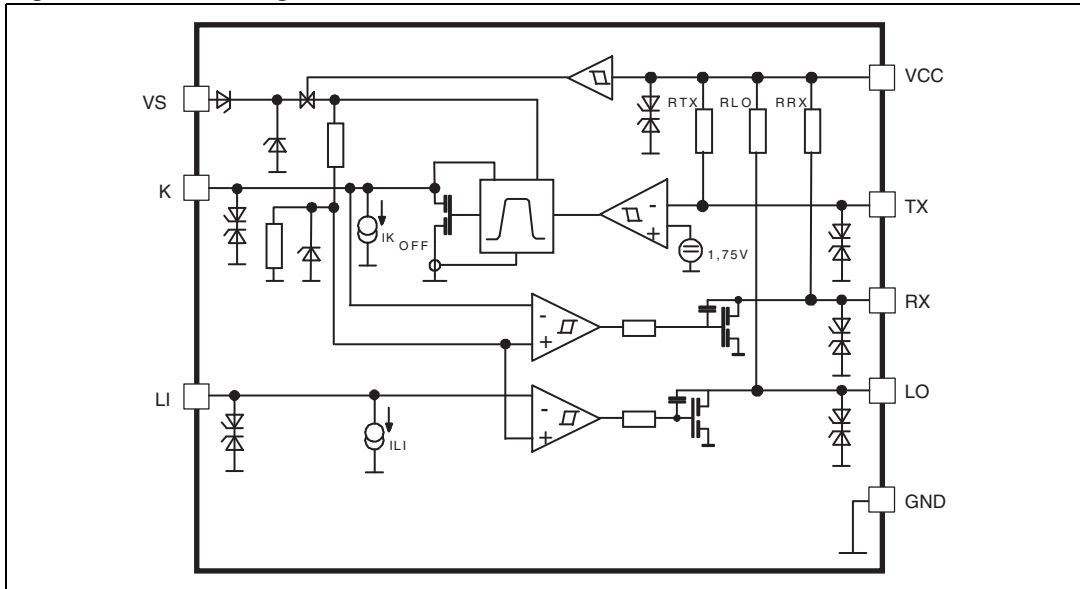

## 1.2 Pin description

Figure 2. Pin connection (top view)

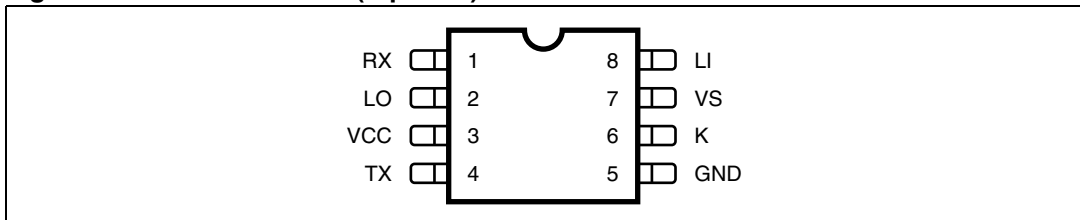

Table 2. Pin description

N.	Name	Function
1	RX	Output for K as input
2	LO	Output L comparator
3	VCC	Stabilized voltage supply
4	TX	Input for K as output
5	GND	Common GND
6	K	Bidirectional I/O
7	VS	Supply voltage
8	LI	Input L comparator

## 2 Electrical specification

### 2.1 Absolute maximum ratings

**Table 3. Absolute maximum ratings (No damage or latch)**

Symbol	Parameter	Value	Unit
$V_S$	Supply voltage ISO transients $t = 400$ ms	-24 to +36 -24 to +40	V
$V_{CC}$	Stabilized voltage	-0.3 to +7	V
$\Delta V_S/d_t$	Supply voltage transient	-10 to +10	V/ $\mu$ s
$V_{LI, K}$	Pin voltage	-24 to $V_S$	V
$V_{LO, RX, TX}$		-24 to $V_{CC}$	V

*Note:* Max. ESD voltages are  $\pm 2$ kV with human body model  $C = 100$ pF,  $R = 1.5$ k corresponds to maximum energy dissipation 0.2mJ according to MIL883C.

### 2.2 Thermal data

**Table 4. Thermal data**

Symbol	Parameter	Min.	Typ.	Max.	Unit
$T_{JSDon}$	Temperature K shutdown switch on threshold	160	-	200	$^{\circ}$ C
$T_{JSDoff}$	Temperature K shutdown switch off threshold	150	-	200	$^{\circ}$ C
$R_{th j-amb}$	Thermal steady state junction to ambient resistance	130	155	180	$^{\circ}$ C/W

### 2.3 Electrical characteristics

The electrical characteristics are valid within the below defined operating conditions, unless otherwise specified. The function is guaranteed by design until  $T_{JSDon}$  temperature shutdown switch-on-threshold.

**Table 5. Electrical characteristics**

Symbol	Parameter	Test condition	Min.	Typ.	Max.	Unit
$V_S$	Supply voltage	-	4.5	-	36	V
$V_{CC}$	Stabilized voltage	see note <sup>(1)</sup>	3	5	7	V
$T_j$	Junction temperature	-	-40	-	150	$^{\circ}$ C
$I_{CC}$	Supply $V_{CC}$ current	$V_{CC} \leq 5.5$ V; $V_{LI}, V_{TX} = 0$ V	-	1.4	2.3	mA
		$V_K \geq V_{K_{high}}$ ; $V_{LI} \geq V_{LI_{high}}$ $V_{TX} = V_{CC}$ @ $V_{CC} \leq 5.5$ V	-5	<1	5	$\mu$ A

Table 5. Electrical characteristics (continued)

Symbol	Parameter	Test condition	Min.	Typ.	Max.	Unit
IS <sub>ON</sub>	Supply V <sub>S</sub> current	V <sub>S</sub> ≤ 16 V; VLI, VTX = 0 V	-	1.2	3	mA
IS <sub>OFF</sub>		VK ≥ VK <sub>high</sub> ; VLI ≥ VLI <sub>high</sub> VTX ≥ VTX <sub>high</sub> @ V <sub>S</sub> ≤ 12 V	-	120	220	μA
IS <sub>SB</sub>		V <sub>CC</sub> ≤ 0.5 V @ V <sub>S</sub> ≤ 12 V	-	<1	-	μA
VK <sub>low</sub>	Input voltage low state	RX output status LOW 4.5 V ≤ V <sub>S</sub> ≤ 18 V	-24	-	0.45V <sub>S</sub>	V
		RX output status LOW 18 V < V <sub>S</sub>	-24	-	8	V
VK <sub>high</sub>	Input voltage high state	RX output status HIGH 4.5 V ≤ V <sub>S</sub> ≤ 18 V	0.55V <sub>S</sub>	-	V <sub>S</sub>	V
		RX output status HIGH 18 V < V <sub>S</sub>	12	-	V <sub>S</sub>	V
V <sub>Khys</sub>	Input threshold hysteresis	VK <sub>high</sub> - VK <sub>low</sub>	-	0.025 V <sub>S</sub>	0.8	V
I <sub>Koff</sub>	Input current	@ VTX ≥ VTX <sub>high</sub> VK ≤ V <sub>S</sub> ; V <sub>S</sub> , V <sub>CC</sub> ≥ 0 or V <sub>S</sub> , V <sub>CC</sub> = open	-5	4	25	μA
RK <sub>ON</sub>	Output ON impedance	@ V <sub>S</sub> ≥ 6.5 V VTX ≤ VTX <sub>low</sub> I <sub>K</sub> ≥ 7 mA <sup>(2)</sup>	-	10	30	Ω
IK <sub>SC</sub>	Short circuit current		30	60	100	mA
VTX <sub>low</sub>	Input voltage LOW state		-24	-	1	V
VTX <sub>high</sub>	Input voltage HIGH state		2.5	-	V <sub>CC</sub>	V
RRX <sub>ON</sub> RLO <sub>ON</sub>	Output ON impedance	VK ≤ VK <sub>low</sub> ; VLI ≤ VLI <sub>low</sub> V <sub>S</sub> ≥ 6.5 V I <sub>RX, LO</sub> ≥ 1 mA	-	40	90	Ω
IRX <sub>SC</sub> ILO <sub>SC</sub>	Output short circuit current		9	20	35	mA
VRX <sub>H</sub> VLO <sub>H</sub>	Output voltage HIGH state	10MΩ ≤ R <sub>LRX</sub> 10MΩ ≤ R <sub>LLO</sub>	V <sub>CC</sub> - 0.25	V <sub>CC</sub> - 0.1	V <sub>CC</sub> -	V
RLO RRX	Output pull-up resistance	Output status = (HIGH) -0.15 V ≤ VLO ≤ V <sub>CC</sub> + 0.15 V -0.15 V ≤ VRX ≤ V <sub>CC</sub> + 0.15 V	5	10	20	kΩ
RTX	Input pull up resistance	-0.15 V ≤ VTX ≤ V <sub>CC</sub> + 0.15 V	10	20	40	kΩ
VLI <sub>low</sub>	Input voltage LOW state	LO output status LOW 4.5 V ≤ V <sub>S</sub> ≤ 18 V	-24	-	0.45V <sub>S</sub>	V
		LO output status LOW 18 V < V <sub>S</sub>	-24	-	8	V

Table 5. Electrical characteristics (continued)

Symbol	Parameter	Test condition	Min.	Typ.	Max.	Unit
$V_{L_{high}}$	Input voltage HIGH state	LO output status HIGH $4.5\text{ V} \leq V_S \leq 18\text{ V}$ LO output status HIGH $18\text{ V} < V_S$	$0.55V_S$ 12	-	$V_S$	V
$V_{L_{hys}}$	Input threshold hysteresis	$V_{L_{high}} - V_{L_{low}}$	-	$0.025V_S$	0.8	V
ILI	Input current	$V_{LI} \leq V_S$ , $V_S$ , $V_{CC} \geq 0$ or $V_S$ , $V_{CC} = \text{open}$	-5	4	25	$\mu\text{A}$
$C_{K_{i,LO,RX}}$	Internal output capacities		-	-	20	pF
$f_{LI-LO}$ $f_{K-RX}$ $f_{TX-K}$	Transmission frequency	$9\text{ V} < V_S < 16\text{ V}$ (external loads) $R_{KO} = 510\ \Omega$ , $C_K \leq 1.3\text{ nF}$ in active mode see <a href="#">Figure 5</a>	-	-	50	kHz
$t_{rLI-LO}$ $t_{rK-RX}$ $t_{rTX-K}$	Rise time	for the definition of $t_r$ , $t_f$ see <a href="#">Figure 3</a>	-	2	6	$\mu\text{s}$
$t_{fLI-LO}$ $t_{fK-RX}$ $t_{fTX-K}$	Fall time	$9\text{ V} < V_S < 16\text{ V}$ (external loads) $R_{KO} = 510\ \Omega$ , $C_K \leq 1.3\text{ nF}$	-	2	6	$\mu\text{s}$
$t_{OFF,LI-LO}$ $t_{OFF,K-RX}$ $t_{OFF,TX-K}$	Switch OFF time	for the definition of $t_{on}$ , $t_{OFF}$ see <a href="#">Figure 3</a> .	-	4	17	$\mu\text{s}$
$t_{ON,LI-LO}$ $t_{ON,K-RX}$ $t_{ON,TX-K}$	Switch ON time	$9\text{ V} < V_S < 16\text{ V}$ (external loads) $R_{KO} = 510\ \Omega$ , $C_K \leq 1.3\text{ nF}$ (inactive mode see <a href="#">Figure 5</a> )	-	4	17	$\mu\text{s}$

1. Specs are tested at 5V only. Compliance on Vcc full range is guaranteed by design.
2. For output currents lower than this value a series protection diode can become active. See also [Figure 8](#) and [9](#).

Figure 3. Input to output timings and output pulse shape

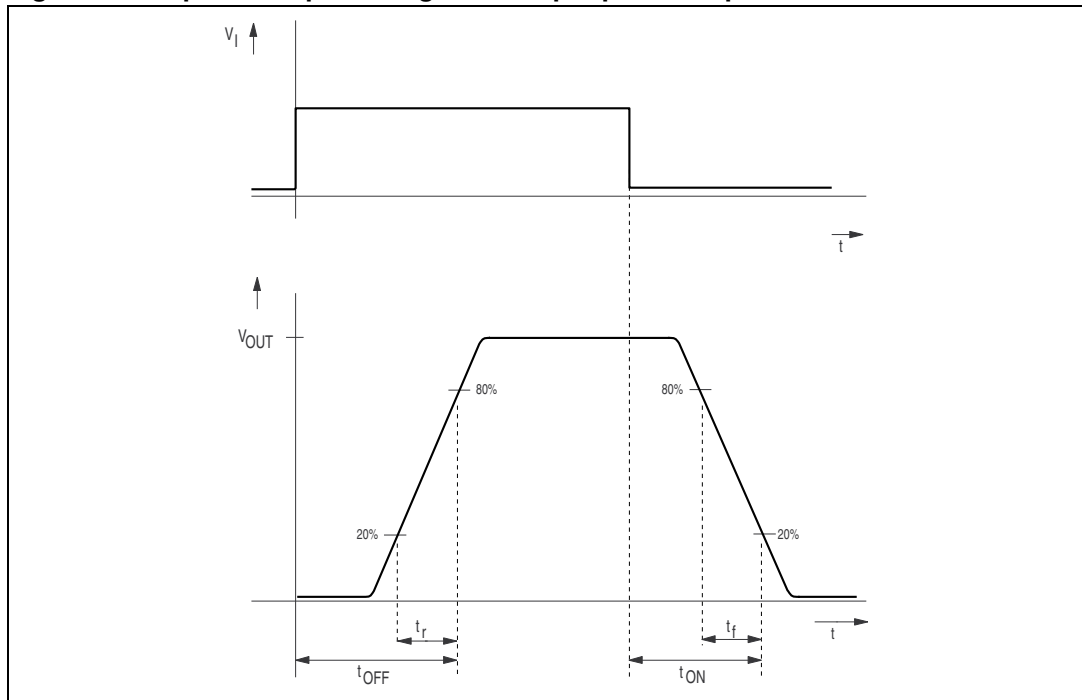
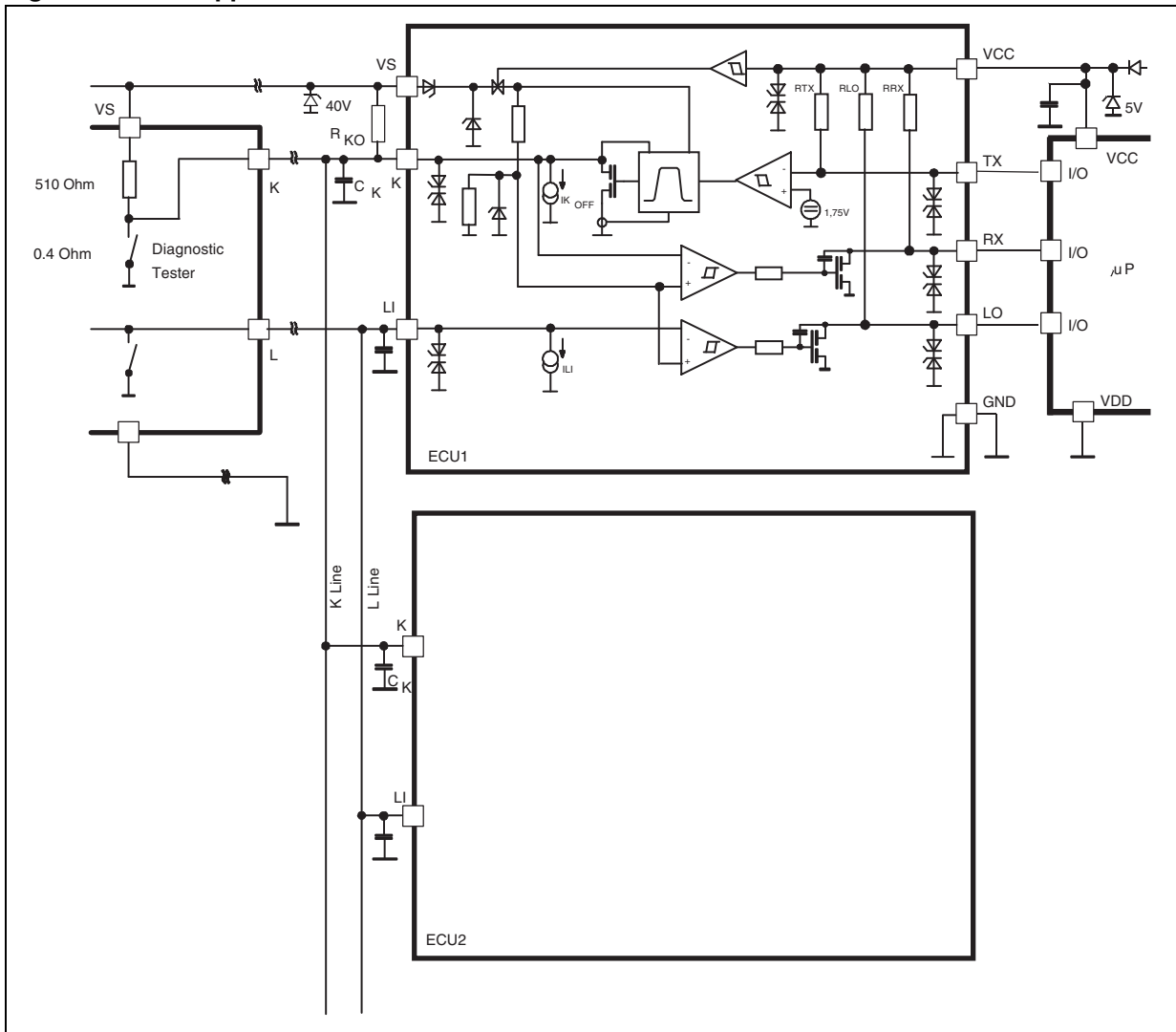

Figure 4. ISO application circuit





### 3 Functional description

The L9637 is a monolithic bus driver designed to provide bidirectional serial communication in automotive diagnostic applications according to the specification "Diagnostic Systems ISO9141".

The device provides a bidirectional link, called K, to the  $V_{Bat}$  related diagnosis bus. It also includes a separate comparator L which is also able to be linked to the  $V_{Bat}$  bus. The input TX and output RX of K are related to  $V_{CC}$  with her integrated pull up resistances. Also the L comparator output LO has a pull up resistance connected to  $V_{CC}$ .

The maximum external pull up resistance at K related to  $V_S$  should not be higher than  $R_{KO} \leq 5 \text{ k}\Omega$  to achieve clear output ON conditions.

All  $V_{Bat}$  bus defined inputs LI and K have supply voltage dependent thresholds together with sufficient hysteresis to suppress line spikes. These pins are protected against overvoltages, shorts to GND and  $V_S$  and can also be driven beyond  $V_S$  and GND.

These features are also given for TX, RX and LI only taking into account the behavior of the internal pull up resistances. The thermal shut down function switches OFF the K output if the chip temperature increases above the thermal shut down threshold. To reactivate K again the temperature must decrease below the K switch ON temp. To achieve no fault for  $V_S$  undervoltage conditions the outputs will be switched OFF and stay at high impedance.

The device is also protected against reverse battery condition. During lack of  $V_S$  or GND all pins shows high impedance characteristic. To realize a lack of the  $V_S$  related bus line LI and K the outputs LO and RX shows defined ON status.

Suppressing all 4 classes of "Schaffner" signals all pins can be load with short energy pulses of max.  $\pm 0.2 \text{ mJ}$ . All these features together with a high possible baud rate  $> 50 \text{ Kbaud}$ , controlled output slopes for low EMI, a wide power supply voltage range and a very small quiescent current during OFF (TX LI K=High) condition  $I_{S_{off}} \text{ typ} \leq 120 \mu\text{A}$ , and a real standby function with zero power consumption  $I_{S_{SB}} \text{ typ} \leq 1 \mu\text{A}$  during system de powering  $V_{CC} \leq 0.5 \text{ V}$  make this device high efficient for automotive bus system.

After wake up of the system from OFF or SB condition the first output signal will have an additional delay time  $t_{d_{typ}} \leq 5 \mu\text{s}$  see also [Figure 5](#).

The typical output voltage behavior for the K, LO, RX outputs as a function of the output current is shown in [Figure 6](#). [Figure 7](#) shows a waveform of the output signal when the low level changes from  $R_{ON} * I_{OUT}$  to  $I_{OUT} * 2 * R_{ON} + U_{BE}$  state. This variation occurs due to too low output current or after a negative transient forced to the output or to the supply voltage line.

Figure 5. Typical timing for mode transitions

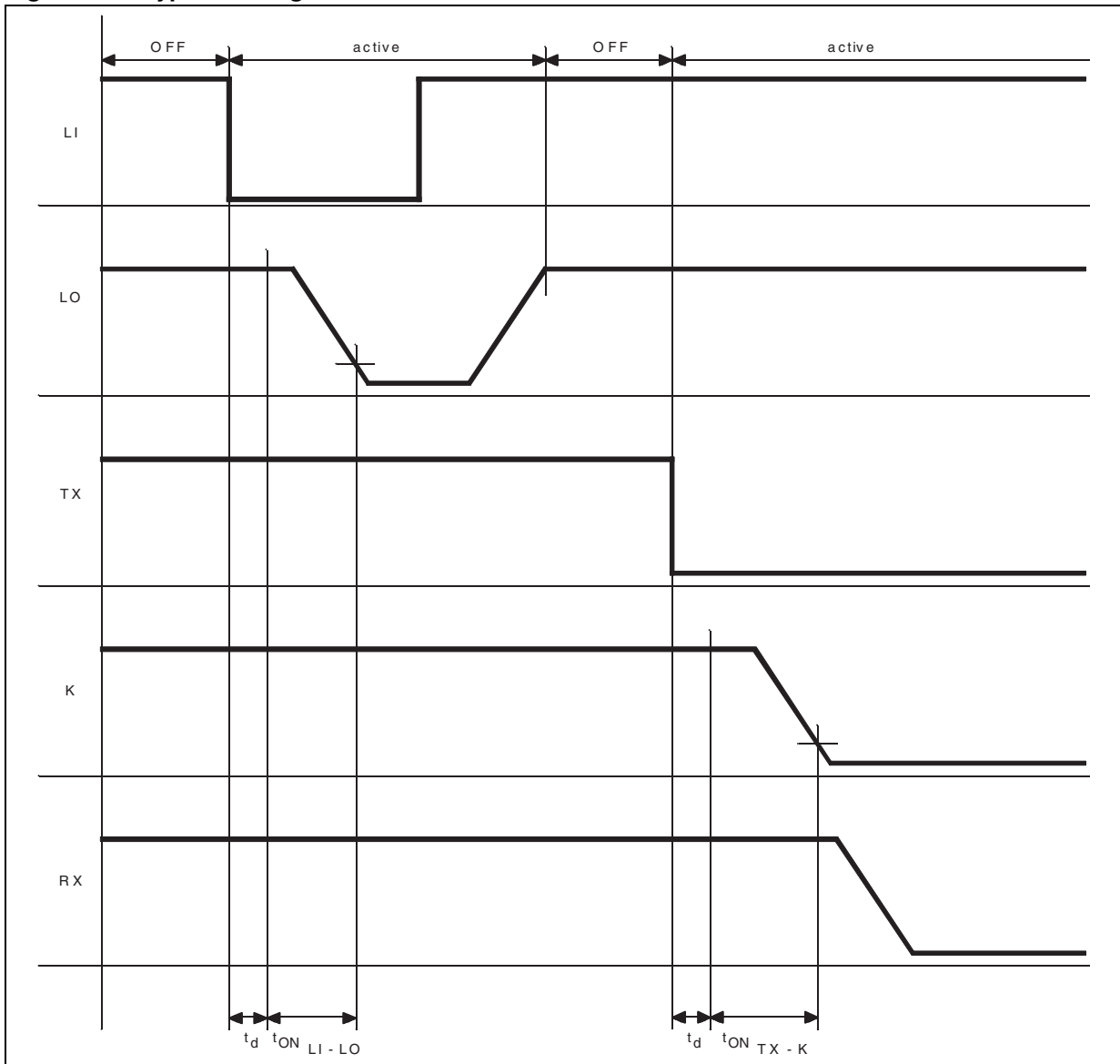

Figure 6. Output characteristics at K, LO, RX

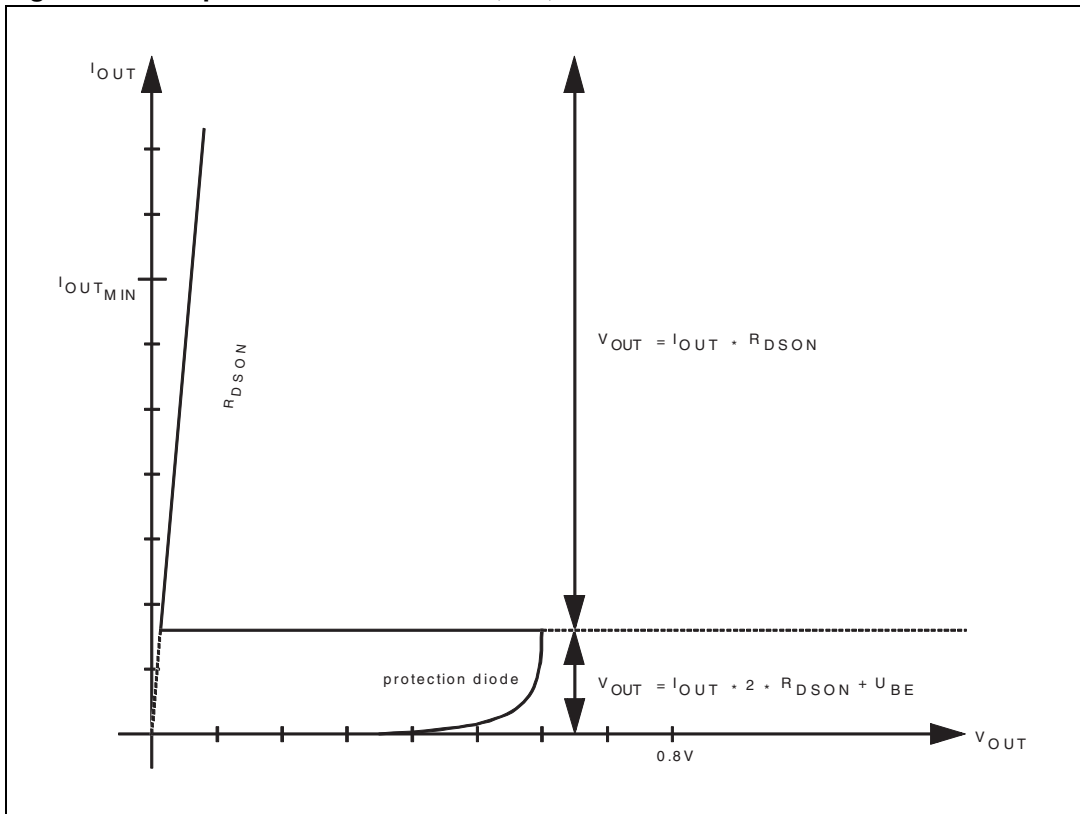

Figure 7. Output signal shape related to output current

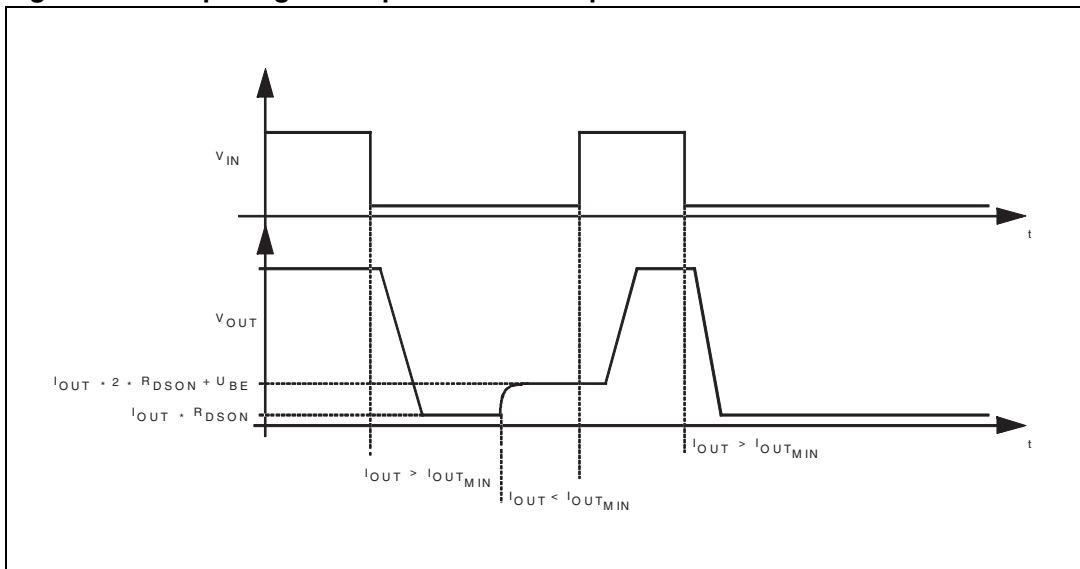

Figure 8. EMS performance (ISO 9141 bus system)

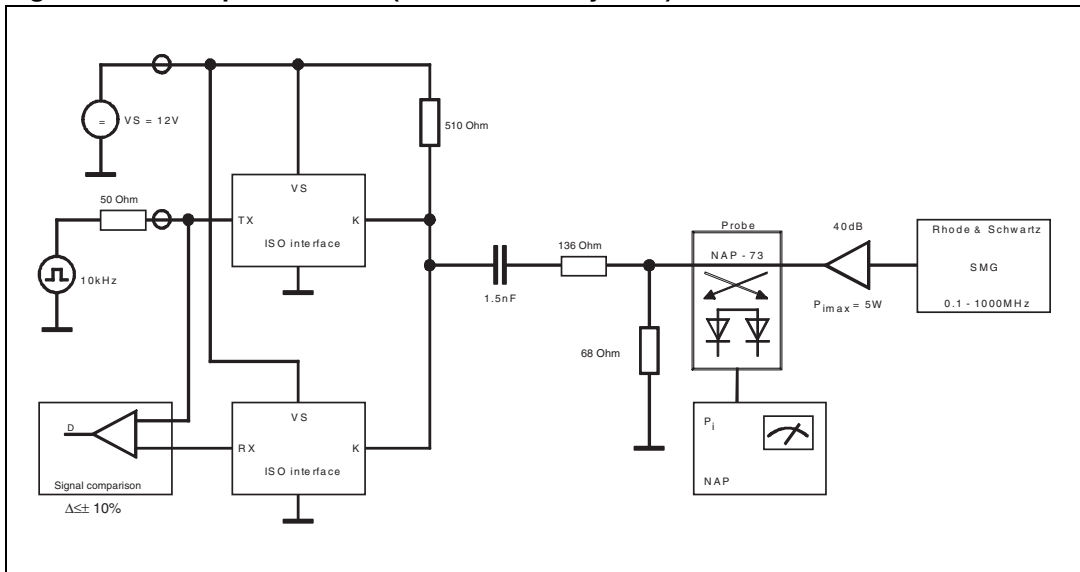
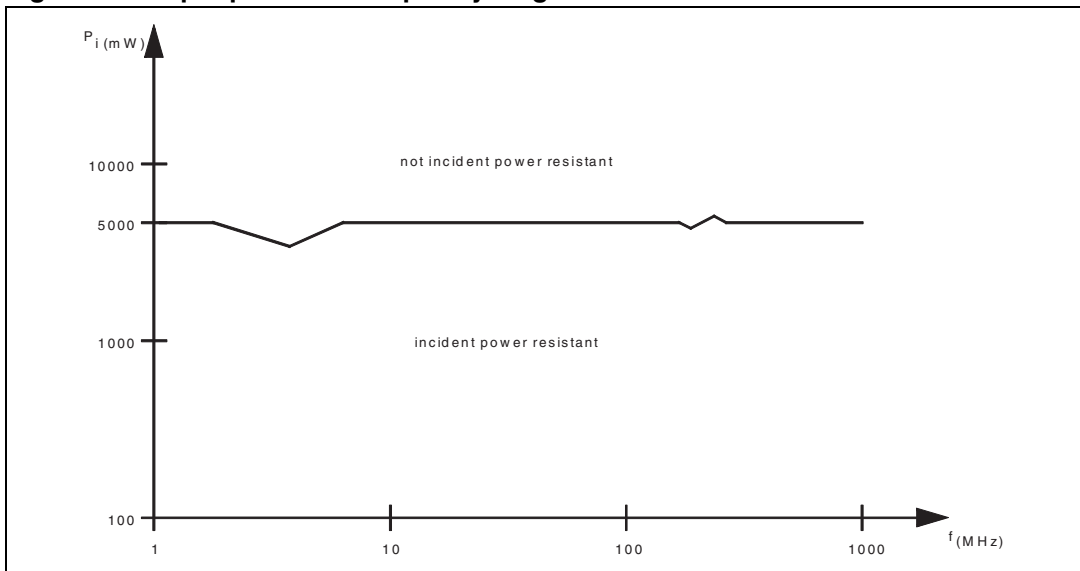

Figure 9. Input power vs. frequency diagram



# 4 Package information

In order to meet environmental requirements, ST offers these devices in different grades of ECOPACK® packages, depending on their level of environmental compliance. ECOPACK® specifications, grade definitions and product status are available at: [www.st.com](http://www.st.com).

ECOPACK® is an ST trademark.

**Figure 10. SO8 mechanical data and package dimensions**

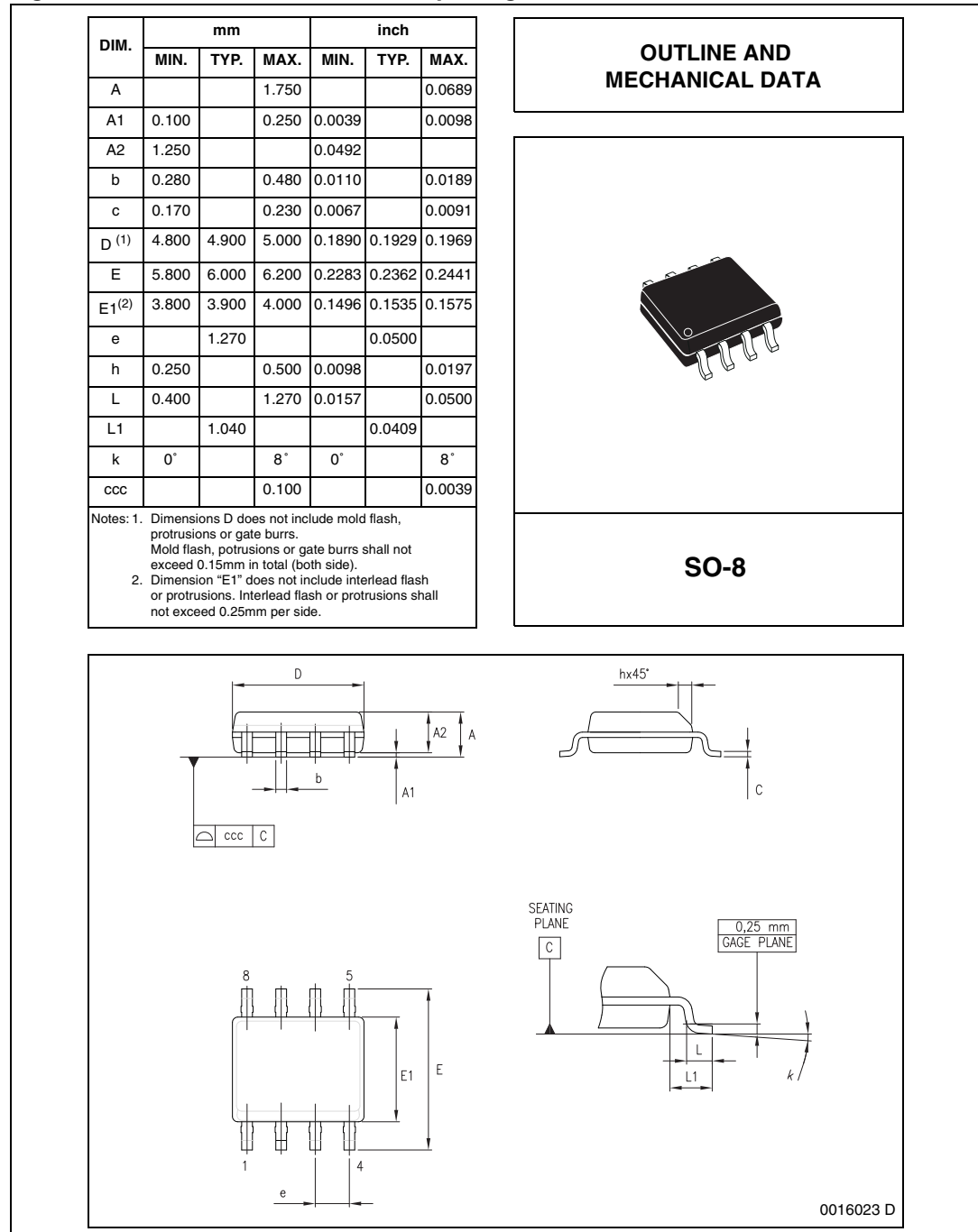

## 5 Revision history

**Table 6. Document revision history**

Date	Revision	Changes
24-Jan-2002	5	Initial release.
07-Nov-2008	6	Document reformatted. Added <a href="#">Table 1: Device summary on page 1</a> . Updated <a href="#">Section 4: Package information on page 13</a> .
15-Jun-2009	7	Updated the values of “stabilized voltage” and “transmission frequency” parameters on <a href="#">Table 5: Electrical characteristics</a> .
20-Sep-2013	8	Updated disclaimer.

**Please Read Carefully:**

Information in this document is provided solely in connection with ST products. STMicroelectronics NV and its subsidiaries ("ST") reserve the right to make changes, corrections, modifications or improvements, to this document, and the products and services described herein at any time, without notice.

All ST products are sold pursuant to ST's terms and conditions of sale.

Purchasers are solely responsible for the choice, selection and use of the ST products and services described herein, and ST assumes no liability whatsoever relating to the choice, selection or use of the ST products and services described herein.

No license, express or implied, by estoppel or otherwise, to any intellectual property rights is granted under this document. If any part of this document refers to any third party products or services it shall not be deemed a license grant by ST for the use of such third party products or services, or any intellectual property contained therein or considered as a warranty covering the use in any manner whatsoever of such third party products or services or any intellectual property contained therein.

**UNLESS OTHERWISE SET FORTH IN ST'S TERMS AND CONDITIONS OF SALE ST DISCLAIMS ANY EXPRESS OR IMPLIED WARRANTY WITH RESPECT TO THE USE AND/OR SALE OF ST PRODUCTS INCLUDING WITHOUT LIMITATION IMPLIED WARRANTIES OF MERCHANTABILITY, FITNESS FOR A PARTICULAR PURPOSE (AND THEIR EQUIVALENTS UNDER THE LAWS OF ANY JURISDICTION), OR INFRINGEMENT OF ANY PATENT, COPYRIGHT OR OTHER INTELLECTUAL PROPERTY RIGHT.**

**ST PRODUCTS ARE NOT DESIGNED OR AUTHORIZED FOR USE IN: (A) SAFETY CRITICAL APPLICATIONS SUCH AS LIFE SUPPORTING, ACTIVE IMPLANTED DEVICES OR SYSTEMS WITH PRODUCT FUNCTIONAL SAFETY REQUIREMENTS; (B) AERONAUTIC APPLICATIONS; (C) AUTOMOTIVE APPLICATIONS OR ENVIRONMENTS, AND/OR (D) AEROSPACE APPLICATIONS OR ENVIRONMENTS. WHERE ST PRODUCTS ARE NOT DESIGNED FOR SUCH USE, THE PURCHASER SHALL USE PRODUCTS AT PURCHASER'S SOLE RISK, EVEN IF ST HAS BEEN INFORMED IN WRITING OF SUCH USAGE, UNLESS A PRODUCT IS EXPRESSLY DESIGNATED BY ST AS BEING INTENDED FOR "AUTOMOTIVE, AUTOMOTIVE SAFETY OR MEDICAL" INDUSTRY DOMAINS ACCORDING TO ST PRODUCT DESIGN SPECIFICATIONS. PRODUCTS FORMALLY ESCC, QML OR JAN QUALIFIED ARE DEEMED SUITABLE FOR USE IN AEROSPACE BY THE CORRESPONDING GOVERNMENTAL AGENCY.**

Resale of ST products with provisions different from the statements and/or technical features set forth in this document shall immediately void any warranty granted by ST for the ST product or service described herein and shall not create or extend in any manner whatsoever, any liability of ST.

ST and the ST logo are trademarks or registered trademarks of ST in various countries.

Information in this document supersedes and replaces all information previously supplied.

The ST logo is a registered trademark of STMicroelectronics. All other names are the property of their respective owners.

© 2013 STMicroelectronics - All rights reserved

STMicroelectronics group of companies

Australia - Belgium - Brazil - Canada - China - Czech Republic - Finland - France - Germany - Hong Kong - India - Israel - Italy - Japan - Malaysia - Malta - Morocco - Philippines - Singapore - Spain - Sweden - Switzerland - United Kingdom - United States of America

[www.st.com](http://www.st.com)