

NM93C46A

1K-Bit Serial CMOS EEPROM (MICROWIRE™ Synchronous Bus)

General Description

The NM93C46A is 1,024 bits of CMOS nonvolatile, electrically erasable memory available as either 64 16-bit registers or 128 8-bit registers. (The organization is determined by the status of the ORG input.) This is fabricated using Fairchild Semiconductor's floating gate CMOS process for high reliability, high endurance, and low power consumption. The NM93C46A is available in 8-pin DIP, SO and TSSOP packages for space considerations.

The EEPROM is MICROWIRE compatible for simple interfacing to a wide variety of microcontrollers and microprocessors. There are 7 instructions that operate the NM93C46A: Read, Erase/Write Enable, Erase, Write, Erase/Write Disable, Write All, and Erase All.

The NM93C46A defaults to the 64 x 16 configuration if the ORG pin (Pin 6) is left floating, as it is internally pulled up to V_{CC}.

Features

- 2.7V to 5.5V operation in all modes
- Typical active current 200µA
10 µA standby current typical
1 µA standby current typical (L)
0.1 µA standby current typical (LZ)
- Self-timed programming cycle
- Device status indication during programming mode
- No erase required before write
- Reliable CMOS floating gate technology
- MICROWIRE compatible serial I/O
- 40 years data retention
- Endurance: 1,000,000 data changes
- Packages available: 8-pin TSSOP, 8-pin SO, 8-pin DIP

Block Diagram

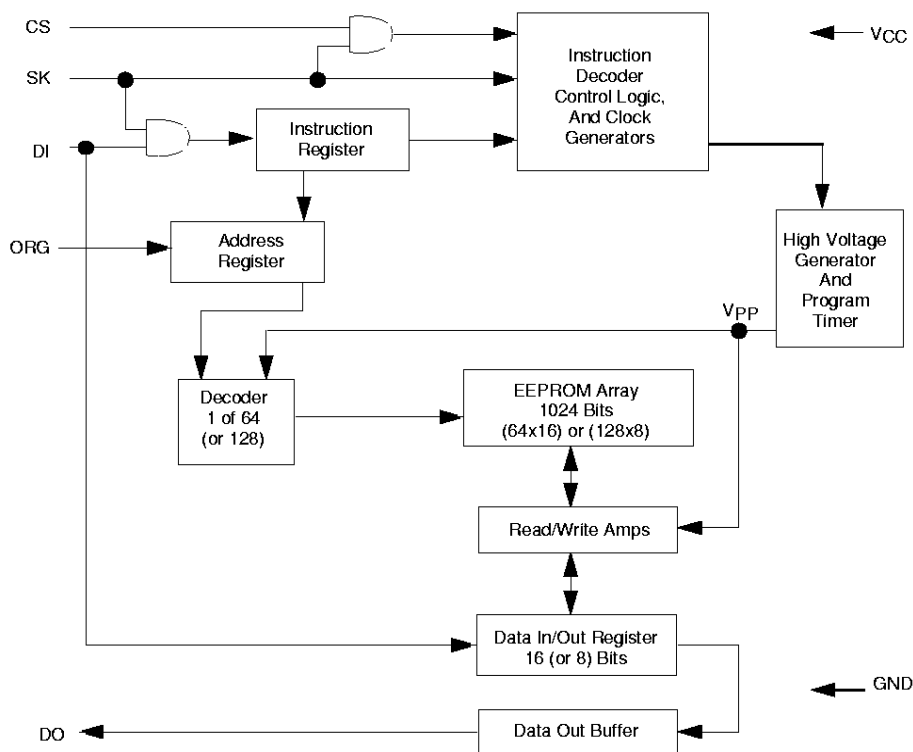

DS011042-1

Connection Diagrams

Dual-In-Line Package (N),
8-Pin SO Package (M8)
and 8-Pin TSSOP Package (MT8)

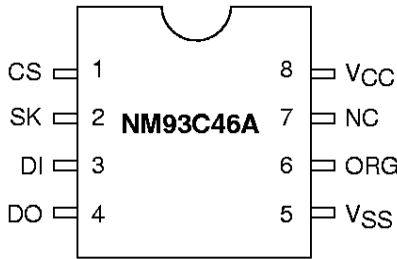

Rotated Die
(93C46AT)

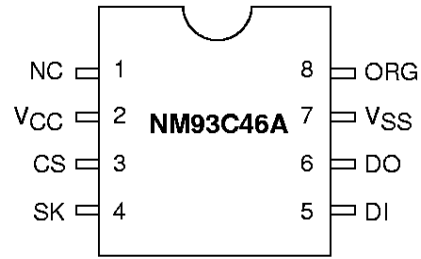

DS011042-2

Top View

See Package Number N08E, M08A and MTC08

Pin Names

CS	Chip Select
SK	Serial Data Clock
DI	Serial Data Input
DO	Serial Data Output
V _{SS}	Ground
ORG	Memory Organizational Select
NC	No Connect
V _{CC}	Positive Power Supply

Ordering Information

NM	93	C	XX	A	T	LZ	E	XX		
									Package	N M8 MT8
									Temp. Range	None V E
									Voltage Operating Range	Blank L LZ
										Blank T
									Density	A 46
										C CS
									Interface	93 NM
									Letter Description	8-Pin DIP 8-Pin SO8 8-Pin TSSOP 0 to 70°C -40 to +125°C -40 to +85°C 4.5V to 5.5V 2.7V to 4.5V 2.7V to 4.5V and <1µA Standby Current Normal Pin Out Rotated Die Pin Out x8 or x16 Configuration 1K CMOS Data protect and sequential read MICROWIRE Fairchild Non-Volatile Memory

Absolute Maximum Ratings (Note 1)

Ambient Storage Temperature	-65°C to +150°C
All Input or Output Voltages: with Respect to Ground	$V_{CC} + 1$ to $-0.3V$
Lead Temperature (Soldering, 10 Seconds)	+300°C
EDS Rating	2000V

Operating Range

Ambient Operating Temperature	0°C to +70°C
NM93C46A	-40°C to +85°C
NM93C46AE	-40°C to +125°C
NM93C46AV	
Power Supply (V_{CC})	4.5V to 5.5V

Standard V_{CC} (4.5V to .5V) DC and AC Electrical Characteristics

Symbol	Parameter	Part Number	Conditions	Min	Max	Units
I_{CCA}	Operating Current		$CS = V_{IH}$, $SK=1$ MHz		1	mA
I_{CCS}	Standby Current		$CS = 0V$, $ORG = V_{CC}$ or NC		50	μA
I_{IL}	Input Leakage		$V_{IN} = 0V$ to V_{CC} (Note 2)	-1	1	μA
I_{ILO}	Input Leakage ORG Pin		ORG tied to V_{CC} ORG tied to V_{SS} (Note 3)	-1 -2.5	1 2.5	μA
I_{OL}	Output Leakage		$V_{IN} = 0V$ to V_{CC}	-1	1	μA
V_{IL}	Input Low Voltage			-0.1	0.8	V
V_{IH}	Input High Voltage			2	$V_{CC} + 1$	V
V_{OL1}	Output Low Voltage		$I_{OL} = 2.1$ mA		0.4	V
V_{OH1}	Output High Voltage		$I_{OH} = -400$ μA	2.4		V
V_{OL2}	Output Low Voltage		$I_{OL} = 10$ μA		0.2	V
V_{OH2}	Output High Voltage		$I_{OL} = -10$ μA	$V_{CC} - 0.2$		V
f_{SK}	SK Clock Frequency		(Note 4)	0	1	MHz
t_{SKH}	SK High Time	NM93C46A NM93C46AE/V		250 300		ns
t_{SKL}	SK Low Time			250		ns
t_{SKS}	SK Setup Time		SK must be at V_{IL} for t_{SKS} before CS goes high	50		ns
t_{CS}	Minimum CS		(Note 5)	250		ns
t_{CSS}	CS Setup Time			50		ns
t_{DH}	DO Hold Time			70		ns
t_{DIS}	DI Setup Time	NM93C46A NM93C46AE/V		100 200		ns
t_{CSH}	CS Hold Time			0		ns
t_{DIH}	DI Hold Time			20		ns
t_{PD1}	Output Delay to "1"				500	ns
t_{PD0}	Output Delay to "0"				500	ns
t_{SV}	CS to Status Valid				500	ns
t_{DF}	CS to DO in TRI-STATE $\text{\textcircled{B}}$		$CS = V_{IL}$		100	ns
t_{WP}	Write Cycle Time				10	ms

Absolute Maximum Ratings (Note 1)

Ambient Storage Temperature	-65°C to +150°C
All Input or Output Voltage with Respect to Ground	+6.5V to -0.3V
Lead Temperature (Soldering, 10 sec.)	+300°C
ESD Rating	2000V

Operating Range

Ambient Operating Temperature	0°C to +70°C
NM93C46AL/LZ	-40°C to +85°C
NM93C46ALE/LZE	-40°C to +125°C
NM93C46A LV/LZV	
Power Supply (V _{CC})	2.7V to 4.5V

Low V_{CC} (2.7V to 4.5V) DC and AC Electrical Characteristics

Symbol	Parameter	Part Number	Conditions	Min.	Max.	Units
I _{CCA}	Operating Current		CS = V _{IH} , SK = 250KHz		1	mA
I _{CCS}	Standby Current		CS = V _{IL}		10	μA
	L				1	μA
	LZ					
I _{IL}	Input Leakage		V _{IN} = 0V to V _{CC} (Note 2)		±1	μA
I _{ILO}	Input Leakage		ORG tied to V _{CC}	-1	1	μA
	ORG Pin		ORG tied to V _{SS} (Note 3)	-2.5	2.5	μA
I _{OL}	Output Leakage		V _{IN} = 0V to V _{CC}		±1	μA
V _{IL}	Input Low Voltage			-0.1	0.15 V _{CC}	V
V _{IH}	Input High Voltage			0.8 V _{CC}	V _{CC} + 1	V
V _{OL}	Output Low Voltage		I _{OL} = 10 μA		0.1 V _{CC}	V
V _{OH}	Output High Voltage		I _{OH} = -10 μA	0.9 V _{CC}		V
f _{SK}	SK Clock Frequency		(Note 4)	0	250	KHz
t _{SKH}	SK High Time			1		μs
t _{SKL}	SK Low Time			1		μs
t _{SKS}	SK Setup Time		SK must be at V _{IL} for t _{SKS} before CS goes high	0.2		μs
t _{CS}	Minimum CS Low Time		(Note 5)	1		μs
t _{CSS}	CS Setup Time			0.2		μs
t _{DH}	DO Hold Time			70		ns
t _{DIS}	DI Setup Time			0.4		μs
t _{CSH}	CS Hold Time			0		ns
t _{DIH}	DI Hold Time			0.4		μs
t _{PD1}	Output Delay to "1"				2	μs
t _{PD0}	Output Delay to "0"				2	μs
t _{SV}	CS to Status Valid				1	μs
t _{DF}	CS to DO in TRI-STATE		CS = V _{IL}		0.4	μs
t _{WP}	Write Cycle Time				15	ms

Capacitance T_A = 25°C, f = 1 MHz

Symbol	Test	Typ	Max	Units
C _{OUT}	Output Capacitance		5	pF
C _{IN}	Input Capacitance		5	pF

Note 1 Stress above those listed under "Absolute Maximum Ratings" may cause permanent damage to the device. This is a stress rating only and functional operation of the device at these or any other conditions above those indicated in the operational sections of the specification is not implied. Exposure to absolute maximum rating conditions for extended periods may affect device reliability.

Note 2 Typical leakage values are in the 20 nA range.

Note 3 The ORG pin may draw > 1 μA when in the x8 mode due to an internal pull-up transistor.

Note 4 The shortest allowable SK clock period = 1/f_{SK} (as shown under the f_{SK} parameter). Maximum SK clock speed (minimum SK period) is determined by the interaction of several AC parameters stated in the datasheet. Within this SK period, both t_{SKH} and t_{SKL} limits must be observed. Therefore, it is not allowable to set 1/f_{SK} = t_{SKMinimum} + t_{SKMinimum} for shorter SK cycle time operation.

Note 5 CS (Chip Select) must be brought low (to V_{IL}) for an interval of t_{CS} in order to reset all internal device registers (device reset) prior to beginning another opcode cycle. (This is shown in the opcode diagrams in the following pages.)

AC Test Conditions

V _{CC} Range	V _{IL} /V _{IH} Input Levels	V _{IL} /V _{IH} Timing Level	V _{OL} /V _{OH} Timing Level	I _{OL} /I _{OH}
2.7V ≤ V _{CC} ≤ 5.5V (Extended Voltage Levels)	.03V/1.8V	1.0V	0.8V/1.5V	±10μA
4.5V ≤ V _{CC} ≤ 5.5V (TTL Levels)	0.4V/2.4V	1.0V/2.0V	0.4V/2.4V	-2.1mA/0.4mA
Output Load: 1 TTL Gate (C _L = 100 pF)				

MICROWIRE I/O Pin Description

Chip Select (CS):

This pin enables and disables the MICROWIRE device and performs 3 general functions:

1. When in the low state, the MICROWIRE device is disabled and the output tri-stated (high impedance). If this pin is brought high (rising edge active), all internal registers are reset and the device is enabled, allowing MICROWIRE communication via DI/DO pins. To restate, the CS pin must be held high during all device communication and opcode functions. If the CS pin is brought low, all functions will be disabled and reset when CS is brought high again. The exception to this is when a programming cycle is initiated (see 2 and 3). Again, all activity on the CS, DI and DO pins is ignored until CS is brought high.
2. After entering all required opcode and address data, bringing CS low initiates the (asynchronous) programming cycle.
3. When programming is in progress, the Data-Out pin will display the programming status as either BUSY (DO low) or READY (DO high) when CS is brought high. (Again, the output will be tri-stated when CS is low.) To restate, during programming, the CS pin may be brought high and low any number of times to view the programming status without affect the programming operation. Once programming is completed (Output in READY state), the output is 'cleared' (returned to normal tri-state condition) by clocking in a Start Bit. After the Start Bit is clocked in, the output will return to a tri-stated condition. When clocked in, this Start Bit can be the first bit in a command string, or CS can be brought low again to reset all internal circuits.

Serial Clock (SK):

This pin is the clock input (rising edge active) for clocking in all opcodes and data on the DI pin and clocking out all data on the DO pin. However, this pin has no effect on the asynchronous programming cycle (see the CS pin section) as the BUSY/READY status is a function of the CS pin only.

Data-In (DI):

All serial communication *into* the device is performed using this input pin (rising edge active). In order to avoid false Start Bits, or related issues, it is advised to keep the DI pin in the low state unless actually clocking in data bits (Start Bit, Opcode, Address or incoming data bits to be programmed). Please note that the first '1' clocked into the device (after CS is brought high) is seen as a Start Bit and the beginning of a serial command string, so caution must be observed when bringing CS high.

Data-Out (DO):

All serial communication *out of* the device (READ opcode) is performed using this output pin (rising edge active) as well as indicating the READY/BUSY status during the asynchronous programming cycle. Note that, during READ operations, the output data is clocked *out* after the last address bit (A0) is clocked in. If a 3-wire application is required (where DI and DO are tied together), sections in AN-758, or related application notes, must be followed for correct operation.

Organization (ORG):

This pin controls the device architecture (8-bit data word vs. 16-bit data word). If the ORG pin is brought to V_{CC} , the device is configured with a 16-bit data word and if the ORG pin is brought to V_{SS} (Ground), the device is configured with an 8-bit data word (refer to other sections for details of both configurations). If the ORG pin is left floating, the device will default to a 16-bit data word.

Instruction Set for the NM93C46A

ORG Pin Logic	Memory	
	Configuration	# of Address Bits
0	128 x 8	7 Bits
1	64 x 16	6 Bits

64 by 16-Bit Organization (NM93C46A when $ORG = V_{CC}$ or NC)

Instruction	SB	OP-Code 2 Bits	Address 6 Bits	Data 16 Bits	Comments
READ	1	10	A5–A0		Read data stored in selected registers.
EWEN	1	00	11XXXX		Enables programming modes.
EWDS	1	00	00XXXX		Disables all programming modes.
ERASE	1	11	A5–A0		Erases selected register.
WRITE	1	01	A5–A0	D15–D0	Writes data pattern D15–D0 into selected register.
ERAL	1	00	10XXXX		Erases all registers.
WRAL	1	00	01XXXX	D15–D0	Writes data pattern D15–D0 into all registers.

128 by 8-Bit Organization (NM93C46A when $ORG = GND$)

Instruction	SB	OP-Code 2 Bits	Address 7 Bits	Data 8 Bits	Comments
READ	1	10	A6–A0		Read data stored in selected registers.
EWEN	1	00	11XXXXX		Enables programming modes.
EWDS	1	00	00XXXXX		Disables all programming modes.
ERASE	1	11	A6–A0		Erases selected register.
WRITE	1	01	A6–A0	D7–D0	Writes data pattern D7–D0 into selected register.
ERAL	1	00	10XXXXX		Erases all registers.
WRAL	1	00	01XXXXX	D7–D0	Writes data pattern D7–D0 into all registers.

Functional Description

Programming:

1. Programming is initiated by clocking in the Start Bit, Opcode bits, Address bits and the 8/16 data bits (refer to the ORG pin section).
2. Programming is started by bringing the CS pin low. Once the programming cycle is started, it cannot be stopped. (Bringing V_{CC} low will stop any programming, but will also result in data corruption.)
3. The status of the programming cycle (BUSY or READY) is observed by bringing the CS pin high and observing the output state. If the output is LOW, the device is still programming (BUSY). If the output is HIGH, the programming cycle has been completed and the device is ready for the next operation. Note that the output will be tri-stated each time CS is brought low and the R/B status will be shown each time CS is brought high.
4. After programming, the READY state (output HIGH) can be reset and the output tri-stated by clocking in a single Start Bit. This Start Bit can be the first bit in a command string, or CS can be brought low again to reset all internal circuits. In any case, clocking in a '1' bit will tri-state the output.

Read (READ):

The READ instruction outputs serial data on the DO pin. After a READ instruction is received, the instruction and address are decoded, followed by data transfer from the selected memory register into a serial-out shift register. A dummy bit (logical 0) precedes the serial data output string. Output data changes are initiated by a low to high transition of SK after the last address bit (A0) is clocked in.

Erase/Write Enable (EWEN):

When V_{CC} is applied to the part, it "powers up" in the Erase/Write Disable (EWDS) state. Therefore, all programming modes must be preceded by an Erase/Write Enable (EWEN) instruction. Once an Erase/Write Enable instruction is executed, programming remains enabled until an Erase/Write Disable (EWDS) instruction is executed or V_{CC} is removed from the part.

Functional Description (Continued)

Erase/Write Disable (EWDS):

To protect against accidental data overwrites, the Erase/Write Disable (EWDS) instruction disables all programming modes and should follow all programming operations. Execution of a READ instruction is independent of both the EVEN and EWDS instructions.

Erase (ERASE):

The ERASE instruction will program all bits in the specified register to the logical "1" state. Please refer to the Programming section for details.

Write (WRITE):

The WRITE instruction is followed by 16 bits of data (or 8 bits of data when using the NM93C46A in the x8 organization) to be written into the specified address. Please refer to the Programming section for details.

Erase All (ERAL):

The ERAL instruction will simultaneously program all registers in the memory array to the logical "1" state.

Write All (WRAL):

The WRAL instruction will simultaneously program all registers with the data pattern specified in the instruction.

Timing Diagrams for the NM93C46A

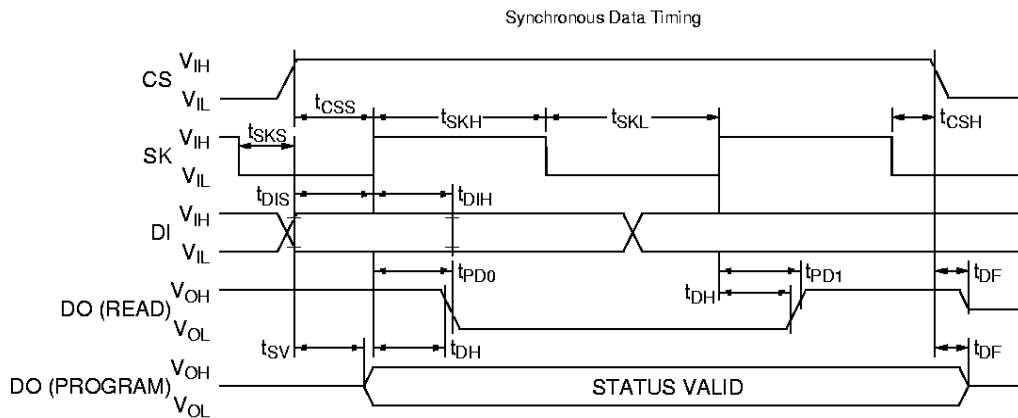

DS011042-4

Timing Diagrams for the NM93C46A (Continued)

Key for Timing Diagrams
Organization of Address and Data Fields for NM93C46A

ORG Pin	Organization	A _N	D _N
V _{CC} or NC	64 x 16	A5	D15
V _{SS}	128 x 8	A6	D7

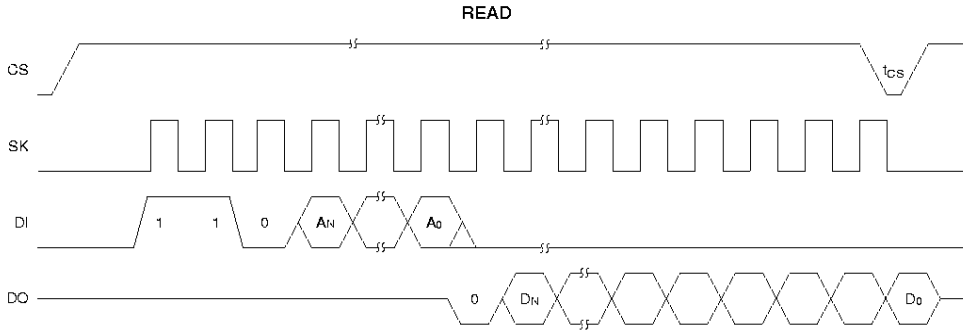

DS011042-5

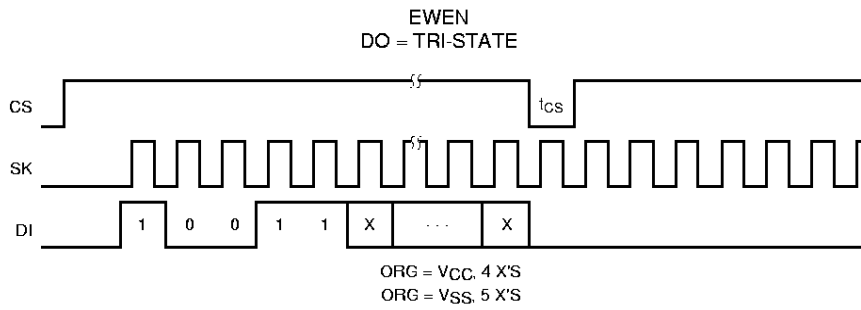

DS011042-6

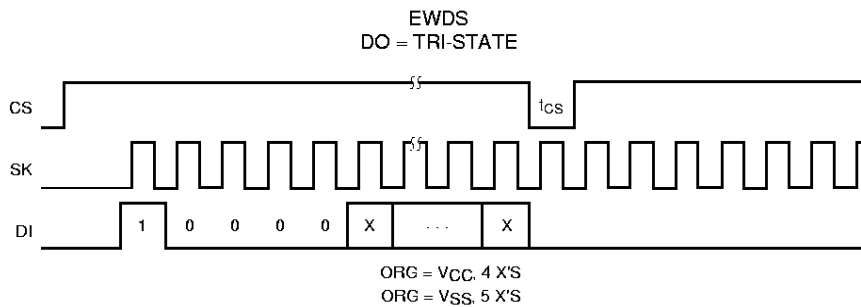

DS011042-7

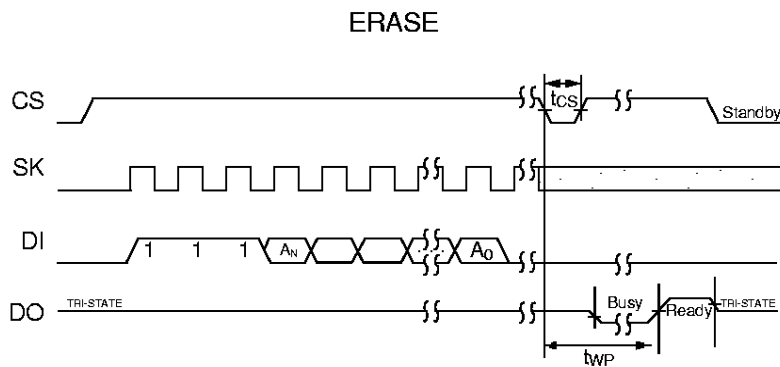

DS011042-8

Timing Diagrams for the NM93C46A (Continued)

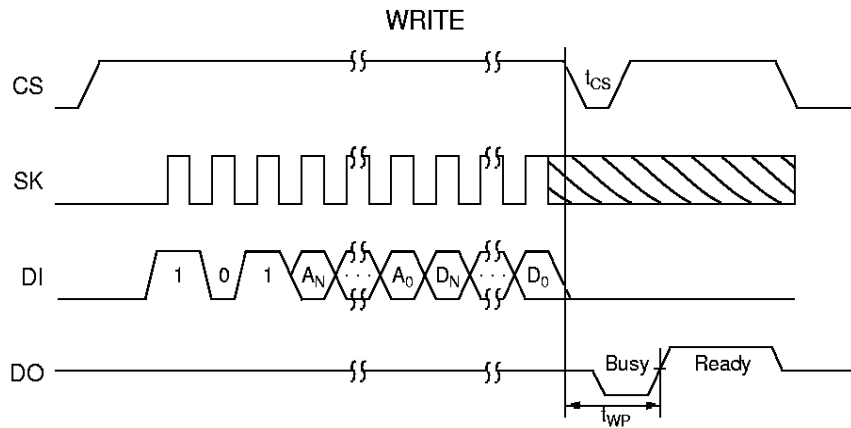

DS011042-9

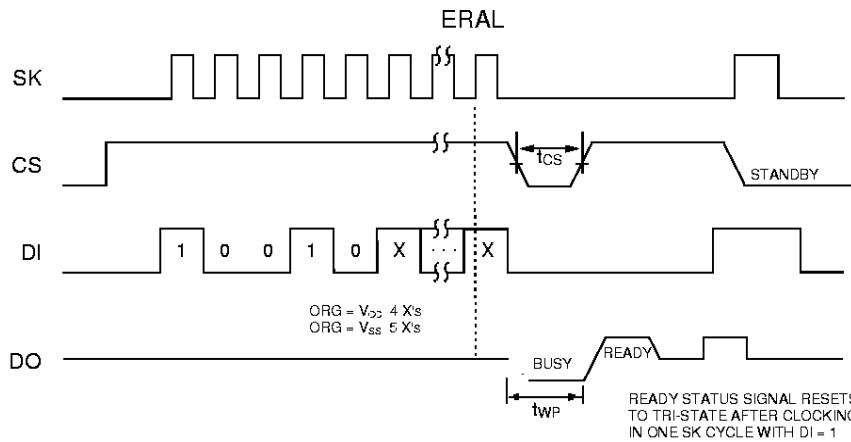

DS011042-10

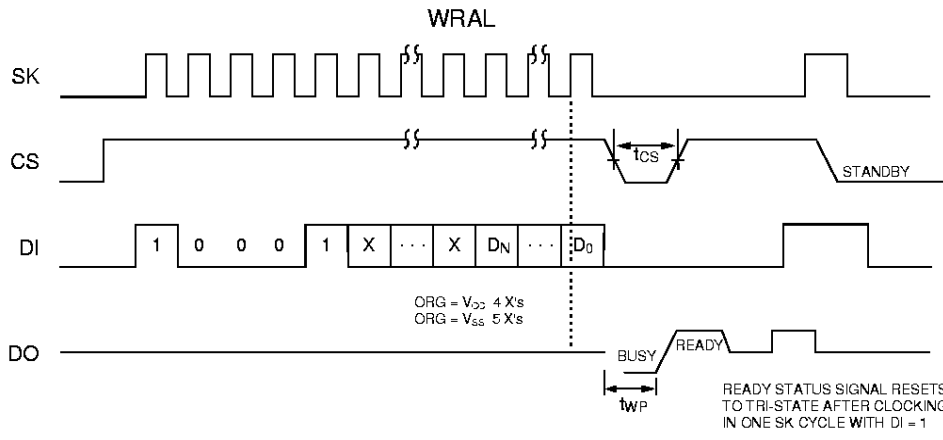

DS011042-11

Physical Dimensions inches (millimeters) unless otherwise noted

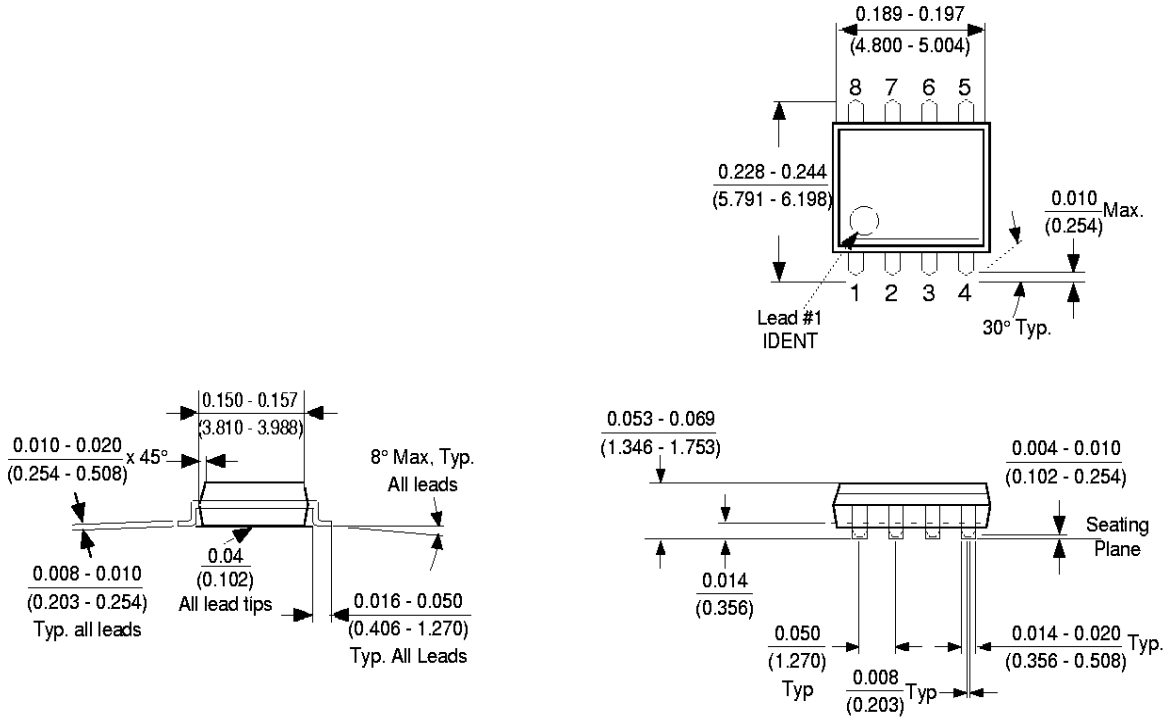

**Molded Small Outline Package (M8)
Package Number M08A**

Physical Dimensions inches (millimeters) unless otherwise noted

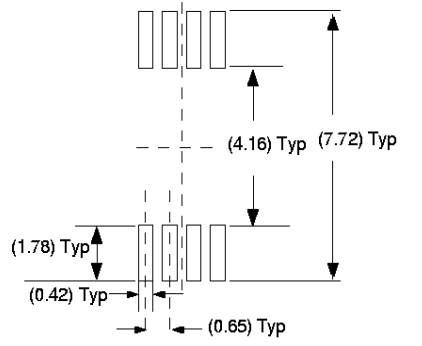
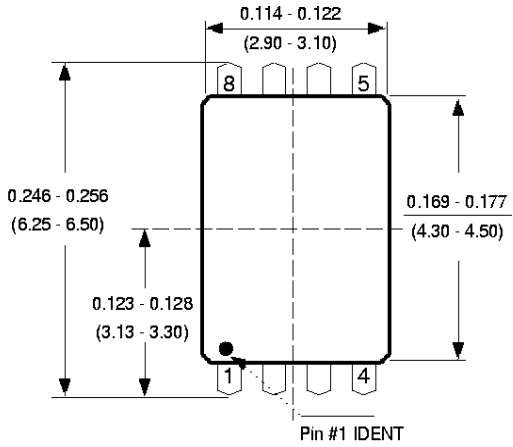

Land pattern recommendation

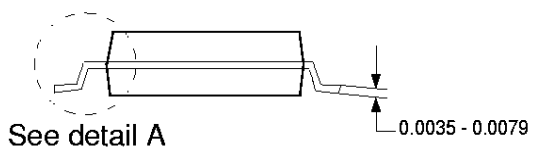
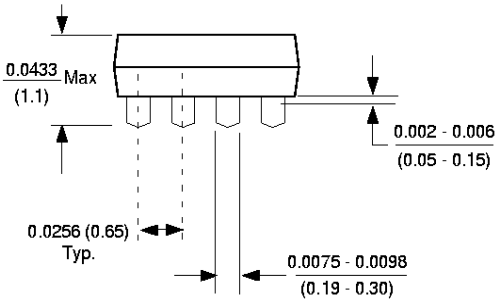

DETAIL A
Typ. Scale: 40X

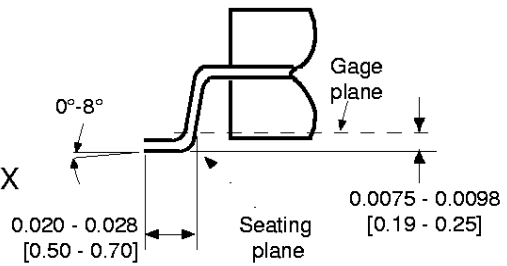

8-Pin Molded TSSOP, JEDEC (MT8)
Package Number MTC08

Physical Dimensions inches (millimeters) unless otherwise noted

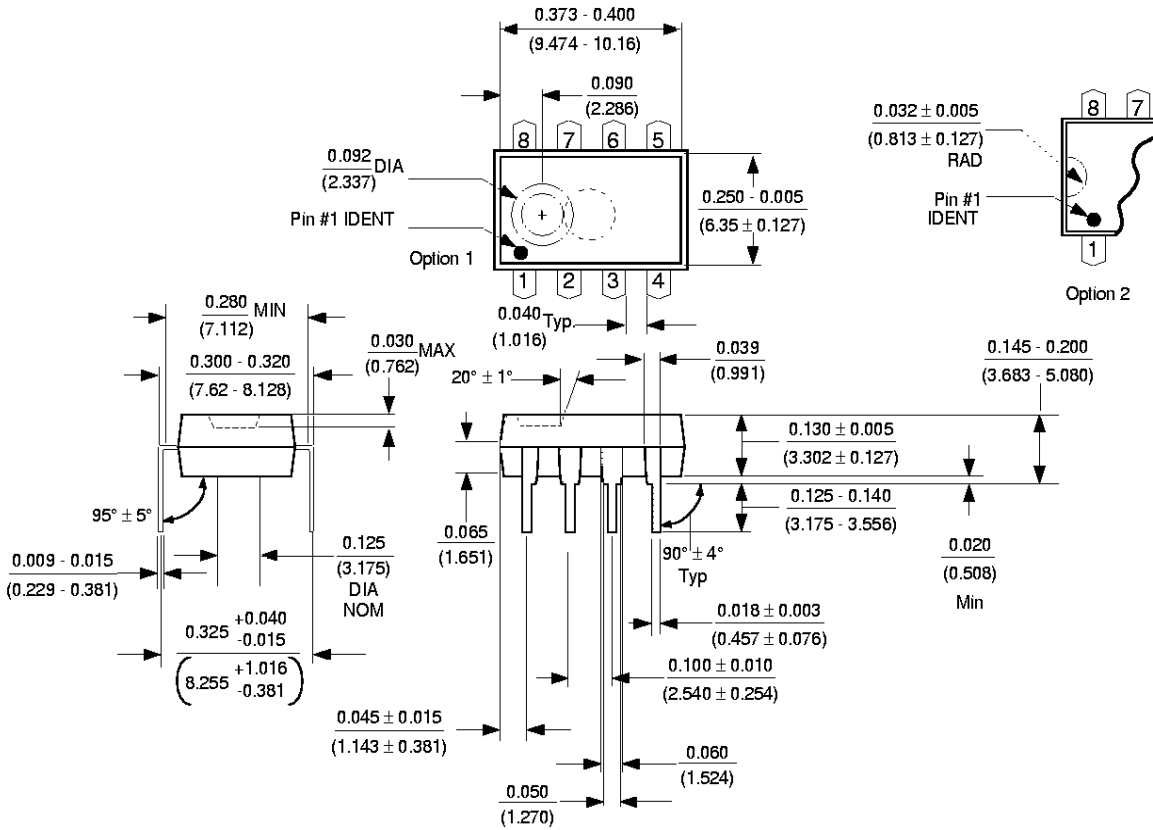

**Molded Dual-In-Line Package (N)
Package Number N08E**

Life Support Policy

Fairchild's products are not authorized for use as critical components in life support devices or systems without the express written approval of the President of Fairchild Semiconductor Corporation. As used herein:

1. Life support devices or systems are devices or systems which, (a) are intended for surgical implant into the body, or (b) support or sustain life, and whose failure to perform, when properly used in accordance with instructions for use provided in the labeling, can be reasonably expected to result in a significant injury to the user.
2. A critical component is any component of a life support device or system whose failure to perform can be reasonably expected to cause the failure of the life support device or system, or to affect its safety or effectiveness.

**Fairchild Semiconductor
Americas
Customer Response Center**
Tel 1-888-522-5372

**Fairchild Semiconductor
Europe**
Fax +44 (0) 1793-856856
Deutsch Tel +49 (0) 8141-6102-0
English Tel +44 (0) 1793-856856
Français Tel +33 (0) 1-6930-3696
Italiano Tel +39 (0) 2-249111-1

**Fairchild Semiconductor
Hong Kong**
8/F, Room 808, Empire Centre
68 Mody Road, Tsimshatsui East
Kowloon Hong Kong
Tel, +852-2722-8338
Fax +852-2722-8383

**Fairchild Semiconductor
Japan Ltd.**
4F, Natsume Bldg
2-18-6, Yushima, Bunkyo-ku
Tokyo, 113-0034 Japan
Tel 81-3-3818-8640
Fax 81-3-3818-8641