

## General Description

The MAX2181A evaluation kit (EV kit) simplifies evaluation of the MAX2181A FM low-noise amplifier. The EV kit enables testing of the device's features and performance and does not require additional support circuitry or software. The signal input and output use SMA connectors to facilitate connection of RF test equipment.

The EV kit is fully assembled with the device on board and incorporates input matching components for the U.S. FM broadcast band.

## Features

- Easy Evaluation of the MAX2181A
- +5V Single-Supply Operation
- RF Input and Output Matched to 50Ω
- Proven PCB Layout
- Fully Assembled and Tested

[Ordering Information](#) appears at end of data sheet.

## Quick Start

### Required Test Equipment

- RF signal generator (or generators) capable of delivering a signal in the 76MHz to 162.5MHz (FM) range at a power level of -34dBm. (A higher power source is required to measure distortion performance. See the [Measurements](#) section for more details)
- RF spectrum analyzer that covers the operating frequency range
- DC power supply capable of supplying +5V
- 50Ω cables with SMA connectors
- Ammeter to measure supply current (optional)
- Noise-figure meter to measure NF (optional)
- Network analyzer to measure gain and return loss (optional)

### Connections and Setup

#### Checking Gain

The EV kit is fully assembled and factory tested. Follow the steps below for proper device evaluation in the default configuration.

- 1) Connect a DC supply with its output disabled (preset to +5V) to the +5V and GND terminals (through an ammeter, if desired) on the EV kit.
- 2) Set the RF generator to the desired frequency at a power level of -37dBm. Disable the generator's output and connect it to the FMIN SMA connector on the EV kit.
- 3) Connect an SMA cable from the FMOUT SMA connector to the input of the spectrum analyzer.
- 4) Turn on the DC supply. The supply current should read approximately 56mA.
- 5) Activate the RF generator's output. The signal on the spectrum analyzer's display should indicate a typical gain, as shown on the MAX2181A IC data sheet after accounting for cable and board losses.

6) Optional: Another method of determining gain is by using a network analyzer. This has the advantage of displaying gain versus a swept frequency band, in addition to displaying input and output return loss. Refer to the user manual of the network analyzer for setup information. **Note:** Depending on the settings of the device’s maximum gain and power detector, the AGC loop can become active for input power levels as low as -24dBm. To ensure consistent results are obtained, the stimulus level of the network analyzer should be no greater than -34dBm, ensuring that the gain is unaffected by the AGC loop.

### Detailed Description of Hardware

#### Test Points

The MAX2181A signal path includes a power detector and AGC loop, which can be adjusted for maximum gain and AGC threshold. In addition, the AGC loop can be overridden by applying an external voltage to the FMAGC pin. [Table 1](#) describes how to control the performance of the device using the test points on the EV kit.

#### Measurements

##### Noise

Noise figure can be measured using a NF meter. Because of the large number of FM broadcast signals that might be present, this measurement should take place with the EV kit in a screen box or other type of RF shield.

#### Distortion

Two-tone distortion of the amplifier can be measured using a power combiner to couple the signals from two generators into FMIN on the EV kit. During closed-loop operation, as the signal levels increase, the device’s input impedance is reduced. At the upper end of the input signal level range, where each tone can be greater than 120dBµV, this reduced impedance could create distortion within the signal generators. For accurate distortion measurement, the input of the EV kit should be isolated from the signal generators and power combiner. This can be accomplished using a ferrite isolator.

#### Layout Considerations

##### Electrical

At high-signal-level conditions, the RF currents flowing in the device can induce voltages in the PCB ground plane, known as “ground bounce.” To avoid unwanted spurious products due to ground bounce, proper grounding techniques must be followed.

##### Thermal

An array of vias connected to the ground plane should be included to transfer heat away from the MAX2181A. Please refer to the EV Kit layout for an example of this.

**Table 1. Control Performance with Test Points**

TEST POINT	FUNCTION	DESCRIPTION
FMAGC	FM AGC loop control voltage	Applying a DC control voltage to FMAGC allows the user to override the AGC loop. 0V gives maximum gain; 5V gives minimum gain.
FMDT	FM AGC threshold	Sets the FM AGC threshold. Refer to the MAX2181A IC data sheet. Default value on the EV kit is 99dBµV (typ) referred to the FMOUT SMA connector (R1 = 43kΩ).
FMGAIN	FM gain control	Sets the maximum value of FM gain (FMAGC = 0V). Default setting on the EV kit is 6dB (typ) referred to the FMOUT SMA connector (R8 = 0Ω).

### Ordering Information

PART	TYPE
MAX2181AEVKIT#	EV Kit

#Denotes RoHS compliant.

## MAX2181A EV Kit Bill of Materials

REFERENCE DESIGNATOR	QTY	VALUE	TOLERANCE	DESCRIPTION	MANUFACTURER	PART NUMBER
C3, C9	2	0.1 $\mu$ F	10%	0603 Capacitor	Murata	GRM18871C105K
C4	1	2700pF	10%	0603 Capacitor	Murata	GRM1885C1H272K
C5	1	0.47 $\mu$ F	10%	0603 Capacitor	Murata	GRM188F51C474Z
C6	1	100pF	5%	0603 Capacitor	Murata	GRM1885C1H101J
C7	1	27pF	5%	0603 Capacitor	Murata	GRM1885C1H2700J
C10	1	10 $\mu$ F	10%	Tantalum Capacitor 'C' Case	AVX	TAJC106K035R
C11	0	<b>DNI</b>	10%	Tantalum Capacitor 'A' Case	AVX	TAJA106K010R Leave Site Open
FMAGC +5V(2)	3	Test Point		Test Point, PC Mini-Red	Keystone	5000
FMGAIN FMDET	0	Test Point <b>DNI</b>		Test Point, PC Mini-Red	Keystone	Leave Site Open
FMIN FMOUT	2	Connector		SMA Edge Mount-Round Contact	Johnson	142-0701-801
GND(2)	2	Test Point		Test Point, PC Mini-Black	Keystone	5001
L1	1	470nH	5%	0603 Inductor	Murata	LQW18ANR47J00
L2	0	<b>DNI</b>	5%	Midi Spring Air Core Inductor	Coilcraft	1812SMS-R10JL Leave Site Open
L3	1	82nH	5%	1008 Inductor	Murata	LQW2UAS82NJ00
R1	1	43k $\Omega$	5%	0603 Resistor		Use Lead-Free Only
R2	1	62 $\Omega$	5%	0603 Resistor		Use Lead-Free Only
R3	1	100 $\Omega$	5%	0603 Resistor		Use Lead-Free Only
R4	1	20K $\Omega$	5%	0603 Resistor		Use Lead-Free Only
R5, R6, R8	3	0 $\Omega$	5%	0603 Resistor		Use Lead-Free Only
U1	1	MAX2181A		AM/FM Automotive LNA	Maxim Integrated	MAX2181AETE/V+
—	1	—		PCB: MAX2181A EVALUATION KIT#	Maxim Integrated	MAX2181AEVKIT#

MAX2181A EV Kit Schematic

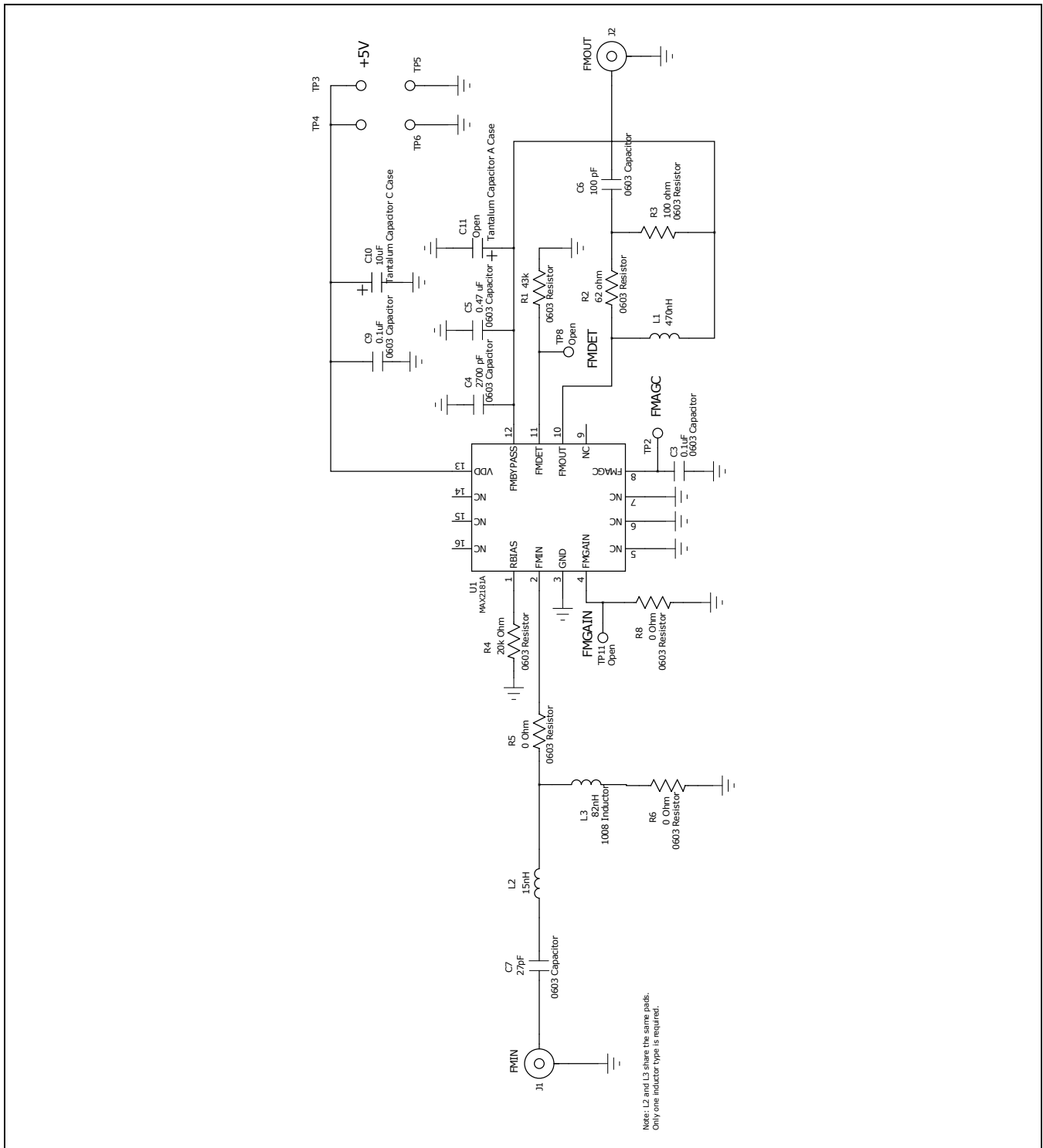

MAX2181A EV Kit Schematic

MAX2181A EV Kit PCB Layouts

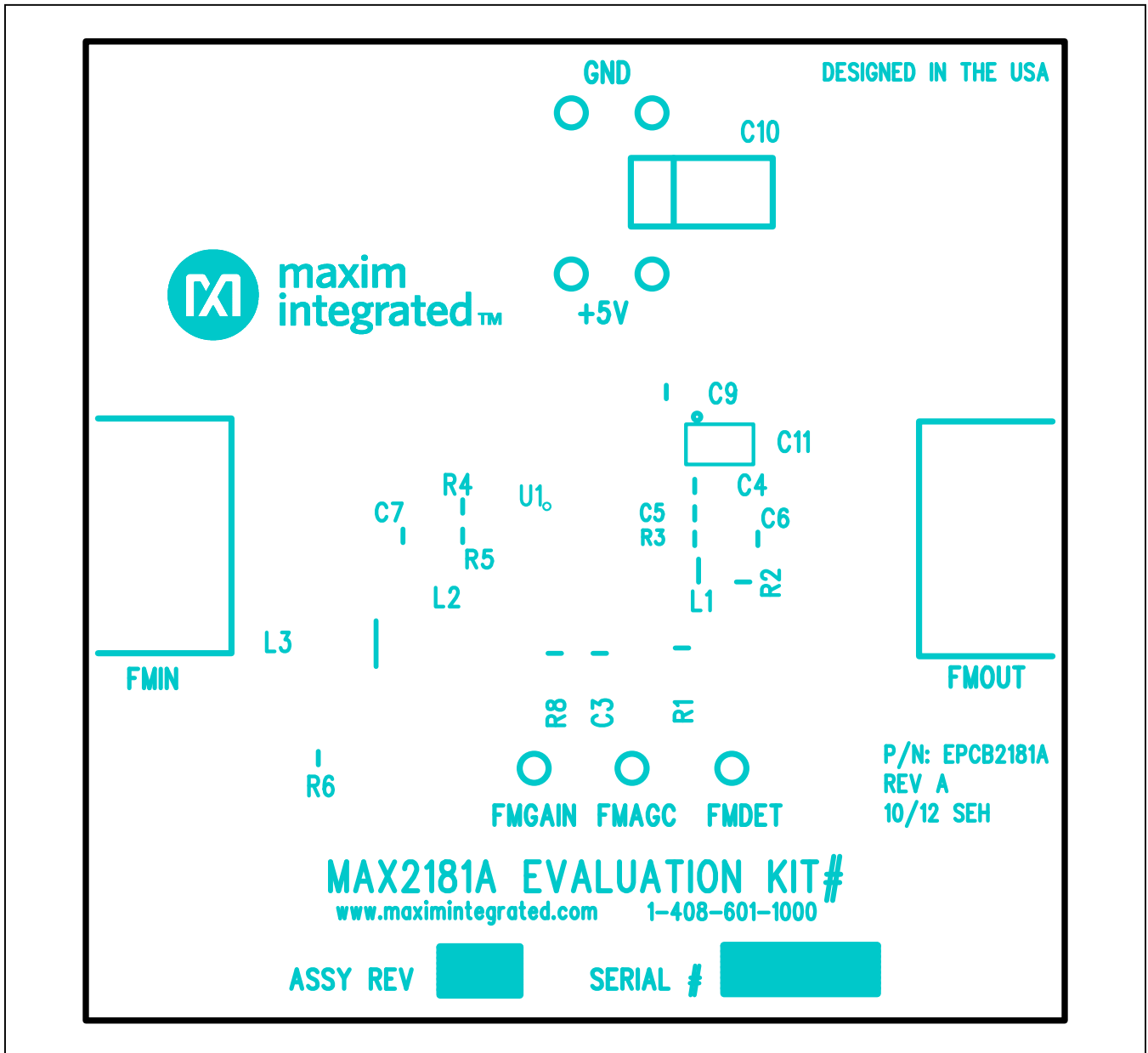

MAX2181A EV Kit Component Placement Guide—Top Silkscreen

MAX2181A EV Kit PCB Layouts (continued)

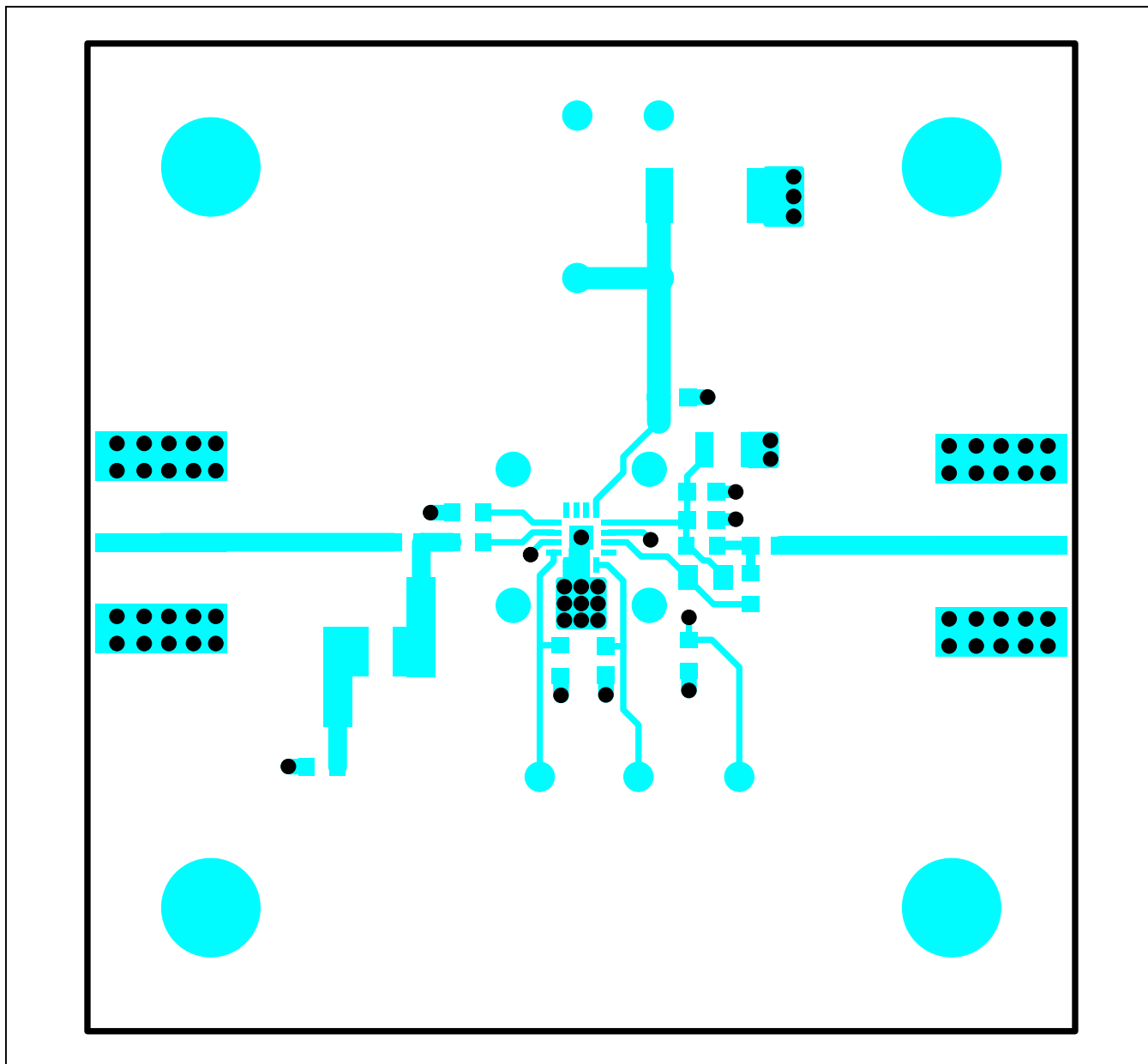

MAX2181A EV Kit PCB Layout—Top Copper

MAX2181A EV Kit PCB Layouts (continued)

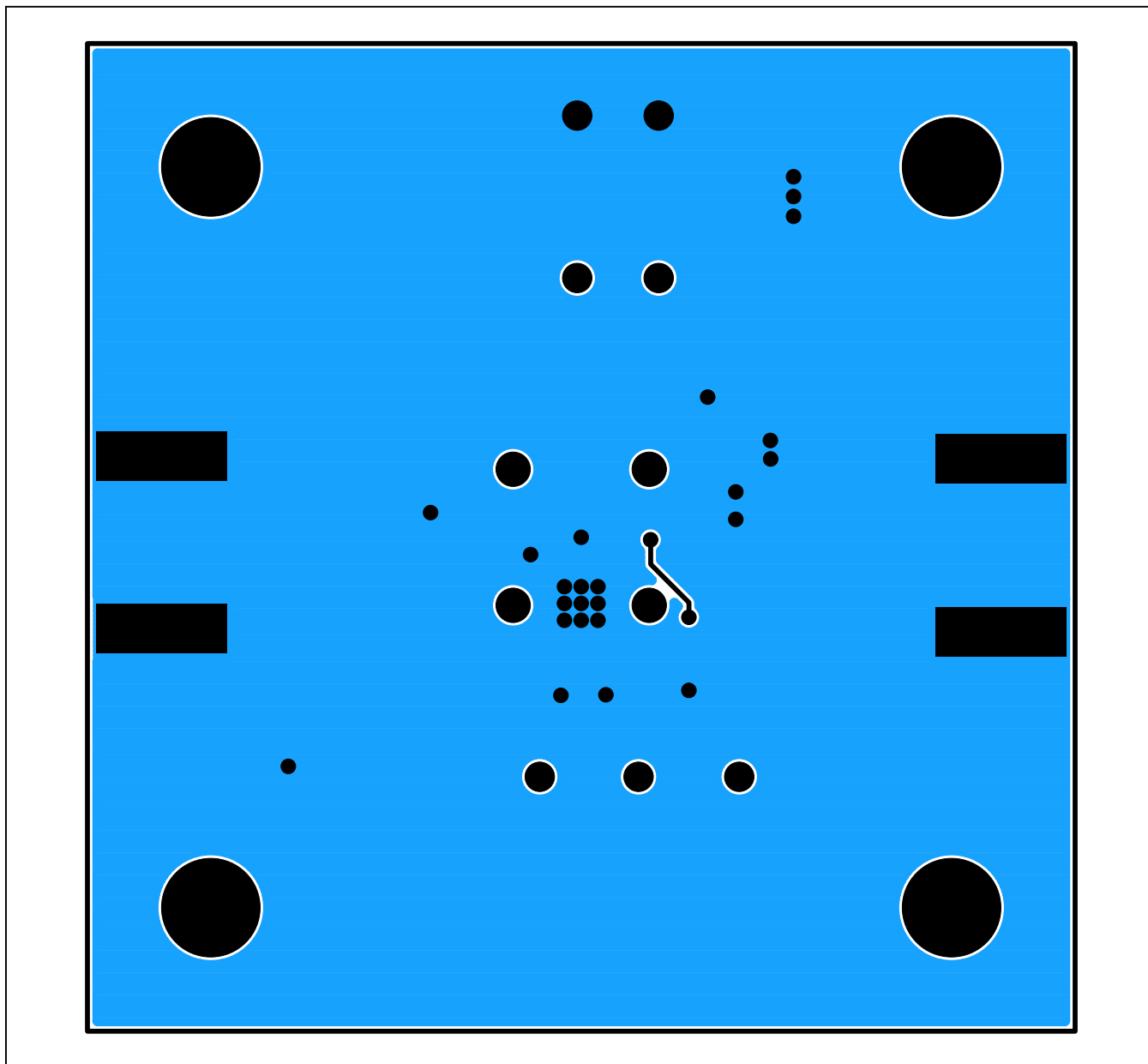

MAX2181A EV Kit PCB Layout—Bottom Copper

### Revision History

REVISION NUMBER	REVISION DATE	DESCRIPTION	PAGES CHANGED
0	4/17	Initial release	—

For pricing, delivery, and ordering information, please contact Maxim Direct at 1-888-629-4642, or visit Maxim Integrated's website at [www.maximintegrated.com](http://www.maximintegrated.com).

*Maxim Integrated cannot assume responsibility for use of any circuitry other than circuitry entirely embodied in a Maxim Integrated product. No circuit patent licenses are implied. Maxim Integrated reserves the right to change the circuitry and specifications without notice at any time.*