

# Seeed JetBot wiring Guide

We assume that you have installed the various components in accordance with the [Assembly Guide](#), and we will follow this guide to explain how to wire.

[Seeed JetBot wiring Guide](#)

[Camera to Jetson Nano](#)

[OLED to Jetson Nano](#)

[DC Motors to Motor Driver Board](#)

[Motor Driver Board to Jetson Nano](#)

## Camera to Jetson Nano

JetBot uses Raspberry Pi Camera V2, you can connect the camera to Jetson Nano by following the instructions below.

- **Step 1.** Insert the FPC cable into the camera (Blue side facing the camera)
- **Step 2.** Pass the FPC cable through the Jetbot body and reach the other end of Jetson Nano
- **Step 3.** Insert the FPC cable into the Jetson Nano (Blue side facing the Jetson Nano)



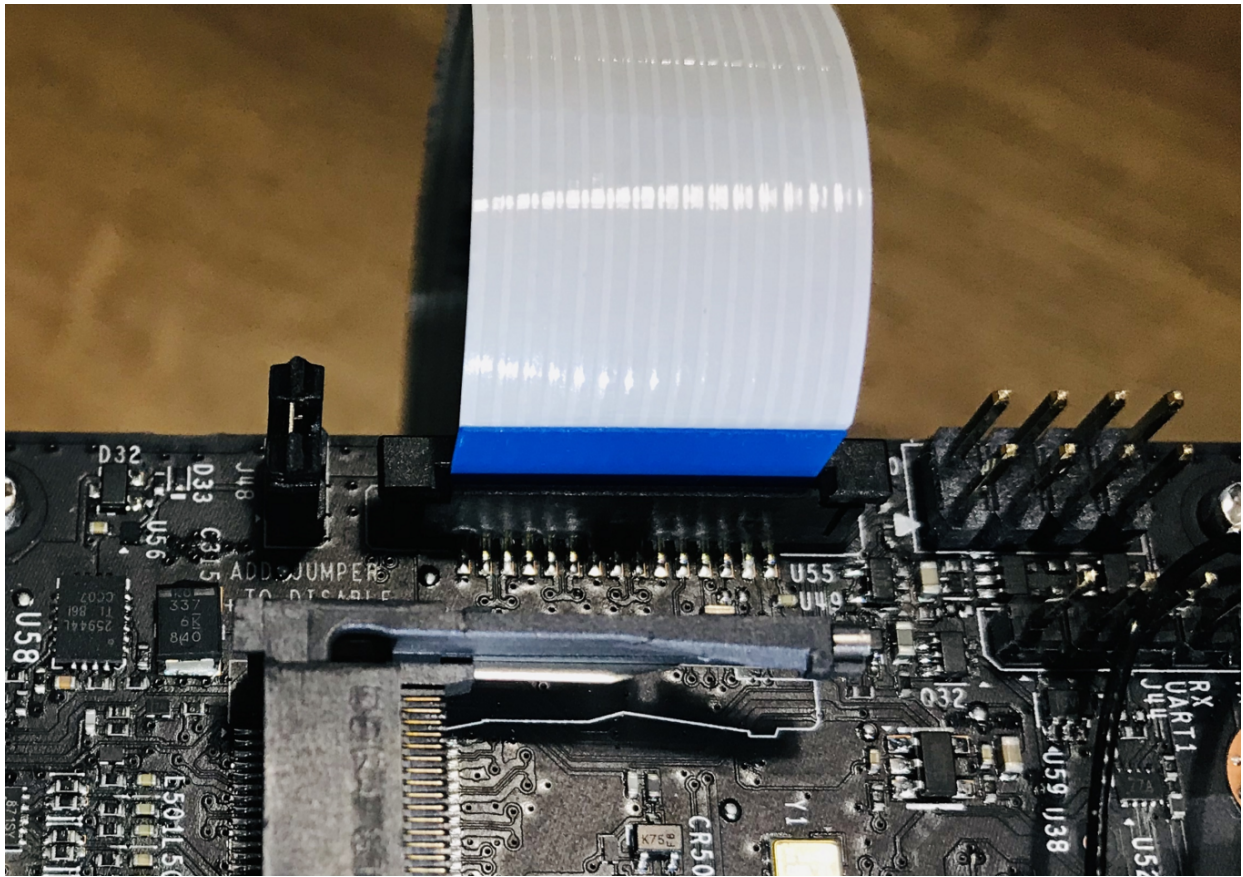

## OLED to Jetson Nano

We use a 0.91 inch OLED to display the IP and other information, to assemble this display, you need to first assemble an adapter pinboard on the Jetson Nano Header.

- **Step 1.** Plug the Pinboard into the 20x2 Header of Jetson Nano
- **Step 2.** Plug the 0.91 inch OLED into this Pinboard

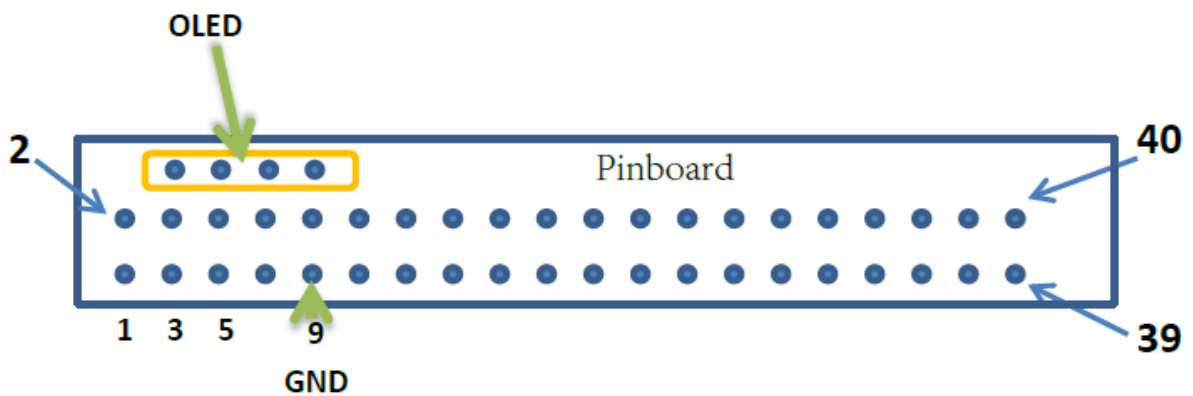

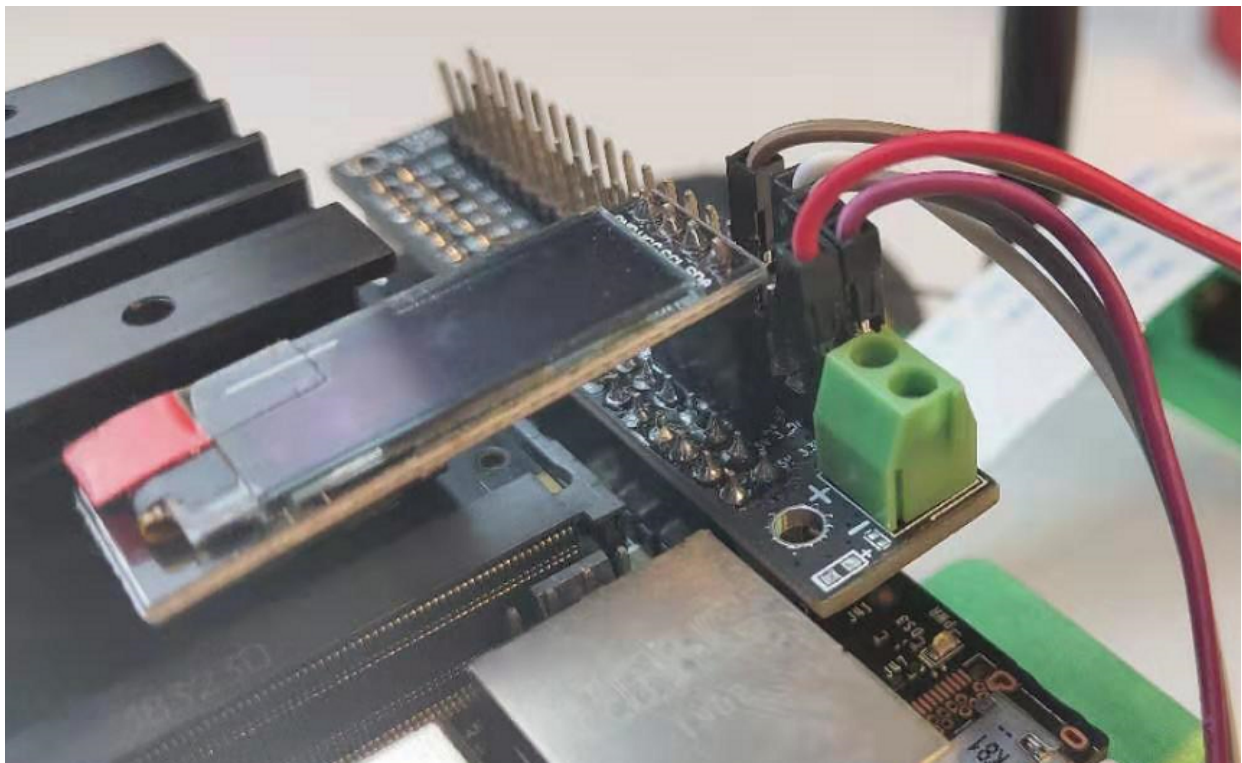

## DC Motors to Motor Driver Board

DC motor wiring is simple, just wire as the following image, The black wire is connected to the corresponding inner terminal, the red wire of the left motor is connected to the leftmost terminal, and the red wire of the right motor is connected to the rightmost terminal.

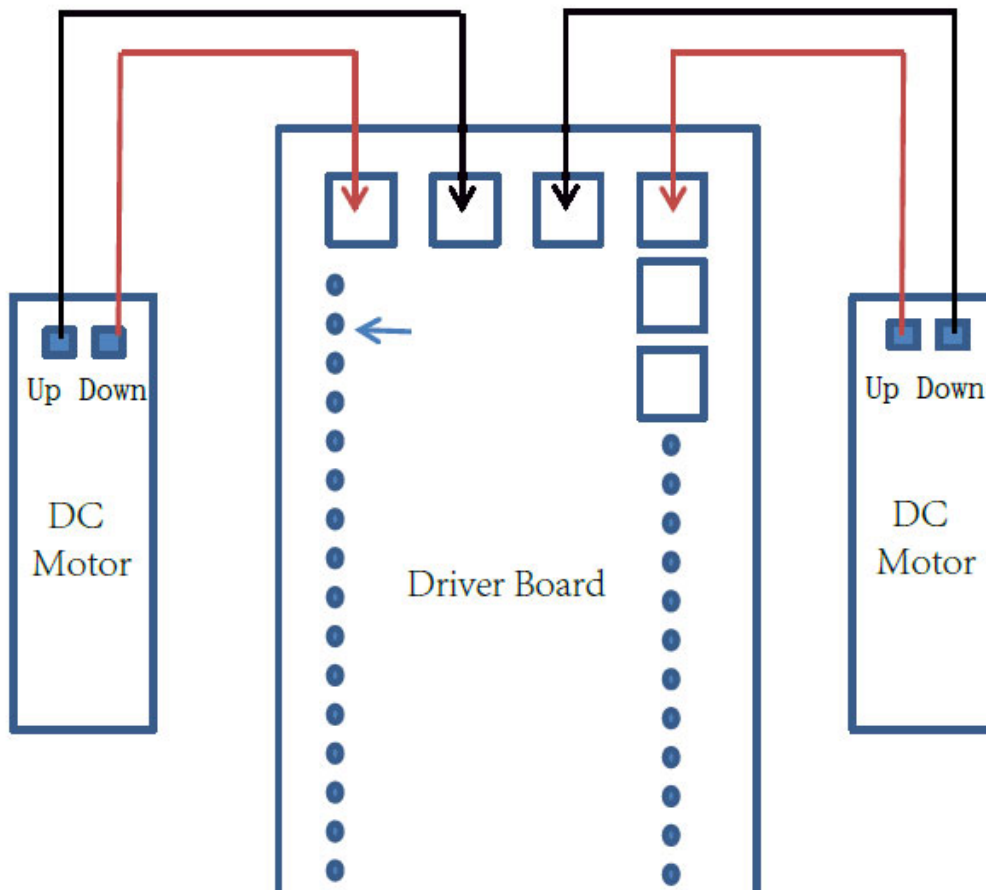

Physical picture

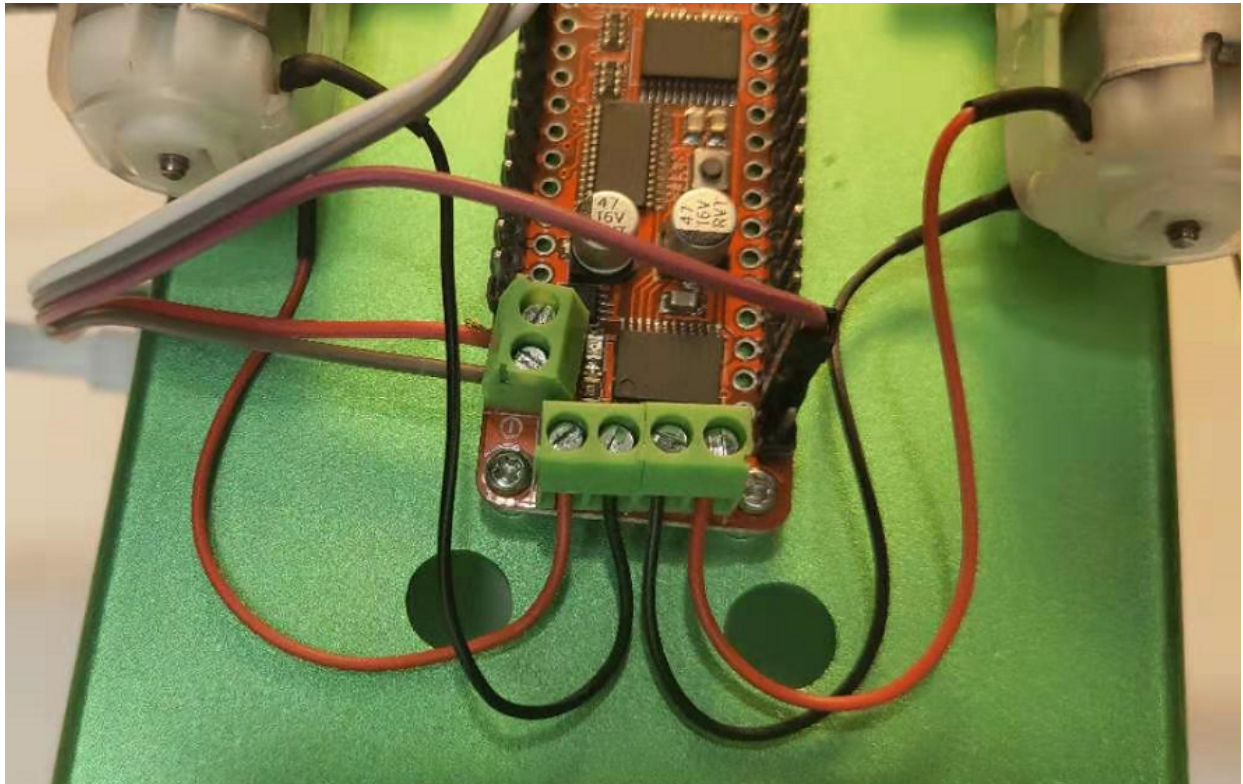

## Motor Driver Board to Jetson Nano

As the OLED display, we connect the Motor Driver Board to Jetson Nano via the Pinboard. We have labeled the pins of Motor Driver Board and Jetson Nano. You only need to connect the pins with the same number through the jumpers.

