

4.5V to 28V, 3A 1ch Synchronous Buck Converter Integrated FET

BD95513MUV

General Description

BD95513MUV is a switching regulator with current capability of 3A and the ability to achieve low output voltages of 0.7V to 5.0V from a wide input voltage range of 4.5V to 28V. It has built-in N-MOS power transistors and implementation of Simple Light Load Mode (SLLM™) technology make this device highly-efficient. SLLM™ improves efficiency when the device is used with light load, providing high efficiency over a wider range of loads. The device also uses a new technology called H³Reg™ proprietary control method, to achieve ultra-fast transient response against load changes. BD95513MUV is especially designed for various applications and is integrated with protection features such as soft-start, variable frequency, short circuit protection with timer latch, over voltage protection, and power good function.

Features

- Integrated 5V Linear Voltage Regulator
- H³Reg™ DC/DC Converter Controller
- Adjustable Simple Light Load Mode (SLLM™), Quiet Light Load Mode (QLLM) and Forced Continuous Mode
- Built-in Thermal Shutdown (TSD), Low Input, Over Current Protection (OCP), Over Voltage Protection (OVP) and Under Voltage Lockout (UVLO) Protection
- Soft Start Function that Minimizes Rush Current during Startup
- Adjustable Switching Frequency ($f = 200 \text{ kHz to } 600 \text{ kHz}$)
- Built-in Output Discharge Function
- Tracking Function
- Integrated Bootstrap Diode

Key Specification

- Input Voltage Range: 4.5V to 28V
- Output Voltage Range: 0.7V to 5.0V
- Output Current: 3.0A(Max)
- High Side ON-Resistance: 120mΩ(Typ)
- Low Side ON-Resistance: 120mΩ(Typ)
- Standby Current: 0μA (Typ)
- Operating Temperature Range: -10°C to +100°C

Package

W (Typ) x D (Typ) x H (Max)

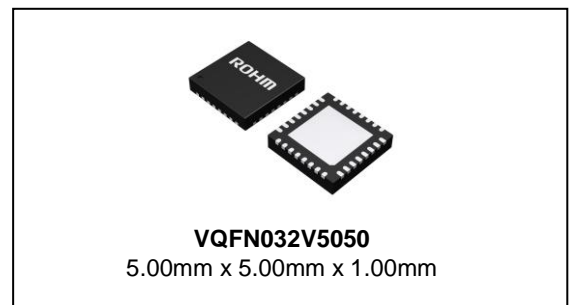

Application

Mobile PC, Desktop PC, LCD-TV, Digital Household Electronics

Typical Application Circuit

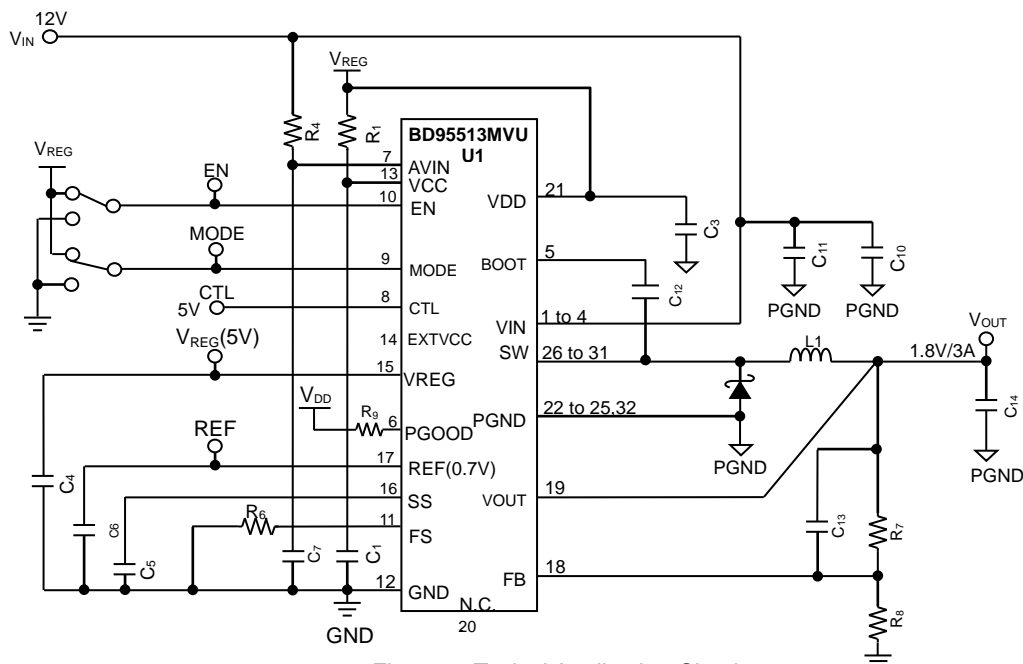
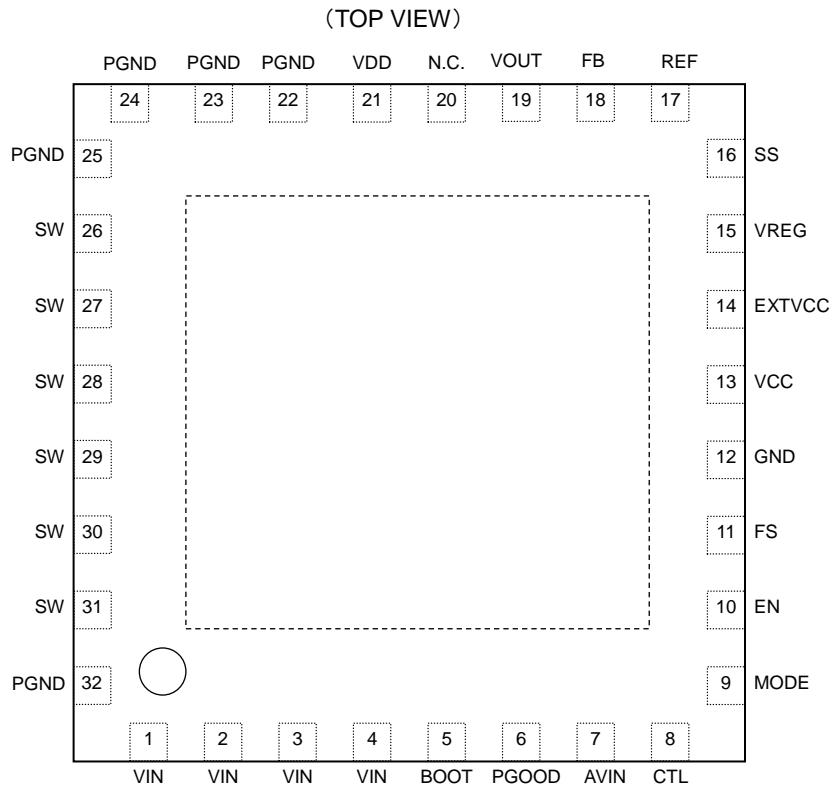

Figure 1. Typical Application Circuit

Pin Configuration



Note: Connect the underside (FIN) to the ground terminal

Figure. 2 Pin Configuration

Pin Description

(Function Table)

Pin No.	Pin Name	Pin Description
1 to 4	VIN	Battery voltage input (4.5V to 28 V)
5	BOOT	HG driver power supply
6	PGOOD	Power good output (high when output $\pm 10\%$ of regulation)
7	AVIN	Battery voltage sense
8	CTL	Linear regulator on/off (high = 5.0V, low = OFF)
9	MODE	Control mode selection GND : Continuous Mode 3.0V : QLLM VCC : SLLM™
10	EN	Enable output (high when VOUT ON)
11	FS	Switching frequency adjustment ($R_{FS} = 30k\Omega$ to $100k\Omega$)
12	GND	Sense ground
13	VCC	Power supply input
14	EXTVCC	External power supply input
15	VREG	IC reference voltage (5.0V / 200mA)
16	SS	Soft start condenser input
17	REF	Output reference voltage (0.7V)
18	FB	Feedback input (0.7V)
19	VOUT	Voltage discharge output
20	N.C.	No Connect Pin
21	VDD	Power supply input (5V)
22 to 25	PGND	Power ground
26 to 31	SW	Output to inductor
32	PGND	Power ground
Underside	FIN	Substrate connection

Block Diagram

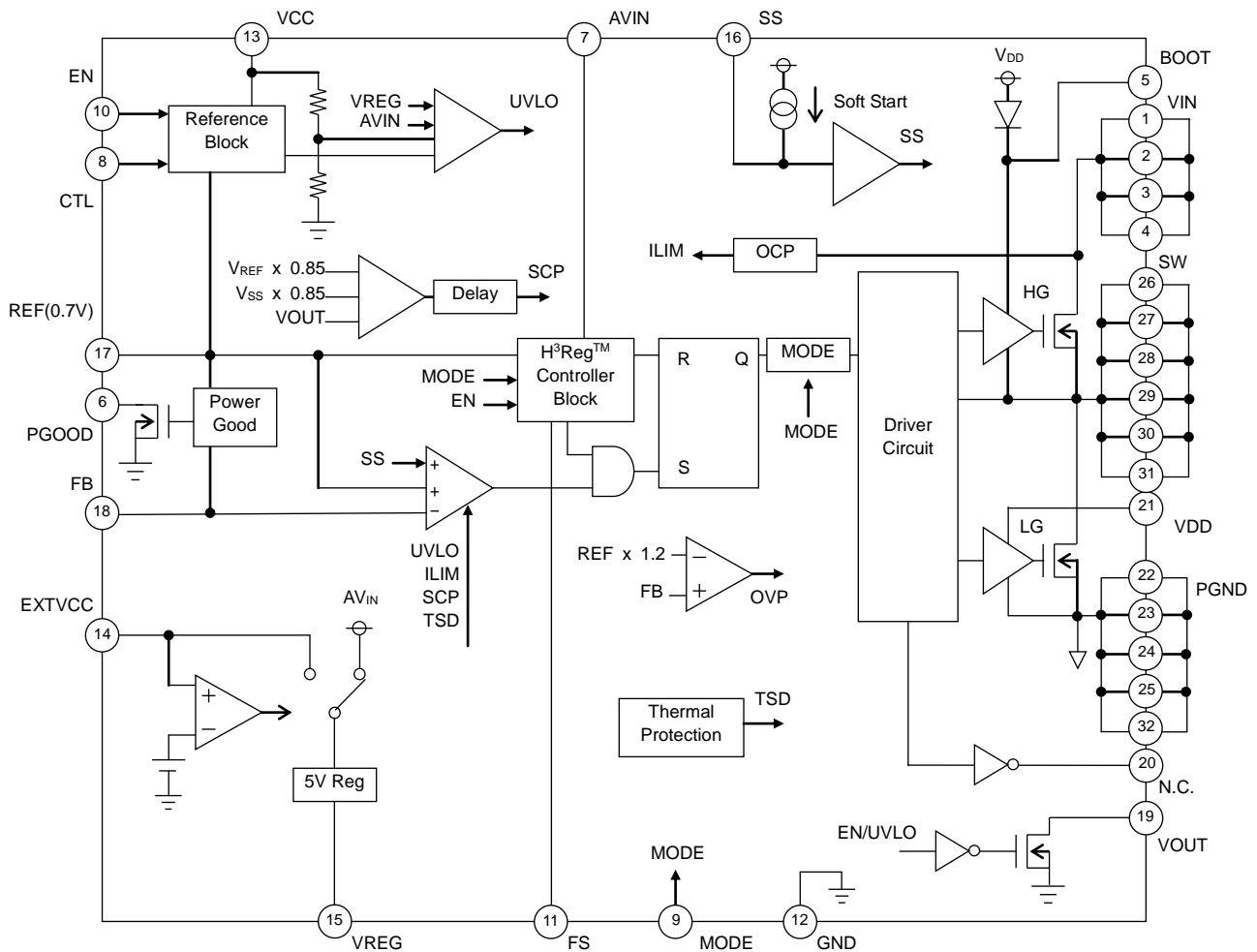

Figure 3. Block Diagram

Description of Blocks

1. VCC (Pin 13)
This is the power supply pin for the IC's internal circuits, except for the FET driver. Use by connecting it to VREG output. Using RC filter with 10Ω, 1μF(app.) for VCC pin is recommended.
2. EN (Pin 10)
This pin enables or disables the switching regulator. When the voltage on EN pin is at least 2.3V, the switching regulator is ON. Conversely, it is OFF when the voltage at EN pin is lower than 0.8V.
3. VDD (Pin 21)
This is the power supply pin that drives the LOW side FET and the bootstrap diode. It is recommended that a 1 μF to 10μF bypass capacitor be connected to compensate for rush current during the FET ON/OFF transition.
4. VREG (Pin 15)
Output pin of the 5V linear regulator. This pin also supplies power to the internal driver and control circuitry. VREG standby function is controlled by the CTL pin. The output supplies 5V at 100 mA and should be bypassed to ground using a 10 μF capacitor with a rating of X5R or X7R.
5. EXTVCC (Pin 14)
External power supply input for the linear regulator. When the voltage on the EXTVCC pin exceeds 4.4V, the regulator uses it in conjunction with other power sources to supply VREG. Leave the EXTVCC pin floating when not in use.
6. REF (Pin 17)
Reference voltage output pin. The reference voltage is set internally by the IC to 0.7V, and the IC works to keep VREF approximately equal to VFB. Variations in voltage levels on this pin affect the output voltage, so the pin should be bypassed with a 100pF to 0.1μF ceramic capacitor.

Description of Blocks – continued

7. SS (Pin 16)
Soft start/stop pin. When EN is set to high, the capacitor between the internal current source and SS-GND controls the startup time of the IC. When the voltage on the SS pin is lower than the REF output voltage (0.7V), the output voltage is held at the same voltage as the SS pin.
8. AVIN (Pin 7)
The BD95513MUV controls the duty cycle and output voltage based on the input voltage at this pin, so voltage variations or oscillations on this line can cause unstable operation. This pin also acts as the voltage input for the switching block, so insufficient coupling impedance can also cause unstable operation. Therefore, this line should be bypassed with either a power capacitor or RC filter.
9. FS (Pin 11)
Frequency-adjusting resistance input pin. Attaching a resistance of 30 kΩ to 100 kΩ adjusts the switching frequency from 200 kHz to 600kHz.
10. BOOT (Pin 5)
This pin serves as the power source for the high side of the FET driver. A bootstrap diode is integrated within the IC. The maximum voltage on this pin should not exceed +35V with reference to GND or +7V with reference to SW. When operating the switching regulator, the operation of the bootstrap circuitry causes the BOOT voltage to swing from ($V_{IN} + V_{DD}$) to V_{DD} .
11. PGOOD (Pin 6)
Power good indicator. This open-drain output should be connected to a power supply via a 100 kΩ pull-up resistor.
12. MODE (Pin 9)
Mode selection pin. When low, the IC functions in forced-continuous mode; at voltages from 0V to 3V, QLLM mode; when high, SLLM™ mode.
13. CTL (Pin 8)
Linear regulator control pin. When voltage is 2.3V or higher, a logic HIGH is recognized and the internal regulator ($V_{REG} = 5V$) is switched ON. At voltages of 0.8V or lower, a logic LOW is recognized and the regulator is switched OFF. However, even if EN is logic HIGH, the switching regulator will not operate if CTL is logic LOW.
14. FB (Pin 18)
Output voltage feedback input. V_{FB} is held at 0.7V by the IC.
15. SW (Pin 26 to 31)
Output from the switching regulator to the inductor. This output swings from V_{IN} to GND. The trace from the output to the inductor should be as short and wide as possible.
16. VOUT (Pin 19)
Voltage output discharge pin. When EN is off, this output is pulled to low.
17. VIN (Pin 1 to 4)
Power supply input. The IC can accept any input from 4.5V to 28V. This pin should be bypassed directly to ground by a power capacitor.
18. PGND (Pin 22 to 25, 32)
Power ground terminal.

Absolute Maximum Ratings (Ta = 25°C)

Parameter	Symbol	Rating	Unit
Input Voltage 1	V _{CC}	7 (Note 1)	V
Input Voltage 2	V _{DD}	7 (Note 1)	V
Input Voltage 3	AV _{IN}	30 (Note 1)	V
Input Voltage 4	V _{IN}	30 (Note 1)	V
External VCC Voltage	EXTV _{CC}	7 (Note 1)	V
BOOT Voltage	V _{BOOT}	35	V
BOOT-SW Voltage	V _{BOOT-SW}	7 (Note 1)	V
Output Feedback Voltage	V _{FB}	V _{CC}	V
SS/FS/MODE Voltage	V _{SS} /V _{FS} /V _{MODE}	V _{CC}	V
VREG Voltage	V _{REG}	V _{CC}	V
EN/CTL Input Voltage	V _{EN} /V _{CTL}	7 (Note 1)	V
PGOOD Voltage	V _{PGOOD}	7 (Note 1)	V
Output Current (Average)	I _{SW}	3 (Note 1)	A
Power Dissipation 1	Pd1	0.38 (Note 2)	W
Power Dissipation 2	Pd2	0.88 (Note 3 and Note 6)	W
Power Dissipation 3	Pd3	3.26 (Note 4 and Note 6)	W
Power Dissipation 4	Pd4	4.56 (Note 5 and Note 6)	W
Operating Temperature Range	T _{opr}	-10 to +100	°C
Storage Temperature Range	T _{stg}	-55 to +150	°C
Junction Temperature	T _{jmax}	+150	°C

(Note 1) Should not exceed Pd.

(Note 2) Ta ≥ 25°C (IC only),

Power dissipated at 3.0 mW/°C.

(Note 3) Ta ≥ 25°C (single-layer board, 20.2 mm² copper heat dissipation pad),

Power dissipated at 7.0 mW/°C.

(Note 4) Ta ≥ 25°C (4-layer board, 20.2 mm² copper heat dissipation pad on top layer, 5505 mm² pad on 2nd and 3rd layer),

Power dissipated at 26.1 mW/°C.

(Note 5) Ta ≥ 25°C (4-layer board, all layers with 5505 mm² copper heat dissipation pads),

Power dissipated at 36.5 mW/°C.

(Note 6) Values observed with chip backside soldered. When unsoldered, power dissipation is lower.

Caution: Operating the IC over the absolute maximum ratings may damage the IC. The damage can either be a short circuit between pins or an open circuit between pins and internal circuitry. Therefore, it is important to consider circuit protection measures, such as adding a fuse, in case the IC is operated over the absolute maximum ratings.

Recommended Operating Conditions (Ta = 25°C)

Parameter	Symbol	Rating		Unit
		Min	Max	
Input Voltage 1	V _{CC}	4.5	5.5	V
Input Voltage 2	V _{DD}	4.5	5.5	V
Input Voltage 3	AV _{IN}	4.5	28	V
Input Voltage 4	V _{IN}	4.5	28	V
External VCC Voltage	EXTV _{CC}	4.5	5.5	V
BOOT Voltage	V _{BOOT}	4.5	33	V
SW Voltage	V _{SW}	-0.7	+28	V
BOOT-SW Voltage	V _{BOOT-SW}	4.5	5.5	V
MODE Input Voltage	V _{MODE}	0	5.5	V
EN/CTL Input Voltage	V _{EN} /V _{CTL}	0	5.5	V
PGOOD Voltage	V _{PGOOD}	0	5.5	V
Minimum On Time	t _{ON_MIN}	-	100	ns

Electrical Characteristics

(Unless otherwise noted, Ta=25°C, AVIN=12V, VCC=VDD=VREG, VEN/VCTL=5V, VMODE=0V, RFS=180kΩ)

Parameter	Symbol	Limit			Unit	Conditions
		Min	Typ	Max		
[Whole Device]						
AVIN Bias Current 1	IIN1	-	1200	1800	μA	
AVIN Bias Current 2	IIN2	-	150	250	μA	EXTVCC=5V
AVIN Standby Current	IINSTB	-	0	10	μA	VCTL=VEN=0V
EN Low Voltage	VENLOW	GND	-	0.8	V	
EN High Voltage	VENHIGH	2.3	-	5.5	V	
EN Bias Voltage	IEN	-	12	20	μA	
CTL Low Voltage	VCTLOW	GND	-	0.8	V	
CTL High Voltage	VCTHIGH	2.3	-	5.5	V	
CTL Bias Current	ICTL	-	1	6	μA	
[5V Regulator]						
VREG Input Voltage	VREG	4.90	5.00	5.10	V	AVIN=6.0V to 25V IREG=0 to 100mA
Maximum Current	IREG	100	-	-	mA	
[5V Switch]						
EXTVCC Input Threshold Voltage	EVCC_UVLO	4.2	4.4	4.6	V	EXTVCC: Sweep up
Switch Resistance	REVCC	-	1.0	2.0	Ω	
[Under-Voltage Lockout Protection]						
AVIN Threshold Voltage	AVIN_UVLO	4.1	4.3	4.5	V	VCC: Sweep up
AVIN Hysteresis Voltage	dAVIN_UVLO	100	160	220	mV	VCC: Sweep down
VREG Threshold Voltage	VREG_UVLO	4.1	4.3	4.5	V	VREG: Sweep up
VREG Hysteresis Voltage	dVREG_UVLO	100	160	220	mV	VREG: Sweep down
[H ³ Reg™ Control Block]						
ON Time	ton	400	500	600	nsec	
MAX ON Time	tonMAX	10.0	22.0	40.0	μsec	
MIN OFF Time	toffMIN	-	450	550	nsec	
[FET Block]						
High Side ON-Resistance	RON_HIGH	-	120	200	mΩ	
Low Side ON-Resistance	RON_LOW	-	120	200	mΩ	
[SCP Block]						
SCP Startup Voltage	VSCP	0.420	0.490	0.560	V	When VFB: 30% down
Delay	tSCP	0.5	1	2	ms	

Electrical Characteristics - continued

(Unless otherwise noted, Ta=25°C, AVIN=12V, VCC=VDD=VREG, VEN/VCTL=5V, VMODE=0V, RFS=180kΩ)

Parameter	Symbol	Limit			Unit	Conditions
		Min	Typ	Max		
[Over-Voltage Protection Block]						
OVP Detect Voltage	V _{OVP}	0.800	0.840	0.880	V	When V _{FB} : 20% up
[Soft Start Block]						
Charge Current	I _{SS}	1.4	2.2	3.0	μA	
Standby Voltage	V _{SS_STB}	-	-	100	mV	
[Current Regulation Block]						
Maximum Output Current	I _{OC}	3	-	-	A	
[Voltage Detection Block]						
Feedback Terminal Voltage 1	V _{FB1}	0.693	0.700	0.707	V	
Feedback Terminal Voltage 2	V _{FB2}	0.690	0.700	0.710	V	Ta = -10°C to +100°C I _{OUT} = 0A to 3A
Feedback Terminal Bias Current	I _{FB}	-100	0	+100	nA	
[MODE Block]						
SLLM™ Condition	V _{THSLLM}	V _{CC} -0.5	-	V _{CC}	V	SLLM™ Longest low-gate off time: ∞
Forced Continuous Mode	V _{THCONT}	GND	-	0.5	V	Continuous mode
Open Voltage	V _{MODE}	1.5	-	3.0	V	
[Power Good Block]						
VFB Power Good Low Voltage	V _{FBPL}	0.605	0.63	0.655	V	When V _{FB} : 10% down
VFB Power Good High Voltage	V _{FBPH}	0.745	0.77	0.795	V	When V _{FB} : 10% up

Typical Performance Curves

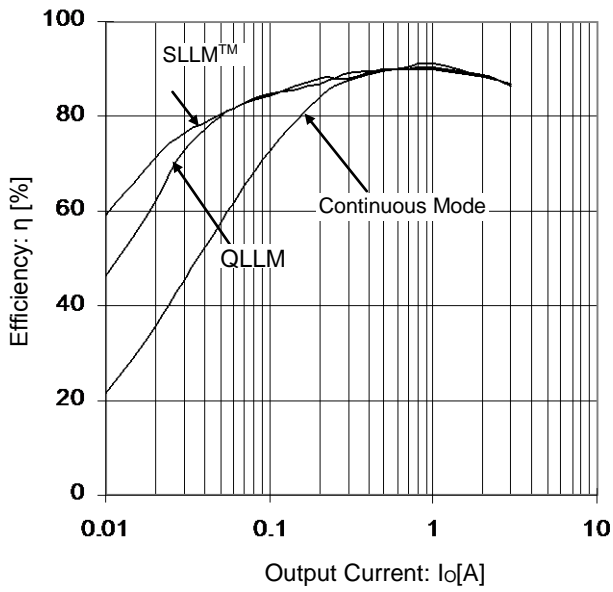

Figure 4. Efficiency vs Output Current (VIN=7V, VOUT=2.5V)

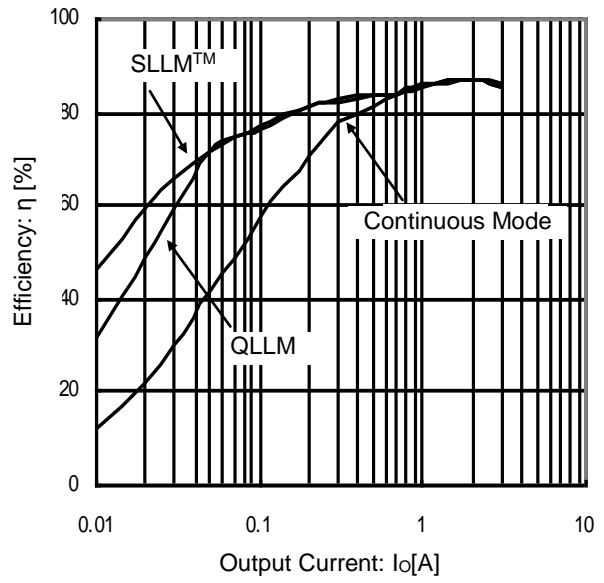

Figure 5. Efficiency vs Output Current (VIN=12V, VOUT=2.5V)

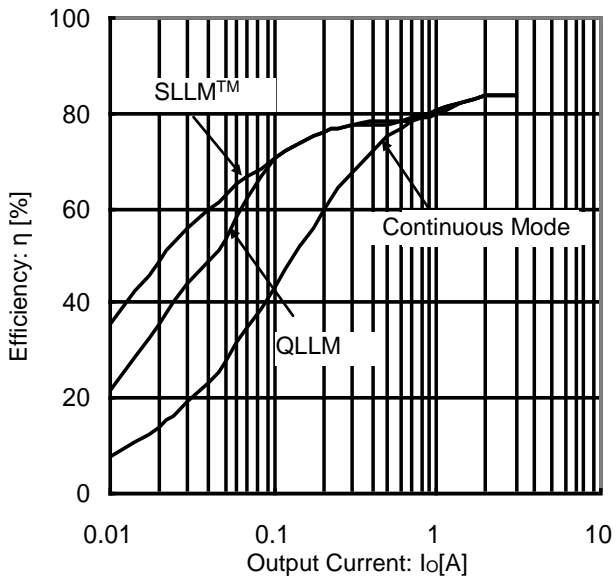

Figure 6. Efficiency vs Output Current (VIN=19V, VOUT=2.5V)

Typical Waveforms

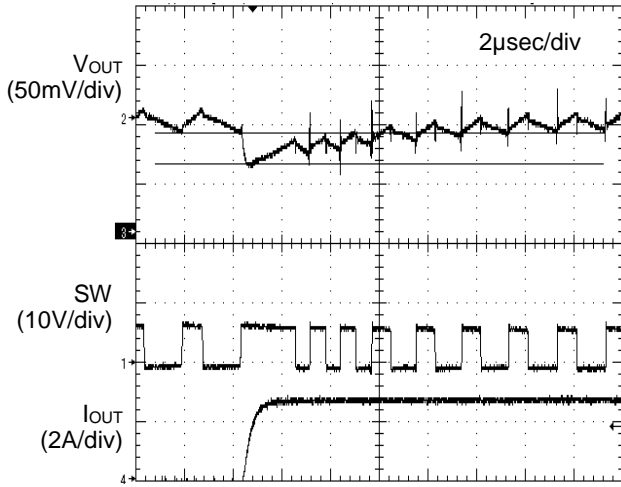

Figure 7. Transient Response
($V_{IN}=7V$, $V_{OUT}=2.5V$)

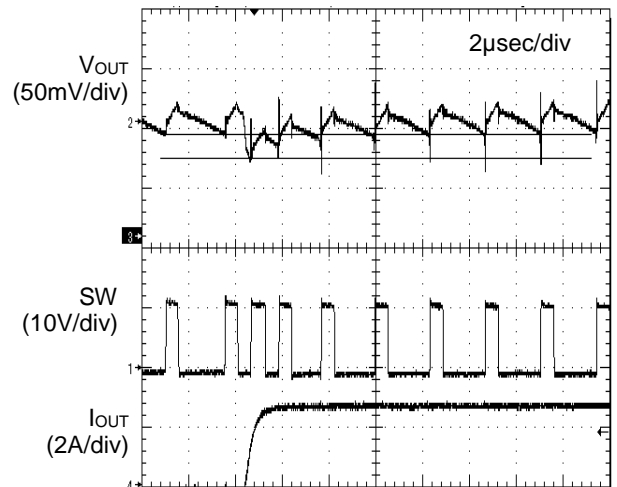

Figure 8. Transient Response
($V_{IN}=12V$, $V_{OUT}=2.5V$)

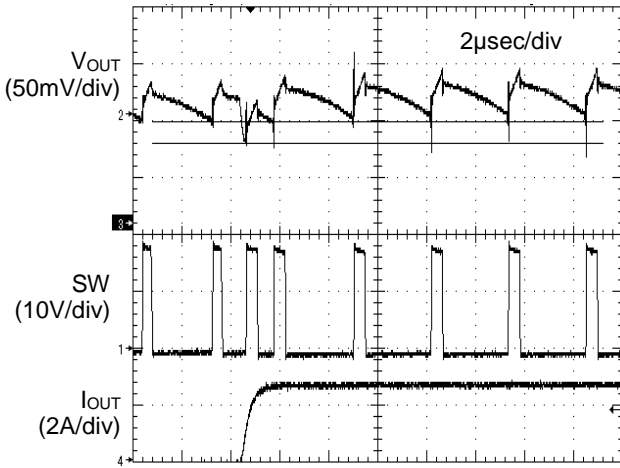

Figure 9. Transient Response
($V_{IN}=19V$, $V_{OUT}=2.5V$)

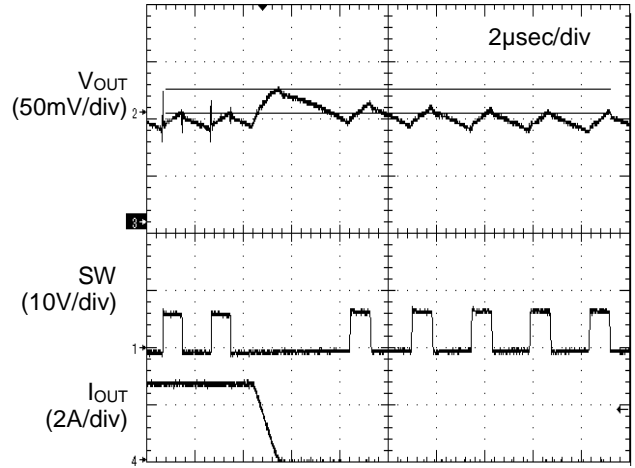

Figure 10. Transient Response
($V_{IN}=7V$, $V_{OUT}=2.5V$)

Typical Waveforms - continued

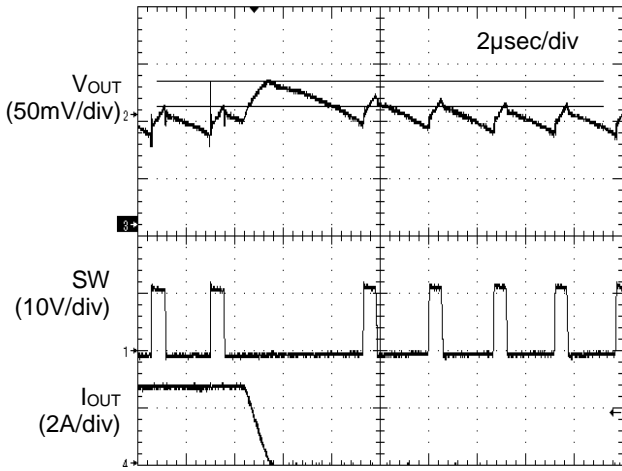

Figure 11. Transient Response
($V_{IN}=12V$, $V_{OUT}=2.5V$)

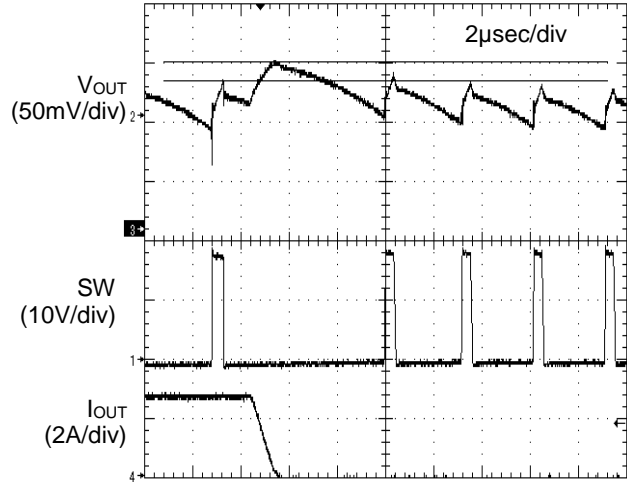

Figure 12. Transient Response
($V_{IN}=19V$, $V_{OUT}=2.5V$)

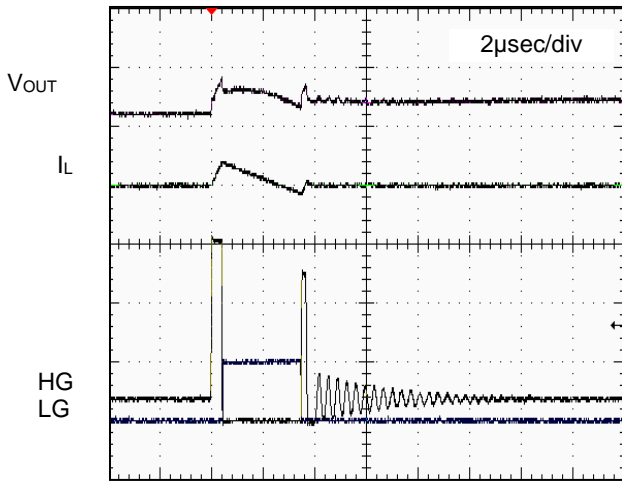

Figure 13. SLLM™ Mode
($I_{OUT}=0A$)

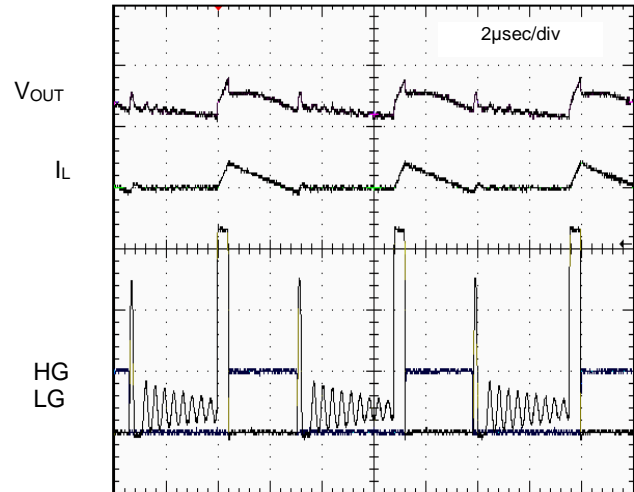

Figure 14. SLLM™ Mode
($I_{OUT}=0.4A$)

Typical Waveforms - continued

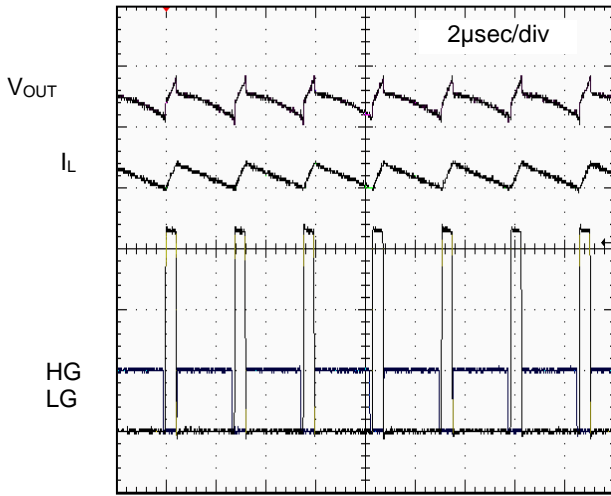

Figure 15. 1 SLLM™ Mode
(I_{OUT} = 1A)

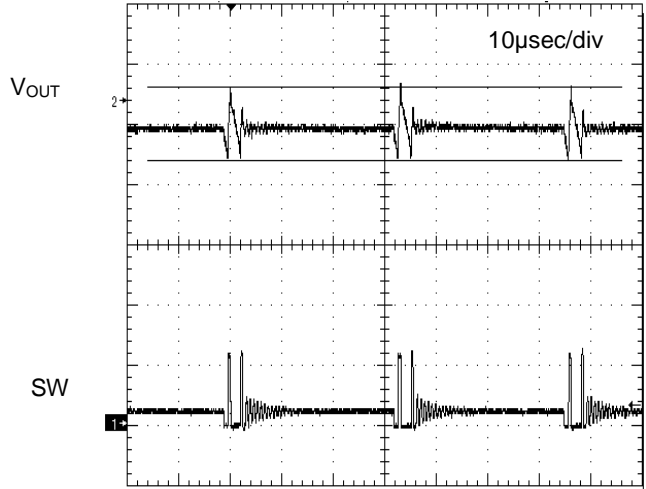

Figure 16. QLLM Mode
(I_{OUT} = 0A)

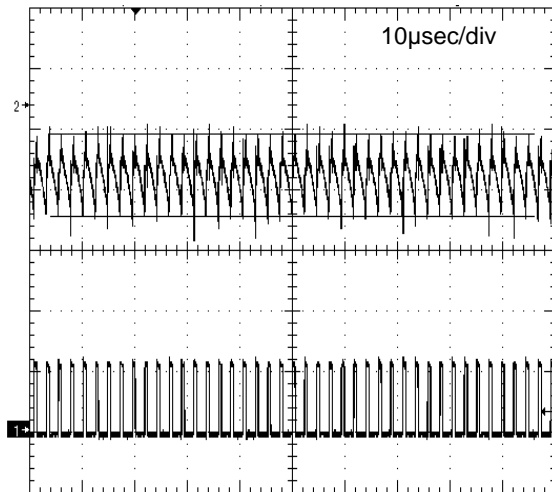

Figure 17. QLLM Mode
(I_{OUT} = 1A)

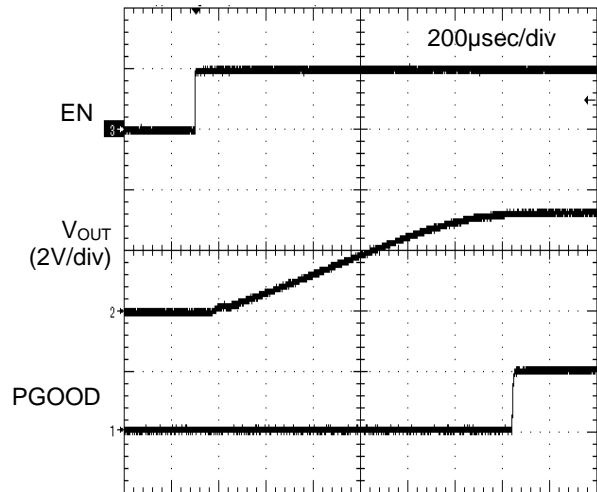

Figure 18. PGOOD Rising Waveform

Typical Waveforms - continued

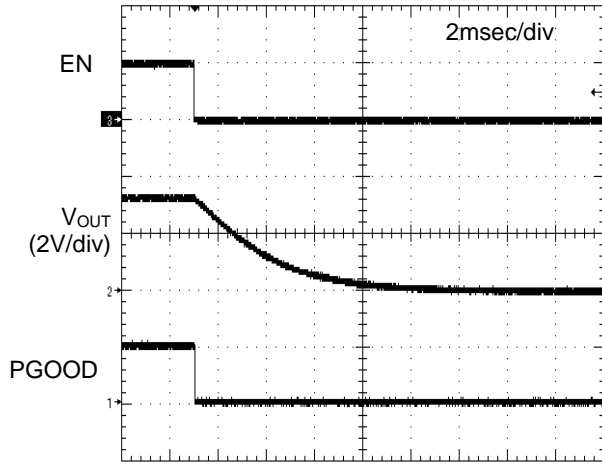

Figure 19. PGOOD Falling Waveform

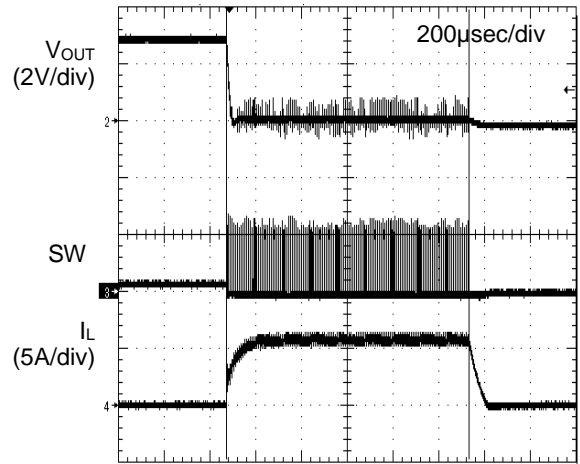

Figure 20. SCP Timer Latch Waveform

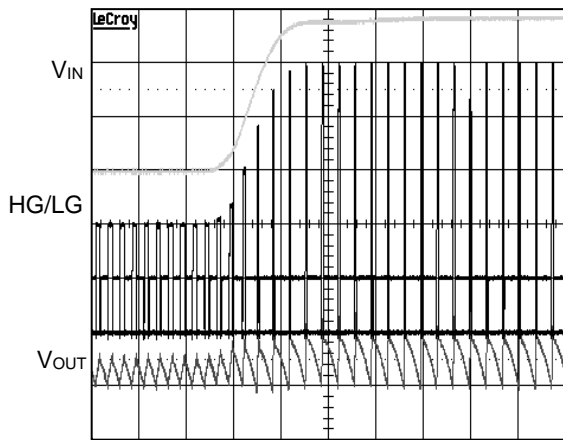

Figure 21. VIN Change (5V → 19V)

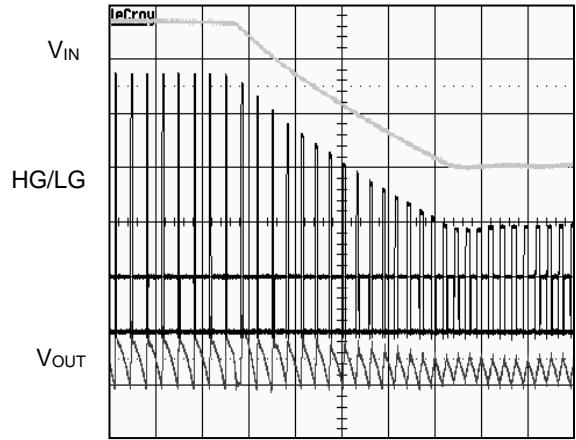

Figure 22. VIN Change (19V → 5V)

Typical Waveforms - continued

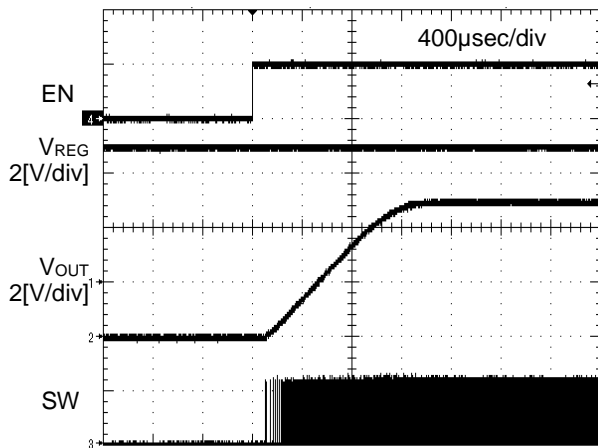

Figure 23. EN Wake Up

Application Information

1. Explanation of Operation

The BD95513MUV is a switching regulator incorporating ROHM's proprietary H³Reg™ CONTROLLA control system. When V_{OUT} drops suddenly due to changes in load, the system quickly restores the output voltage by extending the t_{ON} time interval. This improves the regulator's transient response. When light-load mode is activated, the IC employs the Simple Light Load Mode (SLLM™) controller, further improving system efficiency.

H³Reg™ Control
(Normal Operation)

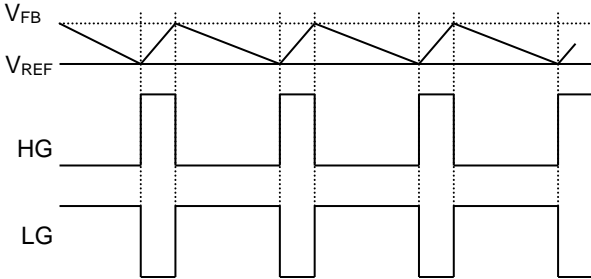

When V_{FB} falls below the reference voltage (0.7V), the H³Reg™ CONTROLLA is activated;

$$t_{ON} = \frac{V_{REF}}{V_{IN}} \times \frac{1}{f} \quad [\text{sec}] \quad (1)$$

High gate output is determined by the above formula.

(Rapid Changes in Load)

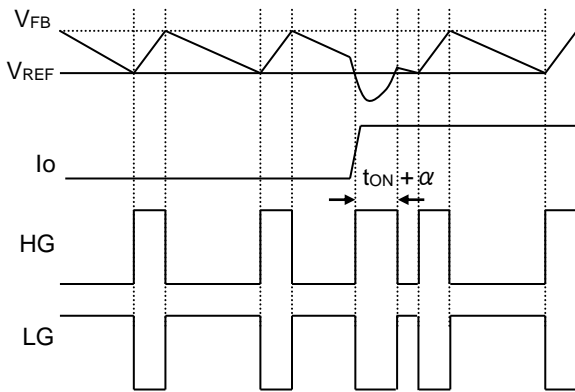

When V_{OUT} drops due to a sudden change in load and the voltage remains below V_{REF} after the preprogrammed t_{ON} time interval has elapsed, the system quickly restores V_{OUT} by extending the t_{ON} time, thereby improving transient response.

Light Load Control
(SLLM™ Mode)

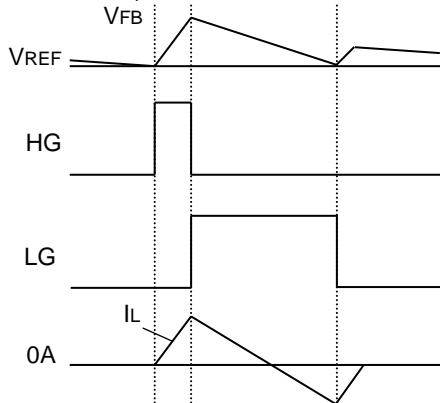

SLLM™ mode is enabled by setting the MODE pin to logic high. When the low gate is off and the current through the inductor is 0 (current flowing from V_{OUT} to SW), the SLLM™ function is activated, disabling high gate output.

If V_{FB} falls below V_{REF} again, the high gate is switched back on, lowering the switching frequency of the regulator and yielding higher efficiency when powering light loads.

(QLLM Mode)

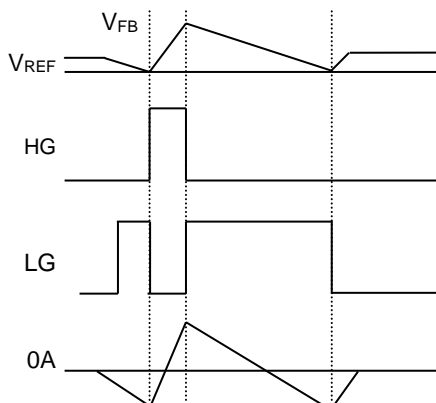

QLLM mode is enabled by setting the MODE pin to Hi-Z or middle voltage. When the lower gate is off and the current through the inductor is 0 (current flowing from V_{OUT} to SW), QLLM mode is activated, disabling high gate output.

If V_{FB} falls below V_{REF} within a programmed time interval (typ 40 μsec), the high gate is switched on, but if V_{FB} does not fall below V_{REF}, the lower gate is forced on, dropping V_{FB} and switching the high gate back on.

The minimum switching frequency is set to 25 kHz (T=40μsec), which keeps the regulator's frequency from entering the audible spectrum but yields less efficient results than SLLM™ mode.

2. Timing Chart

(1) Soft Start Function

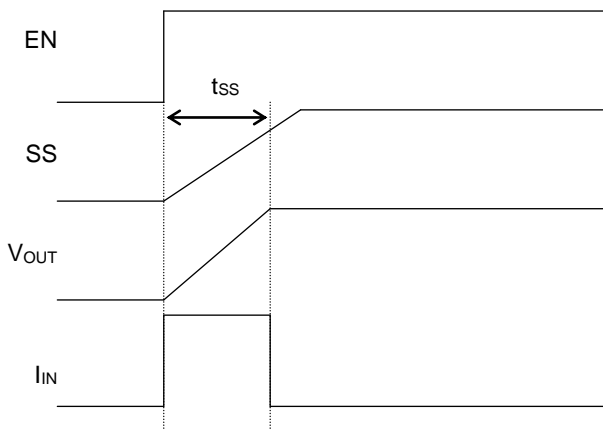

The soft start function is enabled when the EN pin is set to high. Current control circuitry takes effect at startup, yielding a moderate “ramping start” in output voltage. Soft start timing and incoming current are given by equation (2) and (3) below:

Soft start period:

$$t_{SS} = \frac{0.7(V) \times C_{SS}}{2.2\mu A(typ)} \quad [sec] \quad (2)$$

Rush current:

$$I_{IN(ON)} = \frac{C_O \times V_{OUT}}{t_{SS}} \quad [A] \quad (3)$$

Where:

C_{SS} is the soft start capacitor

C_O is the output capacitor.

(2) Timer Latch-type Short Circuit Protection

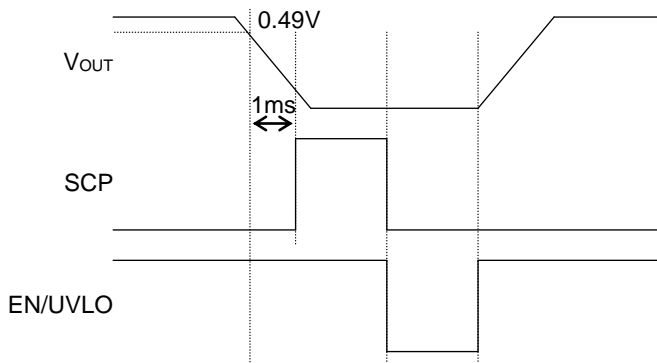

When output voltage falls to $V_{REF} \times 0.70$ ($V_{FB} \leq 0.49V$) or less, the output short circuit protection is triggered, turning the IC off after a set period of time to prevent internal damage. When EN is switched back on or when UVLO is cleared, output continues. The time period before shutting off is set internally at 1ms.

(3) Output Over-Voltage Protection

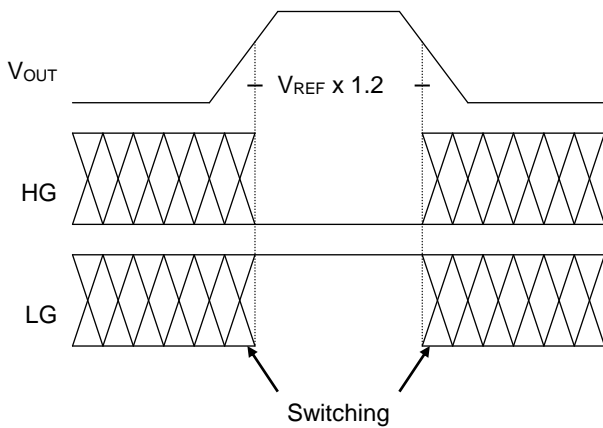

When output reaches or exceeds $V_{REF} \times 1.2$ ($V_{FB} \geq 0.84V$), the output over-voltage protection is triggered, turning the low-side FET completely on to reduce the output (low gate on, high gate OFF). When the output falls, it returns to standard mode.

3. External Component Selection

(1) Inductor (L) Selection

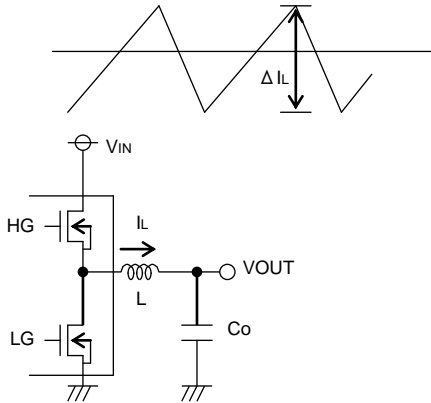

Output ripple current

The inductor's value directly influences the output ripple current. As indicated by equation (4) below, the greater the inductance or switching frequency, the lower the ripple current:

$$\Delta I_L = \frac{(V_{IN} - V_{OUT}) \times V_{OUT}}{L \times V_{IN} \times f} \quad [A] \quad (4)$$

The proper output ripple current setting is about 30% of maximum output current.

$$\Delta I_L = 0.3 \times I_{OUT\ max} \quad [A] \quad (5)$$

$$L = \frac{(V_{IN} - V_{OUT}) \times V_{OUT}}{\Delta I_L \times V_{IN} \times f} \quad [H] \quad (6)$$

Where:

ΔI_L is the output ripple current and f is the switching frequency

- (a) Passing a current larger than the inductor's rated current will cause magnetic saturation in the inductor and decrease system efficiency. In selecting the inductor, be sure to allow enough margin to assure that peak current does not exceed the inductor's rated current value.
- (b) To minimize possible inductor damage and maximize efficiency, choose an inductor with a low DCR and ACR resistance.

(2) Output Capacitor Selection (Co)

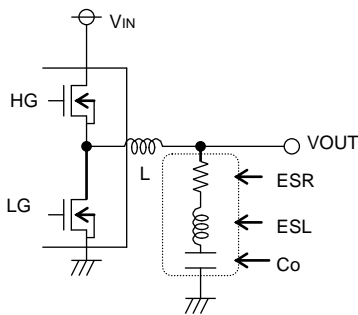

Output Capacitor

When determining the proper output capacitor, be sure to consider the equivalent series resistance (ESR) and equivalent series inductance (ESL) required to set the output ripple voltage to 20 mV or more.

When selecting the limit of the inductor, be sure to allow enough margin for the output voltage. Output ripple voltage is determined by equation (7) below:

$$\Delta V_{OUT} = \Delta I_L \times ESR + ESL \times \Delta I_L / T_{ON} \quad (7)$$

Where:

ΔI_L is the output ripple current

ESR is the equivalent series resistance

ESL is the equivalent series inductance

Give special consideration to the conditions of equation (8) for output capacitance. Also, keep in mind that the output rise time must be established within the soft start timeframe.

$$C_{O} \leq \frac{t_{SS} \times (I_{limit} - I_{OUT})}{V_{OUT}} \quad (8)$$

Where:

t_{SS} is the Soft start timeframe (see p. 15, equation (2))

I_{limit} is the Maximum output current.)

I_{OUT} is the load current

Choosing a capacitance that is too large can cause startup malfunctions, or in some cases, may trigger the short circuit protection.

(3) Input Capacitor Selection (CIN)

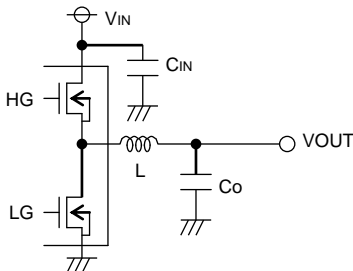

Input Capacitor

In order to prevent extreme over-current conditions, the input capacitor must have a low enough ESR to fully support a large ripple in the output. The formula for RMS ripple current (I_{RMS}) is given by equation (9) below:

$$I_{RMS} = I_{OUT} \times \frac{\sqrt{V_{IN} (V_{IN} - V_{OUT})}}{V_{IN}} \quad [A] \quad (9)$$

When $V_{IN} = 2 \times V_{OUT}$, $I_{RMS} = \frac{I_{OUT}}{2}$

A low-ESR capacitor is recommended to reduce ESR loss and maximize efficiency.

External Component Selection – continued

(4) Frequency Adjustment

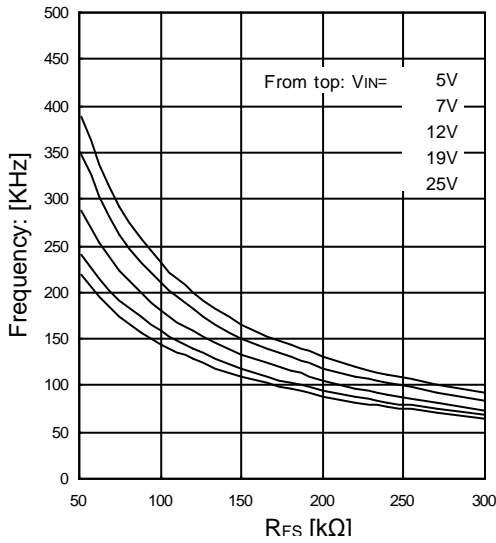

The resistance connected to the FS terminal adjusts the on-time (t_{ON}) during normal operation as illustrated on the left. When t_{ON}, input voltage and V_{REF} voltage are known, the switching frequency can be determined by the following equation:

$$F = \frac{V_{REF}}{V_{IN} \times t_{ON}} \quad (10)$$

However, real-life considerations (such as external MOSFET gate capacitance and switching time) must be factored in as they affect the overall switching rise and fall time. This leads to an increase in t_{ON}, lowering the total frequency slightly.

Additionally, when output current is around 0A in continuous mode, this “dead time” also has an effect upon on t_{ON}, further lowering the switching frequency. Confirm the switching frequency by measuring the current through the coil (at the point where current does not flow backwards) during normal operation.

The BD95513MUV operates by feeding the output voltage back through a resistive voltage divider. The output voltage is set by the following equation (see schematic below):

$$\text{Output Voltage} = \frac{R_1 + R_2}{R_2} \times V_{REF}(0.7V) + \frac{1}{2} \Delta I_L \times ESR \quad (11)$$

The switching frequency is also amplified by the same resistive voltage divider network:

$$f_{SW} = \frac{R_1 + R_2}{R_2} \times (\text{frequency set by } R_{FS}) \quad [\text{Hz}] \quad (12)$$

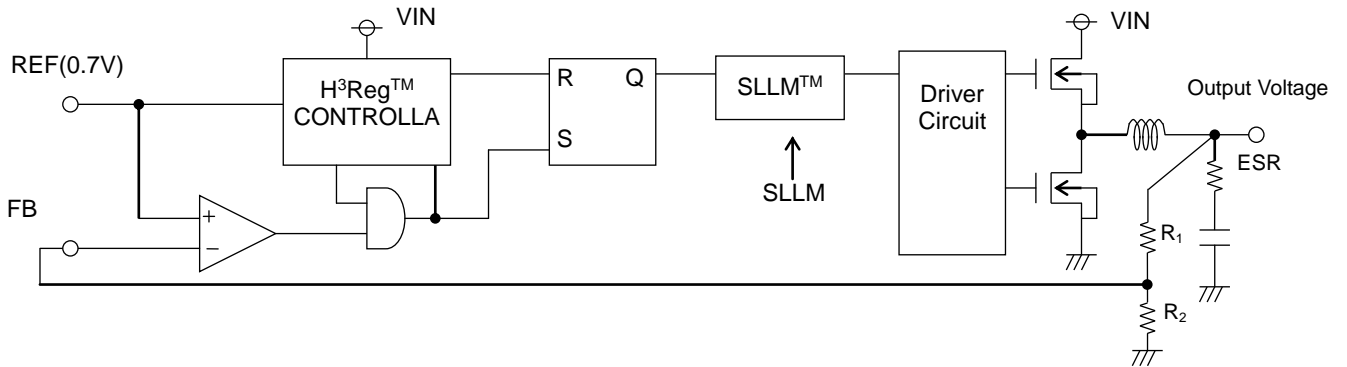

4. Evaluation Board Circuit (Frequency=300kHz Continuous Mode/QLLM/SLLM™ Sample Circuit)

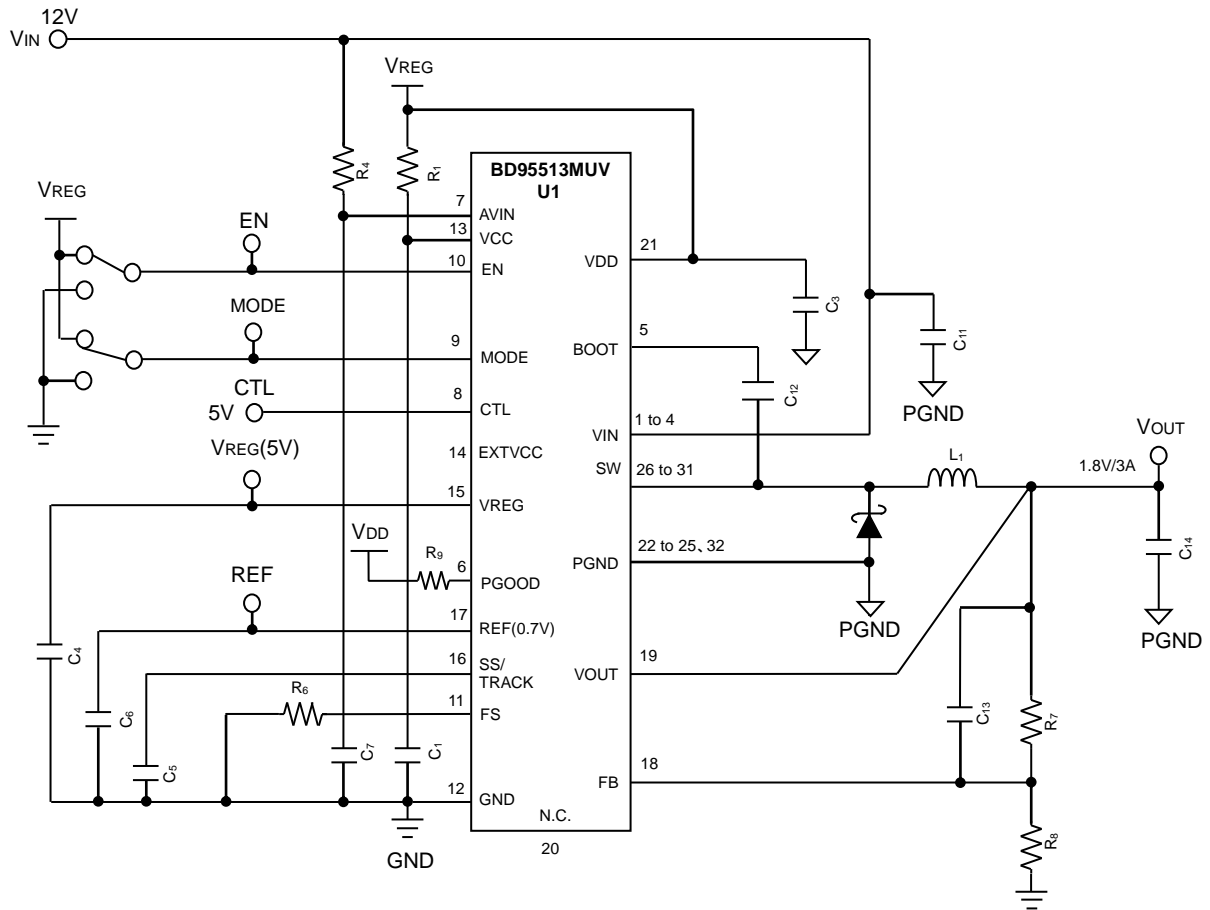

5. Evaluation Board Parts List

Part No.	Value	Company	Part Name	Part No.	Value	Company	Part Name
U1		ROHM	BD95513MUV	R1	10Ω	ROHM	MCR03
D1		ROHM	RB051L-40	R4	10Ω	ROHM	MCR03
C1	1μF	KYOCERA	CM105B105K06A	R6	180KΩ	ROHM	MCR03
C3	1μF	KYOCERA	CM105B105K16A	R7	31kΩ	ROHM	MCR03
C4	10μF	KYOCERA	CM316B106K06A	R8	20kΩ	ROHM	MCR03
C5	1000pF	MURATA	GRM39X7R102K50	R9	100kΩ	ROHM	MCR03
C6	0.1μF	KYOCERA	CM105B104K06A	L1	1.8μH	SUMIDA	CDEP104-1R8ML
C7	1μF	KYOCERA	CM105B105K16A	C14	470μF	SANYO	2R5TPE470ML
C11	10μF	KYOCERA	CM316B106M16A				
C12	0.1μF	KYOCERA	CM05B104K25A				
C13	220pF	MURATA	GRM39C0G221J50				

Power Dissipation

VQFN032V5050

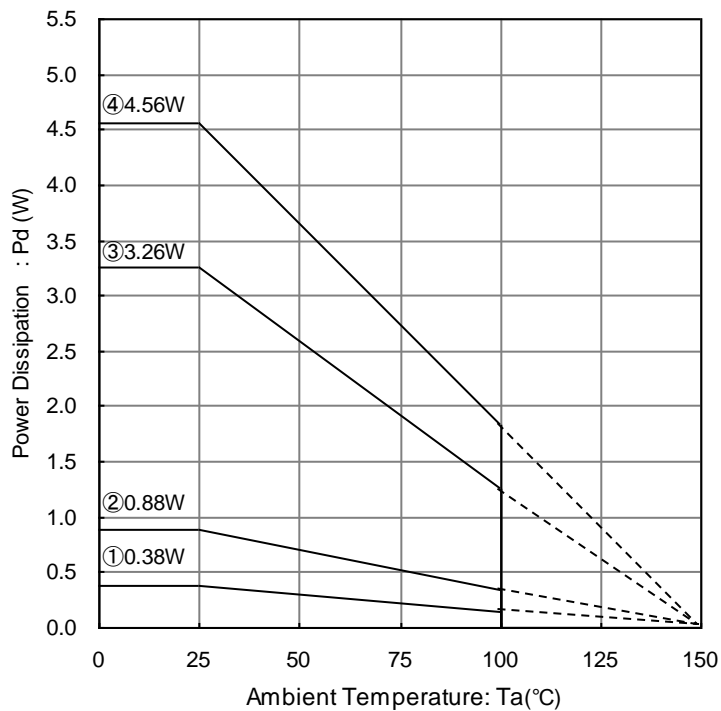

① IC Only

 $\theta_{j-a} = 328.9 \text{ } ^\circ\text{C/W}$ ② IC mounted on 1-layer board (with 20.2 mm² copper thermal pad) $\theta_{j-a} = 142.0 \text{ } ^\circ\text{C/W}$ ③ IC mounted on 4-layer board (with 20.2 mm² pad on top layer, 5505 mm² pad on layers 2,3) $\theta_{j-a} = 38.3 \text{ } ^\circ\text{C/W}$ ④ IC mounted on 4-layer board (with 5505mm² pad on all layers) $\theta_{j-a} = 27.4 \text{ } ^\circ\text{C/W}$

Operational Notes

1. Reverse Connection of Power Supply

Connecting the power supply in reverse polarity can damage the IC. Take precautions against reverse polarity when connecting the power supply, such as mounting an external diode between the power supply and the IC's power supply pins.

2. Power Supply Lines

Design the PCB layout pattern to provide low impedance supply lines. Separate the ground and supply lines of the digital and analog blocks to prevent noise in the ground and supply lines of the digital block from affecting the analog block. Furthermore, connect a capacitor to ground at all power supply pins. Consider the effect of temperature and aging on the capacitance value when using electrolytic capacitors.

3. Ground Voltage

Ensure that no pins are at a voltage below that of the ground pin at any time, even during transient condition.

4. Ground Wiring Pattern

When using both small-signal and large-current ground traces, the two ground traces should be routed separately but connected to a single ground at the reference point of the application board to avoid fluctuations in the small-signal ground caused by large currents. Also ensure that the ground traces of external components do not cause variations on the ground voltage. The ground lines must be as short and thick as possible to reduce line impedance.

5. Thermal Consideration

Should by any chance the power dissipation rating be exceeded the rise in temperature of the chip may result in deterioration of the properties of the chip. In case of exceeding this absolute maximum rating, increase the board size and copper area to prevent exceeding the Pd rating.

6. Recommended Operating Conditions

These conditions represent a range within which the expected characteristics of the IC can be approximately obtained. The electrical characteristics are guaranteed under the conditions of each parameter.

7. Inrush Current

When power is first supplied to the IC, it is possible that the internal logic may be unstable and inrush current may flow instantaneously due to the internal powering sequence and delays, especially if the IC has more than one power supply. Therefore, give special consideration to power coupling capacitance, power wiring, width of ground wiring, and routing of connections.

8. Operation Under Strong Electromagnetic Field

Operating the IC in the presence of a strong electromagnetic field may cause the IC to malfunction.

9. Testing on Application Boards

When testing the IC on an application board, connecting a capacitor directly to a low-impedance output pin may subject the IC to stress. Always discharge capacitors completely after each process or step. The IC's power supply should always be turned off completely before connecting or removing it from the test setup during the inspection process. To prevent damage from static discharge, ground the IC during assembly and use similar precautions during transport and storage.

10. Inter-pin Short and Mounting Errors

Ensure that the direction and position are correct when mounting the IC on the PCB. Incorrect mounting may result in damaging the IC. Avoid nearby pins being shorted to each other especially to ground, power supply and output pin. Inter-pin shorts could be due to many reasons such as metal particles, water droplets (in very humid environment) and unintentional solder bridge deposited in between pins during assembly to name a few.

Operational Notes – continued

11. Unused Input Pins

Input pins of an IC are often connected to the gate of a MOS transistor. The gate has extremely high impedance and extremely low capacitance. If left unconnected, the electric field from the outside can easily charge it. The small charge acquired in this way is enough to produce a significant effect on the conduction through the transistor and cause unexpected operation of the IC. So unless otherwise specified, unused input pins should be connected to the power supply or ground line.

12. Regarding the Input Pin of the IC

This monolithic IC contains P+ isolation and P substrate layers between adjacent elements in order to keep them isolated. P-N junctions are formed at the intersection of the P layers with the N layers of other elements, creating a parasitic diode or transistor. For example (refer to figure below):

When GND > Pin A and GND > Pin B, the P-N junction operates as a parasitic diode.
 When GND > Pin B, the P-N junction operates as a parasitic transistor.

Parasitic diodes inevitably occur in the structure of the IC. The operation of parasitic diodes can result in mutual interference among circuits, operational faults, or physical damage. Therefore, conditions that cause these diodes to operate, such as applying a voltage lower than the GND voltage to an input pin (and thus to the P substrate) should be avoided.

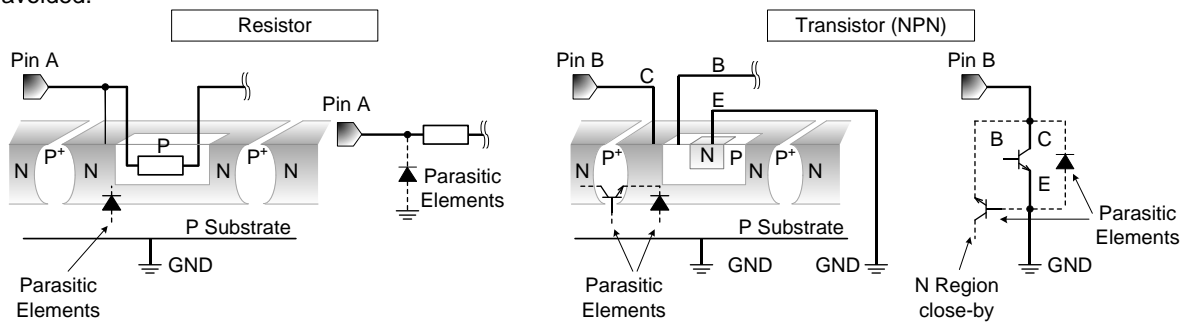

Figure 24. Example of monolithic IC structure

13. Area of Safe Operation (ASO)

Operate the IC such that the output voltage, output current, and power dissipation are all within the Area of Safe Operation (ASO).

14. Thermal Shutdown Circuit(TSD)

This IC has a built-in thermal shutdown circuit that prevents heat damage to the IC. Normal operation should always be within the IC's power dissipation rating. If however the rating is exceeded for a continued period, the junction temperature (Tj) will rise which will activate the TSD circuit that will turn OFF all output pins. When the Tj falls below the TSD threshold, the circuits are automatically restored to normal operation.

Note that the TSD circuit operates in a situation that exceeds the absolute maximum ratings and therefore, under no circumstances, should the TSD circuit be used in a set design or for any purpose other than protecting the IC from heat damage.

	TSD ON Temp. [°C] (typ)	Hysteresis Temp. [°C] (typ)
BD95513MUV	175	15

15. Ground wiring traces

When using both small-signal and large-current GND traces, the two ground traces should be routed separately but connected to a single ground potential within the application in order to avoid variations in the small-signal ground caused by large currents. Also ensure that the GND traces of external components do not cause variations on GND voltage.

Ordering Information

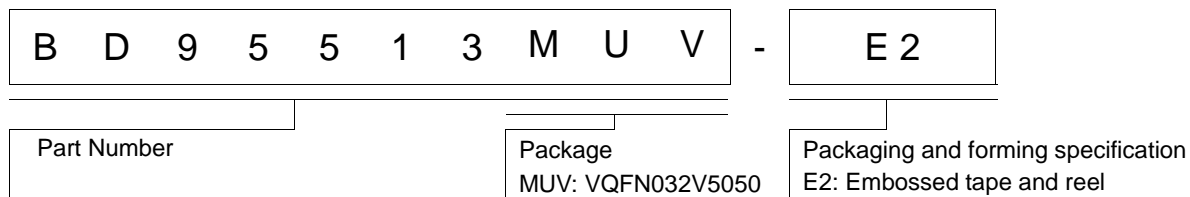

Marking Diagram

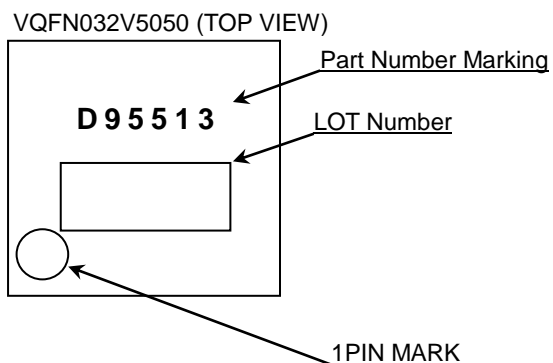

Revision History

Date	Revision	Changes
17.Nov.2014	001	New Release
02.Aug.2016	002	Modify some typo

Notice

Precaution on using ROHM Products

- Our Products are designed and manufactured for application in ordinary electronic equipments (such as AV equipment, OA equipment, telecommunication equipment, home electronic appliances, amusement equipment, etc.). If you intend to use our Products in devices requiring extremely high reliability (such as medical equipment ^(Note 1), transport equipment, traffic equipment, aircraft/spacecraft, nuclear power controllers, fuel controllers, car equipment including car accessories, safety devices, etc.) and whose malfunction or failure may cause loss of human life, bodily injury or serious damage to property ("Specific Applications"), please consult with the ROHM sales representative in advance. Unless otherwise agreed in writing by ROHM in advance, ROHM shall not be in any way responsible or liable for any damages, expenses or losses incurred by you or third parties arising from the use of any ROHM's Products for Specific Applications.

(Note1) Medical Equipment Classification of the Specific Applications

JAPAN	USA	EU	CHINA
CLASS III	CLASS III	CLASS II b	CLASS III
CLASS IV		CLASS III	

- ROHM designs and manufactures its Products subject to strict quality control system. However, semiconductor products can fail or malfunction at a certain rate. Please be sure to implement, at your own responsibilities, adequate safety measures including but not limited to fail-safe design against the physical injury, damage to any property, which a failure or malfunction of our Products may cause. The following are examples of safety measures:
 - Installation of protection circuits or other protective devices to improve system safety
 - Installation of redundant circuits to reduce the impact of single or multiple circuit failure
- Our Products are designed and manufactured for use under standard conditions and not under any special or extraordinary environments or conditions, as exemplified below. Accordingly, ROHM shall not be in any way responsible or liable for any damages, expenses or losses arising from the use of any ROHM's Products under any special or extraordinary environments or conditions. If you intend to use our Products under any special or extraordinary environments or conditions (as exemplified below), your independent verification and confirmation of product performance, reliability, etc. prior to use, must be necessary:
 - Use of our Products in any types of liquid, including water, oils, chemicals, and organic solvents
 - Use of our Products outdoors or in places where the Products are exposed to direct sunlight or dust
 - Use of our Products in places where the Products are exposed to sea wind or corrosive gases, including Cl₂, H₂S, NH₃, SO₂, and NO₂
 - Use of our Products in places where the Products are exposed to static electricity or electromagnetic waves
 - Use of our Products in proximity to heat-producing components, plastic cords, or other flammable items
 - Sealing or coating our Products with resin or other coating materials
 - Use of our Products without cleaning residue of flux (even if you use no-clean type fluxes, cleaning residue of flux is recommended); or Washing our Products by using water or water-soluble cleaning agents for cleaning residue after soldering
 - Use of the Products in places subject to dew condensation
- The Products are not subject to radiation-proof design.
- Please verify and confirm characteristics of the final or mounted products in using the Products.
- In particular, if a transient load (a large amount of load applied in a short period of time, such as pulse. is applied, confirmation of performance characteristics after on-board mounting is strongly recommended. Avoid applying power exceeding normal rated power; exceeding the power rating under steady-state loading condition may negatively affect product performance and reliability.
- De-rate Power Dissipation depending on ambient temperature. When used in sealed area, confirm that it is the use in the range that does not exceed the maximum junction temperature.
- Confirm that operation temperature is within the specified range described in the product specification.
- ROHM shall not be in any way responsible or liable for failure induced under deviant condition from what is defined in this document.

Precaution for Mounting / Circuit board design

- When a highly active halogenous (chlorine, bromine, etc.) flux is used, the residue of flux may negatively affect product performance and reliability.
- In principle, the reflow soldering method must be used on a surface-mount products, the flow soldering method must be used on a through hole mount products. If the flow soldering method is preferred on a surface-mount products, please consult with the ROHM representative in advance.

For details, please refer to ROHM Mounting specification

Precautions Regarding Application Examples and External Circuits

1. If change is made to the constant of an external circuit, please allow a sufficient margin considering variations of the characteristics of the Products and external components, including transient characteristics, as well as static characteristics.
2. You agree that application notes, reference designs, and associated data and information contained in this document are presented only as guidance for Products use. Therefore, in case you use such information, you are solely responsible for it and you must exercise your own independent verification and judgment in the use of such information contained in this document. ROHM shall not be in any way responsible or liable for any damages, expenses or losses incurred by you or third parties arising from the use of such information.

Precaution for Electrostatic

This Product is electrostatic sensitive product, which may be damaged due to electrostatic discharge. Please take proper caution in your manufacturing process and storage so that voltage exceeding the Products maximum rating will not be applied to Products. Please take special care under dry condition (e.g. Grounding of human body / equipment / solder iron, isolation from charged objects, setting of Ionizer, friction prevention and temperature / humidity control).

Precaution for Storage / Transportation

1. Product performance and soldered connections may deteriorate if the Products are stored in the places where:
 - [a] the Products are exposed to sea winds or corrosive gases, including Cl₂, H₂S, NH₃, SO₂, and NO₂
 - [b] the temperature or humidity exceeds those recommended by ROHM
 - [c] the Products are exposed to direct sunshine or condensation
 - [d] the Products are exposed to high Electrostatic
2. Even under ROHM recommended storage condition, solderability of products out of recommended storage time period may be degraded. It is strongly recommended to confirm solderability before using Products of which storage time is exceeding the recommended storage time period.
3. Store / transport cartons in the correct direction, which is indicated on a carton with a symbol. Otherwise bent leads may occur due to excessive stress applied when dropping of a carton.
4. Use Products within the specified time after opening a humidity barrier bag. Baking is required before using Products of which storage time is exceeding the recommended storage time period.

Precaution for Product Label

A two-dimensional barcode printed on ROHM Products label is for ROHM's internal use only.

Precaution for Disposition

When disposing Products please dispose them properly using an authorized industry waste company.

Precaution for Foreign Exchange and Foreign Trade act

Since concerned goods might be fallen under listed items of export control prescribed by Foreign exchange and Foreign trade act, please consult with ROHM in case of export.

Precaution Regarding Intellectual Property Rights

1. All information and data including but not limited to application example contained in this document is for reference only. ROHM does not warrant that foregoing information or data will not infringe any intellectual property rights or any other rights of any third party regarding such information or data.
2. ROHM shall not have any obligations where the claims, actions or demands arising from the combination of the Products with other articles such as components, circuits, systems or external equipment (including software).
3. No license, expressly or implied, is granted hereby under any intellectual property rights or other rights of ROHM or any third parties with respect to the Products or the information contained in this document. Provided, however, that ROHM will not assert its intellectual property rights or other rights against you or your customers to the extent necessary to manufacture or sell products containing the Products, subject to the terms and conditions herein.

Other Precaution

1. This document may not be reprinted or reproduced, in whole or in part, without prior written consent of ROHM.
2. The Products may not be disassembled, converted, modified, reproduced or otherwise changed without prior written consent of ROHM.
3. In no event shall you use in any way whatsoever the Products and the related technical information contained in the Products or this document for any military purposes, including but not limited to, the development of mass-destruction weapons.
4. The proper names of companies or products described in this document are trademarks or registered trademarks of ROHM, its affiliated companies or third parties.

General Precaution

1. Before you use our Products, you are requested to carefully read this document and fully understand its contents. ROHM shall not be in any way responsible or liable for failure, malfunction or accident arising from the use of any ROHM's Products against warning, caution or note contained in this document.
2. All information contained in this document is current as of the issuing date and subject to change without any prior notice. Before purchasing or using ROHM's Products, please confirm the latest information with a ROHM sales representative.
3. The information contained in this document is provided on an "as is" basis and ROHM does not warrant that all information contained in this document is accurate and/or error-free. ROHM shall not be in any way responsible or liable for any damages, expenses or losses incurred by you or third parties resulting from inaccuracy or errors of or concerning such information.