

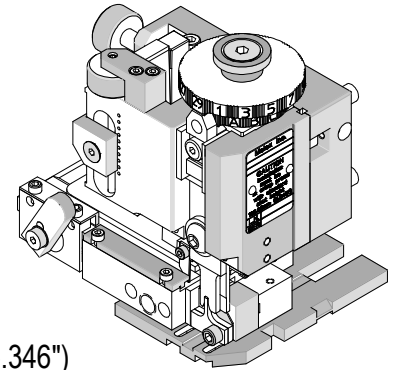

Mini-Mac Applicator Specification Sheet Order No. 63888-2200



FEATURES

- Directly adapts to most automatic wire processing machines
- Applicator designed to industry standard mounting and shut height 135.80mm (5.346")
- Quick set-up time; plus the crimp height, track and feed adjustments can be set without removing the applicator from the press
- Fine adjustment allows users to achieve target with little effort by adjusting in increments of .015mm (.0006") for conductor crimp height and .063mm (.0025") for insulation height
- Independent adjustment rings allow users to quickly adjust the conductor or insulation crimp height without affecting each other

SCOPE

Products: Mini KK® .100 Center Crimp Terminals 26-28 AWG.

Terminal Series No.	Terminal Order No.		Wire Size		Insulation Diameter				Strip Length	
					IPC/WHMA-A620 ♦		Terminal ♦♦			
					AWG	mm ²	mm	In.		
6459	50-30-4473	50-30-4483	26-28	0.13-0.08	1.19-1.30	.047-.051	1.19-1.30	.047-.051	2.54-3.18	.100-.125
	50-30-4474	50-30-4484								
	50-30-4475	50-30-4485								
	50-30-4479									

♦ To achieve optimum IPC-A620 insulation crimps, use this insulation OD range.
♦♦ Overall insulation OD specification for terminal. Note: Terminal will accommodate the UL1007 wires.

DEFINITION OF TERMS

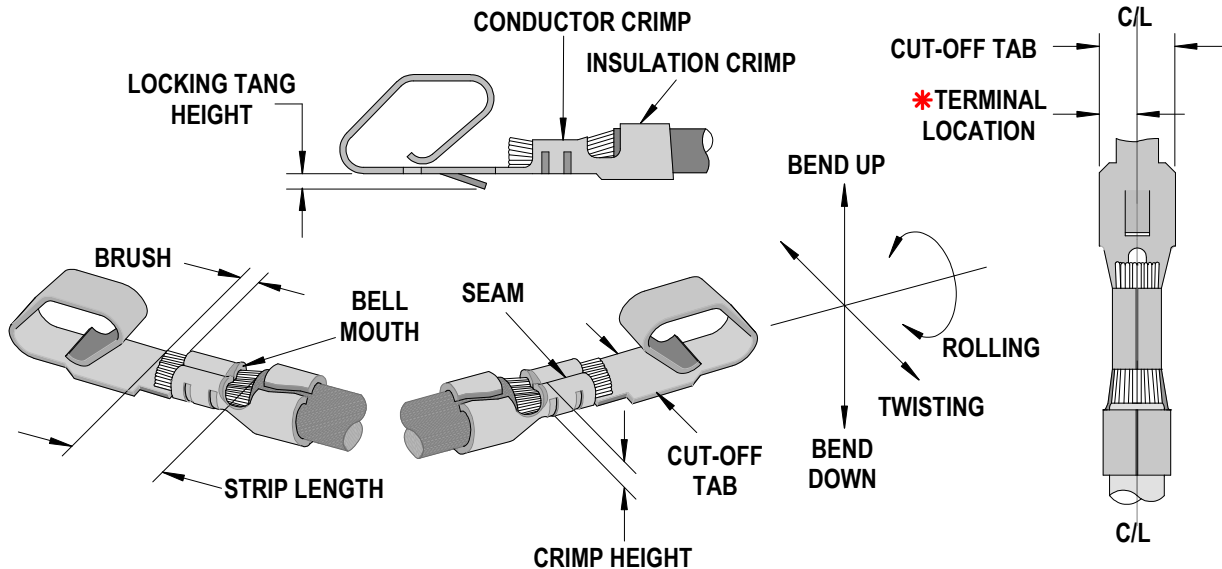

* Terminal is to be centrally located between the two (2) cut-off edges by 1/2 of the total cut-off tab tolerance.

CRIMP SPECIFICATIONS

Terminal Series No.	Bell mouth		*Cut-off Tab		Conductor Brush	
	mm	In.	mm	In.	mm	In.
6459	0.20-0.50	.008-.020	1.85-1.98	.073-.078	.00-1.00	.000-.040

Terminal Series No.	Locking Tang Height		Bend up	Bend down	Twist	Roll	Punch Width (Ref)				Seam Seam shall not be open and no wire allowed out of the crimping area.
	mm	In	Degree	Degree	mm	In	Conductor		Insulation		
							mm	In	mm	In	
6459	0.51-0.64	.020-.025	3	3	4	8	1.10	.043	1.60	.063	

After crimping, the conductor profile should measure the following.

Terminal Series No.	Wire Size		Crimp Height		Crimp Width (Ref)		Pull Force Minimum	
	AWG	mm ²	mm	In.	mm	In.	N	Lb.
6459	26	0.13	0.61-0.66	.024-.026	1.15	.045	17.8	4.0
	28	0.08	0.57-0.62	.022-.024	1.15	.045	13.3	3.0

Pull Force should be measured with no influence from the insulation crimp.
The above specifications are guidelines to an optimum crimp.

PARTS LIST

Mini-Mac Applicator 63888-2200				
Item	Order No	Engineering No.	Description	Quantity
Perishable Tooling				
	63888-2270	63888-2270	Tool Kit (All "Y" Items)	REF
1	638910031	638910031	Conductor Punch	1 Y
2	638910081	638910081	Conductor Anvil	1 Y
3	63891-0030	63891-0030	Insulation Punch	1 Y
4	63891-0080	63891-0080	Insulation Anvil	1 Y
5	11-18-4009	60703-11	Cut-Off Punch	1 Y
6	11-18-4468	60703-19	Cut-off Insert	1 Y
Other Components				
7	11-18-4001	60703-3	Cover Plate	1
8	11-18-4003	60703-5	Front Cover	1
9	11-18-4004	60703-6	Insulation Punch Spacer	1
10	11-18-4006	60703-8	Stripper Blade Holder	1
11	11-18-4332	60703-16	Stripper	1
12	11-18-4469	60703-20	Retainer Block	1
13	11-40-4085	8301-10	Terminal Stop and Scrape Shield	1
14	63803-5117	63803-5117	Conductor Bushing	1
15	63820-0001	63820-0001	Cover-Drag Frame	1
Frame				
16	63801-3201	63801-3201	Top	1
17	63801-3283	63801-3283	Base	1
18	63801-6550	63801-6550	Track	1
Hardware				
19	N/A	N/A	M3 by 6 Long SHCS	2**
20	N/A	N/A	M3 by 8 Long SHCS	2**
21	N/A	N/A	M4 by 6 Long SHCS	2**
22	N/A	N/A	M4 by 12 Long BHCS	2**
23	N/A	N/A	M5 by 10 Long SHCS	1**
24	N/A	N/A	M8 by 20 Long BHCS	1**
25	N/A	N/A	#4-40 by .19" Long SHCS	2**
26	N/A	N/A	#6-32 by 3/8" Long BHCS	2**
27	N/A	N/A	#10-32 by 1.120" Long SHCS	1**
** Available from an industrial supply company such as MSC (1-800-645-7270).				

Assembly Drawing

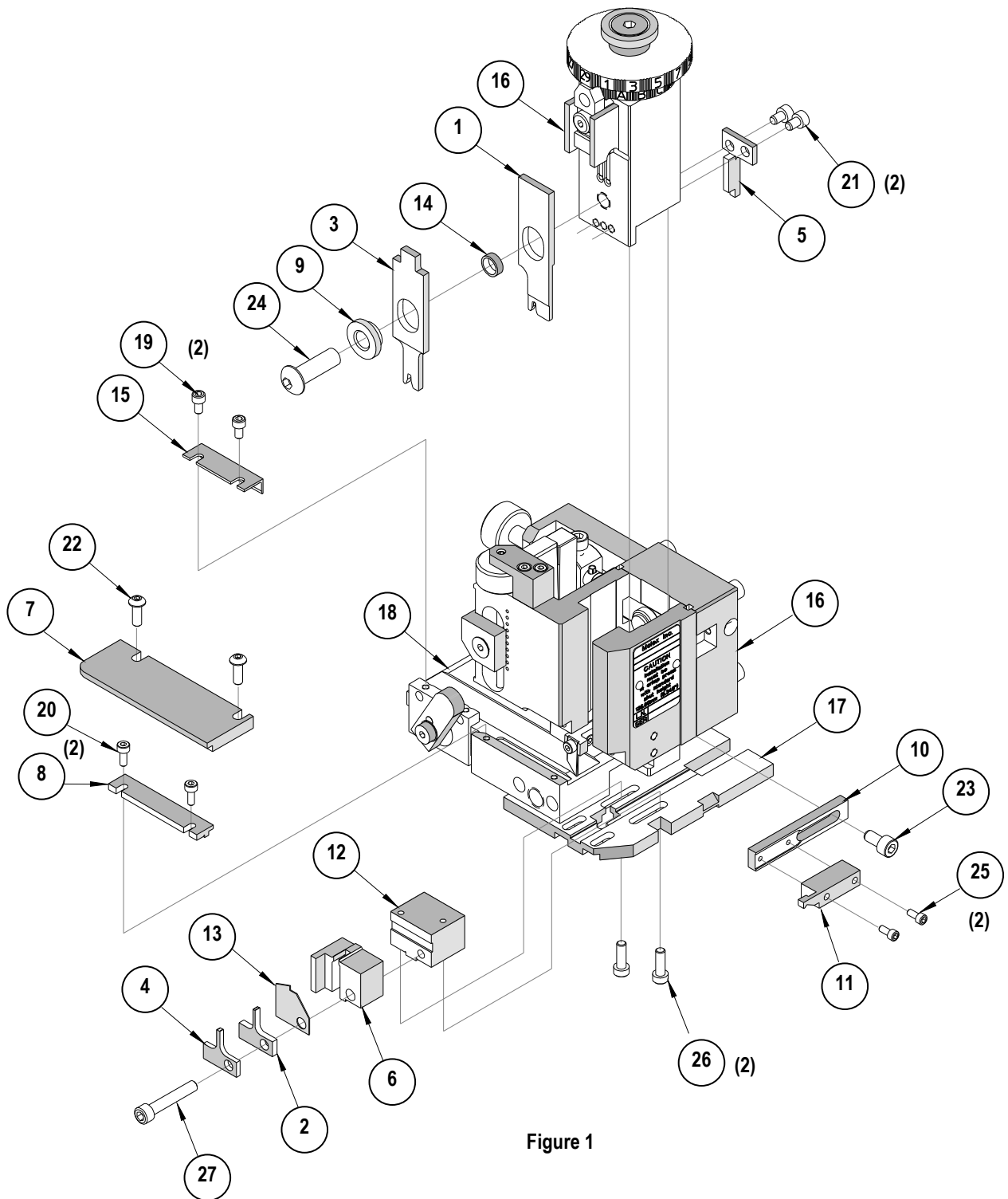

Figure 1

NOTES

1. Molex recommends an extra perishable tooling kit be maintained at your facility.
2. Verify tooling alignment by manually cycling the press and Applicator before crimping under power. Check that all screws are tight.
3. Slugs, Terminals, Dirt and Oil should be kept clear of work area.
4. Wear safety glasses at all times.
5. For recommended maintenance refer to the Mini-Mac Manual.

CAUTION: This applicator should only be used in a press with a shut height of 135.8 mm (5.346"). Tooling damage could result at a lower setting.

CAUTION: To prevent injury never operate this Applicator without the guards supplied with the press or wire-processing machine in place. Reference the press or wire processing manufacturer's instruction manual.

CAUTION: Molex crimp specifications are valid only when used with Molex terminals, applicators and tooling.

Americas Headquarters
Lisle, Illinois 60532 U.S.A.
1-800-78MOLEX
amerinfo@molex.com

Far East North Headquarters
Yamato, Kanagawa, Japan
81-462-65-2324
feninfo@molex.com

Far East South Headquarters
Jurong, Singapore
65-6-268-6868
fesinfo@molex.com

European Headquarters
Munich, Germany
49-89-413092-0
eurinfo@molex.com

Corporate Headquarters
2222 Wellington Ct.
Lisle, IL 60532 U.S.A.
630-969-4550
Fax: 630-969-1352

Visit our Web site at <http://www.molex.com>