

# KAI-1003

## 1024 (H) x 1024 (V) Interline CCD Image Sensor

### Description

The KAI-1003 Image Sensor is a high-performance megapixel monochrome image sensor designed for a wide range of medical imaging and machine vision applications.

The 12.8  $\mu\text{m}$  square pixels with microlenses provide high sensitivity and the large capacity results in large dynamic range. The two output, split horizontal register and several binning modes allow a 15 to 60 frame per second (fps) video rate for the progressively scanned images.

The vertical overflow drain structure provides anti-blooming protection, and enables electronic shuttering for precise exposure control. Other features include low dark current, negligible lag and low smear.

**Table 1. GENERAL SPECIFICATIONS**

Parameter	Typical Value
Architecture	Interline CDD; Progressive Scan
Total Number of Pixels	1056 (H) $\times$ 1032 (V)
Number of Effective Pixels	1028 (H) $\times$ 1028 (V)
Number of Active Pixels	1024 (H) $\times$ 1024 (V)
Pixel Size	12.8 $\mu\text{m}$ (H) $\times$ 12.8 $\mu\text{m}$ (V)
Active Image Size	13.1 mm (H) $\times$ 13.1 mm (V), 18.5 mm (Diagonal), 4/3" Optical Format
Aspect Ratio	1:1
Number of Outputs	1 or 2
Charge Capacity	170,000 e <sup>-</sup>
Output Sensitivity	7.5 $\mu\text{V}/\text{e}^-$
Quantum Efficiency (500 nm)	45%
Read Noise (f = 20 MHz)	40 e <sup>-</sup> rms
Dark Current	< 0.5 nA/cm <sup>2</sup>
Dynamic Range	72 dB
Blooming Suppression	> 100 X
Smear	-80 dB
Maximum Pixel Clock Speed	20 MHz
Maximum Frame Rate Single Output Dual Output Dual Output 2 $\times$ 2 Bin	15 fps 30 fps 60 fps
Package	28-Pin CERDIP
Cover Glass	AR Coated, 2 Sides

NOTE: All Parameters are specified at T = 40°C unless otherwise noted.



**ON Semiconductor®**

[www.onsemi.com](http://www.onsemi.com)

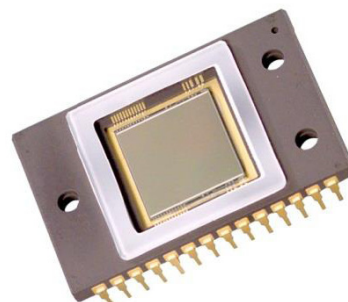

**Figure 1. KAI-1003 Interline CCD Image Sensor**

### Features

- Megapixel Progressive Scan Interline CCD
- 1024 (H)  $\times$  1024 (V) Imaging Pixels
- 12.8  $\mu\text{m}$  Square Pixels
- 13.1 mm Square Imaging Area
- Microlenses for Increased Sensitivity
- Large Capacity (170 ke<sup>-</sup>)
- Split Horizontal Register for 1 or 2 Outputs
- Binning to 1  $\times$  2 or 2  $\times$  2

### Applications

- Machine Vision
- Medical
- Scientific

### ORDERING INFORMATION

See detailed ordering and shipping information on page 2 of this data sheet.

# KAI-1003

## ORDERING INFORMATION

**Table 2. ORDERING INFORMATION – KAI-1003 IMAGE SENSOR**

Part Number	Description	Marking Code
KAI-1003-AAA-CR-AE	Monochrome, No Microlens, CERDIP Package (Sidebrazed), Taped Clear Cover Glass with AR Coating (Both Sides), Engineering Sample	KAI-1003 Serial Number
KAI-1003-AAA-CR-B2	Monochrome, No Microlens, CERDIP Package (Sidebrazed), Taped Clear Cover Glass with AR Coating (Both Sides), Grade 2	
KAI-1003-ABA-CD-AE	Monochrome, Telecentric Microlens, CERDIP Package (Sidebrazed), Clear Cover Glass with AR Coating (Both Sides), Engineering Sample	KAI-1003M Serial Number
KAI-1003-ABA-CD-B2	Monochrome, Telecentric Microlens, CERDIP Package (Sidebrazed), Clear Cover Glass with AR Coating (Both Sides), Grade 2	

**Table 3. ORDERING INFORMATION – EVALUATION SUPPORT**

Part Number	Description
KAI-1003-12-20-A-EVK	Evaluation Board (Complete Kit)

See the ON Semiconductor *Device Nomenclature* document (TND310/D) for a full description of the naming convention used for image sensors. For reference documentation, including information on evaluation kits, please visit our web site at [www.onsemi.com](http://www.onsemi.com).

DEVICE DESCRIPTION

Architecture

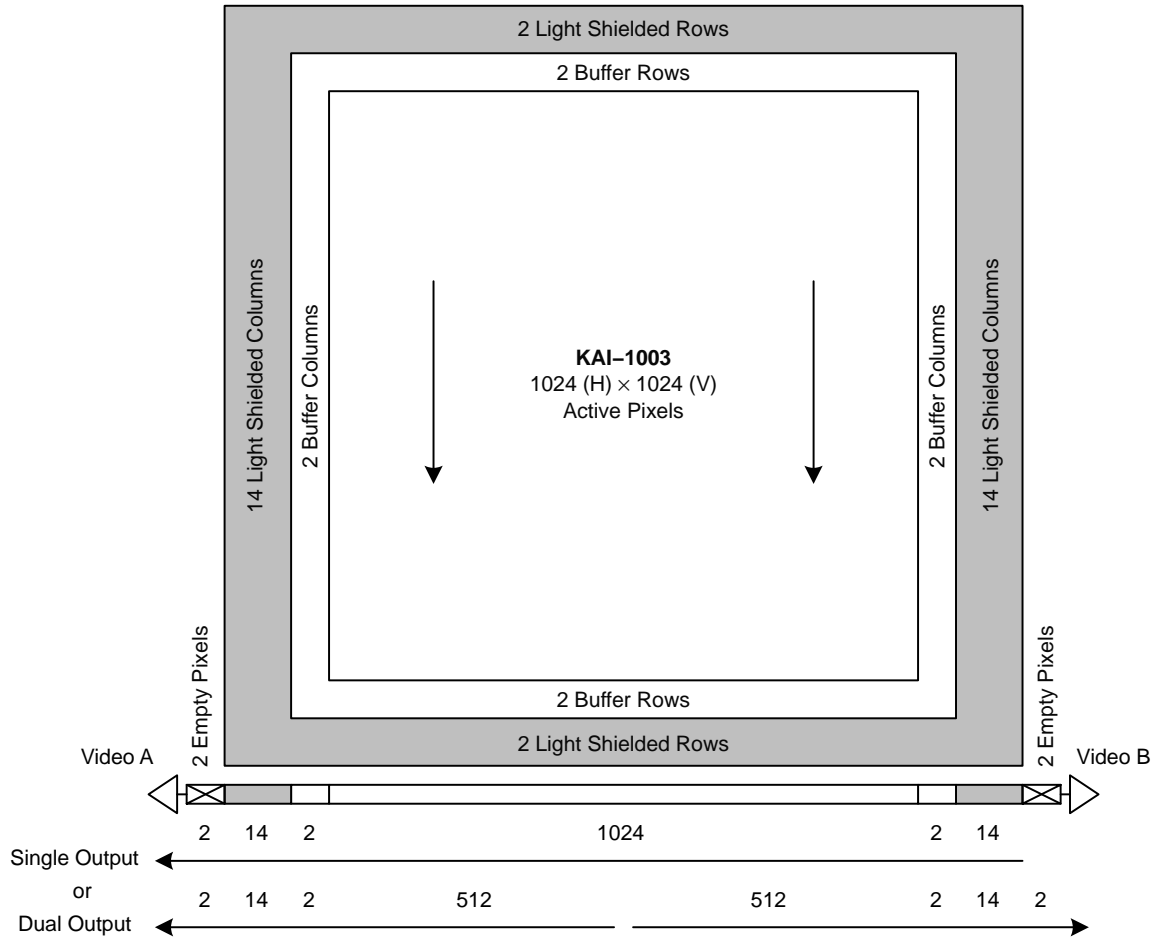

Figure 2. Sensor Architecture

The KAI-1003 is a high-performance, interline charge-coupled device (CCD) designed for a wide range of medical imaging and machine vision applications. The device is built using an advanced two-phase, double-polysilicon, NMOS CCD technology. The p+n-pn-photodiodes eliminate image lag while providing anti-blooming protection and electronic shutter capability. The 12.8 μm square pixels with microlenses provide high sensitivity and large dynamic range. The two output, split horizontal register and several binning modes enable a 15 to 60 frame per second (fps) video rate with this megapixel progressive scan imager.

**Image Acquisition**

An electronic representation of an image is formed when incident photons falling on the sensor plane create electron-hole pairs within the individual silicon photodiodes. These photoelectrons are collected locally by the formation of potential wells at each photodiode. Below photodiode saturation, the number of photoelectrons collected at each pixel is linearly dependent on light level

and integration time and non-linearly dependent on wavelength. When the photodiode's charge capacity is reached, excess electrons are discharged into the substrate to prevent blooming. The integration time can be decreased below the frame time by using an electronic shutter, which is a voltage pulse applied to the substrate to empty the photodiodes.

**Charge Transport**

The integrated charge from each photodiode is transported to the output by a three-step process. The charge is first transferred from the photodiodes to the vertical shift registers by applying a large positive voltage to one of the vertical CCD phases. This transfer occurs simultaneously for all photodiodes. The charge is then transported from the vertical CCD registers to the horizontal CCD line by line in parallel. Finally, the horizontal CCD register transports each line of charge pixel by pixel serially to one or both of the output structures.

The single horizontal CCD register is split into two halves to allow a variety of line readout modes, as shown in

## KAI-1003

Figure 2 and Figure 3. The A output half of the register is a true two-phase design, which results in unidirectional transport using phases H1A and H2A. The B output half of the register is a pseudo two-phase design, which allows bi-directional transport using phases H1B, H2B, H1C and H2C. Dual output is achieved with all of the first phases identical and all the second phases identical. If the clocks of H1A and H2A phases are shifted by one half cycle, the output remains dual with the outputs alternating, so that only one analog-to-digital converter is necessary. Finally, single output of the entire image from the A output is obtained by

complementing the C phases, which reverses transport in the B half of the horizontal CCD.

Binning can be used in a 1×2 and a 2×2 mode. Two successive vertical transfers vertically bin the charge directly onto the horizontal CCD, as shown in Figure 13 and Figure 14. Horizontal binning is accomplished by two successive horizontal transfers onto the H22 gate, which then transfers the charge to the output structure, as shown in Figure 15.

Combinations of output modes, binning and horizontal clock frequency allow the range of frame rates listed in.

**Table 4. KAI-1003 CALCULATED CLOCK PARAMETERS**

Parameter	Binning (H × V)	1×1	1×2	2×1	2×2	1×1	Unit
	Output	Dual	Dual	Dual	Dual	Single	
<b>HORIZONTAL CLOCK</b>							
Frequency		20	20	20	40	20	MHz
Period	Actual	50	50	50	25	50	ns
	Effective	50	50	100	50	50	
Pixel Counts	Actual	532	532	532	532	1060	
	Effective	532	532	266	266	1060	
<b>VERTICAL TO HORIZONTAL TRANSFER (HORIZONTAL RETRACE TIME)</b>							
Equivalent H-Clock Counts (m)		80	80	80	160	80	
Duration		4.0	4.0	4.0	4.0	4.0	μs
<b>HORIZONTAL LINE TIME</b>							
Total H-Clock Counts		612	612	612	692	1140	
Line time		30.6	30.6	30.6	17.3	57.0	μs
<b>VERTICAL CLOCK</b>							
Line Counts	Actual Effective	1032 1032	1032 516	1032 516	1032 516	1032 1032	
<b>PHOTODIODE READ (VERTICAL RETRACE TIME)</b>							
Equivalent Line Counts (n)		4	4	4	7	2	
Duration		122.4	122.4	122.4	121.1	114.0	μs
<b>FRAME RATE</b>							
Total Effective Line Counts		1036	520	520	523	1034	
Frame Time		31.7	15.9	15.9	9.0	58.9	ms
Frame Rate		31.5	62.8	62.8	110.5	17.0	frames/s

1. Time values have been rounded.
2. The number of counts (n and m) shown here are nominal integers, but in general they do not need be integers. They can be adjusted for frame time, so long as the horizontal and vertical retrace times exceed the minimums specified in AC Timing Requirements.
3. Operation at 40 MHz will have increased readout noise.

**Output Structure**

Charge presented to the floating diffusion (FD) is converted into a voltage and current amplified in order to drive off-chip loads. The resulting voltage change seen at the output is linearly related to the amount of charge placed on the FD. Once the signal has been sampled by the system electronics, the reset gate ( $\phi_R$ ) is clocked to remove the signal and the FD is reset to the potential applied by the reset drain (RD). More signal at the floating diffusion reduces the voltage seen at the output pin. In order to activate the output structure, an off-chip load must be added to the output pin of the device.

**Non-Imaging Pixels**

In addition to the 1024 (H) by 1024 (V) imaging pixels, there are active buffer, light shielded and empty pixels, as

shown in Figure 2. A two-pixel border of active buffer pixels surrounds the imaging area. These buffer pixels respond to illumination but are not tested for defects and non-uniformities. Two light shielded rows lead and follow each frame, and 14 light shielded columns lead and follow each line. The light shielded columns are tested for column defects and can be used for dark reference. Only the center 10 columns by 1028 rows of light shielded region on each side can be used for dark reference due to light leakage into the border of two pixels at the edges. Finally, two empty pixels occur at the beginning of each line, which are empty shift register cycles not associated with any vertical CCD columns. Empty pixels may also occur at the end of the line, depending on the timing.

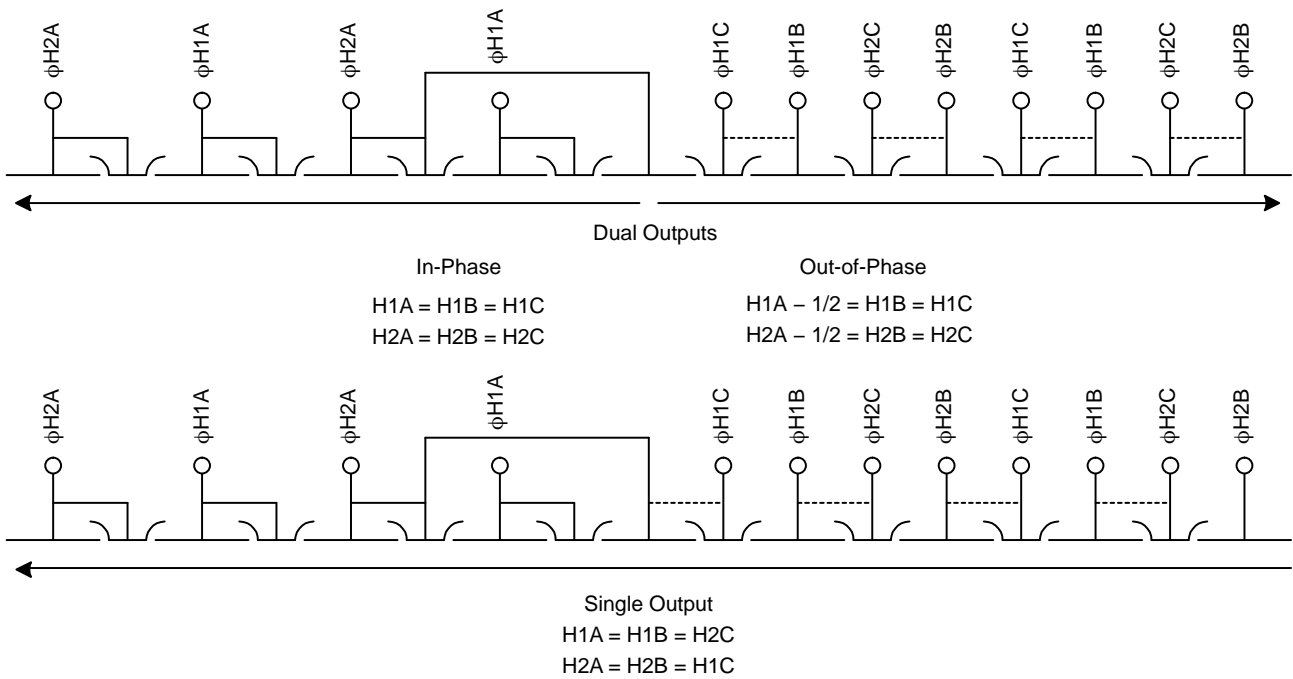

Figure 3. Horizontal CCD Registers

# KAI-1003

## Pin Description and Device Orientation

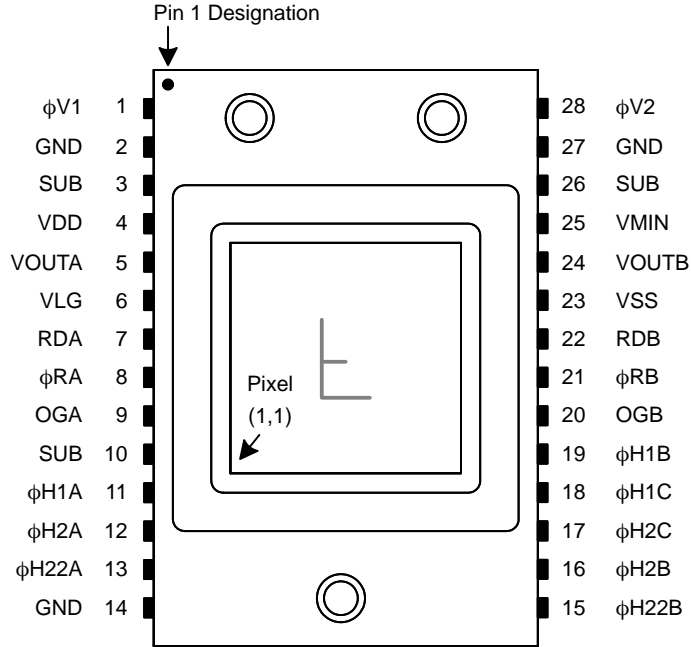

Figure 4. Pin Description (Top View)

Table 5. PIN DESCRIPTION

Pin No.	Label
1	$\phi V1$
2	GND
3	SUB
4	VDD
5	VOUTA
6	VLG
7	RDA
8	$\phi RA$
9	OGA
10	SUB
11	$\phi H1A$
12	$\phi H2A$
13	$\phi H22A$
14	GND

Pin No.	Label
15	$\phi H22B$
16	$\phi H2B$
17	$\phi H2C$
18	$\phi H1C$
19	$\phi H1B$
20	OGB
21	$\phi RB$
22	RDB
23	VSS
24	VOUTB
25	VMIN
26	SUB
27	GND
28	$\phi V2$

PERFORMANCE SPECIFICATIONS

**Table 6. PERFORMANCE SPECIFICATIONS**

(All values measured at 40°C and 30 fps (integration time = 33 ms,  $f_H = 20$  MHz) for nominal operating parameters unless otherwise noted. These parameters exclude defective pixels.)

Description	Symbol	Min.	Nom.	Max.	Unit
Saturation Charge Capacity with Blooming Control	$Q_{SAT}$	170	-	-	$ke^-$
Output Gain		6.5	7.5	8.5	$\mu V/e^-$
Output Voltage at the Saturation Level	$V_{SAT}$	-	1.3	-	V
Quantum Efficiency at 500 nm		-	32	-	%
Quantum Efficiency at 540 nm		-	30	-	%
Quantum Efficiency at 600 nm		-	24	-	%
CCD Readout Noise with CDS		-	40	50	$e^-$ rms
Dark Current	$I_{DARK}$	-	0.25	0.45	$nA/cm^2$
Anti-Blooming Factor (Notes 1, 2)	$X_{AB}$	100	-	-	
Vertical Smear (Notes 2, 6)		-	0.005	0.01	%
Non-Uniformity of Sensitivity (Notes 3, 4)		-	0.3	0.5	% rms
Non-Uniformity of Dark Current (Note 4)		-	14	-	$e^-$ rms
Output Signal Non-Linearity (Note 5)		-	1	2	%
Gain Difference between the Two Video Outputs (Note 5)		-	-	10	%
Non-Uniformity of Gain between the Two Outputs (Note 5)		-	0.5	1.5	%

1. The illumination required to bloom the image sensor reported as a multiple of the saturation intensity. Blooming is defined as doubling the vertical height of a spot that is 10% of the vertical CCD height at the saturation intensity.
2. Measured with continuous green light centered at 550 nm, F/4 optics and a spot size that is 10% of the vertical CCD height.
3. Measured at 90% of 150  $ke^-$  output.
4. Measured in the center  $50 \times 50$  pixels.
5. Between 10% and 90% of 150  $ke^-$  output.
6. Measured without electronic shutter operation.

Typical Quantum Efficiency

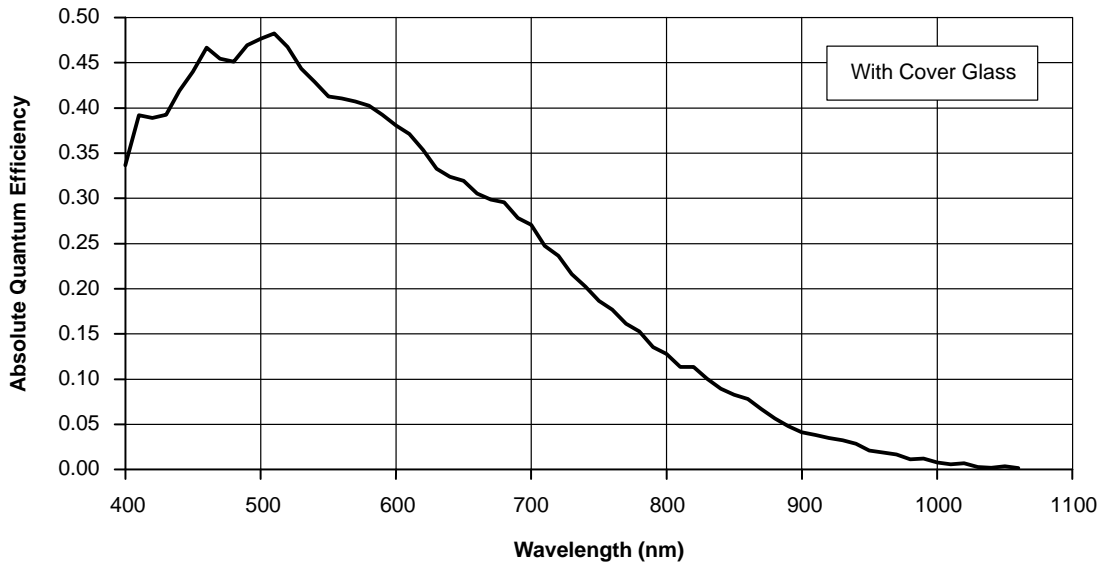
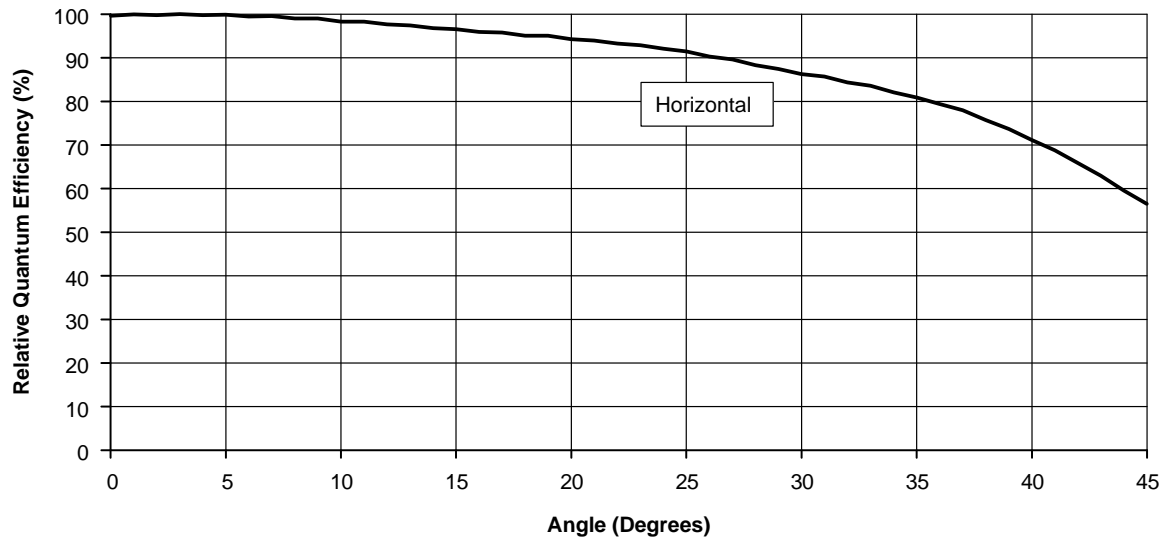

Figure 5. Quantum Efficiency Spectrum

**Angular Dependence of Quantum Efficiency**

For the curve marked "Horizontal", the incident light angle is varied in a plane parallel to the HCCD.



**Figure 6. Angular Dependence of Quantum Efficiency**



**DEFECT SPECIFICATIONS**

**Defect Test Conditions**

Temperature: 40°C  
Integration Time: 33 ms (20 MHz HCCD Frequency, No Binning, 30 fps Frame Rate)  
Light Source: Continuous Green Light Centered at 550 nm  
Operation: Nominal Voltages and Timing

**Table 7. DEFECT DEFINITIONS**

Name	Maximum Number	Definition
Major Defective Pixel	20	A pixel whose signal deviates by more than 25 mV from the mean value of all active pixels under dark field condition or by more than 8% from the mean value of all active pixels under uniform illumination at 105 ke <sup>-</sup> output signal.
Minor Defective Pixel	100	A pixel whose signal deviates by more than 8 mV from the mean value of all active pixels under dark field condition.
Cluster Defect	4	A group of 2 to 6 contiguous major defective pixels, but no more than 2 adjacent defects horizontally.
Column Defect	0	A group of more than 6 contiguous major defective pixels along a single column.

**Defect Proximity**

Minimum Distance between Defective Clusters: 2 Pixels in All Directions without Major Pixel Defects  
Minimum Distance between Defective Columns: 3 Columns without Column Defects or Cluster Defects

OPERATION

Table 8. ABSOLUTE MAXIMUM RATINGS

Item	Description	Min.	Max	Unit
Temperature	Operation to Specification	0	40	°C
	Operation without Damage	-10	70	°C
	Storage	-55	80	°C
Relative Humidity	Operation without Damage (Note 1)	0	95	%
Voltage (Between Pins)	SUB – GND (Notes 2, 5)	-0.6	50	V
	V <sub>RD</sub> , V <sub>SS</sub> , V <sub>DD</sub> – GND	-0.6	25	V
	V <sub>MIN</sub> – GND	-15	0.6	V
	All Clocks – GND	-	17	V
	φV1 – φV2 (Note 3)	-	17	V
	φH1 – φH2	-	17	V
	φH1, φH2 – φV2	-	17	V
	φH2 – OG	-	17	V
	V <sub>LG</sub> , OG – GND	-	17	V
	φR, φH1, φH2 – V <sub>MIN</sub>	-	17	V
Capacitance	Output Load Capacitance (C <sub>LOAD</sub> ) (Note 4)	-	10	pF
Current	Output Bias Current (I <sub>DD</sub> ) (Note 4)	-	10	mA

Stresses exceeding those listed in the Maximum Ratings table may damage the device. If any of these limits are exceeded, device functionality should not be assumed, damage may occur and reliability may be affected.

- Without condensation.
- Under normal operating conditions, the substrate voltage should be maintained above 8.0 V. The substrate voltage should not remain above 25 V for longer than 100 μs.
- Maximum of 20 V for φV1H – φV2L, with 20 μs maximum duration.
- Each output.
- Refer to Application Note *Using Interline CCD Image Sensors in High Intensity Visible Lighting Conditions*.

Table 9. DC OPERATING CONDITIONS

Description	Symbol	Min.	Nom.	Max.	Unit
Output Gate	OG	1.8	2.0	2.2	V
Reset Drain	V <sub>RD</sub>	10.0	10.5	11.0	V
Output Amplifier Return (Note 1)	V <sub>SS</sub>	-	0.0	-	V
Output Amplifier Load Gate	V <sub>LG</sub>	1.4	1.5	1.6	V
Output Amplifier Supply	V <sub>DD</sub>	14.5	15.0	15.5	V
Disable ESD Protection (Note 2)	V <sub>MIN</sub>	-	-8.5	-	V
Substrate (Notes 3, 4, 5)	V <sub>SUB</sub>	8.0	TBS	18.0	V
Ground, P-Well (Note 4)	GND	-	0.0	-	V

- Current sink.
- Connect a 0.001 μF capacitor between V<sub>MIN</sub> and GND. V<sub>MIN</sub> must be more negative than the low voltage of any of the φH clocks and should be established before the φH voltage is applied.
- DC value when electronic shutter is not in use. See AC Clock Level Conditions for electronic shutter pulse voltage. The operating value of the substrate voltage, V<sub>SUB</sub>, will be supplied with each shipment.
- Ground and substrate biases should be established before other gate and diode potentials are applied.
- Refer to Application Note *Using Interline CCD Image Sensors in High Intensity Visible Lighting Conditions*.

**Table 10. AC CLOCK LEVEL CONDITIONS**

Description	Level	Symbol	Min.	Nom.	Max.	Unit
Vertical CCD Clocks (Note 1)	High	$\phi V2H$	9.5	10.5	11.5	V
	Mid	$\phi V1M, \phi V2M$	-0.8	-0.5	0.0	V
	Low	$\phi V1L, \phi V2L$	-9.0	-8.5	-8.0	V
Horizontal CCD Clocks (Note 1)	High	$\phi H1H, \phi H2H$	4.5	5.0	5.5	V
	Low	$\phi H1L, \phi H2L$	-6.5	-6.0	-5.5	V
Reset Clock	Amplitude	$\phi R_{SWING}$	-	5.0	-	V
	Low (Note 2)	$V_{\phi Rlow}$	0	TBS	5.0	V
Electronic Shutter Pulse (Notes 3, 4)	Shutter	$V_{SHUTTER}$	37	40	45	V

1. For best results, the CCD clock swings must be greater than or equal to the nominal values.
2. Reset clock low level voltage will be supplied with each shipment.
3. Electronic shutter pulse voltage referenced to GND. See DC Operating Conditions for DC level when electronic shutter is not in use.
4. Refer to Application Note *Using Interline CCD Image Sensors in High Intensity Visible Lighting Conditions*.

**Electronic Shutter Operation**

Electronic shuttering is accomplished by pulsing the substrate voltage to empty the photodiodes. See Figure 16

for timing. The pulse must not occur while useful information is being read from a line.

**Table 11. CALCULATED CLOCK CAPACITANCE**

Description	Phase	Symbol	Typical	Unit
Vertical CCD Clocks (Note 1)	1 to GND	$C_{\phi V1}$	55/37	nF
	2 to GND	$C_{\phi V2}$	50/32	nF
	1 to 2	$C_{\phi V1 - \phi V2}$	4	nF
Horizontal CCD Clocks (Notes 1, 2)	1A	$C_{\phi H1A}$	58/21	pF
	1B	$C_{\phi H1B}$	41/13	pF
	1C	$C_{\phi H1C}$	15/10	pF
	2A	$C_{\phi H2A}$	48/22	pF
	2B	$C_{\phi H2B}$	30/11	pF
	2C	$C_{\phi H2C}$	18/13	pF
HCCD Summing Clock		$C_{\phi H22A/B}$	3	pF
Reset Clock – GND		$C_{\phi RA/B}$	5	pF

1. Accumulation/depletion capacitances.
2. Capacitance of this gate to GND and all other gates.

Table 12. AC TIMING REQUIREMENTS

Description	Symbol	Min.	Nom.	Max.	Unit
Vertical High Level Duration	$t_{V2H}$	15	–	20	$\mu\text{s}$
Vertical Transfer Time (Note 1)	$t_V$	1.0	2.0/1.0	–	$\mu\text{s}$
Vertical Pedestal Delay 1 & 3	$t_{VPD1}, t_{VPD3}$	40	–	–	$\mu\text{s}$
Vertical Pedestal Delay 2	$t_{VPD2}$	15	–	–	$\mu\text{s}$
Horizontal Delay (Note 1)	$t_{HD}$	1.5/0.5	–	–	$\mu\text{s}$
Reset Duration (Note 2)	$t_R$	–	10	–	ns
Horizontal CCD Clock Frequency (Note 3)	$f_H$	–	20	–	MHz
Pixel Time	$t_H$	–	50	–	ns
Line Time (Note 4)	$t_L$	–	–	–	
Frame Time (Note 4)	$t_F$	–	–	–	
Clamp Delay (Note 5)	$t_{CD}$	–	–	–	ns
Sample Delay (Note 5)	$t_{SD}$	–	–	–	ns
Electronic Shutter Pulse Duration	$t_{ES}$	5	7.5	10	$\mu\text{s}$
Electronic Shutter Horizontal Delay	$t_{ESHD}$	1.0	–	–	$\mu\text{s}$

1. Non-binning/binning times.
2. The rising edge of  $\phi_R$  should be coincident with the rising edge of  $\phi_{H22}$ , within  $\pm 5$  ns.
3. Horizontal CCD clock frequency can be increased to 40 MHz, with increased readout noise.
4. See Table 4 for nominal line and frame time in each mode.
5. The clamp delay and sample delay should be adjusted for optimum results.

Table 13. CCD CLOCK WAVEFORM CONDITIONS

Description	Phase	Symbol	$t_{WH}$	$t_{WL}$	$t_R$	$t_F$	Unit
<b>NON-BINNING</b>							
Vertical CCD Clocks	1	$\phi_{V1M/L}$	–	1.5	0.5	0.5	$\mu\text{s}$
	2	$\phi_{V2M/L}$	1.5	–	0.5	0.5	$\mu\text{s}$
	2, High	$\phi_{V2H}$	15	–	1.0	1.0	$\mu\text{s}$
Horizontal CCD Clocks	1	$\phi_{H1}$	20.5	21.5	4.0	4.0	ns
	2	$\phi_{H2}$	20.5	21.5	4.0	4.0	ns
	2, Binning (Note 1)	$\phi_{H22}$	20.5	21.5	4.0	4.0	ns
Reset clock		$\phi_R$	5	39	3	3	ns
<b>2x2 BINNING</b>							
Vertical CCD Clocks	1 (Note 2)	$\phi_{V1M/L}$	0.5	0.5	0.5	0.5	$\mu\text{s}$
	2 (Note 2)	$\phi_{V2M/L}$	0.5	0.5	0.5	0.5	$\mu\text{s}$
	2, High	$\phi_{V2H}$	15	–	1.0	1.0	$\mu\text{s}$
Horizontal CCD Clocks	1	$\phi_{H1}$	20.5	21.5	4.0	4.0	ns
	2	$\phi_{H2}$	20.5	21.5	4.0	4.0	ns
	2, Binning	$\phi_{H22}$	46.0	46.0	4.0	4.0	ns
Reset clock		$\phi_R$	5	89	3	3	ns

1. Typical values measured with clocks connected to image sensor device. The actual values should be optimized for particular board layout.
2.  $\phi_{H22}$  may be connected to  $\phi_{H2}$  in  $1 \times 1$  mode.
3.  $t_{WH}$  and  $t_{WL}$  for  $\phi_{V1M/L}$  and  $\phi_{V2M/L}$  are the time periods during the double pulses.

# KAI-1003

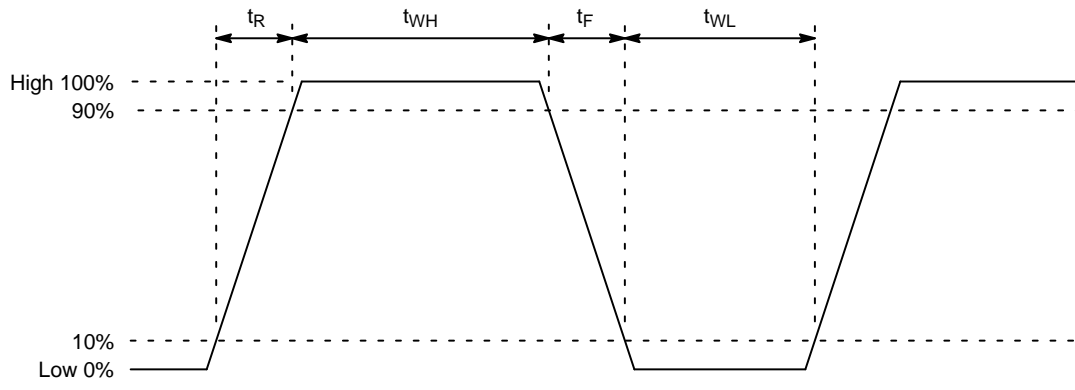

Figure 7. CCD Clock Waveform

TIMING

Frame Timing - 1x1

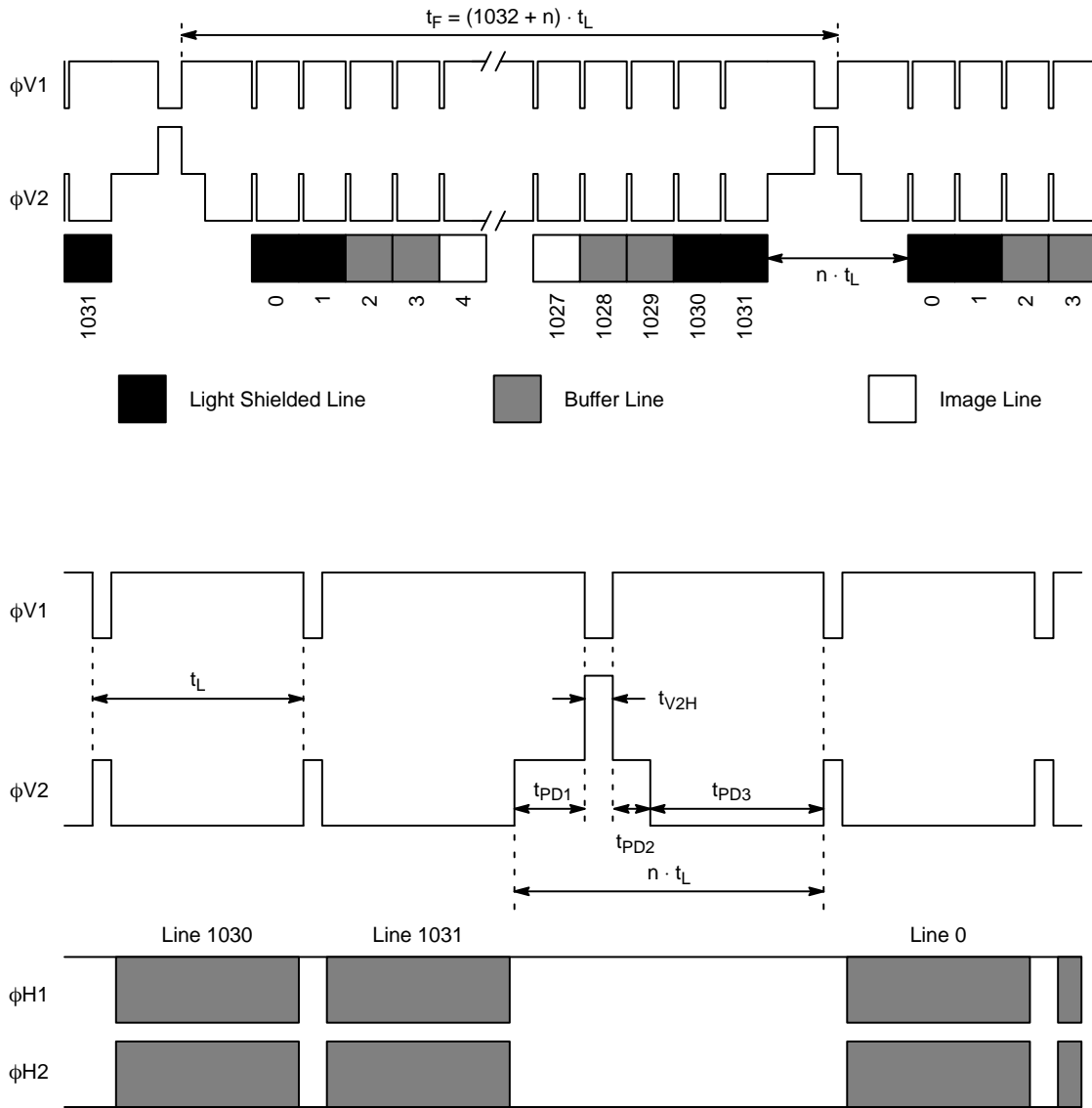

Figure 8. Frame Timing - 1x1

Line Timing – 1x1 – Single Output

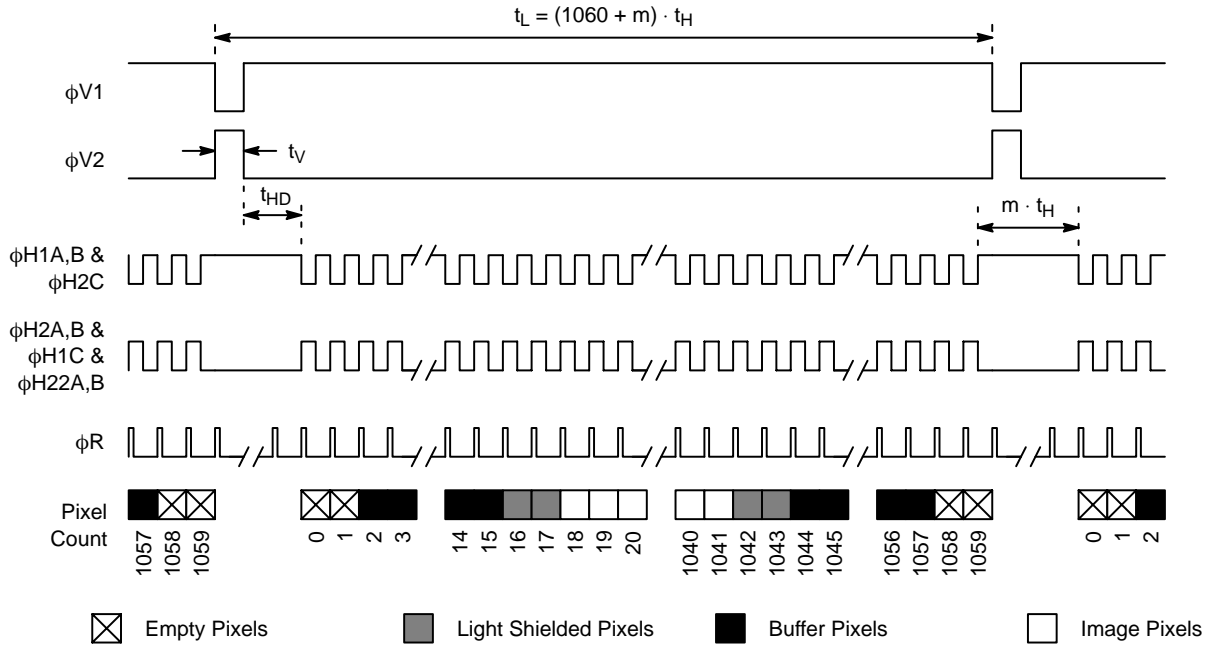

Figure 9. Line Timing – 1x1 – Single Output

Line Timing – 1x1 – Dual Output, In-Phase

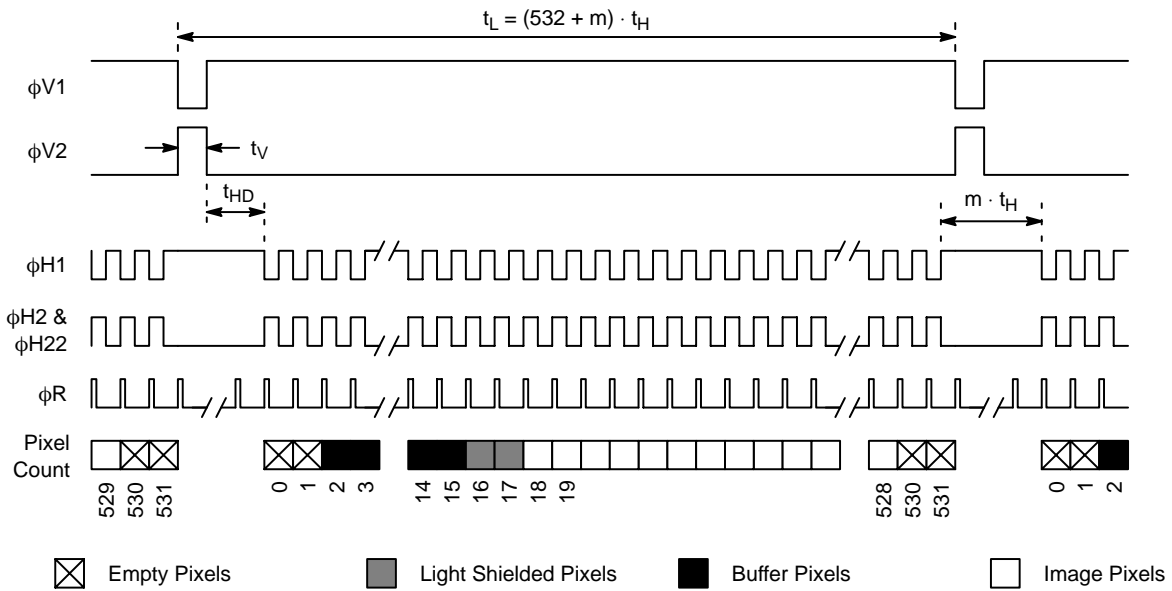

Figure 10. Line Timing – 1x1 – Dual Output, In-Phase

Line Timing – 1x1 – Dual Output, Out-of-Phase

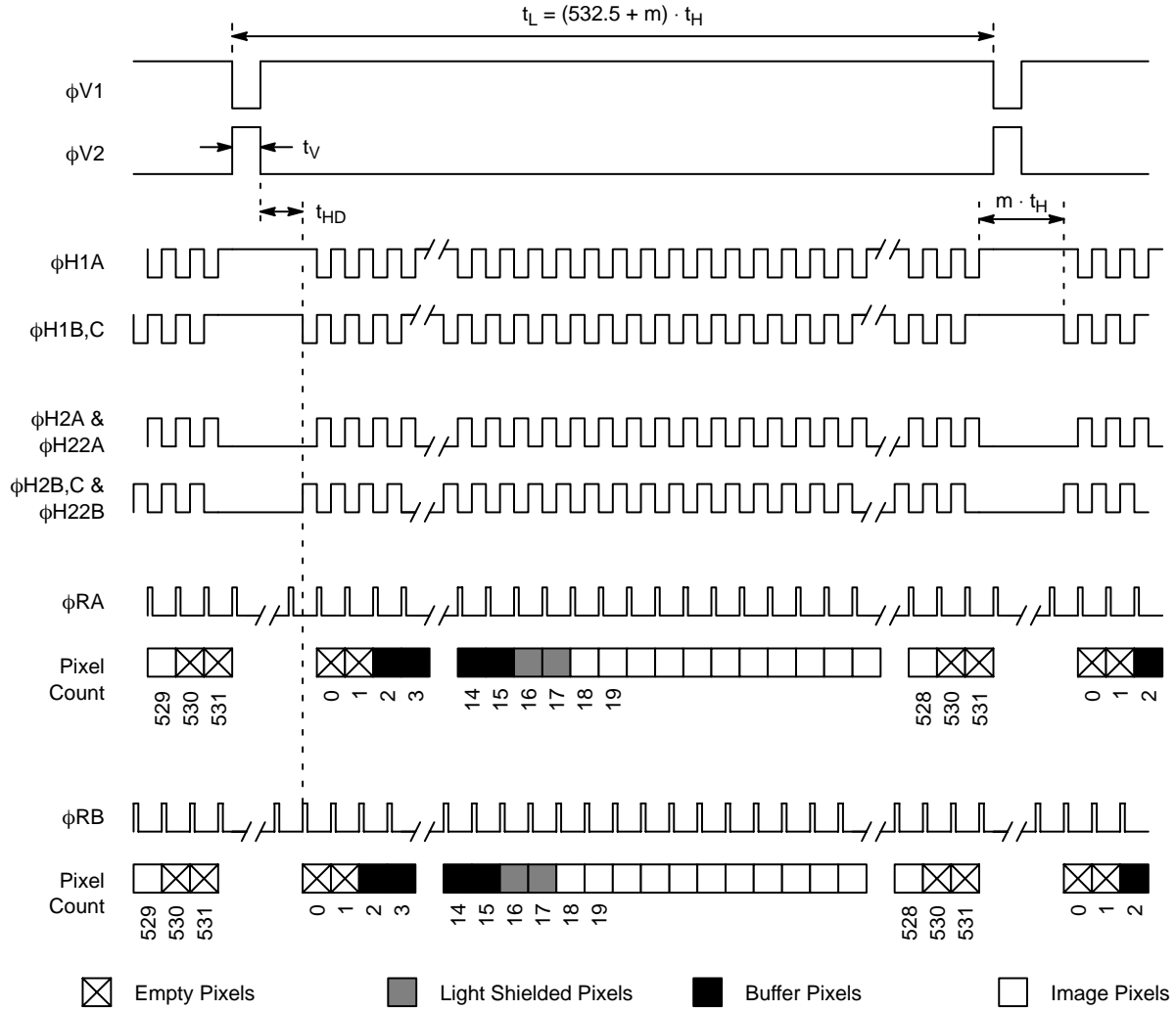

Figure 11. Line Timing – 1x1 – Dual Output, Out-of-Phase



Pixel Timing – 1x1

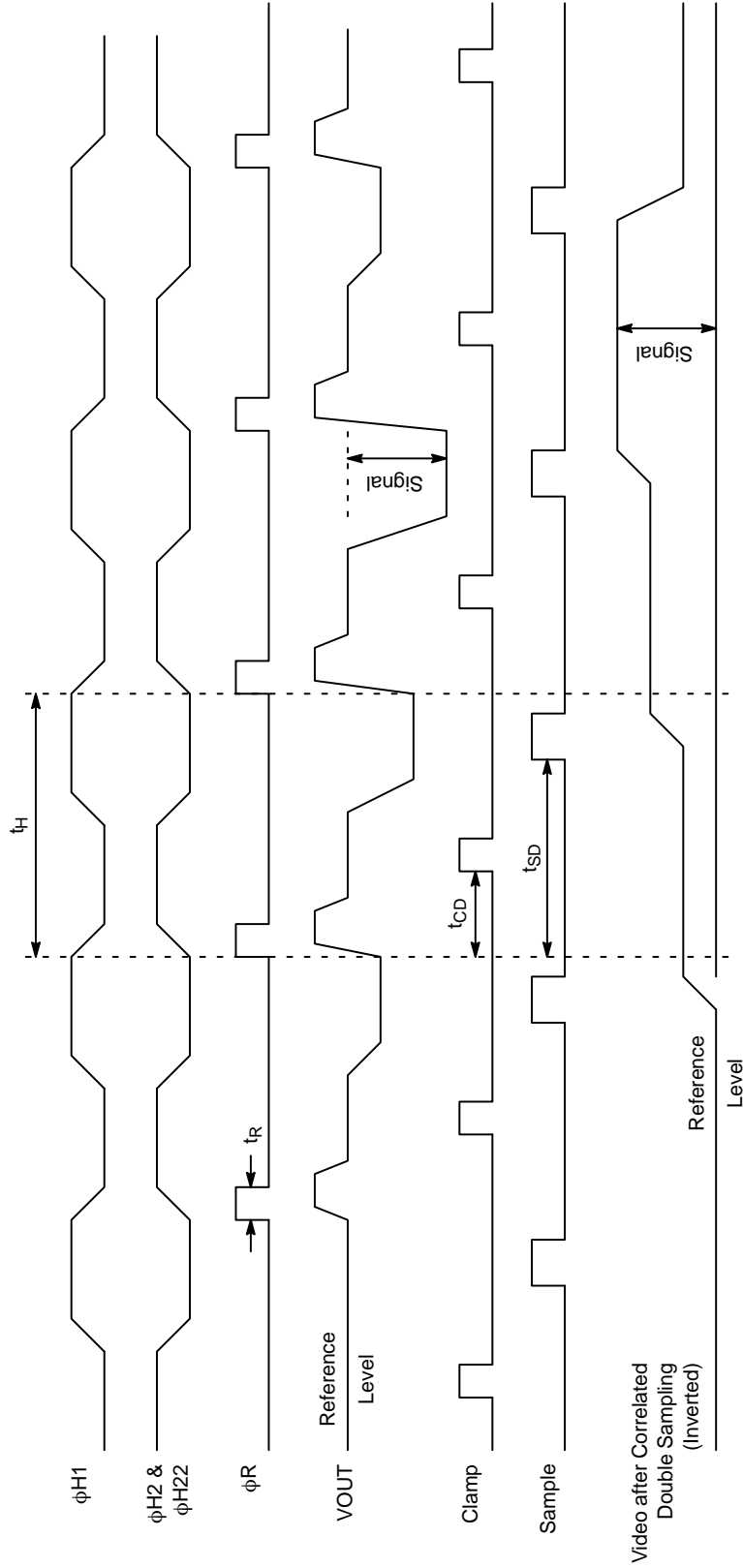

Figure 12. Pixel Timing – 1x1

Frame Timing – 2x2

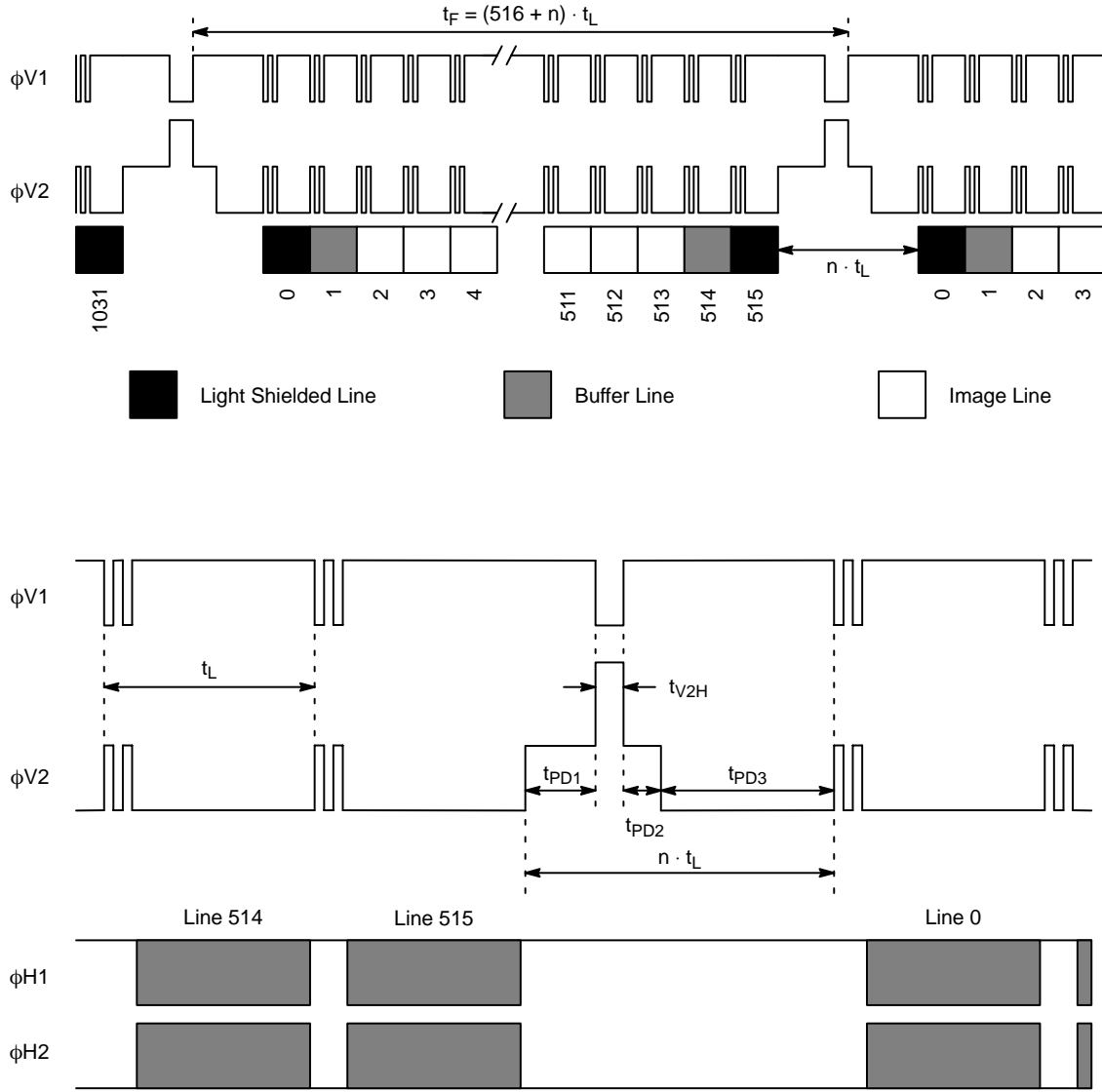

Figure 13. Frame Timing – 2x2

Line Timing – 2x2

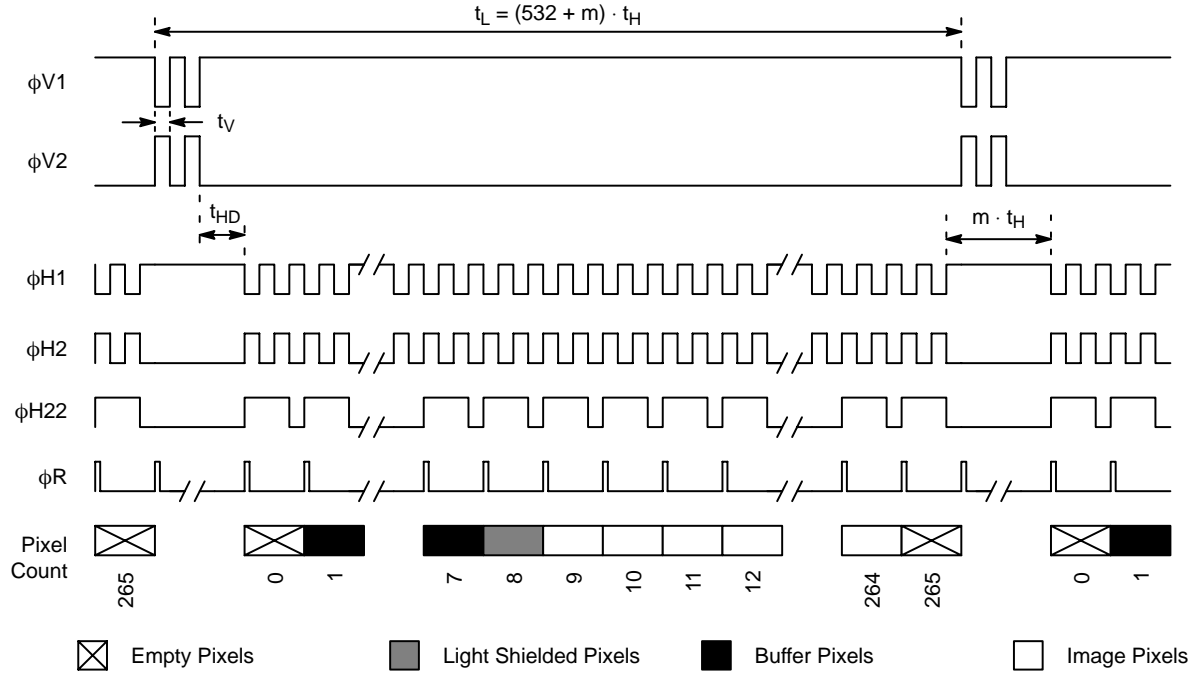

Figure 14. Line Timing – 2x2

Pixel Timing – 2x2

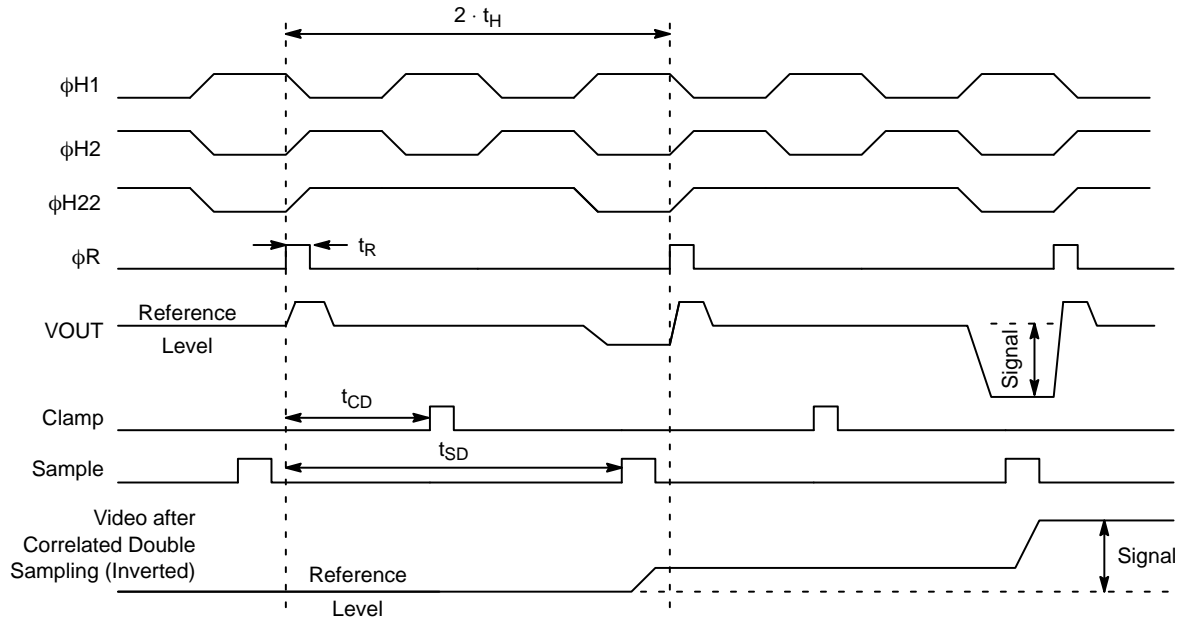
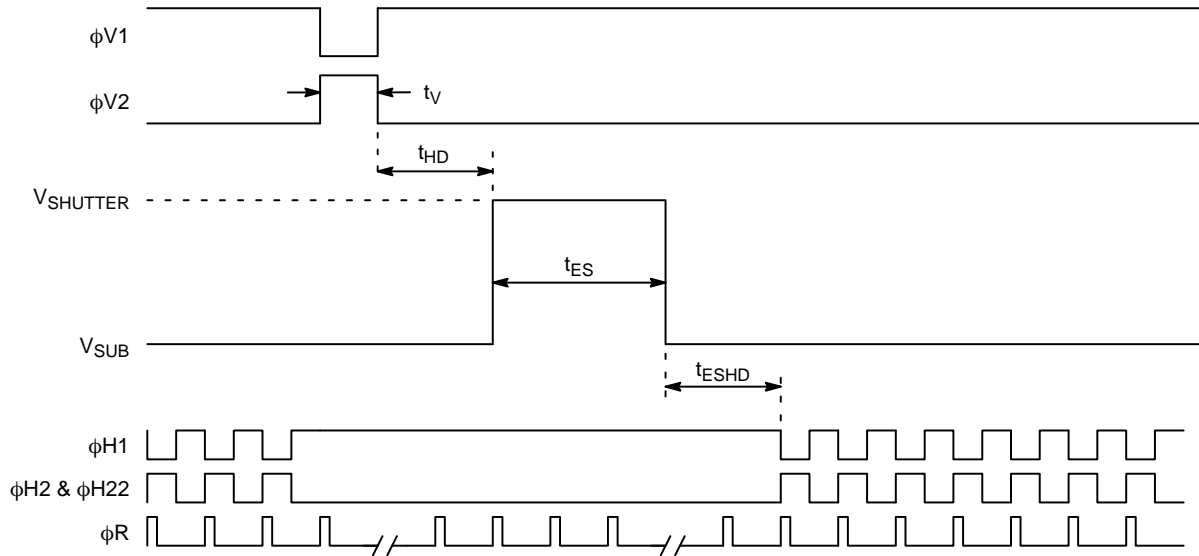

Figure 15. Pixel Timing – 2x2

**Electronic Shutter Line Timing**



**Figure 16. Electronic Shutter Line Timing**

**Integration Time Definition**

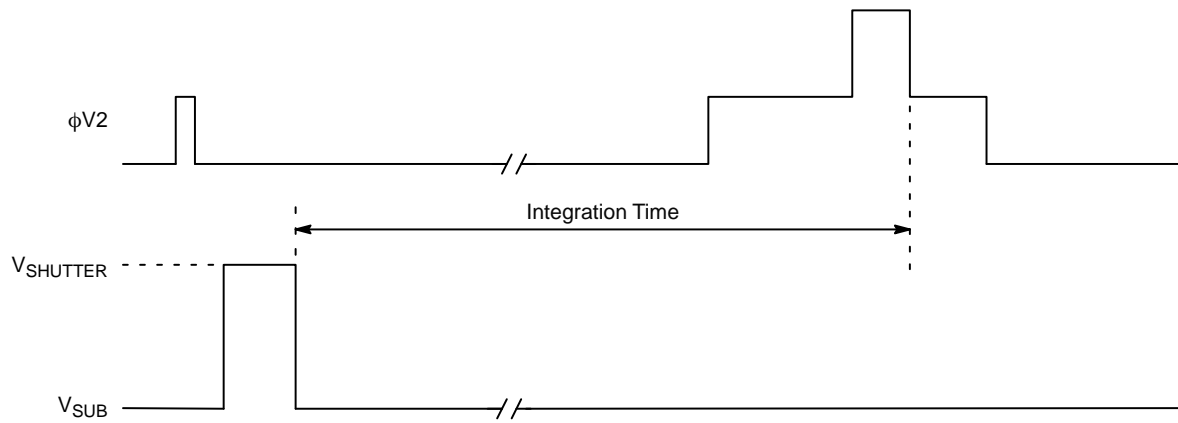

**Figure 17. Integration Time Definition**

**REFERENCES**

For information on ESD and cover glass care and cleanliness, please download the *Image Sensor Handling and Best Practices* Application Note (AN52561/D) from [www.onsemi.com](http://www.onsemi.com).

For information on environmental exposure, please download the *Using Interline CCD Image Sensors in High Intensity Lighting Conditions* Application Note (AND9183/D) from [www.onsemi.com](http://www.onsemi.com).

For information on soldering recommendations, please download the *Soldering and Mounting Techniques Reference Manual* (SOLDERRM/D) from [www.onsemi.com](http://www.onsemi.com).

For quality and reliability information, please download the *Quality & Reliability Handbook* (HBD851/D) from [www.onsemi.com](http://www.onsemi.com).

For information on device numbering and ordering codes, please download the *Device Nomenclature* technical note (TND310/D) from [www.onsemi.com](http://www.onsemi.com).

For information on Standard terms and Conditions of Sale, please download [Terms and Conditions](#) from [www.onsemi.com](http://www.onsemi.com).

# KAI-1003

## MECHANICAL DRAWINGS

### Completed Assembly

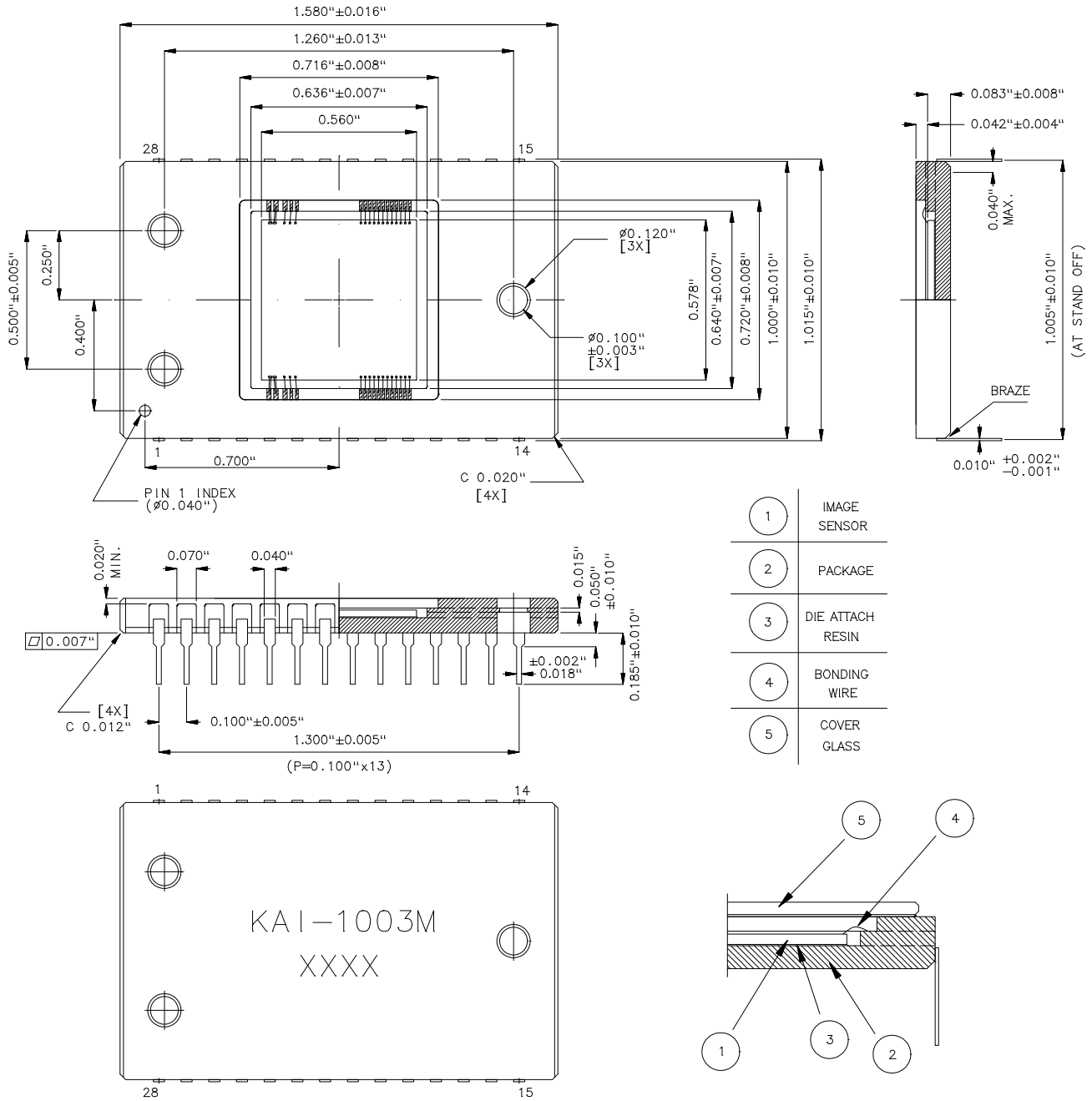

Figure 18. Completed Assembly

## Cover Glass Specification

**Table 14. COVER GLASS SPECIFICATION**

Item	Specification
Substrate	Schott D263T eco or equivalent
Thickness	0.030" ± 0.002"
Coating	Double-sided anti-reflecting coating on a 0.660" × 0.660" square for a transmission minimum of 98% in the 400 to 700 nm wavelength
Scratch	No scratch greater than 10 microns

### Cover Glass Care and Cleanliness:

1. The cover glass is highly susceptible to particles and other contamination. Perform all assembly operations in a clean environment.
2. Touching the cover glass must be avoided
3. Improper cleaning of the cover glass may damage these devices. Improper cleaning of the cover glass may damage these devices. Refer to Application Note *Image sensor Handling and Best Practices*.

ON Semiconductor and the  are registered trademarks of Semiconductor Components Industries, LLC (SCILLC) or its subsidiaries in the United States and/or other countries. SCILLC owns the rights to a number of patents, trademarks, copyrights, trade secrets, and other intellectual property. A listing of SCILLC's product/patent coverage may be accessed at [www.onsemi.com/site/pdf/Patent-Marking.pdf](http://www.onsemi.com/site/pdf/Patent-Marking.pdf). SCILLC reserves the right to make changes without further notice to any products herein. SCILLC makes no warranty, representation or guarantee regarding the suitability of its products for any particular purpose, nor does SCILLC assume any liability arising out of the application or use of any product or circuit, and specifically disclaims any and all liability, including without limitation special, consequential or incidental damages. "Typical" parameters which may be provided in SCILLC data sheets and/or specifications can and do vary in different applications and actual performance may vary over time. All operating parameters, including "Typicals" must be validated for each customer application by customer's technical experts. SCILLC does not convey any license under its patent rights nor the rights of others. SCILLC products are not designed, intended, or authorized for use as components in systems intended for surgical implant into the body, or other applications intended to support or sustain life, or for any other application in which the failure of the SCILLC product could create a situation where personal injury or death may occur. Should Buyer purchase or use SCILLC products for any such unintended or unauthorized application, Buyer shall indemnify and hold SCILLC and its officers, employees, subsidiaries, affiliates, and distributors harmless against all claims, costs, damages, and expenses, and reasonable attorney fees arising out of, directly or indirectly, any claim of personal injury or death associated with such unintended or unauthorized use, even if such claim alleges that SCILLC was negligent regarding the design or manufacture of the part. SCILLC is an Equal Opportunity/Affirmative Action Employer. This literature is subject to all applicable copyright laws and is not for resale in any manner.

### PUBLICATION ORDERING INFORMATION

**LITERATURE FULFILLMENT:**

Literature Distribution Center for ON Semiconductor  
 19521 E. 32nd Pkwy, Aurora, Colorado 80011 USA  
**Phone:** 303-675-2175 or 800-344-3860 Toll Free USA/Canada  
**Fax:** 303-675-2176 or 800-344-3867 Toll Free USA/Canada  
**Email:** [orderlit@onsemi.com](mailto:orderlit@onsemi.com)

**N. American Technical Support:** 800-282-9855 Toll Free  
 USA/Canada  
**Europe, Middle East and Africa Technical Support:**  
 Phone: 421 33 790 2910  
**Japan Customer Focus Center**  
 Phone: 81-3-5817-1050

**ON Semiconductor Website:** [www.onsemi.com](http://www.onsemi.com)  
**Order Literature:** <http://www.onsemi.com/orderlit>  
 For additional information, please contact your local Sales Representative