

**Air Powered
Crimp Tool Head
NylaKrimp™**

**Application Tooling
Specification Sheet**

**Order No. 64005-6500
Engineering No. AT 8200**

FEATURES

- Quick-change tool head for the 19279-0001 (AT-200)
- Tooling kit is interchangeable with other kits in the 64001 and 64003 Series
- Pneumatic powered crimp tools help reduce fatigue and discomfort from repetitive manual crimping

SCOPE

Products: NylaKrimp™ Insulated butt splices, Funnel entry butt splices and parallel splices, 14-16 AWG.

Testing

Mechanical

The tensile test, or pull test, is a means of evaluating the mechanical properties of the crimped connections. The following charts show the UL specifications for various wire sizes. The tensile strength is shown in pounds and indicates the minimum acceptable force to break or separate the terminal from the conductor.

Wire Size (AWG)	*UL - 486 C
16	15
14	25

*UL - 486 C - Butt Splices

The following is a partial list of the product part numbers and their specifications that this tool is designed to run. We will be adding to this list and an up to date copy is available on www.molex.com.

Wire Size: 14-16 AWG 2.00-1.30mm ²					
Terminal No.	Terminal Eng. No. (REF)	Wire Strip Length		Insulation Diameter Maximum	
		In	mm	In	mm
19202-0019	B-931-DK	.313	7.94	.199/.185 Funnel	5.05/4.70
19202-0026	BS-942	.313	7.94	0.199	5.05
19202-0131	BS-942-B	.313	7.94	0.199	5.05
19202-0027	BS-942-DK	.313	7.94	0.199	5.05
19207-0004	BS-N-304	.281	7.14	0.15	3.68

Caution: Never operate this tool without the supplied safety shield in place. Never place fingers in the tool nests.

OPERATION

Refer to the instruction manual for the 19279-0001 (AT200) for mounting this crimp tool head.

Crimping Terminals

1. Insert the wire into the butt splice; the wires end should butt up against the tab in the terminal. See figure 2. Hold the air crimp tool with the backside facing the operator. Insert the butt splice and the wire into the nest. See Figure 1.
2. Press lever on air tool. Release it after jaws have closed.

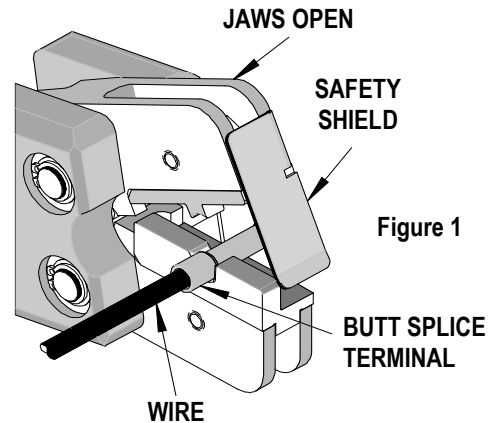

Figure 1

Note: The tamper proof ratchet action will not release the tool until it has been fully closed.

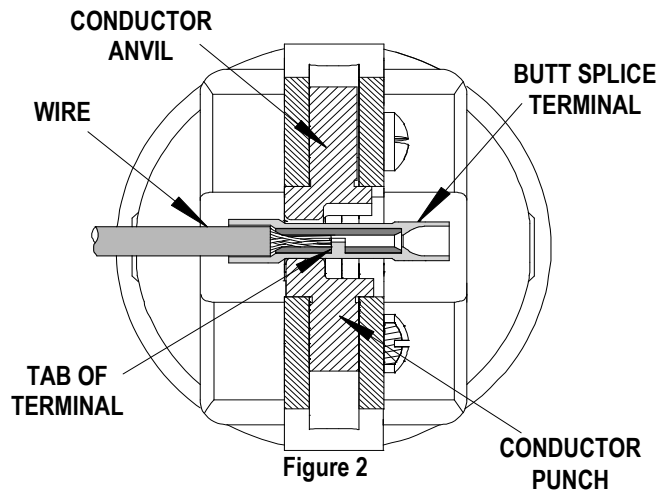

Figure 2

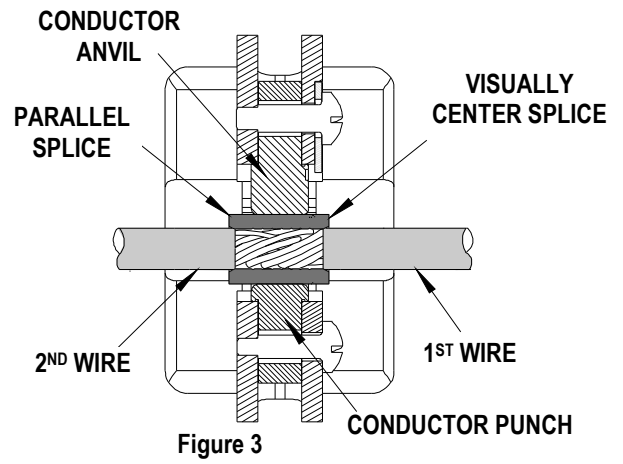

Figure 3

3. Remove the crimped splice. Inspect for proper crimp location.
4. Rotate the butt splice terminal 180°, so that the opposite end of splice is in the nest.
5. Repeat steps 1 thru 4.
6. When crimping Parallel Splices, insert the 1st wire into one end of splice then insert the 2nd wire into the opposite end of the parallel splice. This procedure will crimp both wires at the same time. Make sure the wires are fully seated into the parallel splice. Position the splice and the wires in the nest with conductor crimp on the conductor barrel of the splice. The splice should be approximately centered inside the tooling nest. See Figure 3. Cycle the tool.
7. Molex offers a Crimp Inspection Handbook for closed barrel industrial product. See our website or contact your sales engineer

Note: Whenever crimping without the locator, make sure the seam of the terminal is oriented up or down in the tool if using unbrazed product, as this will provide higher pull force values.

Maintenance

It is recommended that each operator of the tool be made aware of, and responsible for, the following maintenance steps:

1. Remove dust, moisture and other contaminants with a clean brush, or soft, lint-free cloth.
2. Do not use any abrasive materials that could damage the tool.
3. Make certain all pins; pivot points and bearing surfaces are protected with a thin coat of high quality machine oil. Do not oil excessively. This tool was engineered for durability but like any fine piece of equipment it needs cleaning and lubrication for a maximum service life of trouble-free crimping. Use a light oil such as 30 weight automotive oil at the oil points shown in Figure 4, every 5,000 crimps or monthly will significantly enhance the tool life and ensure a stable calibration.
4. When tool is not in use store the tool in a clean, dry area.

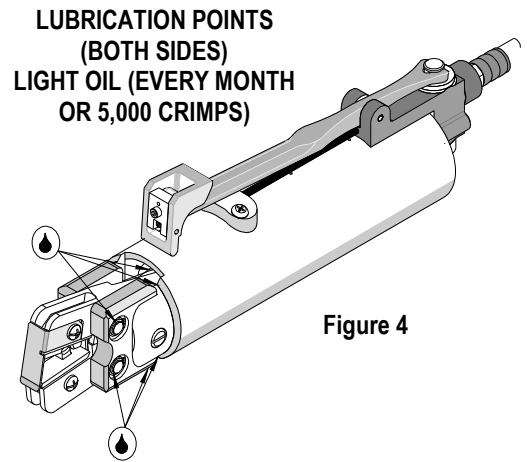
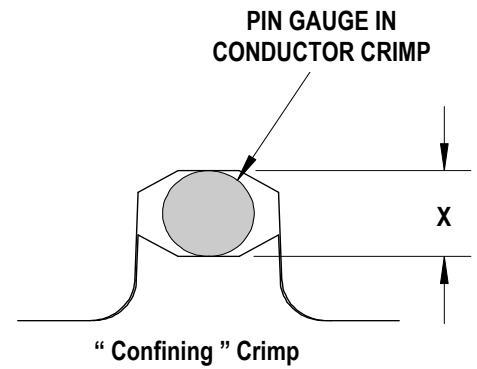

Figure 4

Tool Calibration

A Certificate of Calibration (See last page) was supplied with the tool. To recalibrate this tool, pin gauge measurements should be taken in each conductor nest and compared to this chart. The tool should be lubricated prior to recalibration to ensure consistent measurements.



Nest Color Code	Wire Range		"X" Dimension Conductor Crimp			Crimp Inspection Marking
	AWG	mm ²	Mean	Go	No Go	
Blue	14-16	2.00-1.30	.094	.091	.102	N/A

Warranty

This tool is for electrical terminal crimping purposes only. This tool is made of the best quality materials. All vital components are long life tested. All tools are warranted to be free of manufacturing defects for a period of **30 days**. Should such a defect occur, we would repair or exchange the tool free of charge. This repair or exchange will not be applicable to alter, misused, or damaged tools.

CAUTION: Molex crimp specifications are valid only when used with Molex terminals, applicators and tooling.

PARTS LIST

Item	Order No	Description	Quantity
	64005-6500	Crimp Tool Head	Figure 5
1	64005-0000	Basic Air Tool Head	1
2	64001-6570	Tooling Kit	1
Tooling Kit Only			
3	64001-6501	Conductor Punch	1
4	64001-6502	Conductor Anvil	1

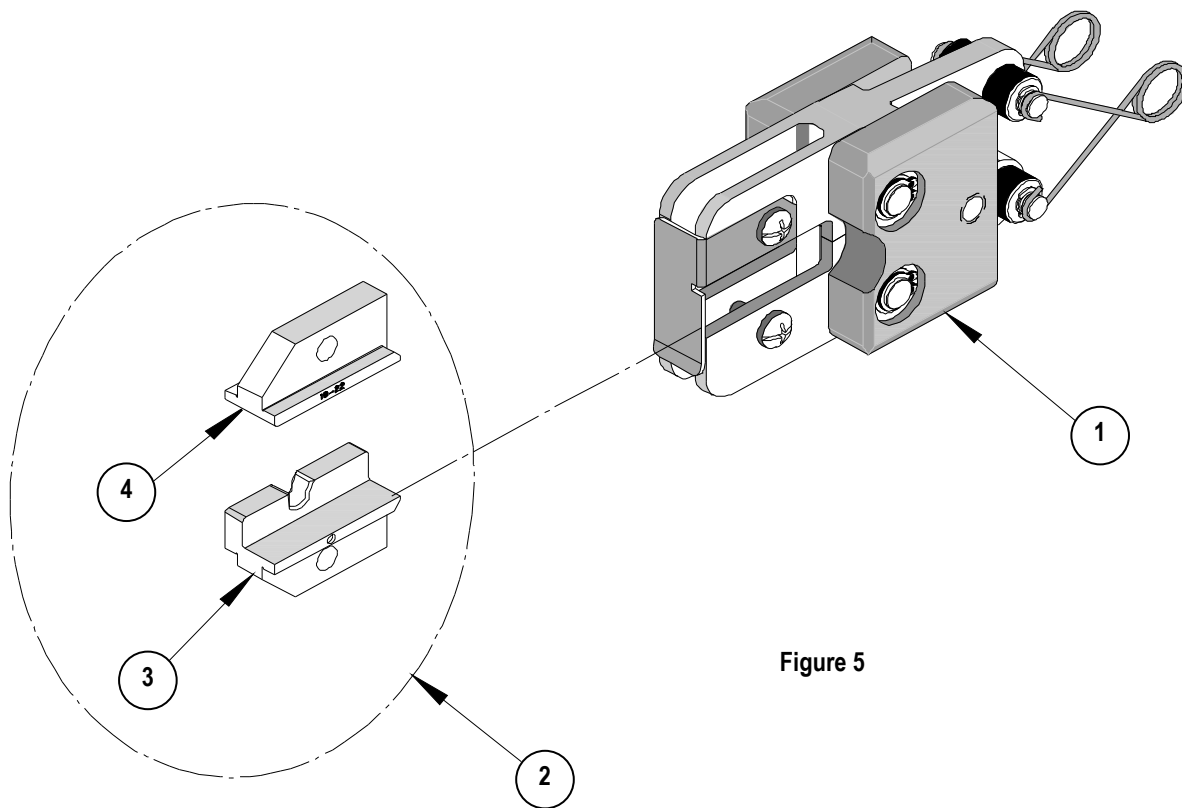

Figure 5

Parts List (Continued)

Item	Order No.	Description	Quantity
	64005-0000	Basic Air Tool Head	Figure 6
1	64005-0103	Nose Guard	1
2	64000-0077	Repair Kit (Springs, Rods Pivots ,Rings, and Washers)	1
3	N/A	M4 by 12 Long Freedrive Pan Head Screw	1**
4	N/A	M4 by 30 Long Freedrive Pan Head Screw	1**
5	N/A	3/16" by 3/8" Long Dowel Pin	1**

** Available from an Industrial supply company such as MSC (1-800-645-7270).

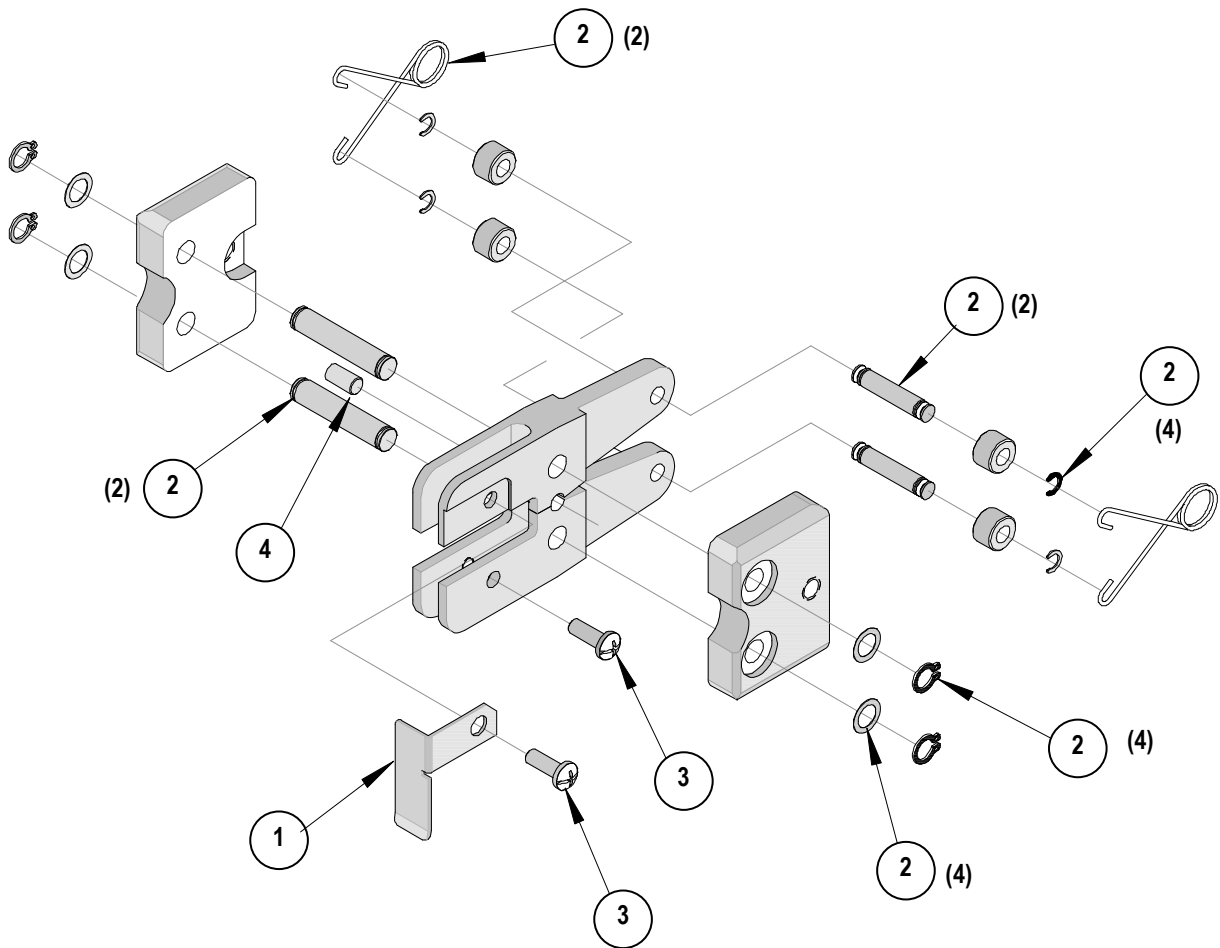
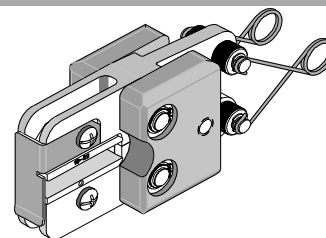

Figure 6

**Air Powered
Crimp Tool Head
NylaKrimp™**



Certificate of Calibration



**Order No. 64005-6500
Engineering No. AT 8200**

Tool Order Number _____

Tool Eng. Number _____

Tool Revision _____

Serial Number _____

Date of Manufacture _____

Pin Gauge of Conductor Nest/Nests or Slug height if the nest is the "F" Crimp style.

Range Conductor Nest # 1 = _____ - Actual = _____ -

Technician _____ -

Date of Calibration _____ -

Calibration should be done every 5,000 cycles or 3 months.
Tools should be lubricated during this operation.

Visit our Web site at <http://www.molex.com>