

SMT POWER INDUCTORS

Shielded Drum Core - PL95XX Series

Ruggedized



- ⊗ Height: 0.122 inches (3.1mm) Max
- ⊗ Footprint: 0.256 inches x 0.256 inches (6.5mm x 6.5mm) Max
- ⊗ Inductance Range: 2.15μH to 85.39μH
- ⊗ Current Rating: up to 2.60A
- ⊗ Moisture Sensitivity Level: 1

Electrical Specifications @ 25 °C – Operating Temperature – 55 °C to +130 °C

Part Numbers	Inductance @I _{rated} (μH TYP)	I _{rated} ² (A)	DCR (mΩ)		Inductance MAX	Saturation ³ @OADC (μH)	Current (A) @25°C	Heating ⁴ Current (A)
			TYP					
PL9501	2.15	2.60	15.3		17.6	2.5*	2.60	3.45
PL9502	2.58	2.30	16.6		20.3	3.3*	2.30	3.31
PL9503	3.43	2.10	22.5		27.0	4.0*	2.10	2.84
PL9504	4.63	1.85	24.9		31.1	5.0*	1.85	2.70
PL9505	5.22	1.70	32.3		41.9	6.0*	1.70	2.37
PL9506	6.57	1.50	37.9		49.9	8.0*	1.50	2.19
PL9507	8.65	1.30	45		54	10	1.30	2.01
PL9508	9.78	1.20	59		72	12	1.20	1.76
PL9509	12.13	1.10	66		82	15	1.10	1.65
PL9510	15.23	1.05	88		102	18	1.05	1.44
PL9511	18.70	0.95	103		119	22	0.95	1.33
PL9512	21.54	0.85	114		146	27	0.85	1.26
PL9513	27.71	0.76	155		183	33	0.76	1.08
PL9514	33.57	0.68	193		210	39	0.68	0.97
PL9515	40.15	0.60	196		230	47	0.60	0.96
PL9516	49.68	0.55	248		305	56	0.55	0.86
PL9517	60.66	0.48	278		351	68	0.48	0.81
PL9518	74.71	0.45	323		419	82	0.45	0.75
PL9519	85.39	0.40	417		520	100	0.40	0.66

*Inductance at OADC tolerance on indicated part numbers is ±30%; tolerance is ±20% on all other parts.

Optional Tape & Reel packaging can be ordered by adding a "T" suffix to the part number (i.e. PL9501 becomes **PL9501T**).

Notes from Tables

1. Temperature of the component (ambient plus temperature rise) must be within specified operating temperature range.
2. The rated current as listed is either the saturation current or the heating current depending on which value is lower.
3. The saturation current is the current which causes the inductance to drop to 75% of its initial inductance at zero bias. This current is determined by placing the component at room ambient (25°C), and applying a short duration pulse current (to eliminate self-heating effects) to the component.
4. The heating current is the DC current, which causes the temperature of the part to increase by approximately 40°C. This current is
5. determined by extending the terminals of the component with 30mm length 28 gauge buss wires and applying the current to the device for 30 minutes. The temperature is measured by placing the thermo-couple between the winding and the shield.
6. In high volt*time applications, additional heating in the component can occur due to core losses in the inductor which may necessitate derating the current in order to limit the temperature rise of the component. In order to determine the approximate total loss (or temperature rise) for a given application, both copper losses and core losses should be taken into account.



SMT POWER INDUCTORS

Shielded Drum Core - PL95XX Series
Ruggedized



Mechanical

Electrical Schematic

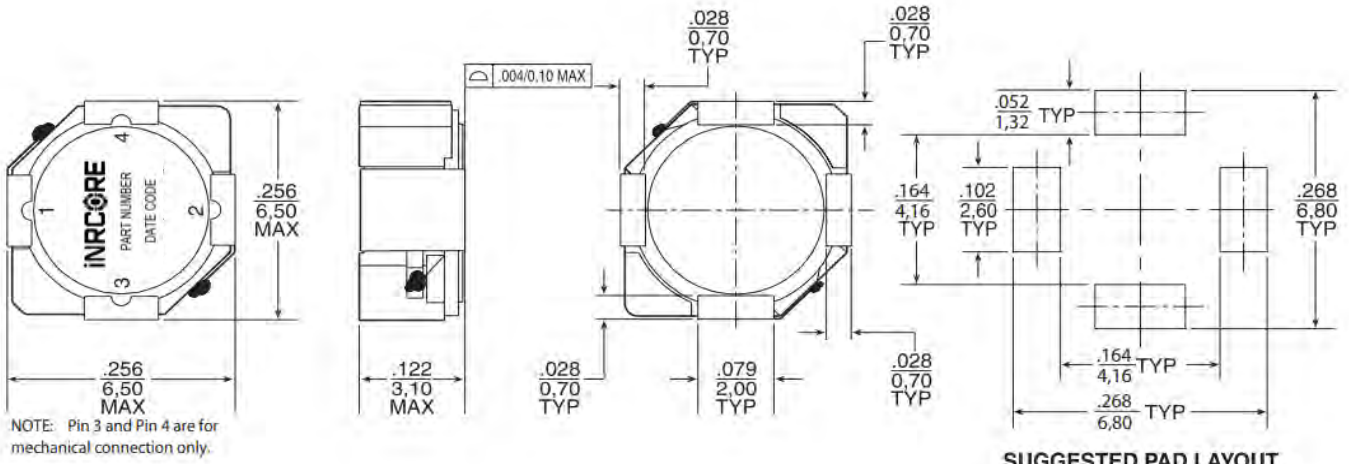

Schematic

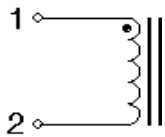

TAPE & REEL LAYOUT

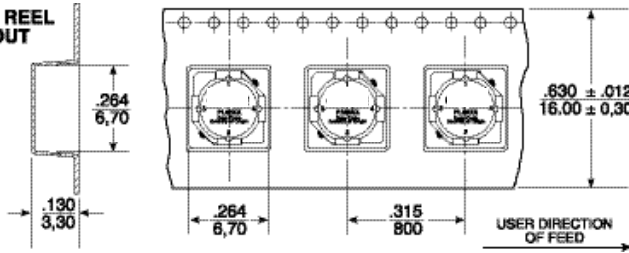

Percentage of the initial inductance

Inductance vs. Current Characteristics

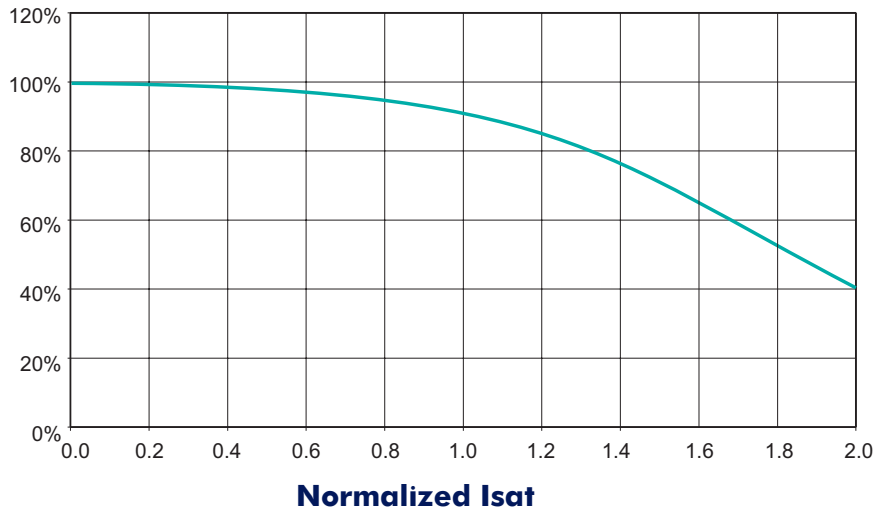

Tin/Lead Recommended Reflow Profile (Based on J-STD-020D)

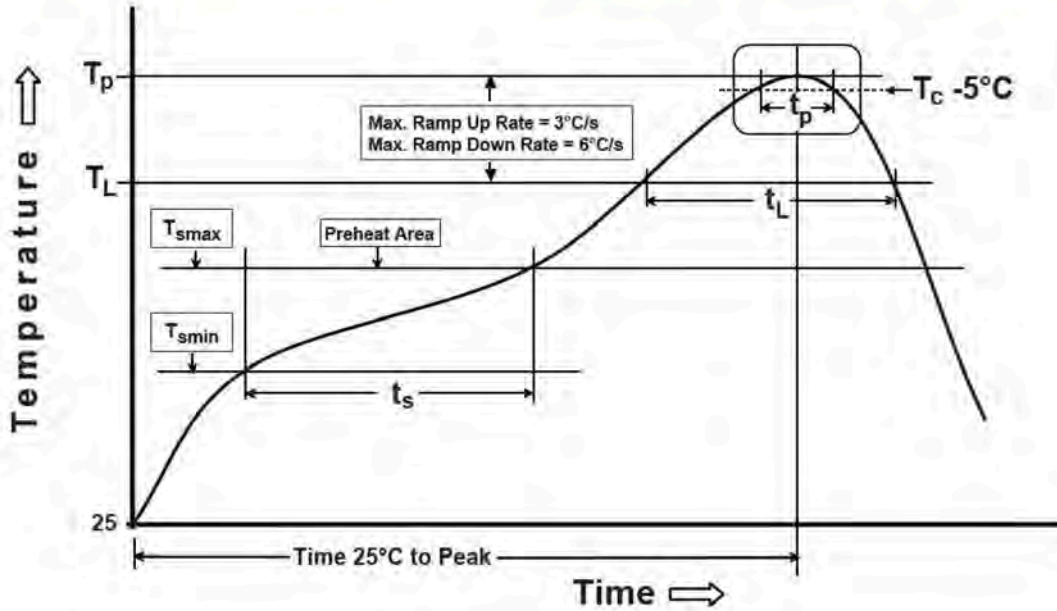

T _S MIN (°C)	T _S MAX (°C)	T _L (°C)	T _P (°C MAX)	t _S (s)	t _L (s)	t _P (s MAX)	Ramp-up rate (T _L to T _P)	Ramp-down rate (T _P to T _L)	Time 25°C to peak temperature (s MAX)
100	150	183	235	60-120	60-150	20	3°C/s MAX	6°C/s MAX	360

Notes:

1. All temperatures measured on the package leads.
2. Maximum times of reflow cycle: 2.

For More Information

iNRCORE, LLC
 311 Sinclair Road Bristol,
 PA 19007-6812 U.S.A
 Tel: + 1.215.781.6400
 Fax: +1.215.7816430

Global Sales Representatives and Locations:
<http://www.inrcore.com>

Performance warranty of products offered on this data sheet is limited to the parameters specified. Data is subject to change without notice. Other brand and product names mentioned herein may be trademarks or registered trademarks of their respective owners. © Copyright, 2020. iNRCORE, LLC. All rights reserved.

