

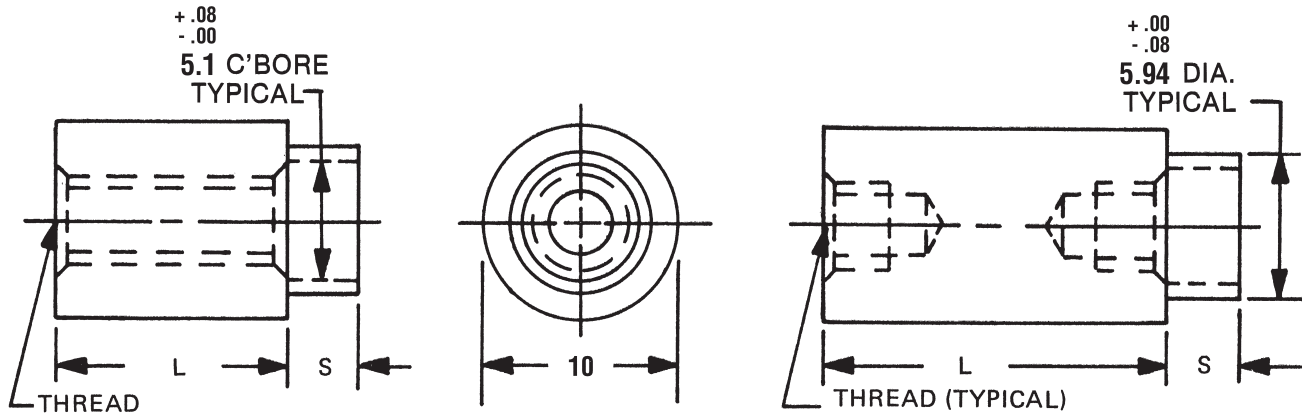

10mm ROUND SWAGE STANDOFFS



L = STANDOFF LENGTH
 S = SHANK LENGTH
 P = BOARD THICKNESS

See page iv for installation information

See page 7M for thread depth chart
 See page 6M for finish codes
 For non-standard parts contact Sales Office

SWAGE TOOLING		
PUNCH	ANVIL	LENGTH
P5	AR-82	3-5
	AR-83	6-12
	AR-84	13-18
	AR-85	19-25

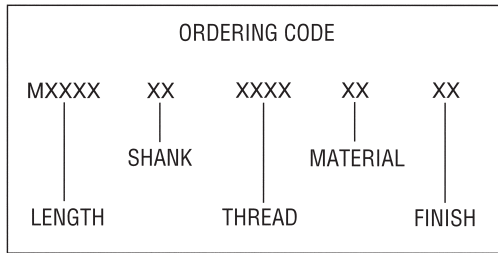

SWAGE/PANEL CODE		
± .08	S	P
1.9	A	.8
2.7	B	1.6
3.4	C	2.4
4.2	D	3.2

LENGTH	PART NO.
3	M1605
4	M1606
5	M1607
6	M1608
7	M1609
8	M1610
9	M1611
10	M1612
11	M1613
12	M1614
13	M1615
14	M1616

LENGTH	PART NO.
15	M1617
16	M1618
17	M1619
18	M1620
19	M1621
20	M1622
21	M1623
22	M1624
23	M1625
24	M1626
25	M1627

THREAD	CODE
M3.5x0.6	3506
M4x0.7	4007
M5x0.8	5008

MATERIAL	CODE	RoHS
Aluminum	AL	YES
Brass	B	YES
Stainless Steel	SS	YES
Steel	S	YES



95 Silvermine Road, Seymour, Ct. 06483 Phone: 203-888-2133 Fax: 203-888-9860
 e-mail : info@rafhdwe.com Web: www.rafhdwe.com

