

**NOTES: UNLESS OTHERWISE SPECIFIED**

1. CORNERS DRAWN SHARP TO BE R.005 MAXIMUM.
2. EXTERIOR SURFACE TEXTURE TO BE LIGHT EDM FINISH. EQUIVALENT TO MT-11010.
3. INTERIOR SURFACE TEXTURE: NONE.
4. ALL INSIDE RADII .010R. UNLESS OTHERWISE SPECIFIED.
5. ALL EXTERNAL DIMENSIONS AFFECTED BY THE DRAFT APPLY AT THE LARGE END OF THE FEATURE, AND ALL INTERNAL FEATURES AFFECTED BY THE DRAFT APPLY AT THE SMALL END OF THE FEATURE UNLESS OTHERWISE SPECIFIED.
6. 1 DEGREE DRAFT IN THE DIRECTION OF PULL IS PERMISSIBLE UNLESS OTHERWISE SPECIFIED.
7. MATERIAL / COLOR: ABS PLASTIC IS STANDARD IN BLACK OR WHITE. CUSTOM MATERIALS AND COLORS MAY BE AVAILABLE UPON REQUEST FOR QUOTE.
8. PCB SIZES ARE RECOMMENDATIONS ONLY. FINAL SIZES AND VERIFICATION OF ITS FIT ARE THE SOLE RESPONSIBILITY OF EACH CUSTOMER.
9. CUSTOM LABEL RECESSES MAY BE AVAILABLE UPON REQUEST FOR QUOTE.
10. ASSEMBLY SCREWS PROVIDED. BATTERY CONTACTS SOLD SEPERATELY. PCB SCREWS ARE CUSTOMER SUPPLIED.
11. ANY SPECIFIC DIMENSIONS NOT PROVIDED HERE CAN BE OBTAINED FROM OUR SOLID MODELS (.STEP), AVAILABLE AT OUR WEBSITE. MODIFIED CUSTOMER MODELS ARE AVAILABLE UPON REQUEST.

R E V I S I O N

REV.	DRAWN BY	ECO No	DESCRIPTION	DATE	APPROVED
1	M BOYER	---	RELEASE	27-Jun-09	D.C.
3	M BOYER	3109	CONSOLIDATE ALL 442710 CONFIG INTO ONE DOCUMENT	05-Sep-09	D.C.
4	M BOYER	3809	INCREASE HATCH RELIEF TOLERANCE	27-Oct-09	D.C.
4.1	M BOYER	0710	UPDATE FORMAT	26-Mar-10	D.C.
4.2	M BOYER	0712	UPDATE CONFIG AND REMOVE LCD CONFIG	28-Feb-12	D.C.
4.3	R CRUZ	1114	REMOVE LCD CONFIG & UPDATE NOTES	19-Mar-14	D.C.
4.4	R CRUZ	3314	REVISE CONFIGURATION TABLE	18-Jun-14	D.C.
4.5	R CRUZ	03615	ADD LABEL RECESS DIMENSIONS ON COVER	06-Aug-15	

442710(x) CONFIGURATIONS			
	-Blank	-K	-WP*
442710 COVER	1	1	
442710 BATTERY BASE	1	1	
442710 WALL PLATE		1	1
442710 HATCH	1		
442710 HATCH (Modified)		1	
#4 HiLo SCREW 1.00"		1	1
#4 HiLo SCREW .750"	2	1	
#4 HiLo SCREW .500"	2	2	
SINGLE AA CLIP	2*	2*	
DOUBLE AA CLIP	1*	1*	

\* = SOLD SEPERATELY

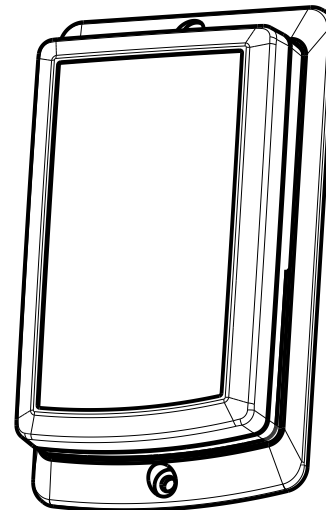

SCALE 0.500

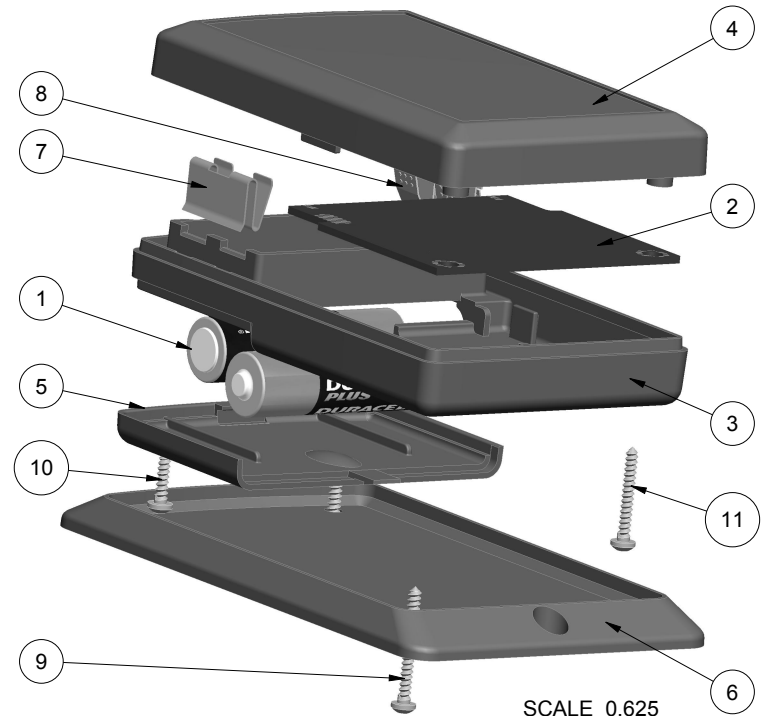

SCALE 0.625

ITEM	FILE NAME	DESCRIPTION	MATERIAL	COLOR	QTY.
11	NO_4_750_SCREW	HiLo4 x 3/4"	S-HiLo x 3/4"	ZINC PLATED	1
10	NO_4_500_SCREW	HiLo4 x 1/2"	S-HiLo x 1/2"	ZINC PLATED	1
9	NO_4_1000_SCREW	HiLo4 x 1"	S-HiLo x 1.0"	ZINC PLATED	2
8	SM_CLIP	PartNo: 209	SINGLE AA	NICKEL PLATED	2
7	LG_CLIP	PartNo:210	DOUBLE AA	NICKEL PLATED	1
6	442710-WALL	442710 WALL - STANDARD	ABS	BLACK or WHITE	1
5	442710-HATCH	442710 HATCH - STANDARD	ABS	BLACK or WHITE	1
4	442710-COVER	442710 COVER - STANDARD	ABS	BLACK or WHITE	1
3	442710-BASE	442710 BASE - STANDARD	ABS	BLACK or WHITE	1
2	442710-PCB	REFERENCE ONLY	CUSTOMER SUPPLIED	.062" THICK	1
1	AA_BATTERY	REFERENCE ONLY	CUSTOMER SUPPLIED	-	2

BILL OF MATERIALS

<p>THIRD ANGLE PROJECTION</p> <p>DO NOT SCALE DRAWING</p>	<p>TOLERANCES: UNLESS OTHERWISE SPECIFIED DIMENSIONS ARE IN U.S. INCHES.</p> <p>X.XX = .015 X.XXXX = .001</p> <p>X.XXX = .010 X.X" = 1°</p>	<p><b>NEW AGE ENCLOSURES</b></p> <p>2240 South Thornburg Street Santa Maria, CA. 93455</p> <p>ph. (805) 595-1310 fax (805) 595-1024</p> <p><a href="http://www.newageenclosures.com">www.newageenclosures.com</a></p>																							
	<p><b>NEW AGE ENCLOSURES</b></p> <p>Customer's Part No: 442710X</p>		<p><b>MED HANDHELD - STANDARD</b></p> <p><b>SXX-442710X-XXXX</b></p>																						
<p>NOTICE: THE INFORMATION AND DATA CONTAINED HEREIN IS CONSIDERED PROPRIETARY TO ALLTEC INTEGRATED MFG INC &amp; SHALL REMAIN THE EXCLUSIVE PROPERTY OF ALLTEC INTEGRATED MFG INC. THE HOLDER WILL ASSUME CUSTODY AND CONTROL THAT THIS DOCUMENT WILL NOT BE COPIED, REPRODUCED, OR DISCLOSED WITHOUT THE EXPRESS WRITTEN CONSENT OF ALLTEC INTEGRATED MFG INC. POSSESSION OF THIS DOCUMENT DOES NOT CONSTITUTE A GRANT TO MANUFACTURE ANY ITEMS.</p> <p>© 2017</p>	<table border="1"> <tr> <td>APPROVAL</td> <td>BY</td> <td>DATE</td> </tr> <tr> <td>CHECK</td> <td></td> <td></td> </tr> <tr> <td>ENG.</td> <td></td> <td></td> </tr> </table>	APPROVAL	BY	DATE	CHECK			ENG.			<table border="1"> <tr> <td>SCALE</td> <td>AS NOTED</td> </tr> </table>	SCALE	AS NOTED	<table border="1"> <tr> <td>DRAWN BY</td> <td>2009-Jun-27</td> </tr> <tr> <td>SIZE</td> <td>A</td> </tr> </table>	DRAWN BY	2009-Jun-27	SIZE	A	<table border="1"> <tr> <td>DRAWING NAME</td> <td>442710X_R4_5</td> </tr> <tr> <td>SHEET</td> <td>1 OF 10</td> </tr> <tr> <td>REV.DOC</td> <td>4.5</td> </tr> </table>	DRAWING NAME	442710X_R4_5	SHEET	1 OF 10	REV.DOC	4.5
APPROVAL	BY	DATE																							
CHECK																									
ENG.																									
SCALE	AS NOTED																								
DRAWN BY	2009-Jun-27																								
SIZE	A																								
DRAWING NAME	442710X_R4_5																								
SHEET	1 OF 10																								
REV.DOC	4.5																								

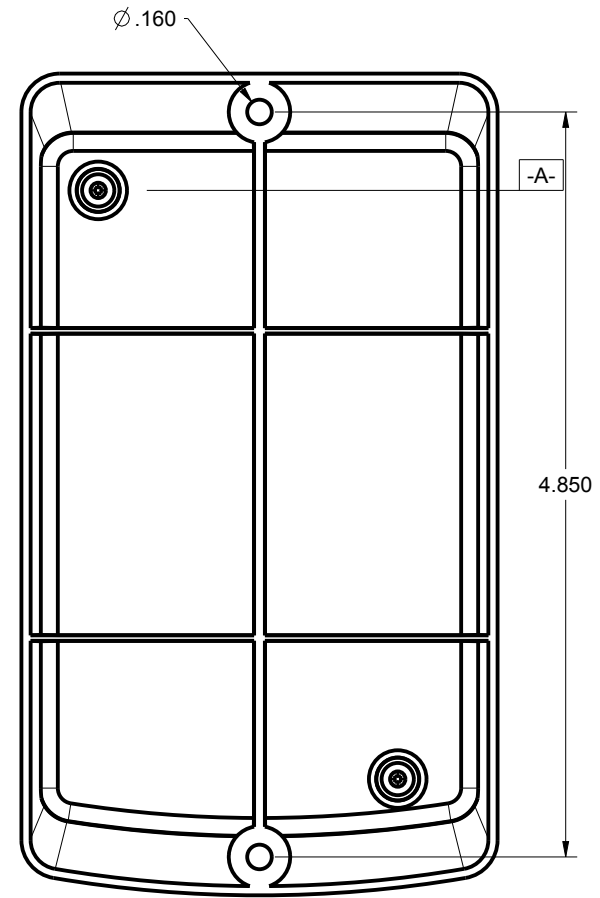
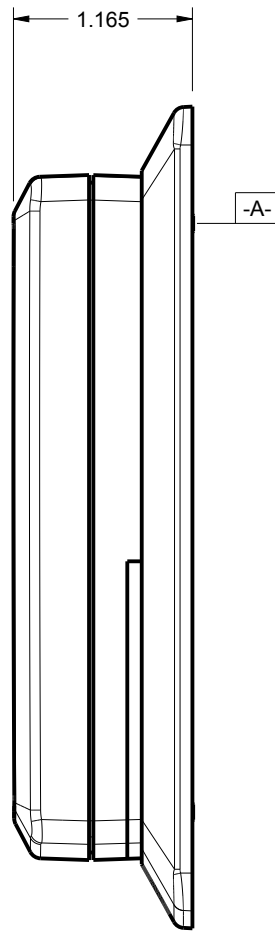
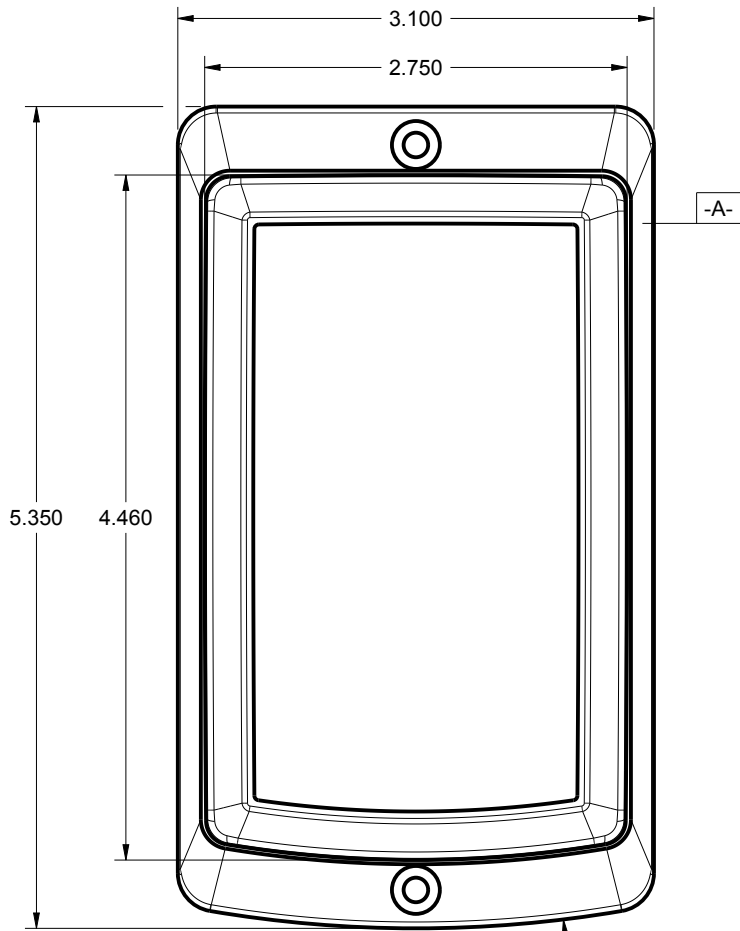

SCALE 0.800

R8.000

TOLERANCES: UNLESS OTHERWISE SPECIFIED  
DIMENSIONS ARE IN U.S. INCHES.  
X.XX = .015 X.XXXX = .001  
X.XXX = .010 X.X° = 1°

**NEW AGE ENCLOSURES**  
2240 South Thornburg Street Santa Maria, CA. 93455  
ph. (805) 595-1310 fax (805) 595-1024

Customer's Part No: 442710X

www.newageenclosures.com

APPROVAL	BY	DATE
CHECK		
ENG.		
SCALE	AS NOTED	

**MED HANDHELD - STANDARD  
SXX-442710X-XXXX**

DRAWN BY  
M BOYER 2009-Jun-27

SIZE A DRAWING NAME  
442710X\_R4\_5

SHEET 2 OF 10 REV.DOC 4.5

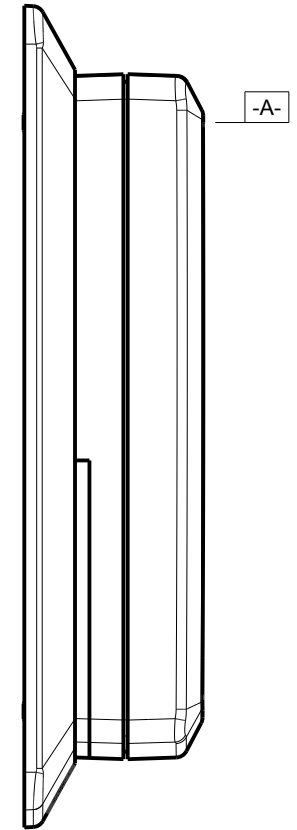
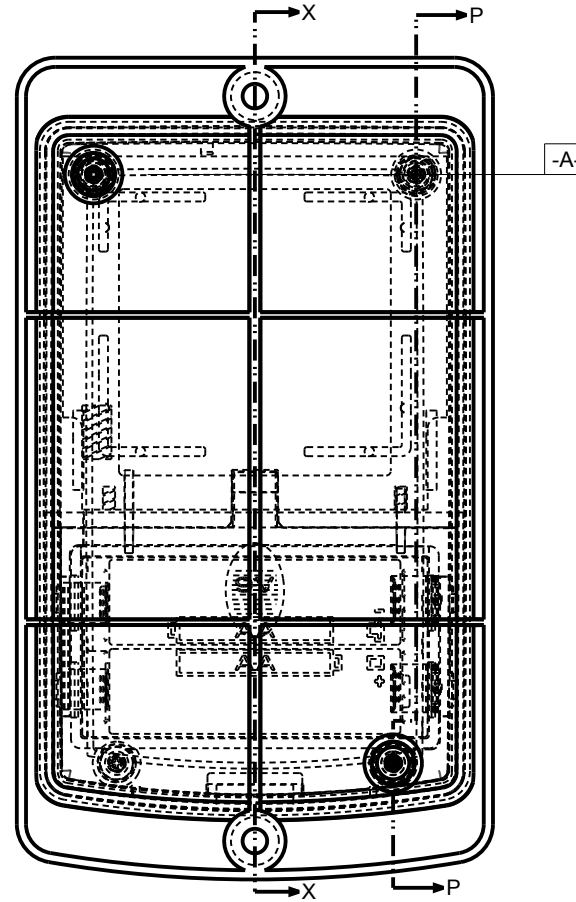
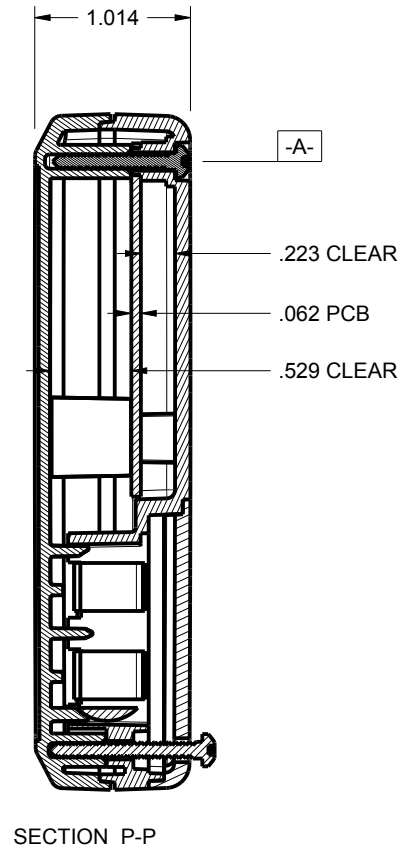
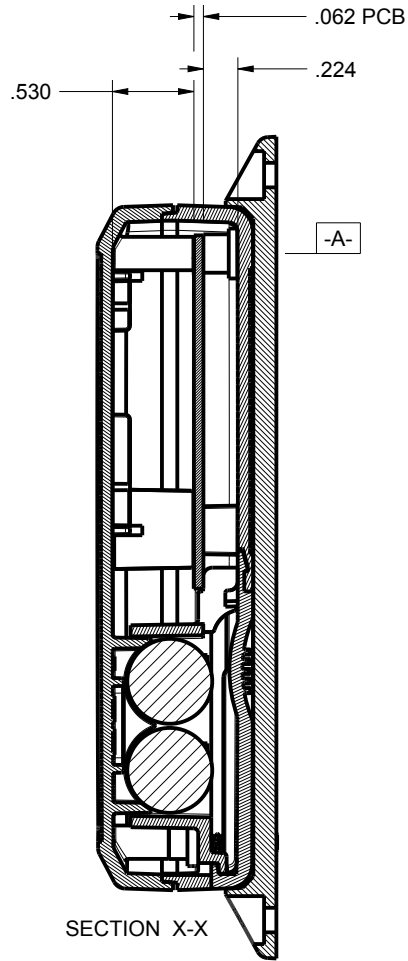

SCALE 0.800

TOLERANCES: UNLESS OTHERWISE SPECIFIED  
DIMENSIONS ARE IN U.S. INCHES.  
X.XX = .015 X.XXXX = .001  
X.XXX = .010 X.X° = 1°

NEW AGE ENCLOSURES

Customer's Part No: 442710X

APPROVAL	BY	DATE
CHECK		
ENG.		
SCALE	AS NOTED	
DRAWN BY	2009-Jun-27	
M BOYER		

**NEW AGE ENCLOSURES**

2240 South Thornburg Street Santa Maria, CA. 93455  
ph. (805) 595-1310 fax (805) 595-1024  
www.newageenclosures.com

**MED HANDHELD - STANDARD  
SXX-442710X-XXXX**

SIZE	DRAWING NAME	SHEET	REV.DOC
A	442710X_R4_5	3 OF 10	4.5

# 442710 COVER

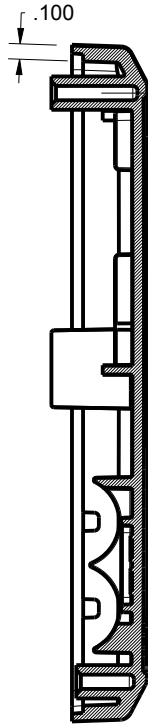

SECTION C-C

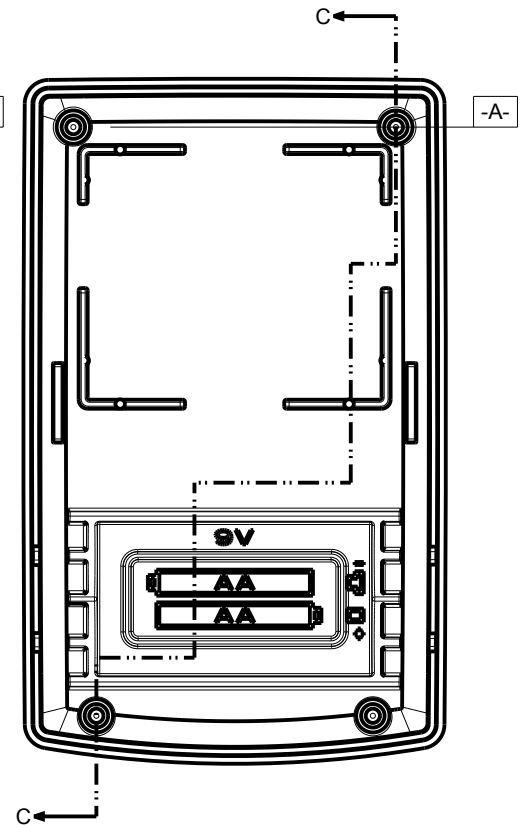
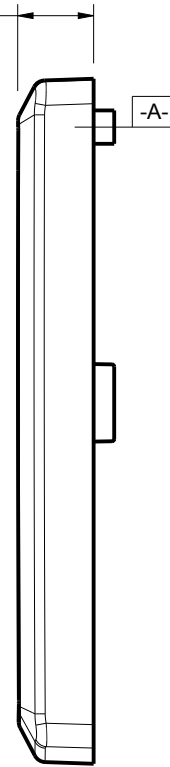
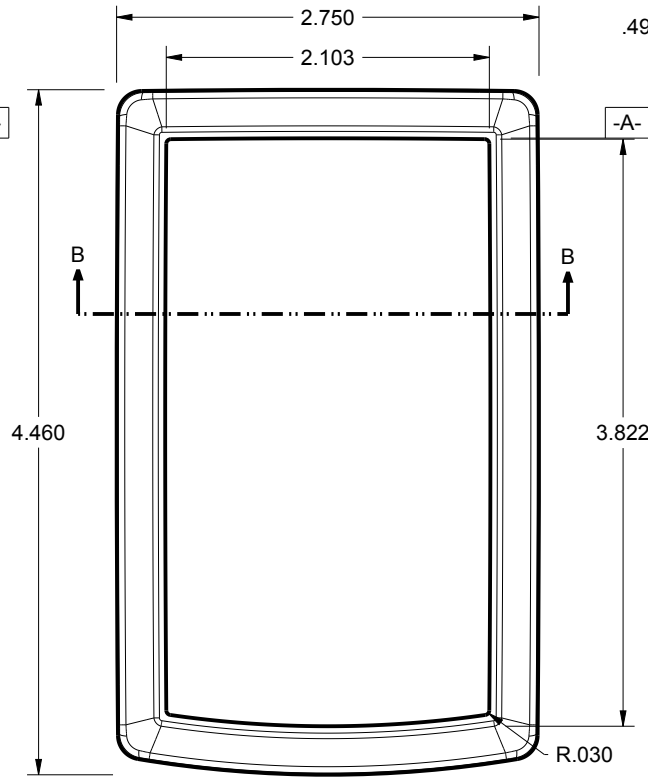
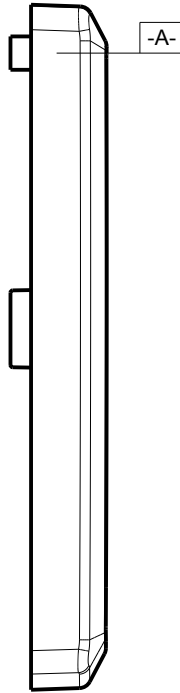

SCALE 0.800

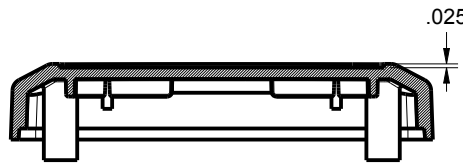

SECTION B-B

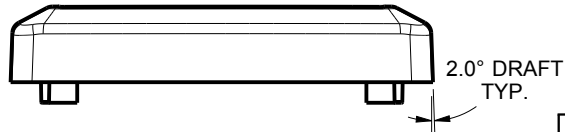

SPECIFIC GEOMETRIC DATA CAN BE OBTAINED FROM THE CAD MODEL AND DOWNLOADED VIA OUR WEBSITE. ALTERNATE FORMS OF CAD INFORMATION ARE AVAILABLE UPON REQUEST.

TOLERANCES: UNLESS OTHERWISE SPECIFIED  
DIMENSIONS ARE IN U.S. INCHES.  
X.XX = .015 X.XXXX = .001  
X.XXX = .010 X.X° = 1°

NEW AGE ENCLOSURES  
Customer's Part No: 442710X

APPROVAL	BY	DATE
CHECK		
ENG.		
SCALE	AS NOTED	

DRAWN BY  
M BOYER  
2009-Jun-27

**NEW AGE ENCLOSURES**  
2240 South Thornburg Street Santa Maria, CA. 93455  
ph. (805) 595-1310 fax (805) 595-1024  
www.newageenclosures.com

**MED HANDHELD - STANDARD  
SXX-442710X-XXXX**

SIZE A	DRAWING NAME 442710X_R4_5	SHEET 4 OF 10	REV.DOC 4.5
-----------	------------------------------	------------------	----------------

442710 BASE

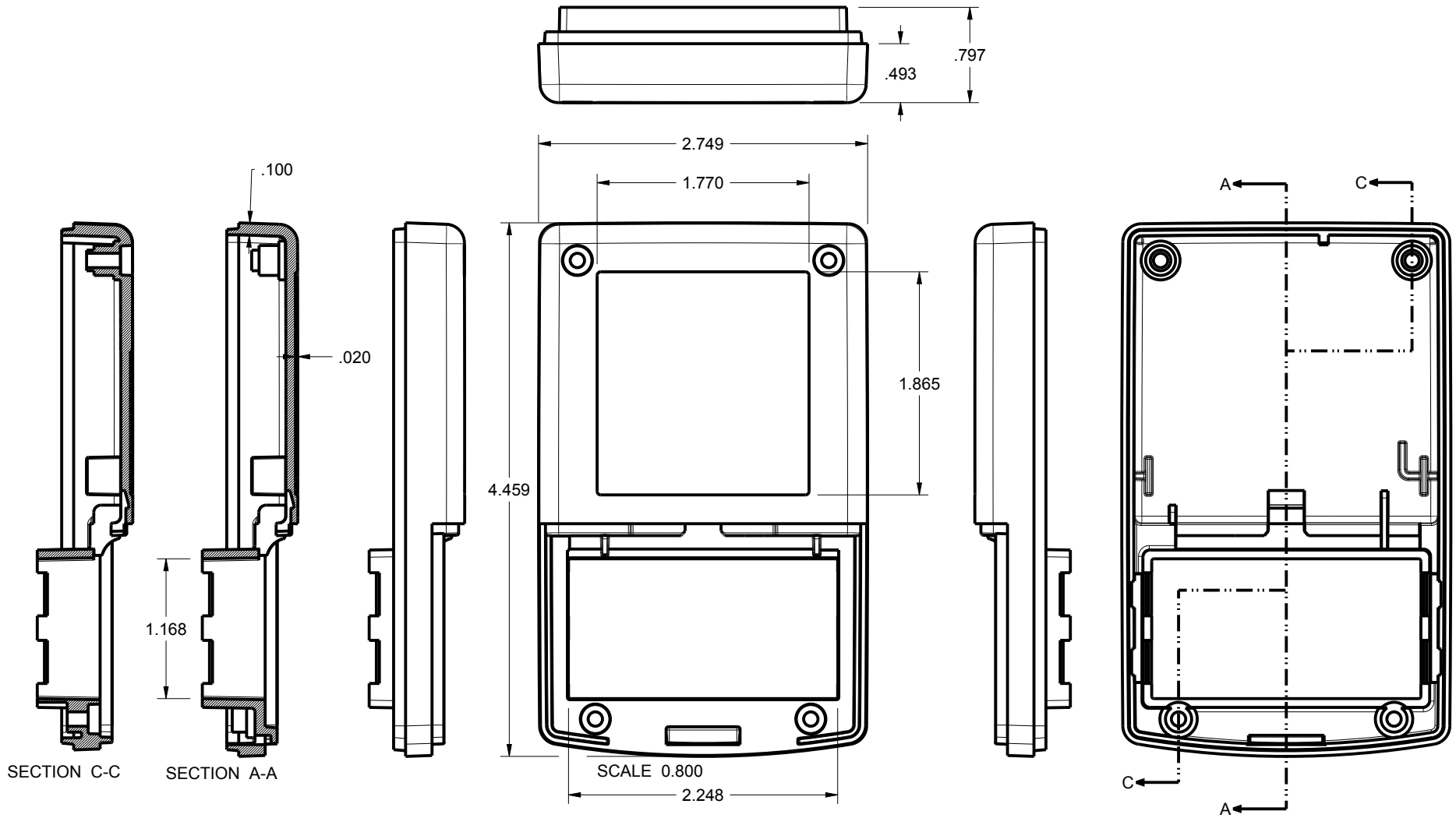

SECTION C-C

SECTION A-A

SCALE 0.800

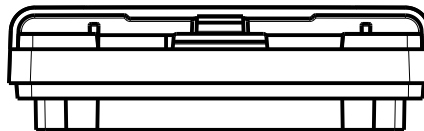

TOLERANCES: UNLESS OTHERWISE SPECIFIED DIMENSIONS ARE IN U.S. INCHES.

X.XX = .015 X.XXXX = .001  
X.XXX = .010 X.X° = 1°

NEW AGE ENCLOSURES

**NEW AGE ENCLOSURES**  
2240 South Thornburg Street Santa Maria, CA. 93455  
ph. (805) 595-1310 fax (805) 595-1024

www.newageenclosures.com

Customer's Part No: 442710X

APPROVAL BY DATE

CHECK

ENG.

SCALE AS NOTED

DRAWN BY M BOYER 2009-Jun-27

**MED HANDHELD - STANDARD  
SXX-442710X-XXXX**

SIZE A DRAWING NAME 442710X\_R4\_5

SHEET 5 OF 10 REV.DOC 4.5

# 442710 HATCH

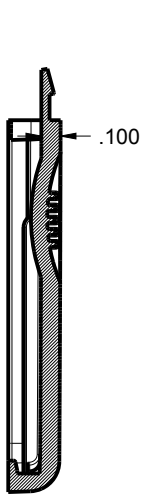
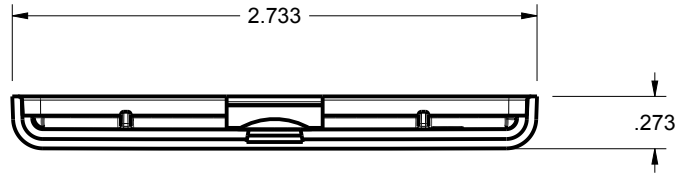

SECTION A-A

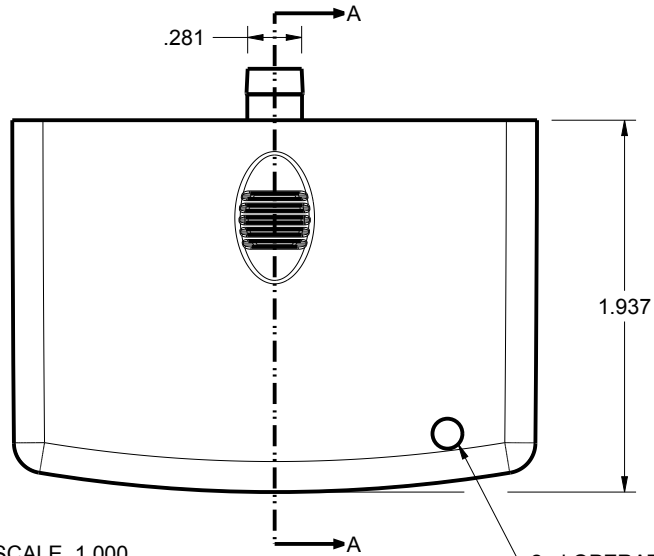

SCALE 1.000

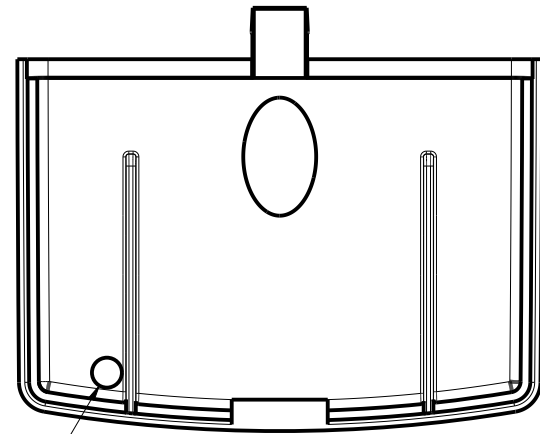
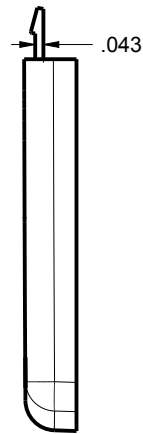

2nd OPERATION:  
CLEARANCE FOR ATTACHMENT  
OF WALL PLATE (S-442710W-K)

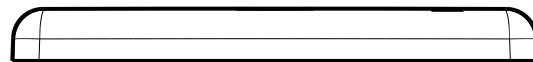

TOLERANCES - UNLESS OTHERWISE SPECIFIED  
DIMENSIONS ARE IN U.S. INCHES.  
X.XX = .015 X.XXXX = .001  
X.XXX = .010 X.X° = 1°

**NEW AGE ENCLOSURES**  
2240 South Thornburg Street Santa Maria, CA. 93455  
ph. (805) 595-1310 fax (805) 595-1024

Customer's Part No: 442710X

www.newageenclosures.com

APPROVAL	BY	DATE
CHECK		
ENG.		
SCALE	AS NOTED	

**MED HANDHELD - STANDARD  
SXX-442710X-XXXX**

DRAWN BY  
M BOYER 2009-Jun-27

SIZE  
A 442710X\_R4\_5

SHEET  
6 OF 10

REV.DOC  
4.5

# 442710 WALL PLATE

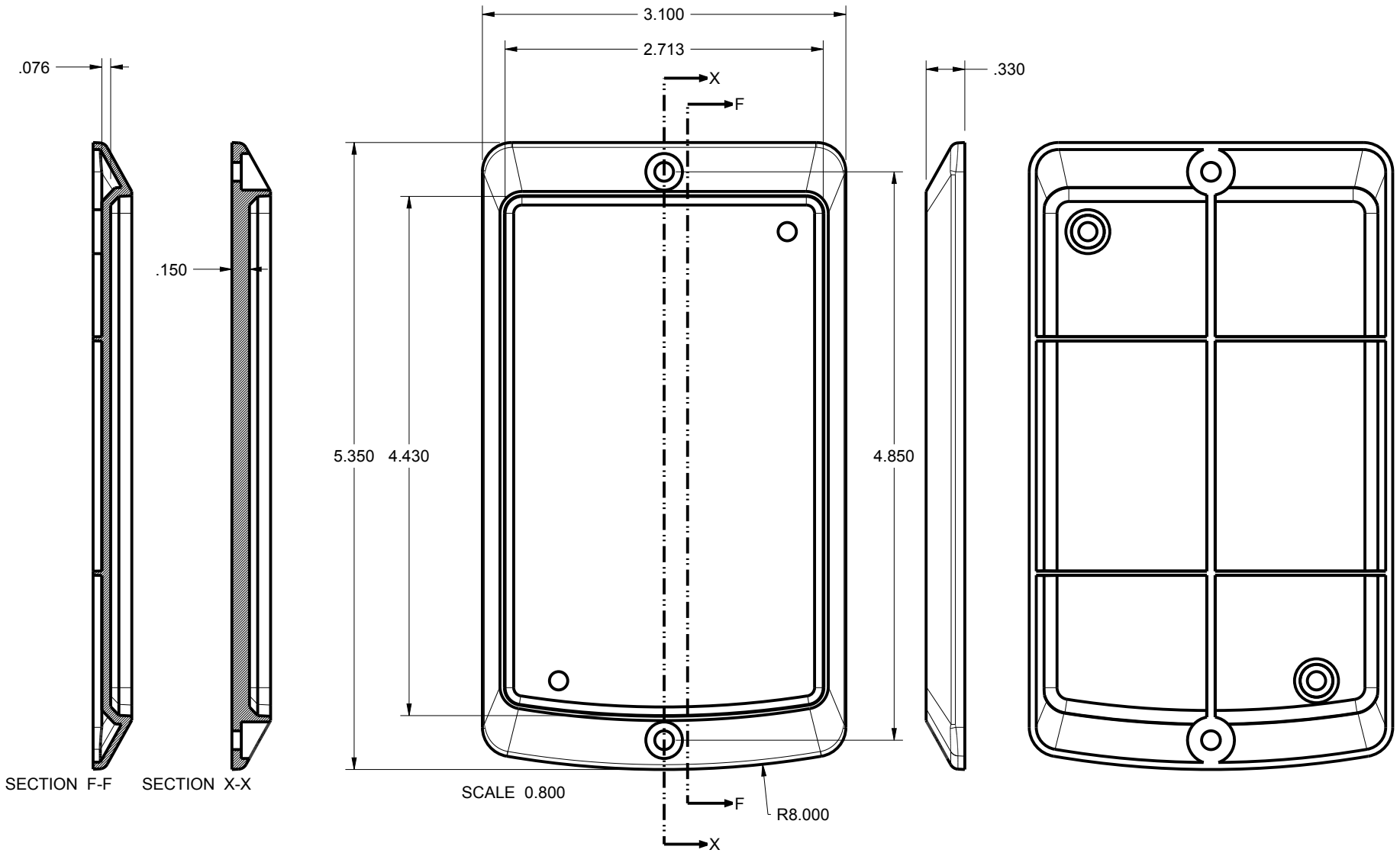

SECTION F-F SECTION X-X

SCALE 0.800

R8.000

TOLERANCES: UNLESS OTHERWISE SPECIFIED  
DIMENSIONS ARE IN U.S. INCHES.  
X.XX = .015 X.XXXX = .001  
X.XXX = .010 X.X° = 1°

NEW AGE ENCLOSURES  
Customer's Part No: 442710X

APPROVAL	BY	DATE
CHECK		
ENG.		
SCALE	AS NOTED	

DRAWN BY  
M BOYER 2009-Jun-27

**NEW AGE ENCLOSURES**  
2240 South Thornburg Street Santa Maria, CA. 93455  
ph. (805) 595-1310 fax (805) 595-1024  
www.newageenclosures.com

MED HANDHELD - STANDARD  
SXX-442710X-XXXX

MED HANDHELD - STANDARD  
SXX-442710X-XXXX

SIZE	DRAWING NAME	SHEET	REV.DOC
A	442710X_R4_5	7 OF 10	4.5

# S442710 PCB - CUSTOMER SUPPLIED

PCB SIZES ARE RECOMMENDATIONS ONLY. FINAL SIZES AND VERIFICATION OF ITS FIT ARE THE SOLE RESPONSIBILITY OF THE OEM.

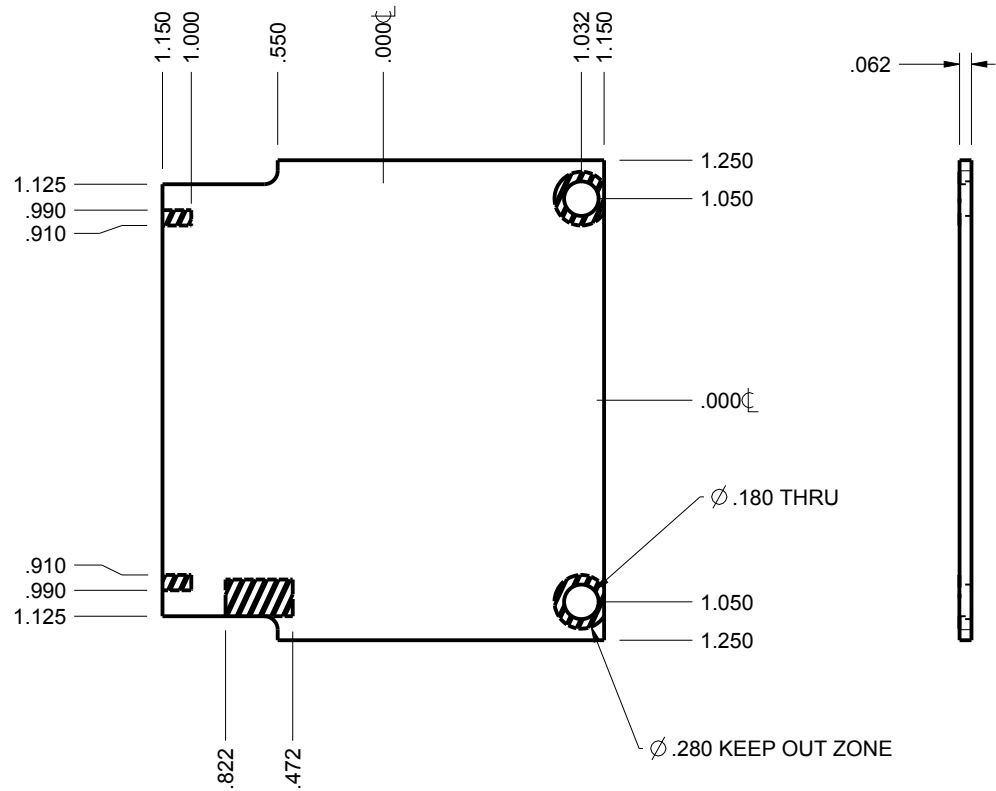

SCALE 1.000

TOLERANCES: UNLESS OTHERWISE SPECIFIED  
DIMENSIONS ARE IN U.S. INCHES.  
X.XX = .015 X.XXXX = .001  
X.XXX = .010 X.X° = 1°

NEW AGE ENCLOSURES

Customer's Part No: 442710X

APPROVAL	BY	DATE
CHECK		
ENG.		
SCALE	AS NOTED	

DRAWN BY	2009-Jun-27
M BOYER	

**NEW AGE ENCLOSURES**

2240 South Thornburg Street Santa Maria, CA. 93455  
ph. (805) 595-1310 fax (805) 595-1024  
www.newageenclosures.com

**MED HANDHELD - STANDARD  
SXX-442710X-XXXX**

SIZE	DRAWING NAME
A	442710X_R4_5

SHEET	REV.DOC
8 OF 10	4.5



**SUGGESTED LABEL SIZE**

(w/ .01" minimum gap per side)  
CUSTOMER SUPPLIED

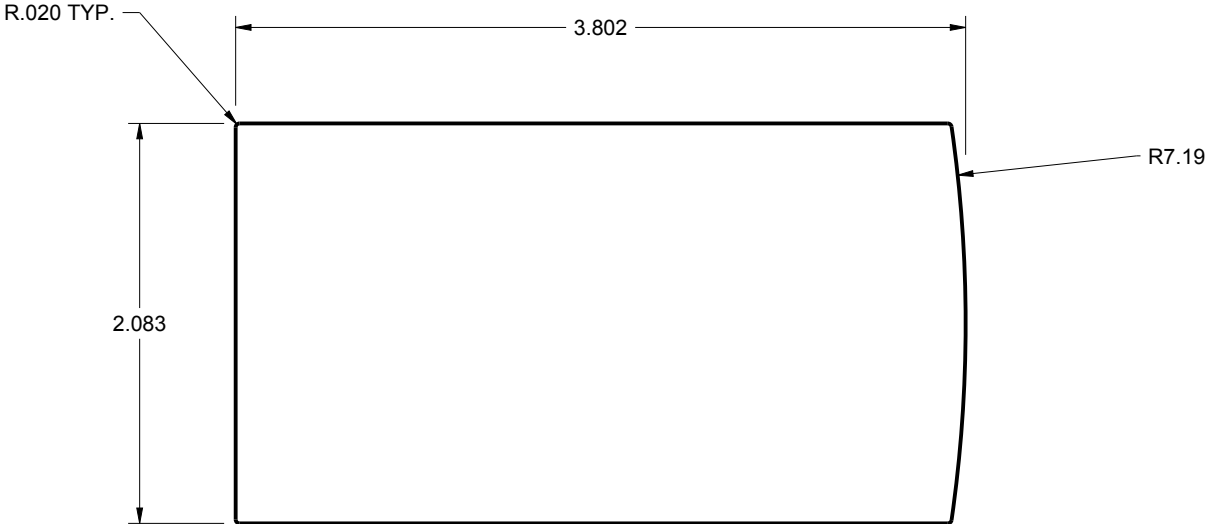

SCALE 1.000

TOLERANCES: UNLESS OTHERWISE SPECIFIED  
DIMENSIONS ARE IN U.S. INCHES.  
X.XX = .015 X.XXXX = .001  
X.XXX = .010 X.X° = 1°

**NEW AGE ENCLOSURES**  
2240 South Thornburg Street Santa Maria, CA. 93455  
ph. (805) 595-1310 fax (805) 595-1024

Customer's Part No: 442710X

[www.newageenclosures.com](http://www.newageenclosures.com)

APPROVAL	BY	DATE
CHECK		
ENG.		
SCALE	AS NOTED	

**MED HANDHELD - STANDARD  
SXX-442710X-XXXX**

DRAWN BY  
M BOYER 2009-Jun-27

SIZE A DRAWING NAME  
442710X\_R4\_5

SHEET 9 OF 10 REV.DOC 4.5

## 2nd OPERATION DETAILS

New Age Enclosures DELIVERS YOUR ENCLOSURE MARKET-READY WITH IN-HOUSE  
CNC MACHINING, PAD PRINTING, ASSEMBLY, AND FULFILLMENT.  
ALL SURFACES AND AREAS ARE AVAILABLE FOR CNC ALTERATION BY New Age Enclosures  
CALL (805) 595-1310 FOR PRICING AND SCHEDULE.  
THE INSIDE RADIUS OF ANY MACHINED FEATURES SHOULD BE NO SMALLER THAN .031"

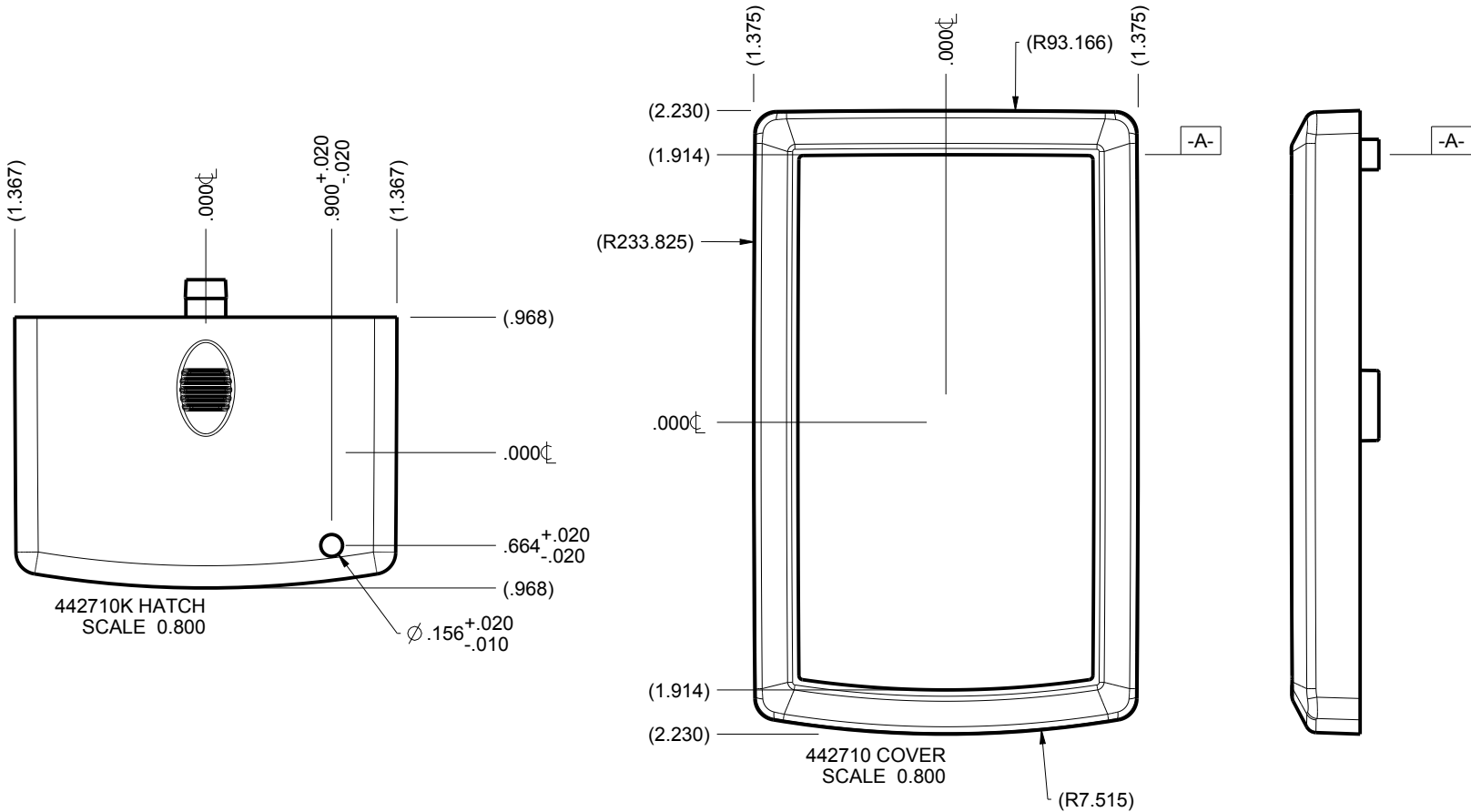

### SXX-442710K-XXX HATCH - ABS, BLACK

STEP NO	DESCRIPTION	CUTTER	FIXTURE	ORIENTATION	PROGRAM
1-H-C1	$\phi .156$ ASSEMBLY HOLE	T2 = .062" EM	113	USE ENCLOSURE ASSEMBLY	o4977

### SXX-442710-XXX COVER - ABS, BLACK

STEP NO	DESCRIPTION	CUTTER	FIXTURE	ORIENTATION	PROGRAM
2-C-C1	-	T2 = .062" EM	333	CENTER BLOCK - RAD. RIGHT	-

### SXX-442710-XXX BASE - ABS, BLACK

STEP NO	DESCRIPTION	CUTTER	FIXTURE	ORIENTATION	PROGRAM
3-B-C1	-	T2 = .062" EM	113	CENTER BLOCK - RAD. RIGHT	-

TOLERANCES: UNLESS OTHERWISE SPECIFIED  
DIMENSIONS ARE IN U.S. INCHES.  
X.XX = .015 X.XXXX = .001  
X.XXX = .010 X.X° = 1°

NEW AGE ENCLOSURES

Customer's Part No: 442710X

APPROVAL BY DATE

CHECK

ENG.

SCALE AS NOTED

DRAWN BY M BOYER 2009-Jun-27

**NEW AGE ENCLOSURES**

2240 South Thornburg Street Santa Maria, CA. 93455  
ph. (805) 595-1310 fax (805) 595-1024  
[www.newageenclosures.com](http://www.newageenclosures.com)

**MED HANDHELD - STANDARD  
SXX-442710X-XXXX**

SIZE A	DRAWING NAME 442710X_R4_5	SHEET 10 OF 10	REV.DOC 4.5
--------	---------------------------	----------------	-------------