HN58C256A Series

HN58C257A Series

256k EEPROM (32-kword \times 8-bit)
Ready/Busy and $\overline{\text{RES}}$ function (HN58C257A)

REJ03C0148-0600Z
Rev. 6.00
Oct. 26. 2006

Description

Renesas Technology's HN58C256A and HN58C257A are electrically erasable and programmable ROMs organized as 32768-word \times 8-bit. They have realized high speed low power consumption and high reliability by employing advanced MNOS memory technology and CMOS process and circuitry technology. They also have a 64-byte page programming function to make their write operations faster.

Features

- Single 5 V supply: 5 V \pm 10%
- Access time: 85 ns/100 ns (max)
- Power dissipation
 - Active: 20 mW/MHz, (typ)
 - Standby: 110 μ W (max)
- On-chip latches: address, data, $\overline{\text{CE}}$, $\overline{\text{OE}}$, $\overline{\text{WE}}$
- Automatic byte write: 10 ms max
- Automatic page write (64 bytes): 10 ms max
- Ready/Busy (only the HN58C257A series)
- $\overline{\text{Data}}$ polling and Toggle bit
- Data protection circuit on power on/off
- Conforms to JEDEC byte-wide standard
- Reliable CMOS with MNOS cell technology
- 10^5 erase/write cycles (in page mode)
- 10 years data retention
- Software data protection
- Write protection by $\overline{\text{RES}}$ pin (only the HN58C257A series)
- Industrial versions (Temperatur range: -20 to 85°C and -40 to 85°C) are also available.
- There are also lead free products.

HN58C256A Series, HN58C257A Series

Ordering Information

Type No.	Access time	Package
HN58C256AP-85	85 ns	600 mil 28-pin plastic DIP
HN58C256AP-10	100 ns	PRDP0028AB-A (DP-28)
HN58C256AFP-85	85 ns	400 mil 28-pin plastic SOP
HN58C256AFP-10	100 ns	PRSP0028DC-A (FP-28D)
HN58C256AT-85	85 ns	28-pin plastic TSOP
HN58C256AT-10	100 ns	PTSA0028ZB-A (TFP-28DB)
HN58C257AT-85	85 ns	32-pin plastic TSOP
HN58C257AT-10	100 ns	PTSA0032KD-A (TFP-32DA)
HN58C256AP-85E	85 ns	600 mil 28-pin plastic DIP
HN58C256AP-10E	100 ns	PRDP0028AB-A (DP-28V) Lead free
HN58C256AFP-85E	85 ns	400 mil 28-pin plastic SOP
HN58C256AFP-10E	100 ns	PRSP0028DC-A (FP-28DV) Lead free
HN58C256AT-85E	85 ns	28-pin plastic TSOP
HN58C256AT-10E	100 ns	PTSA0028ZB-A (TFP-28DBV) Lead free
HN58C257AT-85E	85 ns	32-pin plastic TSOP
HN58C257AT-10E	100 ns	PTSA0032KD-A (TFP-32DAV) Lead free

Pin Arrangement

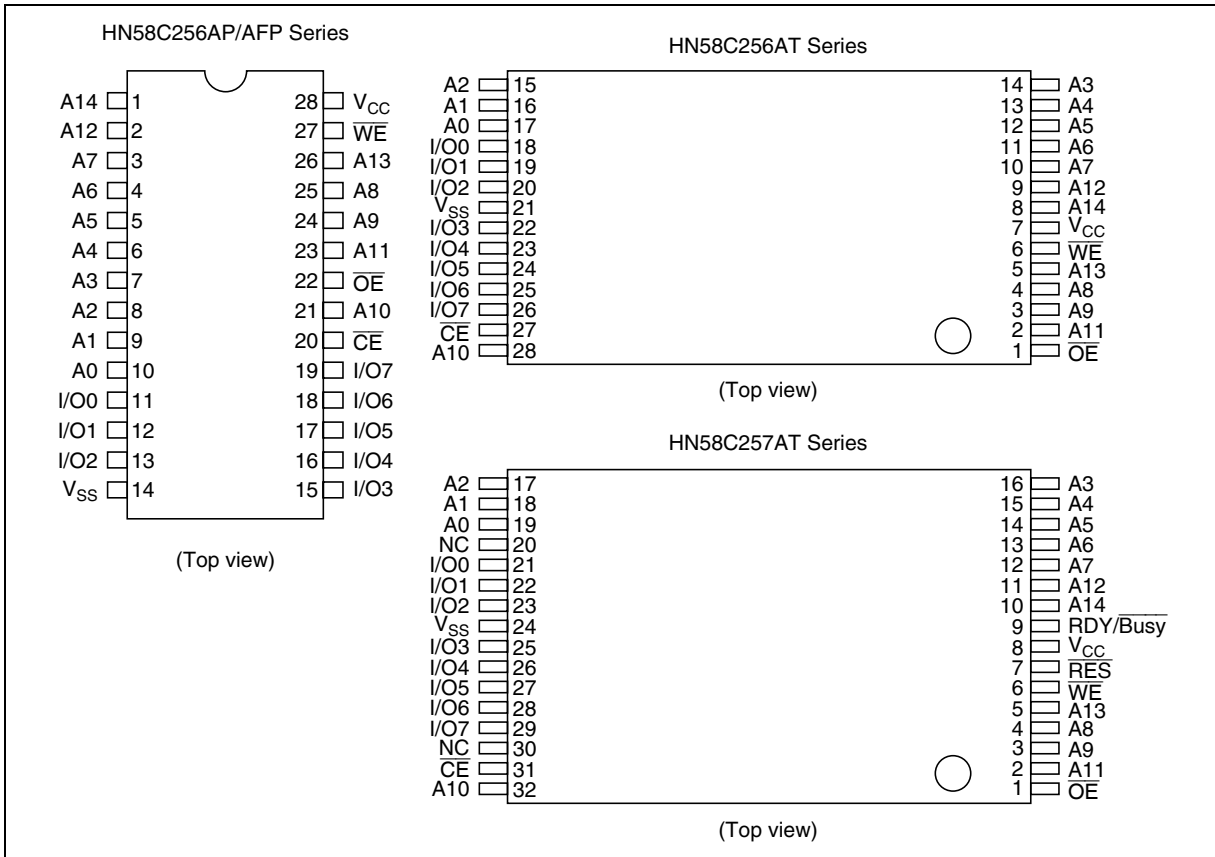

Pin Description

Pin name	Function
A0 to A14	Address input
I/O0 to I/O7	Data input/output
\overline{OE}	Output enable
\overline{CE}	Chip enable
\overline{WE}	Write enable
V_{CC}	Power supply
V_{SS}	Ground
$RDY/Busy^{*1}$	Ready busy
\overline{RES}^{*1}	Reset
NC	No connection

Note: 1. This function is supported by only the HN58C257A series.

Block Diagram

Note: 1. This function is supported by only the HN58C257A series.

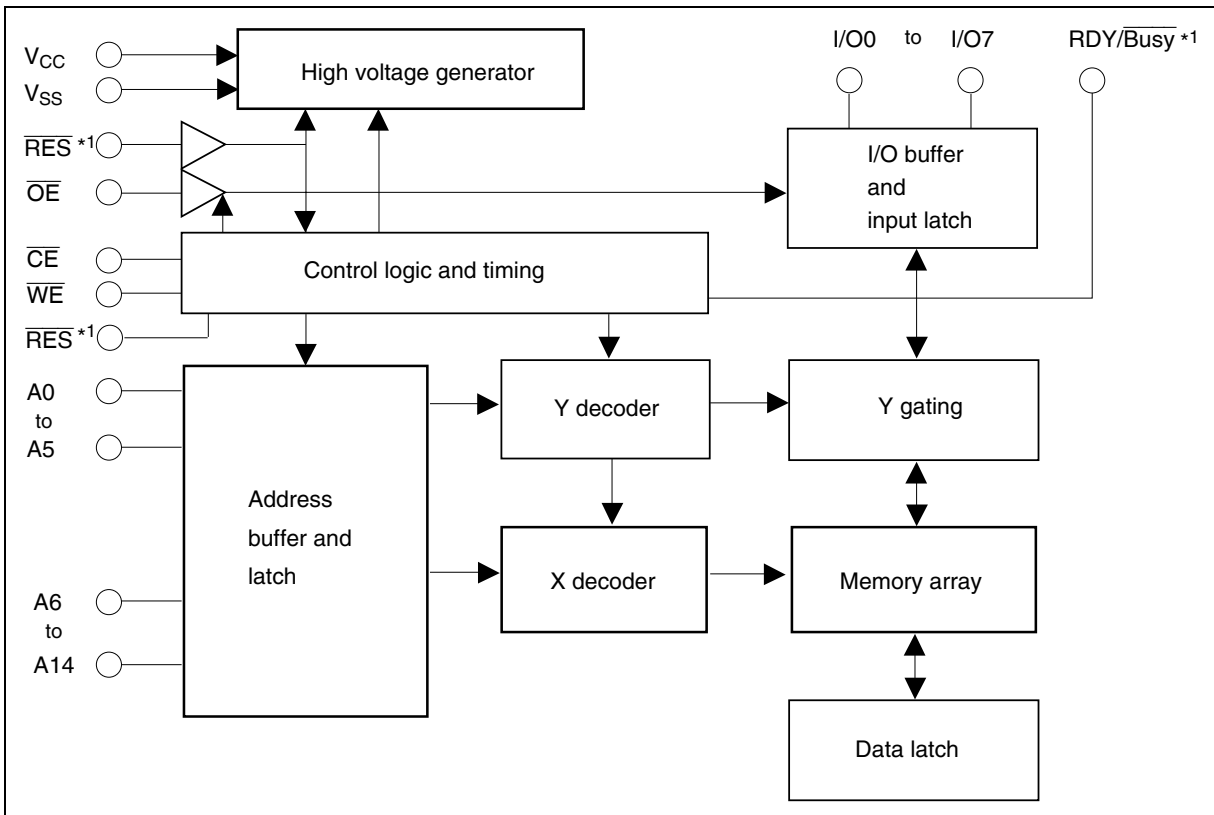

Operation Table

Operation	\overline{CE}	\overline{OE}	\overline{WE}	\overline{RES}^{*3}	$\overline{RDY/Busy}^{*3}$	I/O
Read	V_{IL}	V_{IL}	V_{IH}	V_H^{*1}	High-Z	Dout
Standby	V_{IH}	\times^{*2}	\times	\times	High-Z	High-Z
Write	V_{IL}	V_{IH}	V_{IL}	V_H	High-Z to V_{OL}	Din
Deselect	V_{IL}	V_{IH}	V_{IH}	V_H	High-Z	High-Z
Write inhibit	\times	\times	V_{IH}	\times	—	—
	\times	V_{IL}	\times	\times	—	—
Data polling	V_{IL}	V_{IL}	V_{IH}	V_H	V_{OL}	Dout (I/O7)
Program reset	\times	\times	\times	V_{IL}	High-Z	High-Z

- Notes: 1. Refer to the recommended DC operating condition.
 2. \times : Don't care
 3. This function is supported by only the HN58C257A series.

Absolute Maximum Ratings

Parameter	Symbol	Value	Unit
Power supply voltage relative to V_{SS}	V_{CC}	-0.6 to +7.0	V
Input voltage relative to V_{SS}	V_{in}	-0.5 ^{*1} to +7.0 ^{*3}	V
Operating temperature range ^{*2}	T_{opr}	0 to +70	°C
Storage temperature range	T_{stg}	-55 to +125	°C

- Notes: 1. V_{in} min = -3.0 V for pulse width \leq 50 ns
 2. Including electrical characteristics and data retention
 3. Should not exceed $V_{CC} + 1$ V.

Recommended DC Operating Conditions

Parameter	Symbol	Min	Typ	Max	Unit
Supply voltage	V_{CC}	4.5	5.0	5.5	V
	V_{SS}	0	0	0	V
Input voltage	V_{IL}	-0.3 ^{*1}	—	0.8	V
	V_{IH}	2.2	—	$V_{CC} + 0.3^{*2}$	V
	V_H^{*3}	$V_{CC} - 0.5$	—	$V_{CC} + 1.0$	V
Operating temperature	T_{opr}	0	—	+70	°C

- Notes: 1. V_{IL} min: -1.0 V for pulse width \leq 50 ns.
 2. V_{IH} max: $V_{CC} + 1.0$ V for pulse width \leq 50 ns.
 3. This function is supported by only the HN58C257A series.

HN58C256A Series, HN58C257A Series

DC Characteristics (Ta = 0 to +70°C, V_{CC} = 5.0 V ±10%)

Parameter	Symbol	Min	Typ	Max	Unit	Test conditions
Input leakage current	I _{LI}	—	—	2* ¹	μA	V _{CC} = 5.5 V, Vin = 5.5 V
Output leakage current	I _{LO}	—	—	2	μA	V _{CC} = 5.5 V, Vout = 5.5/0.4 V
Standby V _{CC} current	I _{CC1}	—	—	20	μA	$\overline{CE} = V_{CC}$
	I _{CC2}	—	—	1	mA	$\overline{CE} = V_{IH}$
Operating V _{CC} current	I _{CC3}	—	—	12	mA	Iout = 0 mA, Duty = 100%, Cycle = 1 μs, V _{CC} = 5.5 V
		—	—	30	mA	Iout = 0 mA, Duty = 100%, Cycle = 85 ns, V _{CC} = 5.5 V
Output low voltage	V _{OL}	—	—	0.4	V	I _{OL} = 2.1 mA
Output high voltage	V _{OH}	2.4	—	—	V	I _{OH} = -400 μA

Note: 1. I_{LI} on \overline{RES} = 100 μA max (only the HN58C257A series)

Capacitance (Ta = +25°C, f = 1 MHz)

Parameter	Symbol	Min	Typ	Max	Unit	Test conditions
Input capacitance* ¹	Cin	—	—	6	pF	Vin = 0 V
Output capacitance* ¹	Cout	—	—	12	pF	Vout = 0 V

Note: 1. This parameter is periodically sampled and not 100% tested.

HN58C256A Series, HN58C257A Series

AC Characteristics (Ta = 0 to +70°C, V_{CC} = 5 V±10%)

Test Conditions

- Input pulse levels: 0.4 V to 3.0 V, 0 V to V_{CC} ($\overline{\text{RES}}$ pin*²)
- Input rise and fall time: ≤ 5 ns
- Input timing reference levels: 0.8, 2.0 V
- Output load: 1TTL Gate +100 pF
- Output reference levels: 1.5 V, 1.5 V

Read Cycle

Parameter	Symbol	HN58C256A/HN58C257A				Unit	Test conditions
		-85		-10			
		Min	Max	Min	Max		
Address to output delay	t _{ACC}	—	85	—	100	ns	$\overline{\text{CE}} = \overline{\text{OE}} = V_{\text{IL}}$, $\overline{\text{WE}} = V_{\text{IH}}$
$\overline{\text{CE}}$ to output delay	t _{CE}	—	85	—	100	ns	$\overline{\text{OE}} = V_{\text{IL}}$, $\overline{\text{WE}} = V_{\text{IH}}$
$\overline{\text{OE}}$ to output delay	t _{OE}	10	40	10	50	ns	$\overline{\text{CE}} = V_{\text{IL}}$, $\overline{\text{WE}} = V_{\text{IH}}$
Address to output hold	t _{OH}	0	—	0	—	ns	$\overline{\text{CE}} = \overline{\text{OE}} = V_{\text{IL}}$, $\overline{\text{WE}} = V_{\text{IH}}$
$\overline{\text{OE}}$ ($\overline{\text{CE}}$) high to output float* ¹	t _{DF}	0	40	0	40	ns	$\overline{\text{CE}} = V_{\text{IL}}$, $\overline{\text{WE}} = V_{\text{IH}}$
$\overline{\text{RES}}$ low to output float* ^{1,2}	t _{DFR}	0	350	0	350	ns	$\overline{\text{CE}} = \overline{\text{OE}} = V_{\text{IL}}$, $\overline{\text{WE}} = V_{\text{IH}}$
$\overline{\text{RES}}$ to output delay* ²	t _{RR}	0	450	0	450	ns	$\overline{\text{CE}} = \overline{\text{OE}} = V_{\text{IL}}$, $\overline{\text{WE}} = V_{\text{IH}}$

HN58C256A Series, HN58C257A Series

Write Cycle

Parameter	Symbol	Min* ³	Typ	Max	Unit	Test conditions
Address setup time	t_{AS}	0	—	—	ns	
Address hold time	t_{AH}	50	—	—	ns	
\overline{CE} to write setup time (\overline{WE} controlled)	t_{CS}	0	—	—	ns	
\overline{CE} hold time (\overline{WE} controlled)	t_{CH}	0	—	—	ns	
\overline{WE} to write setup time (\overline{CE} controlled)	t_{WS}	0	—	—	ns	
\overline{WE} hold time (\overline{CE} controlled)	t_{WH}	0	—	—	ns	
\overline{OE} to write setup time	t_{OES}	0	—	—	ns	
\overline{OE} hold time	t_{OEH}	0	—	—	ns	
Data setup time	t_{DS}	50	—	—	ns	
Data hold time	t_{DH}	0	—	—	ns	
\overline{WE} pulse width (\overline{WE} controlled)	t_{WP}	100	—	—	ns	
\overline{CE} pulse width (\overline{CE} controlled)	t_{CW}	100	—	—	ns	
Data latch time	t_{DL}	50	—	—	ns	
Byte load cycle	t_{BLC}	0.2	—	30	μ s	
Byte load window	t_{BL}	100	—	—	μ s	
Write cycle time	t_{WC}	—	—	10* ⁴	ms	
Time to device busy	t_{DB}	120	—	—	ns	
Write start time	t_{DW}	0* ⁵	—	—	ns	
Reset protect time* ²	t_{RP}	100	—	—	μ s	
Reset high time* ^{2,6}	t_{RES}	1	—	—	μ s	

Notes: 1. t_{DF} and t_{DFR} are defined as the time at which the outputs achieve the open circuit conditions and are no longer driven.

2. This function is supported by only the HN58C257A series.
3. Use this device in longer cycle than this value.
4. t_{WC} must be longer than this value unless polling techniques or $\overline{RDY}/\overline{Busy}$ (only the HN58C257A series) are used. This device automatically completes the internal write operation within this value.
5. Next read or write operation can be initiated after t_{DW} if polling techniques or $\overline{RDY}/\overline{Busy}$ (only the HN58C257A series) are used.
6. This parameter is sampled and not 100% tested.
7. A6 through A14 are page address and these addresses are latched at the first falling edge of \overline{WE} .
8. A6 through A14 are page address and these addresses are latched at the first falling edge of \overline{CE} .
9. See AC read characteristics.

Timing Waveforms

Read Timing Waveform

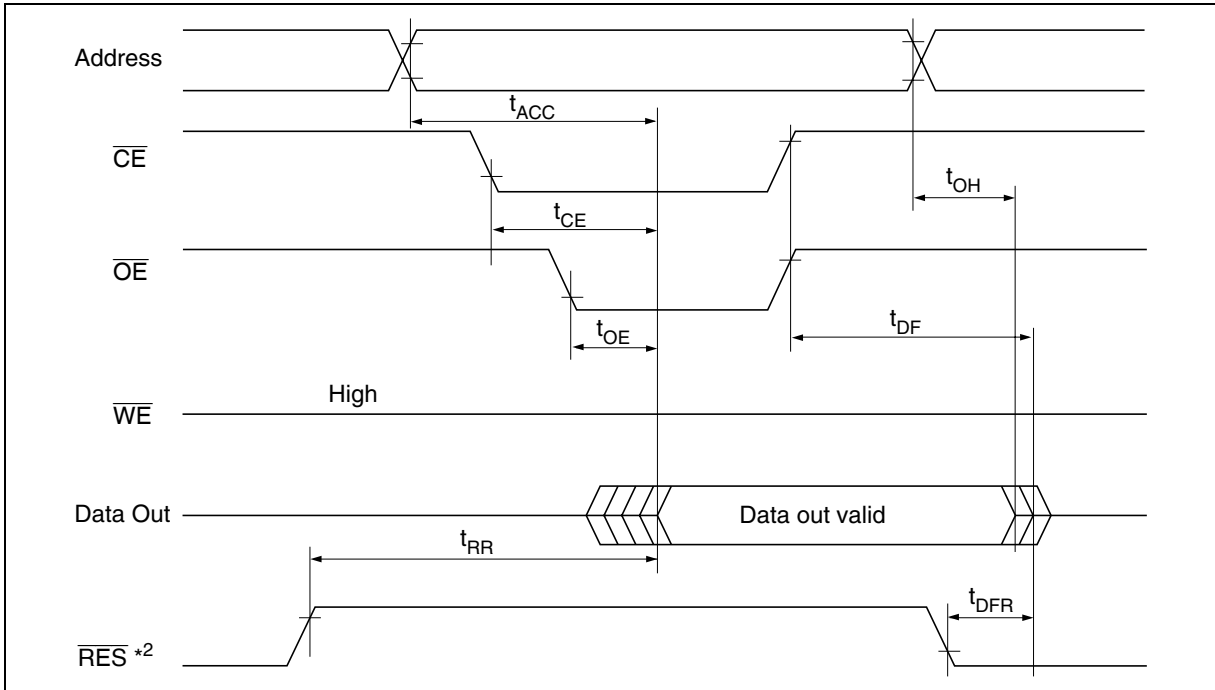

Byte Write Timing Waveform (1) (\overline{WE} Controlled)

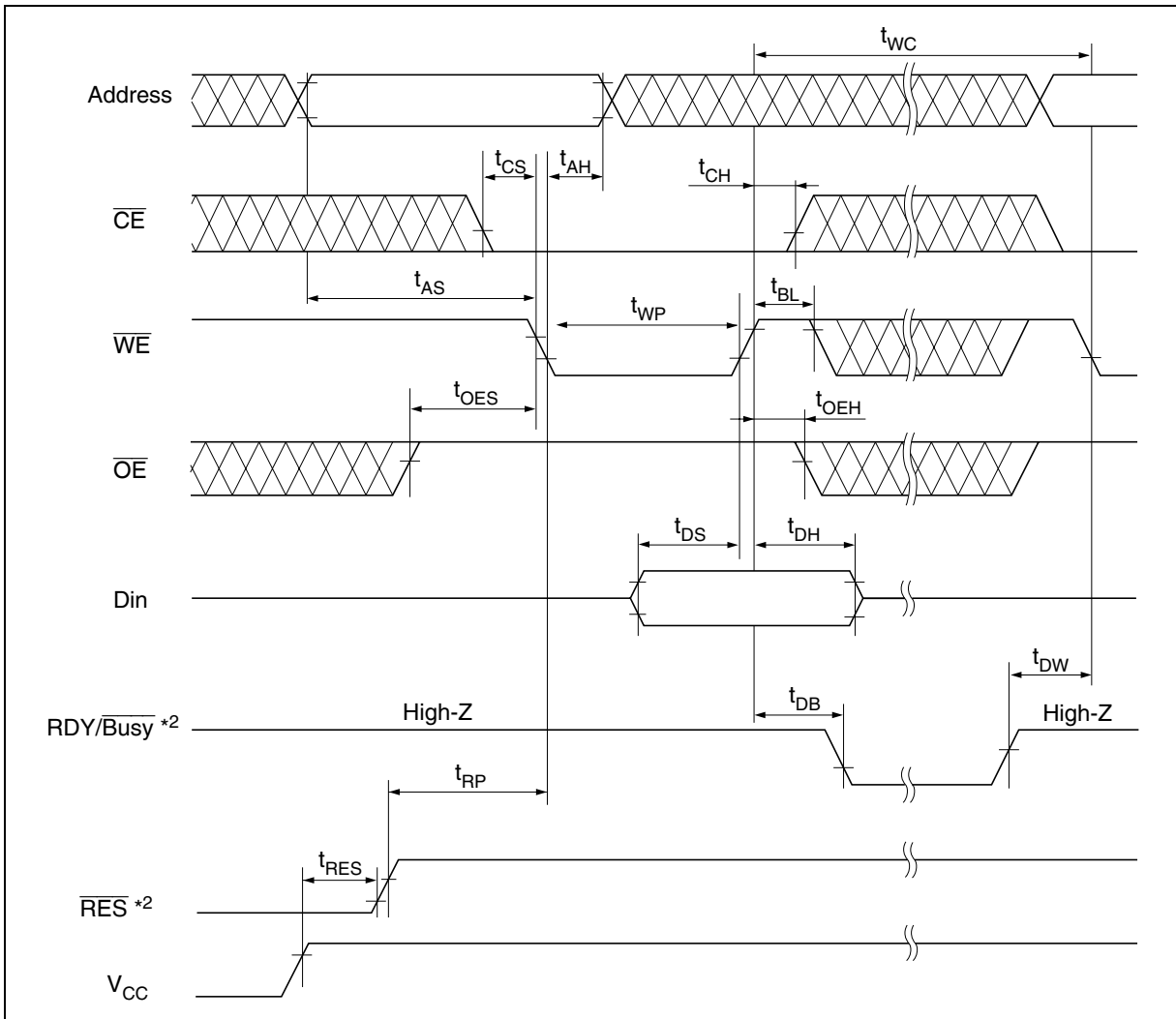

Byte Write Timing Waveform (2) ($\overline{\text{CE}}$ Controlled)

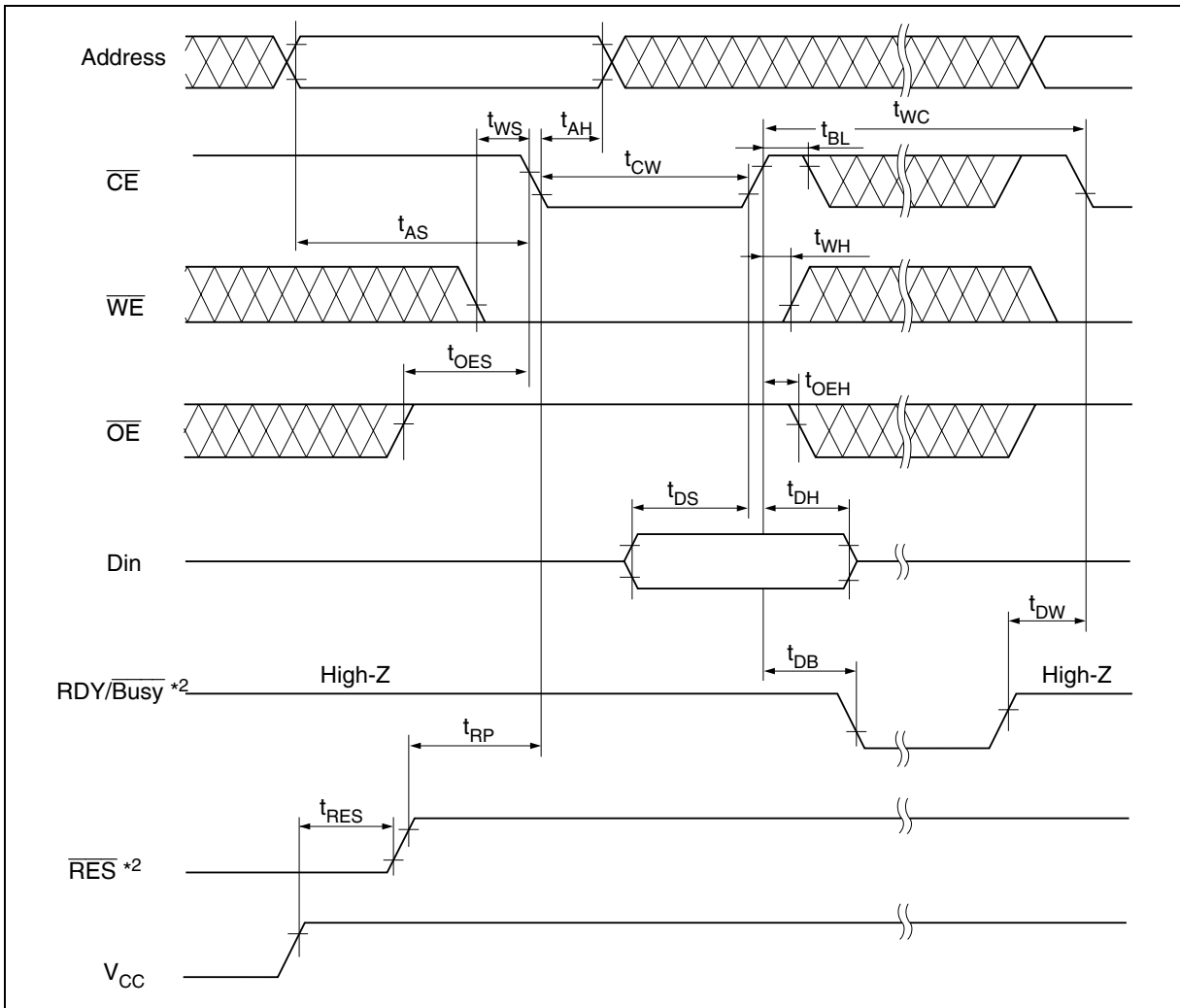

Page Write Timing Waveform (1) ($\overline{\text{WE}}$ Controlled)

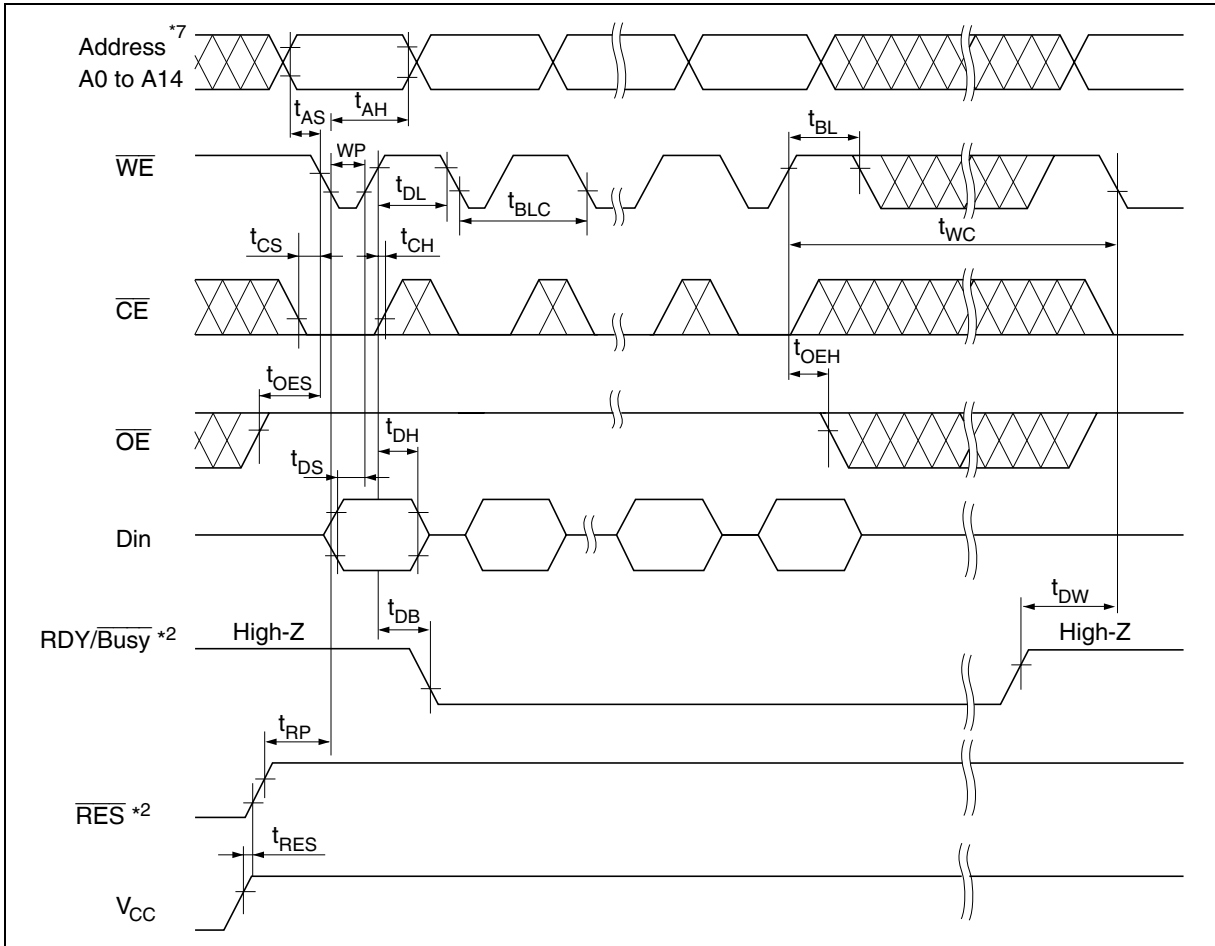

Page Write Timing Waveform (2) (\overline{CE} Controlled)

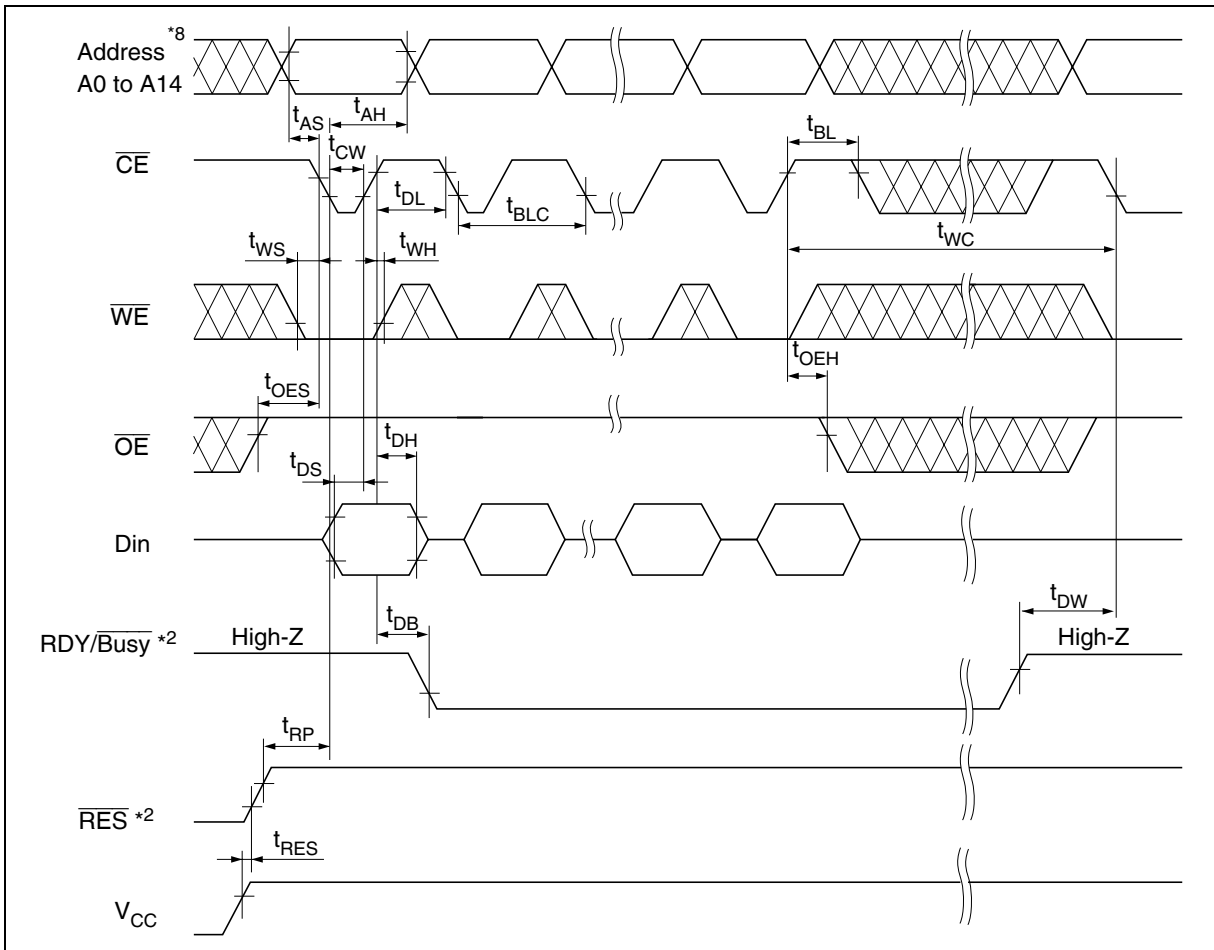

Data Polling Timing Waveform

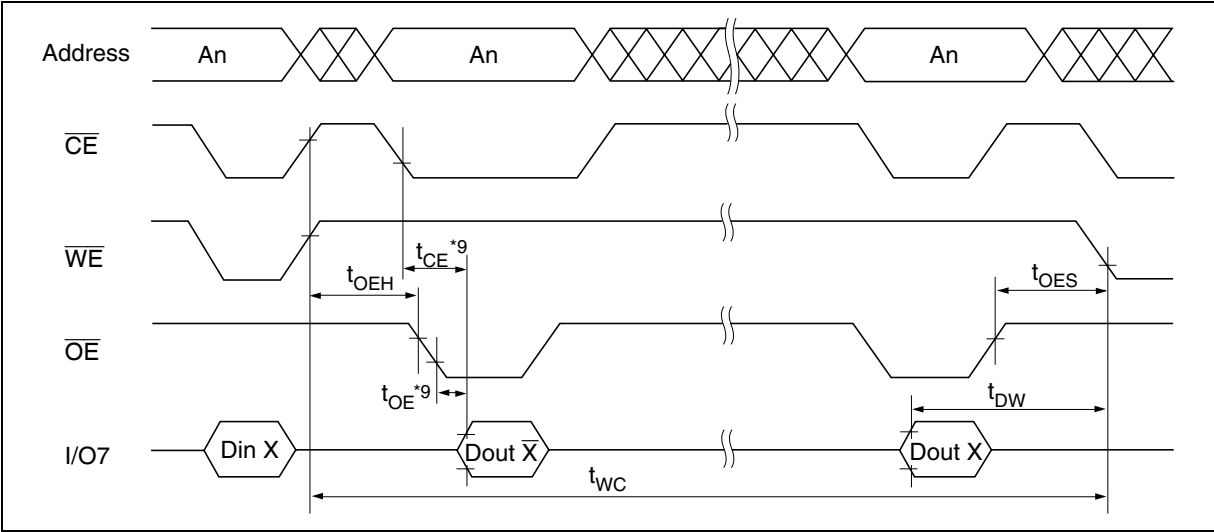

Toggle bit

This device provide another function to determine the internal programming cycle. If the EEPROM is set to read mode during the internal programming cycle, I/O6 will charge from “1” to “0” (toggling) for each read. When the internal programming cycle is finished, toggling of I/O6 will stop and the device can be accessible for next read or program.

Toggle bit Waveform

- Notes: 1. I/O6 beginning state is "1".
 2. I/O6 ending state will vary.
 3. See AC read characteristics.
 4. Any address location can be used, but the address must be fixed.

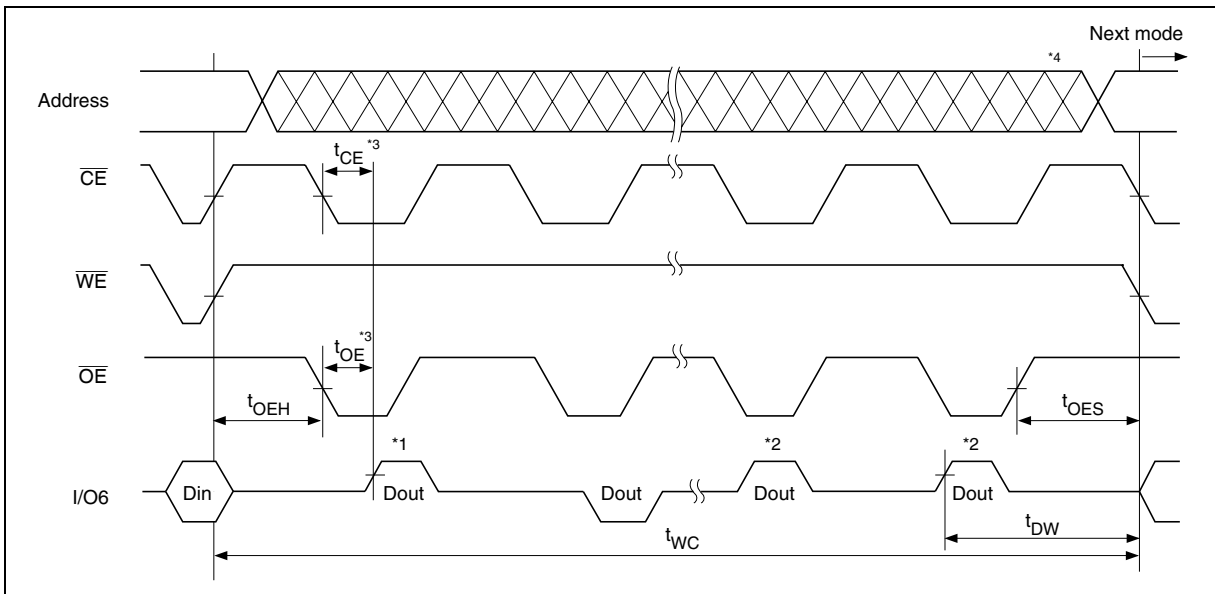

Software Data Protection Timing Waveform (1) (in protection mode)

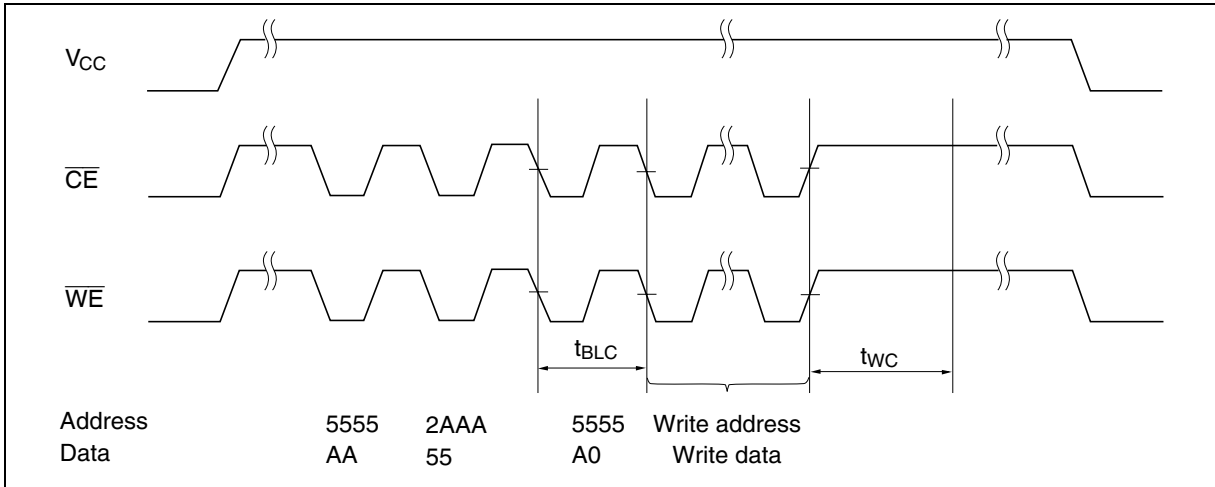

Software Data Protection Timing Waveform (2) (in non-protection mode)

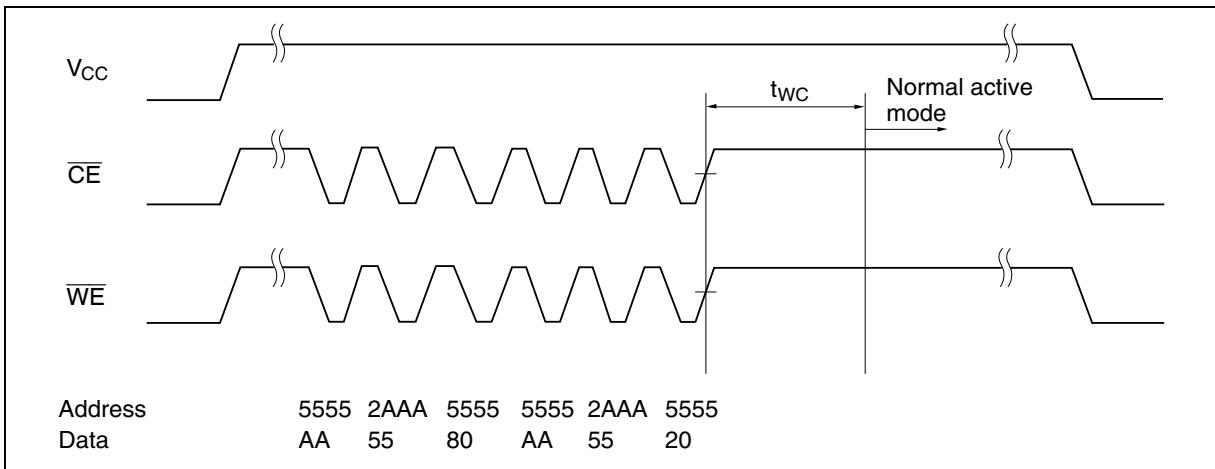

Functional Description

Automatic Page Write

Page-mode write feature allows 1 to 64 bytes of data to be written into the EEPROM in a single write cycle. Following the initial byte cycle, an additional 1 to 63 bytes can be written in the same manner. Each additional byte load cycle must be started within 30 μ s from the preceding falling edge of \overline{WE} or \overline{CE} . When \overline{CE} or \overline{WE} is high for 100 μ s after data input, the EEPROM enters write mode automatically and the input data are written into the EEPROM.

\overline{Data} Polling

\overline{Data} polling indicates the status that the EEPROM is in a write cycle or not. If EEPROM is set to read mode during a write cycle, an inversion of the last byte of data outputs from I/O7 to indicate that the EEPROM is performing a write operation.

$\overline{RDY/Busy}$ Signal (only the HN58C257A series)

$\overline{RDY/Busy}$ signal also allows status of the EEPROM to be determined. The $\overline{RDY/Busy}$ signal has high impedance except in write cycle and is lowered to V_{OL} after the first write signal. At the end of a write cycle, the $\overline{RDY/Busy}$ signal changes state to high impedance.

\overline{RES} Signal (only the HN58C257A series)

When \overline{RES} is low, the EEPROM cannot be read or programmed. Therefore, data can be protected by keeping \overline{RES} low when V_{CC} is switched. \overline{RES} should be high during read and programming because it doesn't provide a latch function.

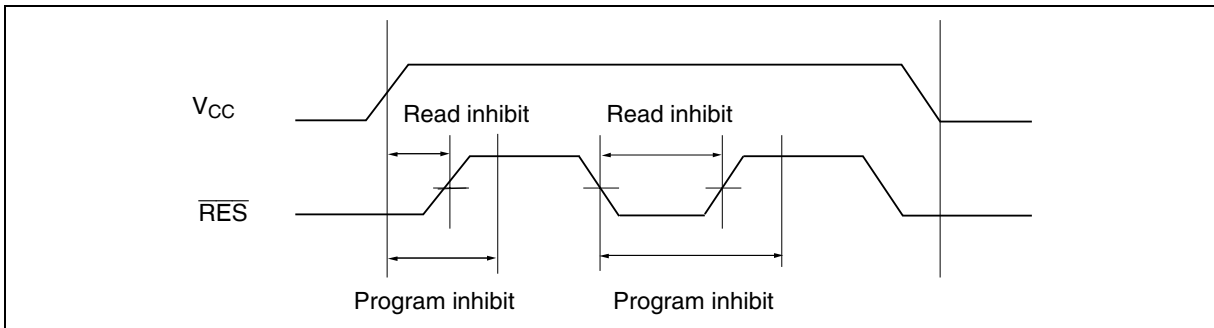

\overline{WE} , \overline{CE} Pin Operation

During a write cycle, addresses are latched by the falling edge of \overline{WE} or \overline{CE} , and data is latched by the rising edge of \overline{WE} or \overline{CE} .

Write/Erase Endurance and Data Retention Time

The endurance is 10^5 cycles in case of the page programming and 10^4 cycles in case of the byte programming (1% cumulative failure rate). The data retention time is more than 10 years when a device is page-programmed less than 10^4 cycles.

Data Protection

To prevent this phenomenon, this device has a noise cancelation function that cuts noise if its width is 20 ns or less.

1. Data Protection against Noise on Control Pins (\overline{CE} , \overline{OE} , \overline{WE}) during Operation

During readout or standby, noise on the control pins may act as a trigger and turn the EEPROM to programming mode by mistake. Be careful not to allow noise of a width of more than 20 ns on the control pins.

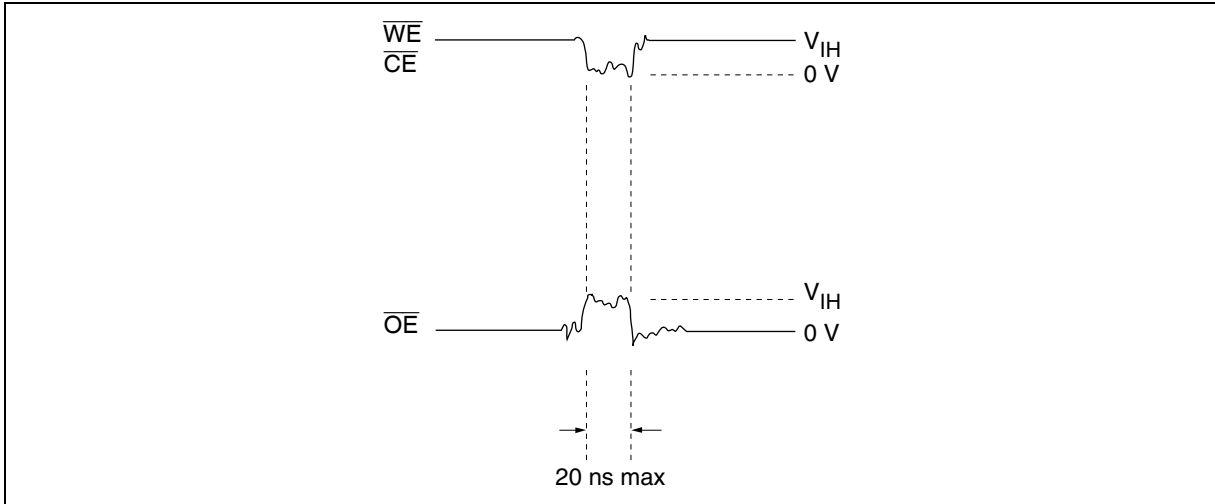

HN58C256A Series, HN58C257A Series

2. Data Protection at V_{CC} On/Off

When V_{CC} is turned on or off, noise on the control pins generated by external circuits (CPU, etc) may act as a trigger and turn the EEPROM to program mode by mistake. To prevent this unintentional programming, the EEPROM must be kept in an unprogrammable state while the CPU is in an unstable state.

Note: The EEPROM should be kept in unprogrammable state during V_{CC} on/off by using CPU RESET signal.

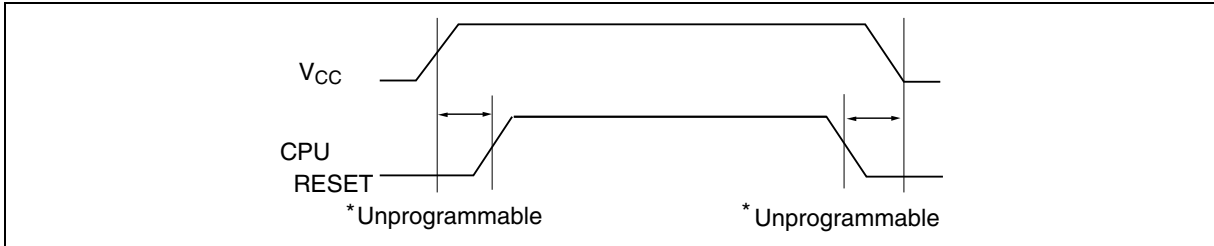

2.1 Protection by \overline{CE} , \overline{OE} , \overline{WE}

To realize the unprogrammable state, the input level of control pins must be held as shown in the table below.

\overline{CE}	V_{CC}	×	×
\overline{OE}	×	V_{SS}	×
\overline{WE}	×	×	V_{CC}

×: Don't care.

V_{CC} : Pull-up to V_{CC} level.

V_{SS} : Pull-down to V_{SS} level.

2.2 Protection by \overline{RES} (only the HN58C257A series)

The unprogrammable state can be realized by that the CPU's reset signal inputs directly to the EEPROM's \overline{RES} pin. \overline{RES} should be kept V_{SS} level during V_{CC} on/off.

The EEPROM breaks off programming operation when \overline{RES} becomes low, programming operation doesn't finish correctly in case that \overline{RES} falls low during programming operation. \overline{RES} should be kept high for 10 ms after the last data input.

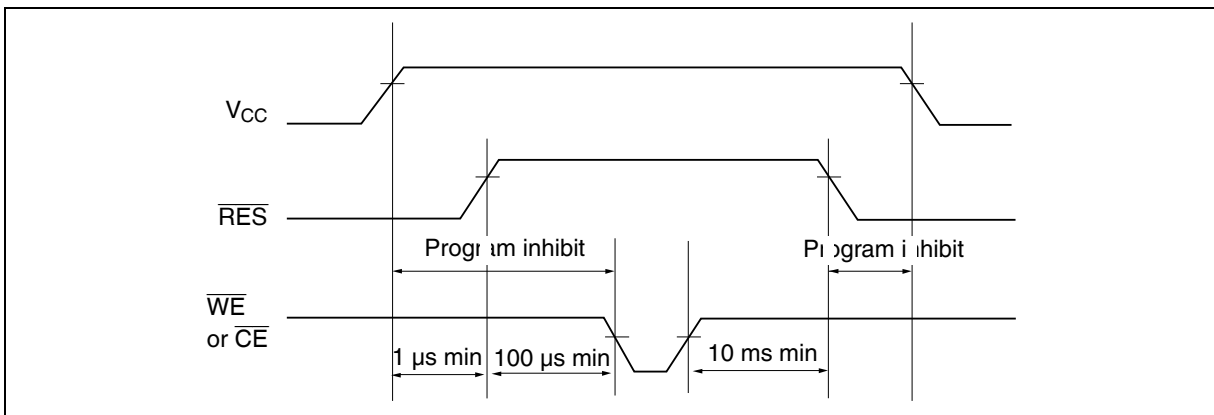

HN58C256A Series, HN58C257A Series

3. Software data protection

To prevent unintentional programming, this device has the software data protection (SDP) mode. The SDP is enabled by inputting the following 3 bytes code and write data. SDP is not enabled if only the 3 bytes code is input. To program data in the SDP enable mode, 3 bytes code must be input before write data.

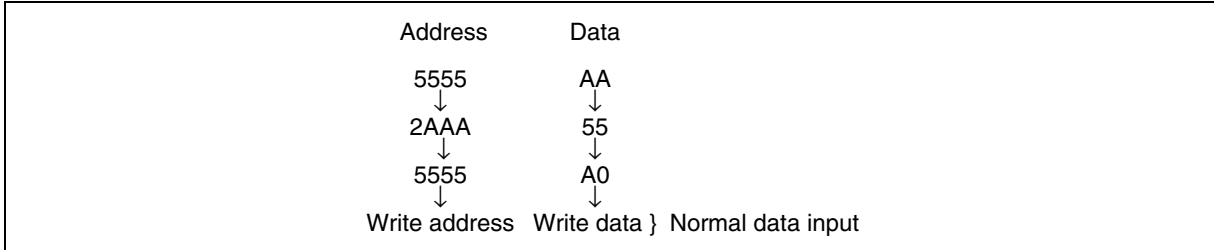

The SDP mode is disabled by inputting the following 6 bytes code. Note that, if data is input in the SDP disable cycle, data can not be written.

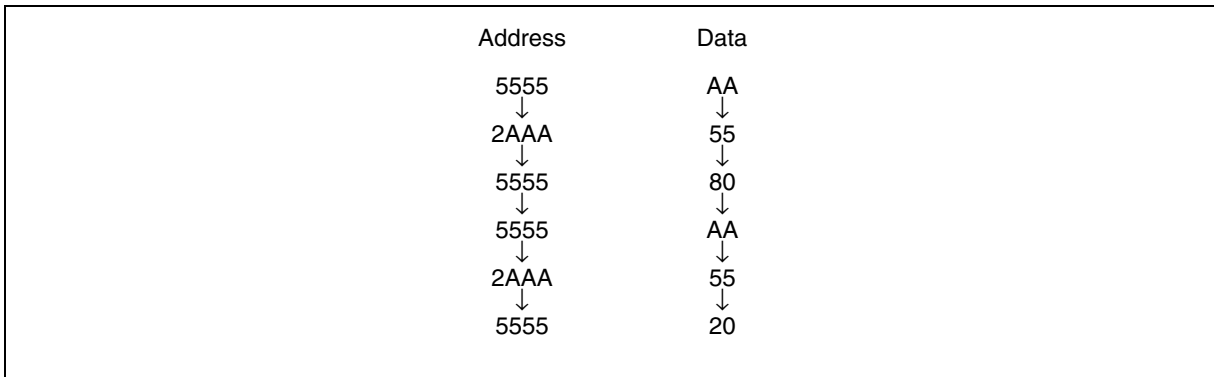

The software data protection is not enabled at the shipment.

Note: There are some differences between Renesas Technology's and other company's for enable/disable sequence of software data protection. If there are any questions, please contact with Renesas Technology's sales offices.

HN58C256A Series, HN58C257A Series

Package Dimensions

HN58C256AP Series (PRDP0028AB-A / Previous Code: DP-28, DP-28V)

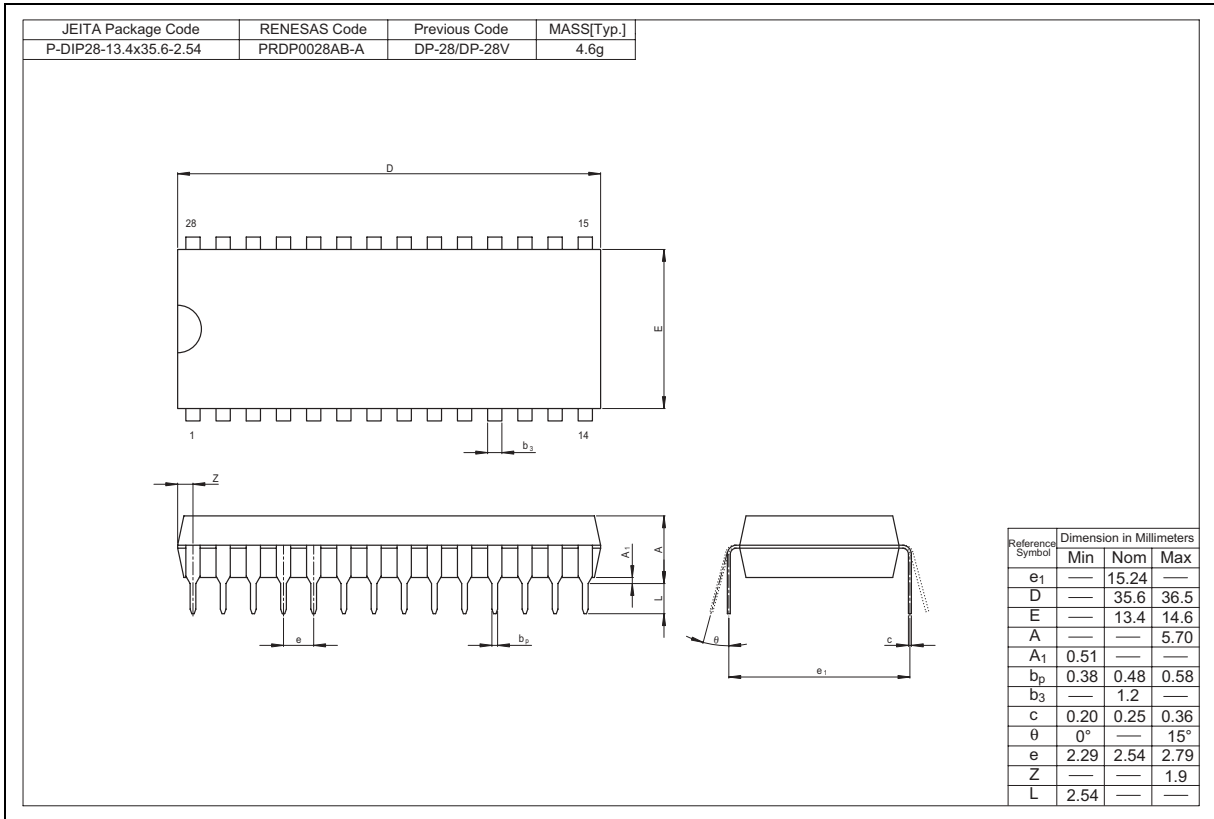

HN58C256A Series, HN58C257A Series

Package Dimensions (cont.)

HN58C256AFP Series (PRSP0028DC-A / Previous Code: FP-28D, FP-28DV)

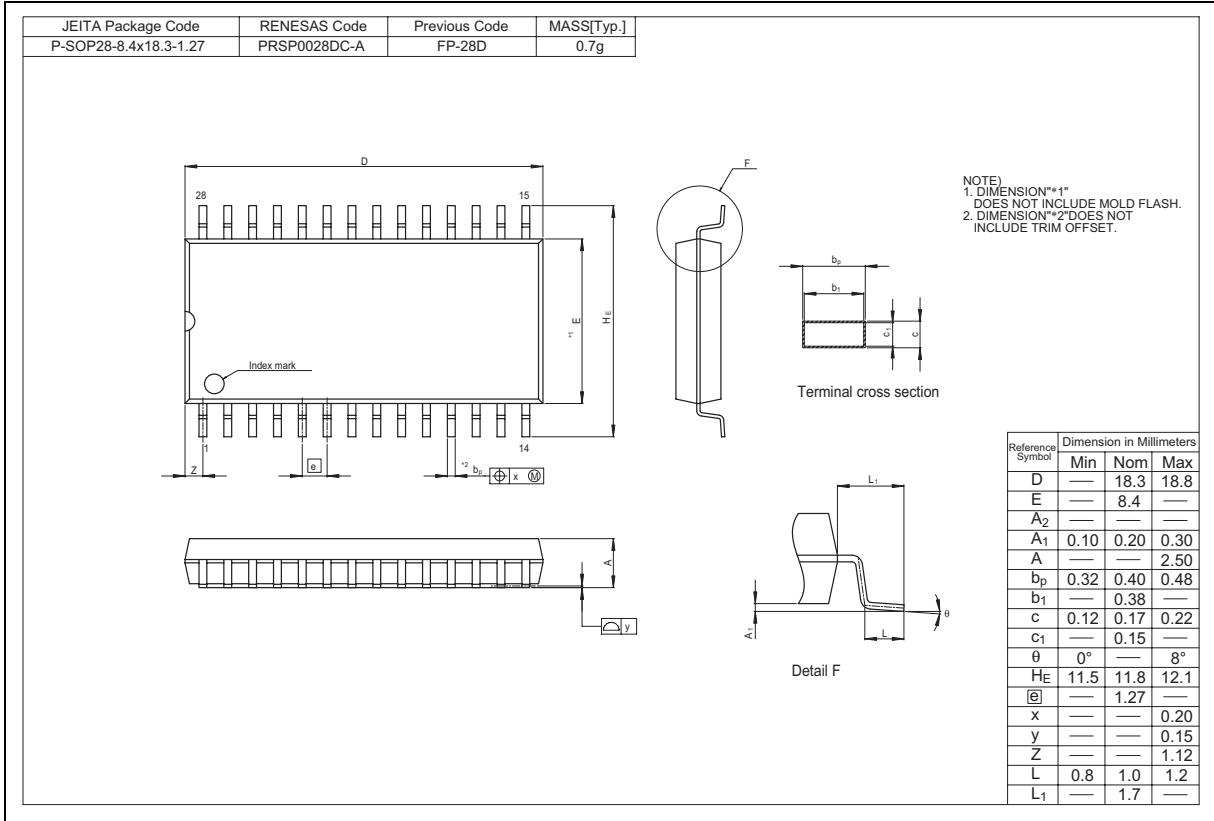

HN58C256A Series, HN58C257A Series

Package Dimensions (cont.)

HN58C256AT Series (PTSA0028ZB-A / Previous Code: TFP-28DB, TFP-28DBV)

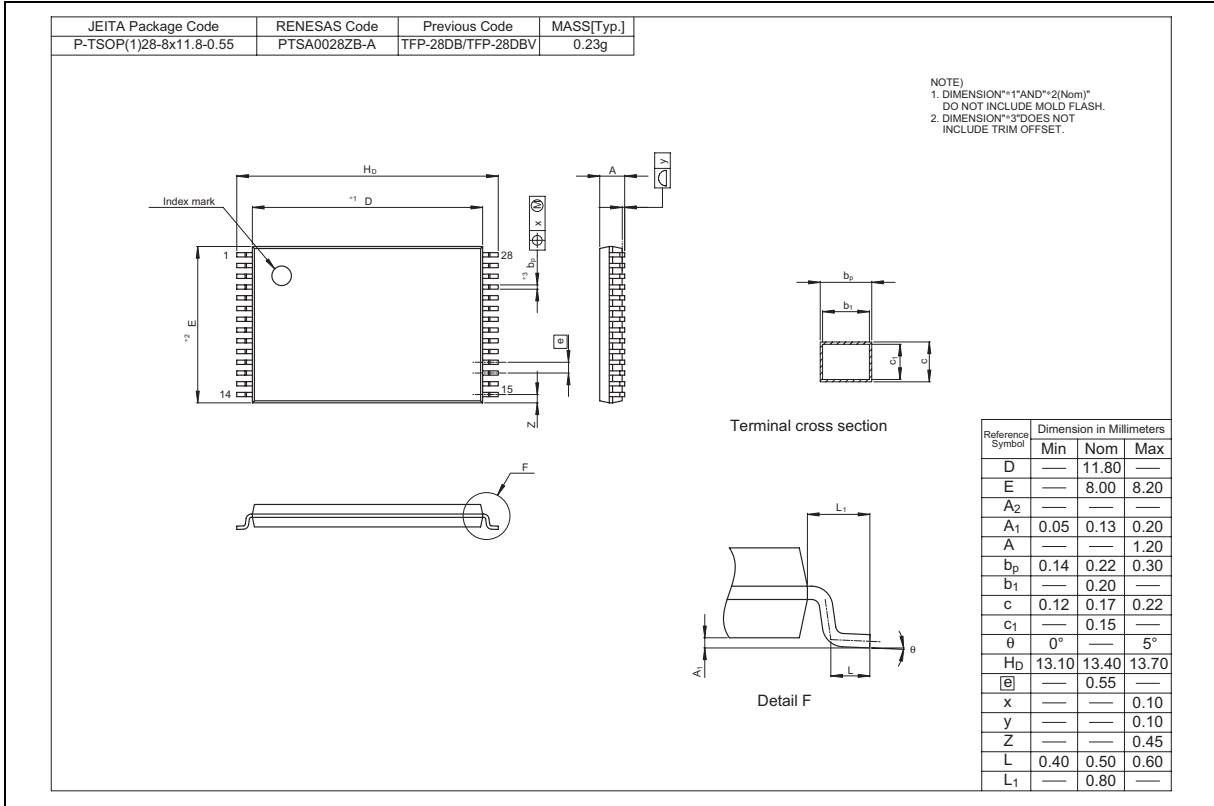

HN58C256A Series, HN58C257A Series

Package Dimensions (cont.)

HN58C257AT Series (PTSA0032KD-A / Previous Code: TFP-32DA, TFP-32DAV)

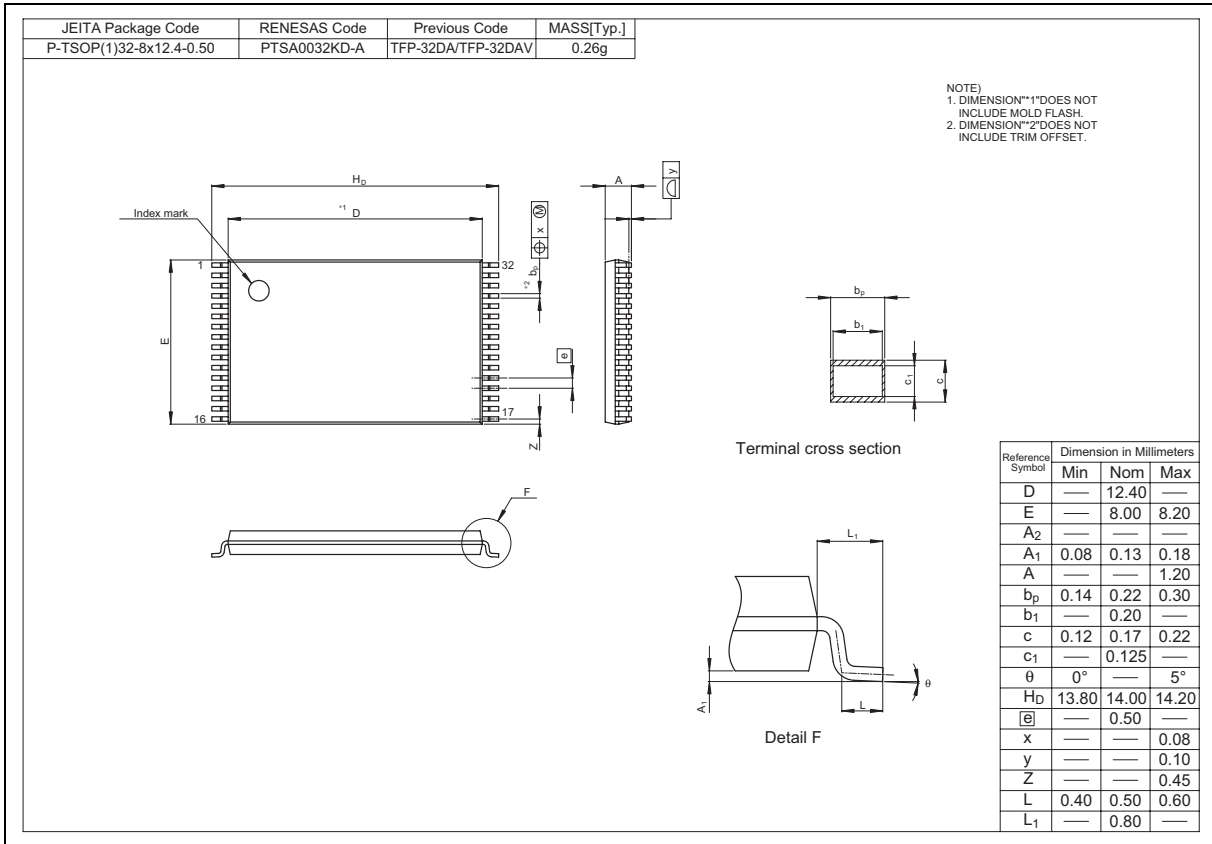

Revision History

HN58C256A/HN58C257A Series Data Sheet

Rev.	Date	Contents of Modification	
		Page	Description
0.0	Jun. 19. 1995	—	Initial issue
1.0	May. 17. 1996	—	Change of format
		4	Absolute Maximun Ratings Addition of note 4
		4	Recommended DC Operating Conditions V_{IH} (min): 3.0 V to 2.2 V
		5	DC Characteristics V_{OH} (min): $V_{CC} \times 0.8$ V to 2.4 V
		6	AC Characteristics Input pulse levels: 0 V to 3.0 V to 0.4 V to 3.0 V Data Polling Timing Waveform Addition of note 1 Toggle bit Waveform Addition of note 4
2.0	Feb. 27. 1997	4	Recommended DC Operating Conditions V_{IL} (max): 0.6 V to 0.8 V
		16	Functional Description Data Protection 3: Addition of note
3.0	May. 20. 1997	16	Functional Description Data Protection 3: Change of Description
4.0	Oct. 24. 1997	8	Timing Waveforms Read Timing Waveform: Correct error
5.00	Nov. 17. 2003	—	Change format issued by Renesas Technology Corp.
		2	Ordering Information Addition of HN58C256AFP-85E, HN58C256AFP-10E, HN58C256AT-85E, HN58C256AT-10E, HN58C257AT-85E, HN58C257AT-10E
		20-23	Package Dimensions FP-28D to FP-28D, FP-28DV TFP-28DB to TFP-28DB, TFP-28DBV TFP-32DA to TFP-32DA, TFP-32DAV
6.00	Oct. 26, 2006	2	Ordering Information Addition of HN58C256AP-85E, HN58C256AP-10E

Notes:

1. This document is provided for reference purposes only so that Renesas customers may select the appropriate Renesas products for their use. Renesas neither makes warranties or representations with respect to the accuracy or completeness of the information contained in this document nor grants any license to any intellectual property rights or any other rights of Renesas or any third party with respect to the information in this document.
2. Renesas shall have no liability for damages or infringement of any intellectual property or other rights arising out of the use of any information in this document, including, but not limited to, product data, diagrams, charts, programs, algorithms, and application circuit examples.
3. You should not use the products or the technology described in this document for the purpose of military applications such as the development of weapons of mass destruction or for the purpose of any other military use. When exporting the products or technology described herein, you should follow the applicable export control laws and regulations, and procedures required by such laws and regulations.
4. All information included in this document such as product data, diagrams, charts, programs, algorithms, and application circuit examples, is current as of the date this document is issued. Such information, however, is subject to change without any prior notice. Before purchasing or using any Renesas products listed in this document, please confirm the latest product information with a Renesas sales office. Also, please pay regular and careful attention to additional and different information to be disclosed by Renesas such as that disclosed through our website. (<http://www.renesas.com>)
5. Renesas has used reasonable care in compiling the information included in this document, but Renesas assumes no liability whatsoever for any damages incurred as a result of errors or omissions in the information included in this document.
6. When using or otherwise relying on the information in this document, you should evaluate the information in light of the total system before deciding about the applicability of such information to the intended application. Renesas makes no representations, warranties or guarantees regarding the suitability of its products for any particular application and specifically disclaims any liability arising out of the application and use of the information in this document or Renesas products.
7. With the exception of products specified by Renesas as suitable for automobile applications, Renesas products are not designed, manufactured or tested for applications or otherwise in systems the failure or malfunction of which may cause a direct threat to human life or create a risk of human injury or which require especially high quality and reliability such as safety systems, or equipment or systems for transportation and traffic, healthcare, combustion control, aerospace and aeronautics, nuclear power, or undersea communication transmission. If you are considering the use of our products for such purposes, please contact a Renesas sales office beforehand. Renesas shall have no liability for damages arising out of the uses set forth above.
8. Notwithstanding the preceding paragraph, you should not use Renesas products for the purposes listed below:
 - (1) artificial life support devices or systems
 - (2) surgical implantations
 - (3) healthcare intervention (e.g., excision, administration of medication, etc.)
 - (4) any other purposes that pose a direct threat to human lifeRenesas shall have no liability for damages arising out of the uses set forth in the above and purchasers who elect to use Renesas products in any of the foregoing applications shall indemnify and hold harmless Renesas Technology Corp., its affiliated companies and their officers, directors, and employees against any and all damages arising out of such applications.
9. You should use the products described herein within the range specified by Renesas, especially with respect to the maximum rating, operating supply voltage range, movement power voltage range, heat radiation characteristics, installation and other product characteristics. Renesas shall have no liability for malfunctions or damages arising out of the use of Renesas products beyond such specified ranges.
10. Although Renesas endeavors to improve the quality and reliability of its products, IC products have specific characteristics such as the occurrence of failure at a certain rate and malfunctions under certain use conditions. Please be sure to implement safety measures to guard against the possibility of physical injury, and injury or damage caused by fire in the event of the failure of a Renesas product, such as safety design for hardware and software including but not limited to redundancy, fire control and malfunction prevention, appropriate treatment for aging degradation or any other applicable measures. Among others, since the evaluation of microcomputer software alone is very difficult, please evaluate the safety of the final products or system manufactured by you.
11. In case Renesas products listed in this document are detached from the products to which the Renesas products are attached or affixed, the risk of accident such as swallowing by infants and small children is very high. You should implement safety measures so that Renesas products may not be easily detached from your products. Renesas shall have no liability for damages arising out of such detachment.
12. This document may not be reproduced or duplicated, in any form, in whole or in part, without prior written approval from Renesas.
13. Please contact a Renesas sales office if you have any questions regarding the information contained in this document, Renesas semiconductor products, or if you have any other inquiries.



RENESAS SALES OFFICES

<http://www.renesas.com>

Refer to "<http://www.renesas.com/en/network>" for the latest and detailed information.

Renesas Technology America, Inc.
450 Holger Way, San Jose, CA 95134-1368, U.S.A
Tel: <1> (408) 382-7500, Fax: <1> (408) 382-7501

Renesas Technology Europe Limited
Dukes Meadow, Millboard Road, Bourne End, Buckinghamshire, SL8 5FH, U.K.
Tel: <44> (1628) 585-100, Fax: <44> (1628) 585-900

Renesas Technology (Shanghai) Co., Ltd.
Unit 204, 205, AZIACenter, No.1233 Lujiazui Ring Rd, Pudong District, Shanghai, China 200120
Tel: <86> (21) 5877-1818, Fax: <86> (21) 6887-7898

Renesas Technology Hong Kong Ltd.
7th Floor, North Tower, World Finance Centre, Harbour City, 1 Canton Road, Tsimshatsui, Kowloon, Hong Kong
Tel: <852> 2265-6688, Fax: <852> 2730-6071

Renesas Technology Taiwan Co., Ltd.
10th Floor, No.99, Fushing North Road, Taipei, Taiwan
Tel: <886> (2) 2715-2888, Fax: <886> (2) 2713-2999

Renesas Technology Singapore Pte. Ltd.
1 Harbour Front Avenue, #06-10, Keppel Bay Tower, Singapore 098632
Tel: <65> 6213-0200, Fax: <65> 6278-8001

Renesas Technology Korea Co., Ltd.
Kukje Center Bldg. 18th Fl., 191, 2-ka, Hangang-ro, Yongsan-ku, Seoul 140-702, Korea
Tel: <82> (2) 796-3115, Fax: <82> (2) 796-2145

Renesas Technology Malaysia Sdn. Bhd
Unit 906, Block B, Menara Amcorp, Amcorp Trade Centre, No.18, Jalan Persiaran Barat, 46050 Petaling Jaya, Selangor Darul Ehsan, Malaysia
Tel: <603> 7955-9390, Fax: <603> 7955-9510

To our customers,

Old Company Name in Catalogs and Other Documents

On April 1st, 2010, NEC Electronics Corporation merged with Renesas Technology Corporation, and Renesas Electronics Corporation took over all the business of both companies. Therefore, although the old company name remains in this document, it is a valid Renesas Electronics document. We appreciate your understanding.

Renesas Electronics website: <http://www.renesas.com>

April 1st, 2010
Renesas Electronics Corporation

Issued by: Renesas Electronics Corporation (<http://www.renesas.com>)

Send any inquiries to <http://www.renesas.com/inquiry>.

Notice

1. All information included in this document is current as of the date this document is issued. Such information, however, is subject to change without any prior notice. Before purchasing or using any Renesas Electronics products listed herein, please confirm the latest product information with a Renesas Electronics sales office. Also, please pay regular and careful attention to additional and different information to be disclosed by Renesas Electronics such as that disclosed through our website.
2. Renesas Electronics does not assume any liability for infringement of patents, copyrights, or other intellectual property rights of third parties by or arising from the use of Renesas Electronics products or technical information described in this document. No license, express, implied or otherwise, is granted hereby under any patents, copyrights or other intellectual property rights of Renesas Electronics or others.
3. You should not alter, modify, copy, or otherwise misappropriate any Renesas Electronics product, whether in whole or in part.
4. Descriptions of circuits, software and other related information in this document are provided only to illustrate the operation of semiconductor products and application examples. You are fully responsible for the incorporation of these circuits, software, and information in the design of your equipment. Renesas Electronics assumes no responsibility for any losses incurred by you or third parties arising from the use of these circuits, software, or information.
5. When exporting the products or technology described in this document, you should comply with the applicable export control laws and regulations and follow the procedures required by such laws and regulations. You should not use Renesas Electronics products or the technology described in this document for any purpose relating to military applications or use by the military, including but not limited to the development of weapons of mass destruction. Renesas Electronics products and technology may not be used for or incorporated into any products or systems whose manufacture, use, or sale is prohibited under any applicable domestic or foreign laws or regulations.
6. Renesas Electronics has used reasonable care in preparing the information included in this document, but Renesas Electronics does not warrant that such information is error free. Renesas Electronics assumes no liability whatsoever for any damages incurred by you resulting from errors in or omissions from the information included herein.
7. Renesas Electronics products are classified according to the following three quality grades: “Standard”, “High Quality”, and “Specific”. The recommended applications for each Renesas Electronics product depends on the product’s quality grade, as indicated below. You must check the quality grade of each Renesas Electronics product before using it in a particular application. You may not use any Renesas Electronics product for any application categorized as “Specific” without the prior written consent of Renesas Electronics. Further, you may not use any Renesas Electronics product for any application for which it is not intended without the prior written consent of Renesas Electronics. Renesas Electronics shall not be in any way liable for any damages or losses incurred by you or third parties arising from the use of any Renesas Electronics product for an application categorized as “Specific” or for which the product is not intended where you have failed to obtain the prior written consent of Renesas Electronics. The quality grade of each Renesas Electronics product is “Standard” unless otherwise expressly specified in a Renesas Electronics data sheets or data books, etc.
 - “Standard”: Computers; office equipment; communications equipment; test and measurement equipment; audio and visual equipment; home electronic appliances; machine tools; personal electronic equipment; and industrial robots.
 - “High Quality”: Transportation equipment (automobiles, trains, ships, etc.); traffic control systems; anti-disaster systems; anti-crime systems; safety equipment; and medical equipment not specifically designed for life support.
 - “Specific”: Aircraft; aerospace equipment; submersible repeaters; nuclear reactor control systems; medical equipment or systems for life support (e.g. artificial life support devices or systems), surgical implantations, or healthcare intervention (e.g. excision, etc.), and any other applications or purposes that pose a direct threat to human life.
8. You should use the Renesas Electronics products described in this document within the range specified by Renesas Electronics, especially with respect to the maximum rating, operating supply voltage range, movement power voltage range, heat radiation characteristics, installation and other product characteristics. Renesas Electronics shall have no liability for malfunctions or damages arising out of the use of Renesas Electronics products beyond such specified ranges.
9. Although Renesas Electronics endeavors to improve the quality and reliability of its products, semiconductor products have specific characteristics such as the occurrence of failure at a certain rate and malfunctions under certain use conditions. Further, Renesas Electronics products are not subject to radiation resistance design. Please be sure to implement safety measures to guard them against the possibility of physical injury, and injury or damage caused by fire in the event of the failure of a Renesas Electronics product, such as safety design for hardware and software including but not limited to redundancy, fire control and malfunction prevention, appropriate treatment for aging degradation or any other appropriate measures. Because the evaluation of microcomputer software alone is very difficult, please evaluate the safety of the final products or system manufactured by you.
10. Please contact a Renesas Electronics sales office for details as to environmental matters such as the environmental compatibility of each Renesas Electronics product. Please use Renesas Electronics products in compliance with all applicable laws and regulations that regulate the inclusion or use of controlled substances, including without limitation, the EU RoHS Directive. Renesas Electronics assumes no liability for damages or losses occurring as a result of your noncompliance with applicable laws and regulations.
11. This document may not be reproduced or duplicated, in any form, in whole or in part, without prior written consent of Renesas Electronics.
12. Please contact a Renesas Electronics sales office if you have any questions regarding the information contained in this document or Renesas Electronics products, or if you have any other inquiries.

(Note 1) “Renesas Electronics” as used in this document means Renesas Electronics Corporation and also includes its majority-owned subsidiaries.

(Note 2) “Renesas Electronics product(s)” means any product developed or manufactured by or for Renesas Electronics.