



Features

- ESD Protection for 1 Line with Bi-directional.
- Provide ESD protection for each line to
IEC 61000-4-2 (ESD) $\pm 16\text{kV}$ (air / contact)
IEC 61000-4-5 (Lightning) 4A (8/20 μs)
- **Ultra low capacitance: 0.5pF typical**
- Suitable for, **5V and below**, operating voltage applications
- **0201 small CSP package** saves board space
- Protect one I/O line or one power line
- Fast turn-on and low clamping voltage
- Solid-state silicon-avalanche and active circuit triggering technology
- **Green part**

Applications

- Mobile Phones
- Hand Held Portable Applications
- Computer Interfaces Protection
- Microprocessors Protection
- Serial and Parallel Port Protection
- Control Signal Lines Protection
- Power Lines on PCB Protection
- Latchup Protection

Description

AZ5B85-01B is a design which includes a bi-directional ESD rated clamping cell to protect one power line, or one control line, or one high speed data line in an electronic system. The AZ5B85-01B has been specifically designed to protect sensitive components which are

connected to data and transmission lines from over-voltage caused by Electrostatic Discharging (ESD), Lightning, and Cable Discharge Event (CDE).

AZ5B85-01B is a unique design which includes proprietary clamping cell in a single package. During transient conditions, the proprietary clamping cell prevents over-voltage on the power line or control/data lines, protecting any downstream components.

AZ5B85-01B may be used to meet the ESD immunity requirements of IEC 61000-4-2, Level 4 ($\pm 15\text{kV}$ air, $\pm 8\text{kV}$ contact discharge).

Circuit Diagram / Pin Configuration

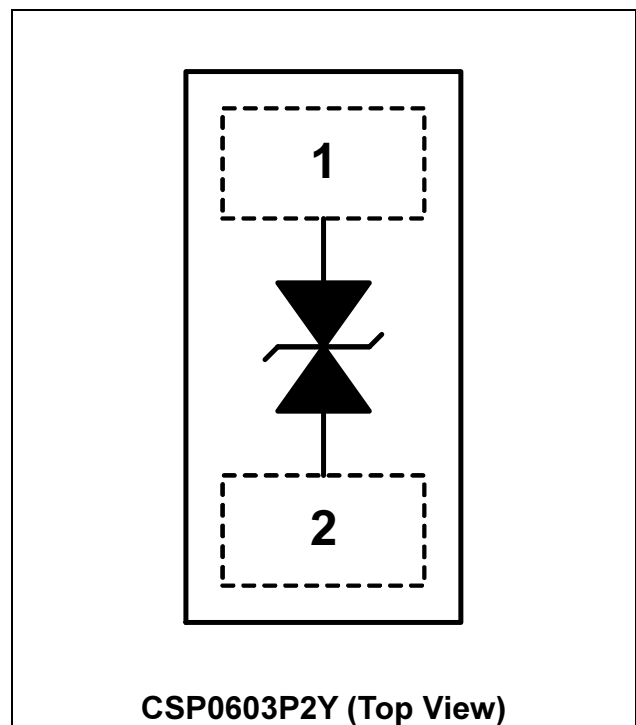



SPECIFICATIONS

ABSOLUTE MAXIMUM RATINGS			
PARAMETER	SYMBOL	RATING	UNITS
Peak Pulse Current (tp =8/20μs)	I _{PP}	4	A
Operating Supply Voltage (pin-1 to pin-2)	V _{DC}	±5.5	V
Pin-1 to pin-2 ESD per IEC 61000-4-2 (Air)	V _{ESD-1}	±16	kV
Pin-1 to pin-2 ESD per IEC 61000-4-2 (Contact)	V _{ESD-2}	±16	
Lead Soldering Temperature	T _{SOL}	260 (10 sec.)	°C
Operating Temperature	T _{OP}	-55 to +85	°C
Storage Temperature	T _{STO}	-55 to +150	°C

ELECTRICAL CHARACTERISTICS						
PARAMETER	SYMBOL	CONDITIONS	MINI	TYP	MAX	UNITS
Reverse Stand-Off Voltage	V _{RWM}	T=25 °C.	-5		5	V
Reverse Leakage Current	I _{Leak}	V _{RWM} = ±5V, T=25 °C.			100	nA
Reverse Breakdown Voltage	V _{BV}	I _{BV} = 1mA, T=25 °C.	6		9	V
ESD Clamping Voltage (Note 1)	V _{clamp}	IEC 61000-4-2 +8kV (I _{TLP} = 16A), Contact mode, T=25 °C.		11		V
ESD Dynamic Turn-on Resistance	R _{dynamic}	IEC 61000-4-2 0~+8kV, T=25 °C, Contact mode.		0.25		Ω
Channel Input Capacitance	C _{IN}	V _R = 2.5V, f = 1MHz, T=25 °C.		0.5	0.65	pF

Note 1: ESD Clamping Voltage was measured by Transmission Line Pulsing (TLP) System.

TLP conditions: Z₀= 50Ω, t_p= 100ns, t_r= 1ns.



Typical Characteristics

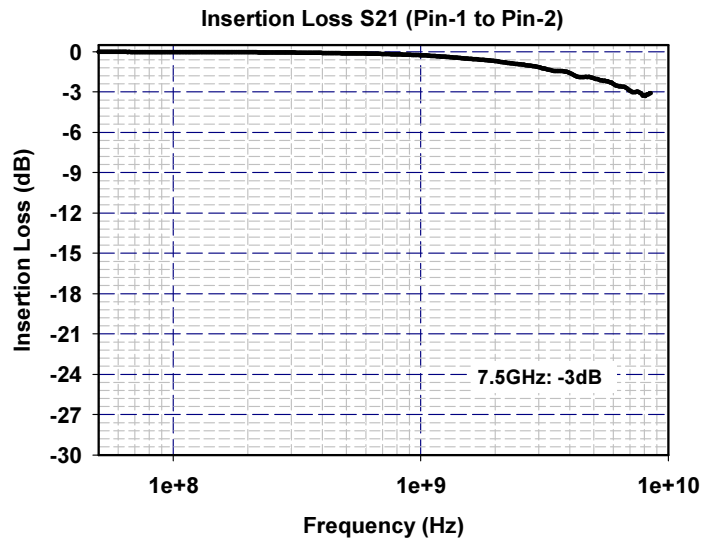
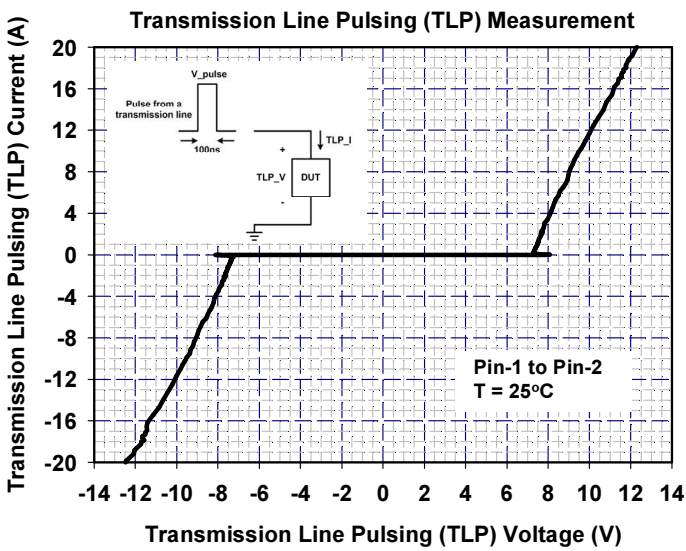
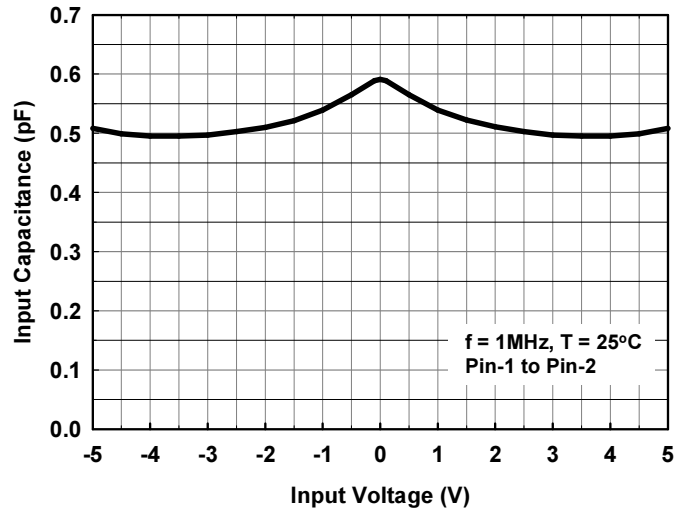
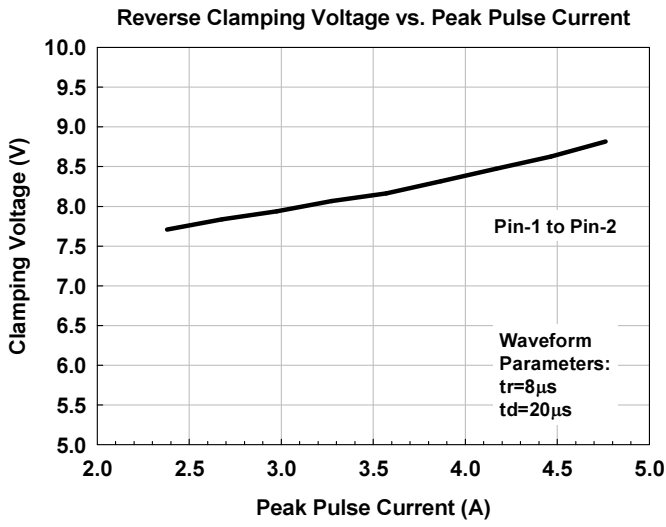



Applications Information

The AZ5B85-01B is designed to protect one line against System ESD/Lightning pulses by clamping it to an acceptable reference. It provides bi-directional protection.

The usage of the AZ5B85-01B is shown in Fig. 1. Protected line, such as data line, control line, or power line, is connected at pin 1. The pin 2 is connected to a ground plane on the board. In order to minimize parasitic inductance in the board traces, all path lengths connected to the pins of AZ5B85-01B should be kept as short as possible.

In order to obtain enough suppression of ESD induced transient, good circuit board is critical.

Thus, the following guidelines are recommended:

- Minimize the path length between the protected lines and the AZ5B85-01B.
- Place the AZ5B85-01B near the input terminals or connectors to restrict transient coupling.
- The ESD current return path to ground should be kept as short as possible.
- Use ground planes whenever possible.

NEVER route critical signals near board edges and near the lines which the ESD transient easily injects to.

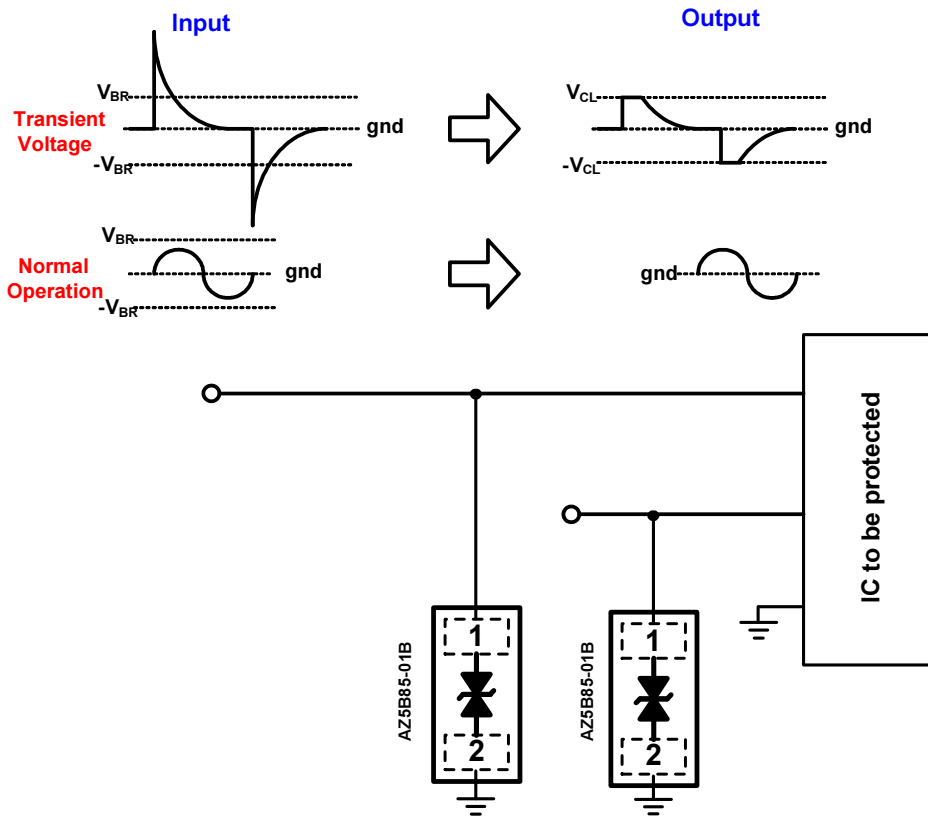

Fig. 1



Fig. 2 shows another simplified example of using AZ5B85-01B to protect the control line, high speed data line, and power line from ESD transient stress.

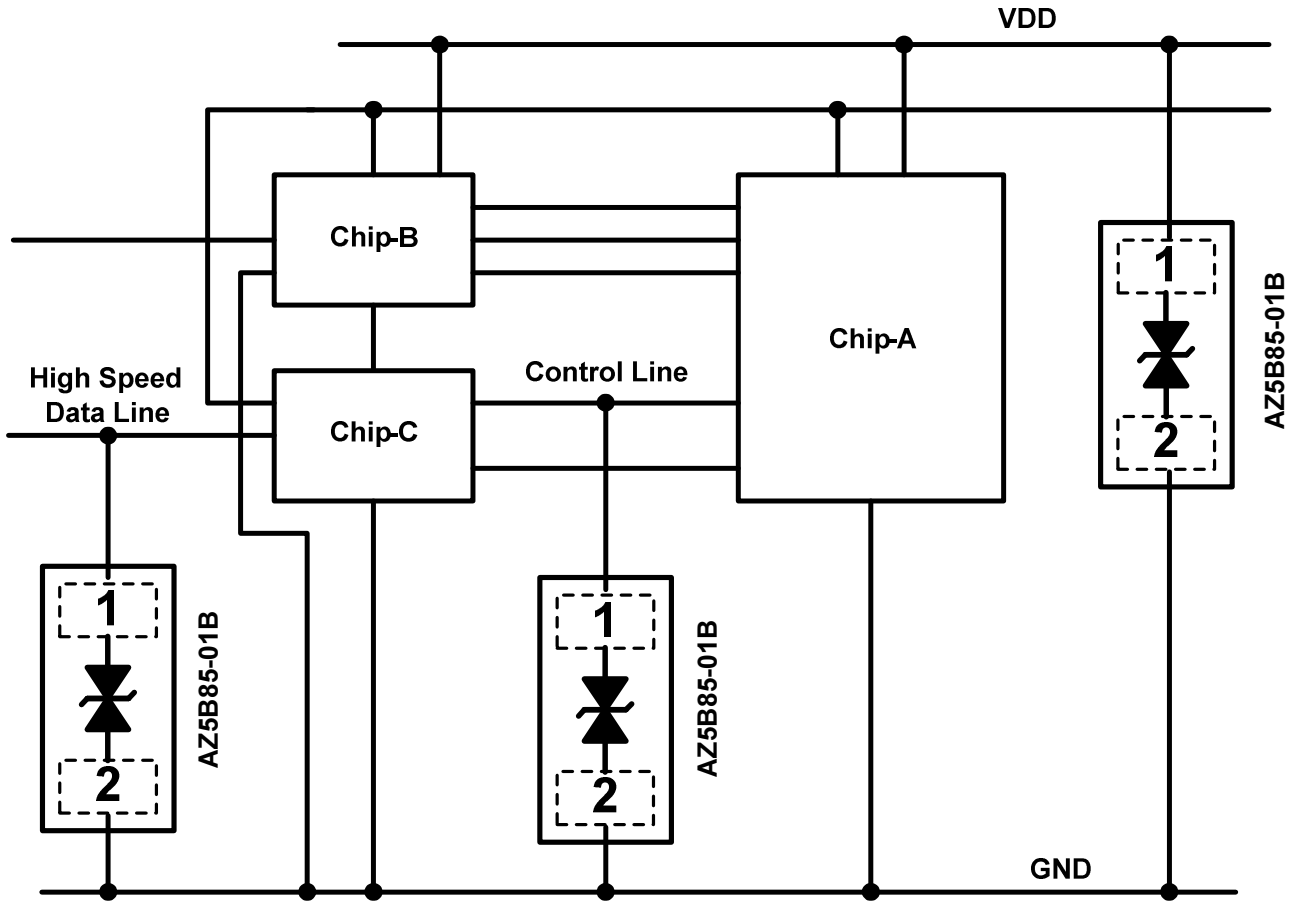
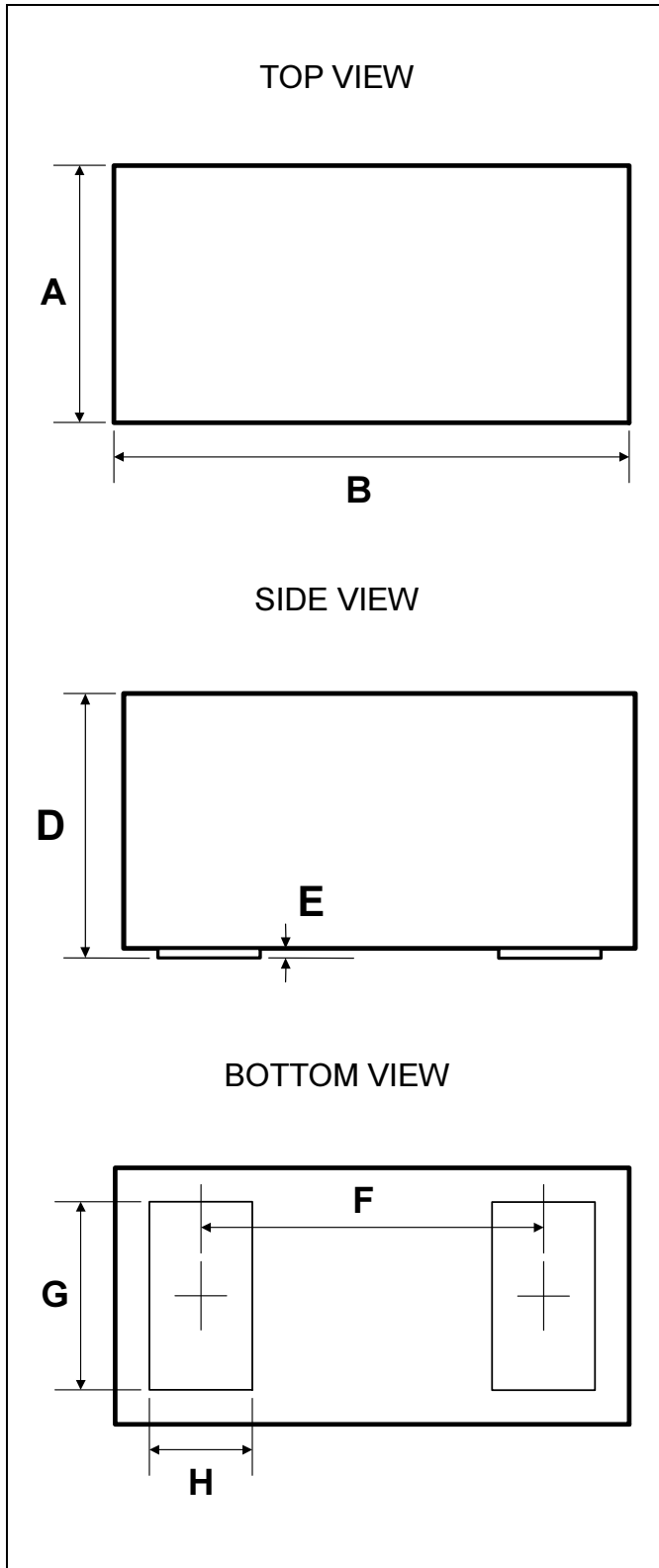

Fig. 2

Mechanical Details

CSP0603P2Y

PACKAGE DIAGRAMS



PACKAGE DIMENSIONS

Symbol	Millimeters		
	MIN.	TYP.	MAX.
A	0.275	0.300	0.325
B	0.575	0.600	0.625
D	0.256	0.276	0.296
E		0.011	
F		0.400	
G	0.210	0.220	0.230
H	0.110	0.120	0.130

LAND LAYOUT

Unit: mm

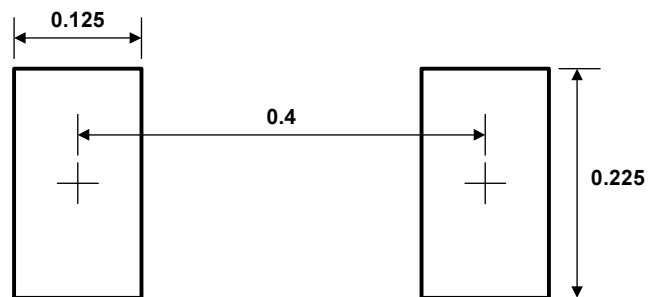

Notes:

This LAND LAYOUT is for reference purposes only. Please consult your manufacturing partners to ensure your company's PCB design guidelines are met.

MARKING CODE

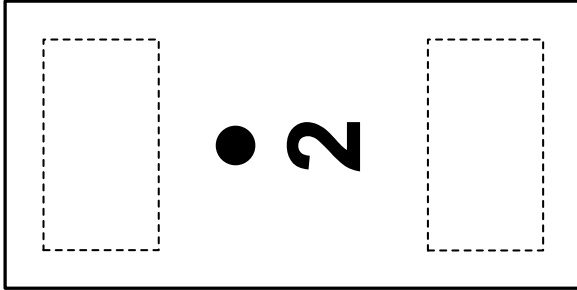

Part Number	Marking Code
AZ5B85-01B.R7G (Green Part)	2

Note : Green means Pb-free, RoHS, and Halogen free compliant.

2 = Device Code

Ordering Information

PN#	Material	Type	Reel size	MOQ	MOQ/internal box	MOQ/carton
AZ5B85-01B.R7G	Green	T/R	7 inch	15,000/reel	4 reels = 60,000/box	6 boxes = 360,000/carton

Revision History

Revision	Modification Description
Revision 2015/07/17	Preliminary Release.
Revision 2015/10/06	Update the maximum spec. of Leakage Current.
Revision 2016/03/16	Formal Release.