

# Ultralow-Power NTSC/PAL/SECAM Video Decoder

Check for Samples: [TVP5151](#)

## 1 Introduction

### 1.1 Features

- Accepts NTSC (J, M, 4.43), PAL (B, D, G, H, I, M, N, Nc), and SECAM (B, D, G, K, K1, L) Video
- Supports ITU-R BT.601 Standard Sampling
- High-Speed 9-Bit Analog-to-Digital Converter (ADC)
- Two Composite Inputs or One S-Video Input
- Fully Differential CMOS Analog Preprocessing Channels With Clamping and Automatic Gain Control (AGC) for Best Signal-to-Noise (S/N) Performance
- Ultralow Power Consumption
- 48-Terminal PBGA Package (ZQC) or 32-Terminal TQFP Package (PBS)
- Power-Down Mode: <1 mW
- Brightness, Saturation, Hue, and Sharpness Control Through I<sup>2</sup>C
- Complementary 4-Line (3-H Delay) Adaptive Comb Filters for Both Cross-Luminance and Cross-Chrominance Noise Reduction
- Patented Architecture for Locking to Weak, Noisy, or Unstable Signals
- Single 27.000-MHz Crystal for All Standards
- Internal Phase-Locked Loop (PLL) for Line-Locked Clock and Sampling
- Subcarrier Genlock Output for Synchronizing Color Subcarrier of External Encoder
- Variable Digital I/O Supply Voltage Range from 1.8 V to 3.3 V
- Standard Programmable Video Output Formats
  - ITU-R BT.656, 8-Bit 4:2:2 With Embedded Syncs
  - 8-Bit 4:2:2 With Discrete Syncs
- Macrovision™ Copy Protection Detection
- Advanced Programmable Video Output Formats
  - 2× Oversampled Raw Vertical Blanking Interval (VBI) Data During Active Video
  - Sliced VBI Data During Horizontal Blanking or Active Video
- VBI Modes Supported
  - Teletext (NABTS, WST)
  - Closed-Caption Decode With FIFO and Extended Data Services (XDS)
  - Wide Screen Signaling, Video Program System, CGMS-A, Vertical Interval Time Code
  - Gemstar 1x/2x Electronic Program Guide Compatible Mode
  - Custom Configuration Mode That Allows User to Program Slice Engine for Unique VBI Data Signals
- Power-On Reset
- Industrial Temperature Range (TVP5151): –40°C to 85°C

### 1.2 Description

The TVP5151 device is an ultralow-power NTSC/PAL/SECAM video decoder. Available in a space-saving 48-terminal PBGA package or a 32-terminal TQFP package, the TVP5151 decoder converts NTSC, PAL, and SECAM video signals to 8-bit ITU-R BT.656 format. Discrete syncs are also available. The optimized architecture of the TVP5151 decoder allows for ultralow power consumption. The decoder consumes 138-mW power under typical operating conditions and consumes less than 1 mW in power-down mode, considerably increasing battery life in portable applications. The decoder uses just one crystal for all supported standards. The TVP5151 decoder can be programmed using an I<sup>2</sup>C serial interface.

The TVP5151 decoder converts baseband analog video into digital YCbCr 4:2:2 component video. Composite and S-video inputs are supported. The TVP5151 decoder includes one 9-bit analog-to-digital converter (ADC) with 2× sampling. Sampling is ITU-R BT.601 (27.0 MHz, generated from the 27.000-MHz crystal or oscillator input) and is line locked. The output formats can be 8-bit 4:2:2 or 8-bit ITU-R BT.656 with embedded synchronization.



Please be aware that an important notice concerning availability, standard warranty, and use in critical applications of Texas Instruments semiconductor products and disclaimers thereto appears at the end of this data sheet.

The TVP5151 decoder utilizes Texas Instruments patented technology for locking to weak, noisy, or unstable signals. A Genlock/real-time control (RTC) output is generated for synchronizing downstream video encoders.

Complementary four-line adaptive comb filtering is available for both the luminance and chrominance data paths to reduce both cross-luminance and cross-chrominance artifacts; a chrominance trap filter is also available.

Video characteristics including hue, brightness, saturation, and sharpness may be programmed using the industry standard I<sup>2</sup>C serial interface. The TVP5151 decoder generates synchronization, blanking, lock, and clock signals in addition to digital video outputs. The TVP5151 decoder includes methods for advanced vertical blanking interval (VBI) data retrieval. The VBI data processor slices, parses, and performs error checking on teletext, closed caption, and other data in several formats.

The TVP5151 decoder detects copy-protected input signals according to the Macrovision™ standard and detects Type 1, 2, 3, and colorstripe processes.

The main blocks of the TVP5151 decoder include:

- Robust sync detector
- ADC with analog processor
- Y/C separation using four-line adaptive comb filter
- Chrominance processor
- Luminance processor
- Video clock/timing processor and power-down control
- Output formatter
- I<sup>2</sup>C interface
- VBI data processor
- Macrovision detection for composite and S-video

### 1.3 Applications

The following is a partial list of suggested applications:

- Digital televisions
- PDAs
- Notebook PCs
- Cell phones
- Video recorder/players
- Internet appliances/web pads
- Handheld games
- Surveillance
- Portable navigation
- Portable video projectors

## 1.4 Related Products

- TVP5150AM1
- TVP5154A
- TVP5146M2
- TVP5147M1
- TVP5158

## 1.5 Trademarks

TI and MicroStar Junior are trademarks of Texas Instruments.

Macrovision is a trademark of Macrovision Corporation.

Gemstar is a trademark of Gemstar-TV Guide International.

Other trademarks are the property of their respective owners.

## 1.6 Document Conventions

Throughout this data manual, several conventions are used to convey information. These conventions are:

- To identify a binary number or field, a lower case b follows the numbers. For example, 000b is a 3-bit binary field.
- To identify a hexadecimal number or field, a lower case h follows the numbers. For example, 8AFh is a 12-bit hexadecimal field.
- All other numbers that appear in this document that do not have either a b or h following the number are assumed to be decimal format.
- If the signal or terminal name has a bar above the name (for example,  $\overline{\text{RESETB}}$ ), this indicates the logical NOT function. When asserted, this signal is a logic low, 0, or 0b.
- RSVD indicates that the referenced item is reserved.

## 1.7 Ordering Information

T <sub>A</sub>	PACKAGED DEVICES <sup>(1)</sup> <sup>(2)</sup>	PACKAGE OPTION
0°C to 70°C	TVP5151PBS	Tray
	TVP5151PBSR	Tape and reel
	TVP5151ZQC	Tray
	TVP5151ZQCR	Tape and reel
–40°C to 85°C	TVP5151IPBS	Tray
	TVP5151IPBSR	Tape and reel

(1) For the most current package and ordering information, see the Package Option Addendum at the end of this document, or see the TI web site at [www.ti.com](http://www.ti.com).

(2) Package drawings, thermal data, and symbolization are available at [www.ti.com/packaging](http://www.ti.com/packaging).

<b>1</b>	<b>Introduction</b>	<b><a href="#">1</a></b>	3.13	Active Video (AVID) Cropping	<a href="#">16</a>
1.1	Features	<a href="#">1</a>	3.14	Embedded Syncs	<a href="#">17</a>
1.2	Description	<a href="#">1</a>	3.15	I <sup>2</sup> C Host Interface	<a href="#">18</a>
1.3	Applications	<a href="#">2</a>	3.16	Clock Circuits	<a href="#">21</a>
1.4	Related Products	<a href="#">3</a>	3.17	Genlock Control (GLCO) and RTC	<a href="#">22</a>
1.5	Trademarks	<a href="#">3</a>	3.18	Reset and Power Down	<a href="#">23</a>
1.6	Document Conventions	<a href="#">3</a>	3.19	Reset Sequence	<a href="#">25</a>
1.7	Ordering Information	<a href="#">3</a>	3.20	Internal Control Registers	<a href="#">26</a>
<b>2</b>	<b>Device Details</b>	<b><a href="#">5</a></b>	3.21	Register Definitions	<a href="#">29</a>
2.1	Functional Block Diagram	<a href="#">5</a>	<b>4</b>	<b>Electrical Specifications</b>	<b><a href="#">71</a></b>
2.2	Terminal Assignments	<a href="#">6</a>	4.1	Absolute Maximum Ratings	<a href="#">71</a>
2.3	Terminal Functions	<a href="#">7</a>	4.2	Recommended Operating Conditions	<a href="#">71</a>
<b>3</b>	<b>Functional Description</b>	<b><a href="#">9</a></b>	4.3	Reference Clock Specifications	<a href="#">71</a>
3.1	Analog Front End	<a href="#">9</a>	4.4	Electrical Characteristics	<a href="#">72</a>
3.2	Composite Processing Block Diagram	<a href="#">9</a>	4.5	DC Electrical Characteristics	<a href="#">72</a>
3.3	Adaptive Comb Filtering	<a href="#">10</a>	4.6	Analog Electrical Characteristics	<a href="#">72</a>
3.4	Color Low-Pass Filter	<a href="#">11</a>	4.7	Clocks, Video Data, Sync Timing	<a href="#">73</a>
3.5	Luminance Processing	<a href="#">12</a>	4.8	I <sup>2</sup> C Host Interface Timing	<a href="#">74</a>
3.6	Chrominance Processing	<a href="#">12</a>	4.9	Thermal Specifications	<a href="#">74</a>
3.7	Timing Processor	<a href="#">12</a>	<b>5</b>	<b>Example Register Settings</b>	<b><a href="#">75</a></b>
3.8	VBI Data Processor (VDP)	<a href="#">12</a>	5.1	Example 1	<a href="#">75</a>
3.9	VBI FIFO and Ancillary Data in Video Stream	<a href="#">13</a>	5.2	Example 2	<a href="#">76</a>
3.10	Raw Video Data Output	<a href="#">14</a>	<b>6</b>	<b>Application Information</b>	<b><a href="#">77</a></b>
3.11	Output Formatter	<a href="#">14</a>	6.1	Application Example	<a href="#">77</a>
3.12	Synchronization Signals	<a href="#">14</a>	<b>7</b>	<b>Revision History</b>	<b><a href="#">78</a></b>

## 2 Device Details

### 2.1 Functional Block Diagram

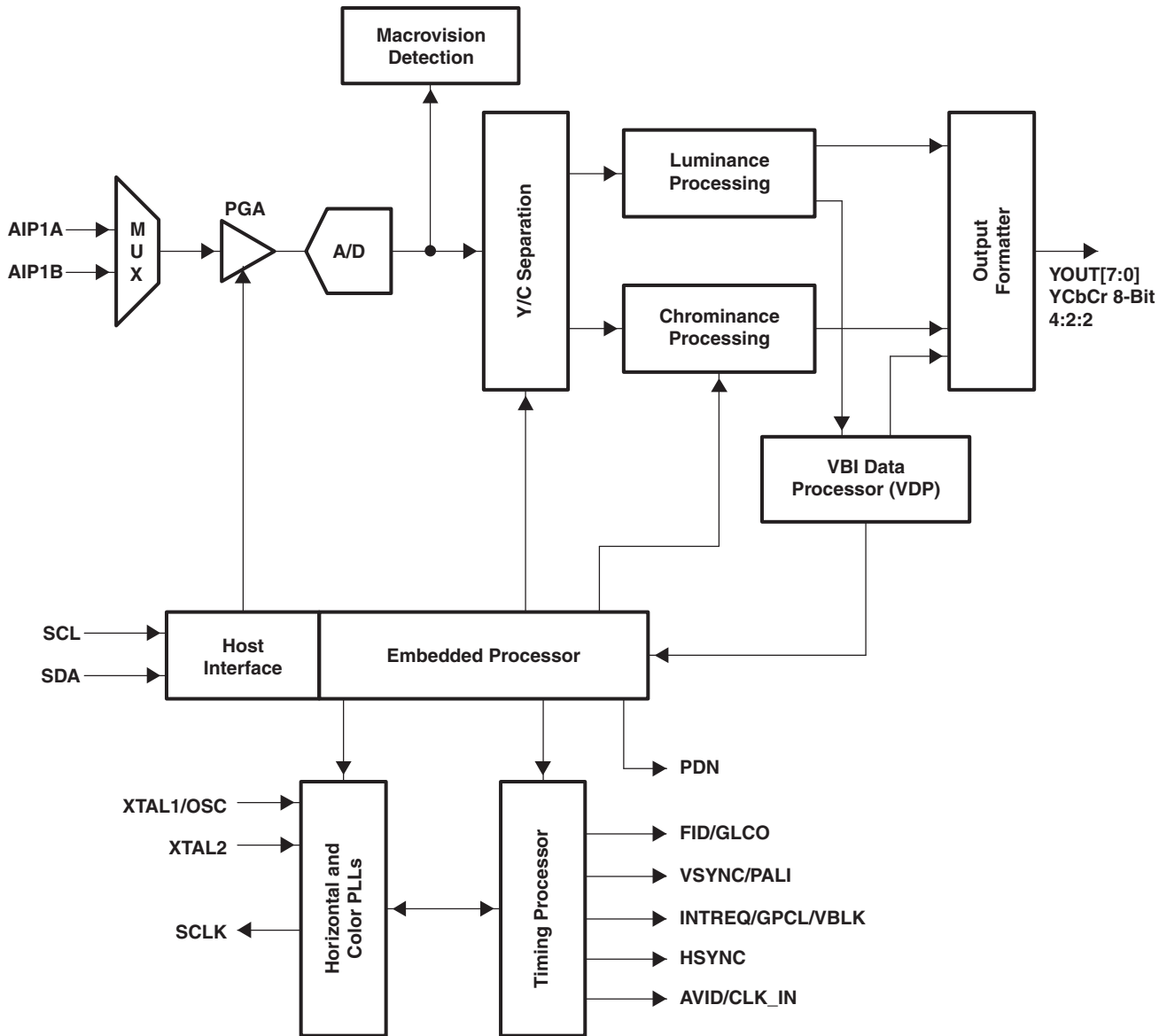

Figure 2-1. Functional Block Diagram

## 2.2 Terminal Assignments

The TVP5151 video decoder is packaged in a 48-terminal PBGA package or a 32-terminal TQFP package. Figure 2-2 shows the terminal diagrams for both packages. Table 2-1 gives a description of the terminals.

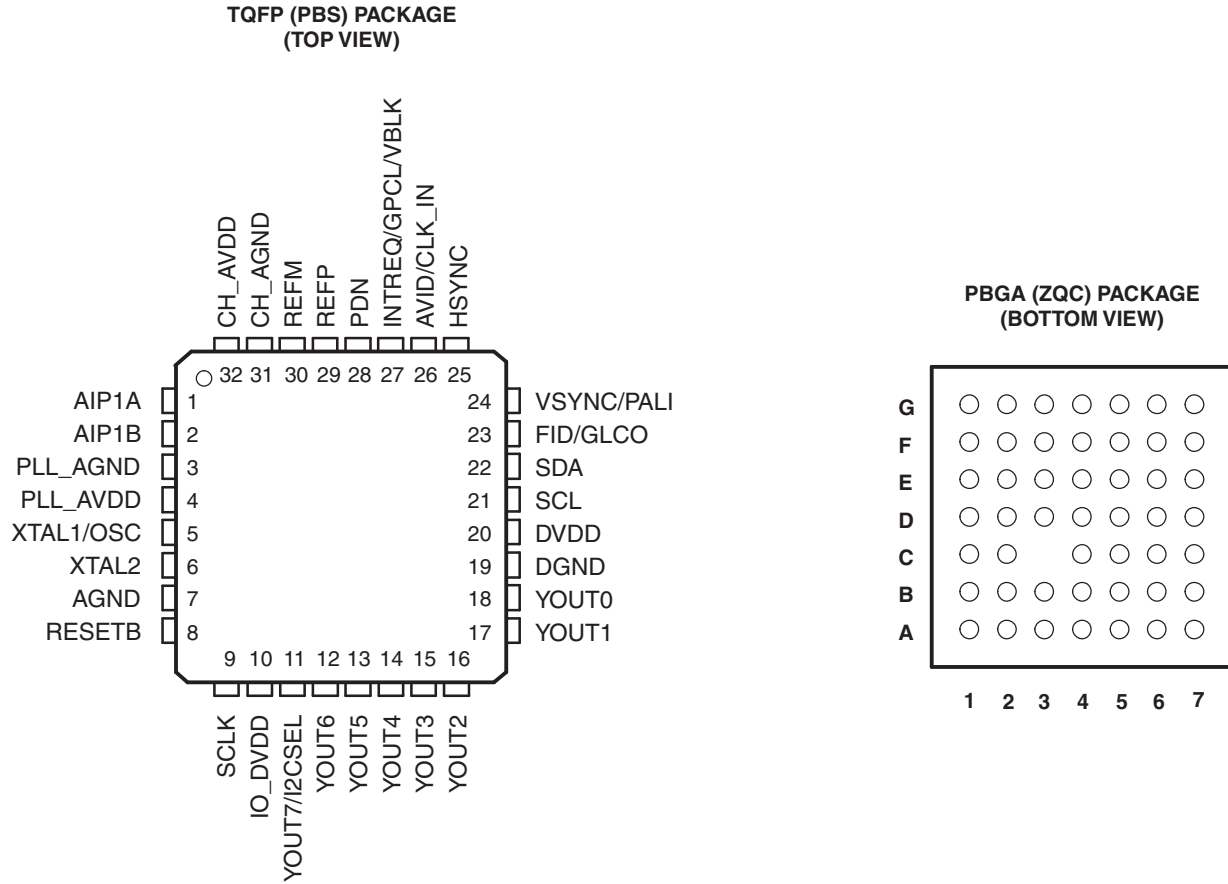

Figure 2-2. Terminal Diagrams

## 2.3 Terminal Functions

**Table 2-1. Terminal Functions**

TERMINAL			I/O	DESCRIPTION
NAME	NO.			
	ZQC	PBS		
<b>Analog Section</b>				
AGND	E1	7	G	Substrate. Connect to analog ground.
AIP1A	A1	1	I	Analog input. Connect to the video analog input via 0.1- $\mu$ F capacitor. The maximum input range is 0-0.75 $V_{PP}$ , and may require an attenuator to reduce the input amplitude to the desired level. If not used, connect to AGND via a 0.1- $\mu$ F capacitor (see <a href="#">Figure 6-1</a> ).
AIP1B	B1	2	I	Analog input. Connect to the video analog input via 0.1- $\mu$ F capacitor. The maximum input range is 0-0.75 $V_{PP}$ , and may require an attenuator to reduce the input amplitude to the desired level. If not used, connect to AGND via a 0.1- $\mu$ F capacitor (see <a href="#">Figure 6-1</a> ).
CH_AGND	A3	31	G	Analog ground
CH_AVDD	A2	32	P	Analog supply. Connect to 1.8-V analog supply.
NC	B2, B3, B6, C4, C5, D3–D6, E2–E5, F2, F5, F6	–	–	No connect
PLL_AGND	C2	3	G	PLL ground. Connect to analog ground.
PLL_AVDD	C1	4	P	PLL supply. Connect to 1.8-V analog supply.
REFM	A4	30	O	A/D reference negative output. Connect to analog ground through a 1- $\mu$ F capacitor. Also, it is recommended to connect directly to REFP through a 1- $\mu$ F capacitor (see <a href="#">Figure 6-1</a> ).
REFP	B4	29	O	A/D reference positive output. Connect to analog ground through a 1- $\mu$ F capacitor (see <a href="#">Figure 6-1</a> ).
XTAL1/OSC	D2	5	I	External clock reference input. Connect to analog ground if an external single-ended oscillator is connected to AVID/CLK_IN pin.
XTAL2	D1	6	O	External clock reference output. Not connected if XTAL1 or CLK_IN is driven by an external single-ended oscillator.
<b>Digital Section</b>				
AVID/CLK_IN	A6	26	I/O	Active video indicator output/external clk input When XTAL1 is used as a reference clock and this terminal is left unconnected, this terminal is internally pulled down. When XTAL1 is used as a reference clock and AVID output is required, this pin must be low until terminal is configured as an output. This may be dependent on external circuitry connected to this terminal. When XTAL 1 is connected to ground, CLK_IN may be connected to an external single-ended oscillator from a 1.8-V to 3.3-V compatible clock signal depending on IO_DVDD voltage.
DGND	E6	19	G	Digital ground
DVDD	E7	20	P	Digital supply. Connect to 1.8-V digital supply.
FID/GLCO	C6	23	O	FID: Odd/even field indicator or vertical lock indicator. For the odd/even indicator, a 1 indicates the odd field. GLCO: This serial output carries color PLL information. A slave device can decode the information to allow chrominance frequency control from the TVP5151 decoder. Data is transmitted at the SCLK rate in Genlock mode. In RTC mode, SCLK/4 is used.
HSYNC	A7	25	O	Horizontal synchronization signal

**Table 2-1. Terminal Functions (continued)**

TERMINAL			I/O	DESCRIPTION
NAME	NO.			
	ZQC	PBS		
INTREQ/ GPCL/VBLK	B5	27	O	<p>This terminal has three functions selectable by bit 7 of I<sup>2</sup>C register 03h and bit 1 of I<sup>2</sup>C register 0Fh:</p> <ul style="list-style-type: none"> <li>• INTREQ: Interrupt request output</li> <li>• GPCL: General-purpose control logic output. In this mode, the state of terminal 27 is directly programmed via I<sup>2</sup>C.</li> <li>• VBLK: Vertical blanking output. In this mode, terminal 27 indicates the vertical blanking interval of the output video. The beginning and end times of this signal are programmable via I<sup>2</sup>C.</li> </ul> <p>An external pullup or pulldown resistor is required under certain conditions (see <a href="#">Figure 6-1</a>).</p>
IO_DVDD	G2	10	P	Digital output supply, 1.8 V to 3.3 V
SCLK	G1	9	O	System clock at 2x the frequency of the pixel clock.
PDN	A5	28	I	Power-down terminal (active low). Puts the decoder in standby mode. Preserves the value of the registers.
RESETB	F1	8	I	Active-low reset. RESETB can be used only when PDN = 1. When RESETB is pulled low, it resets all the registers and restarts the internal microprocessor.
SCL	D7	21	I/O	I <sup>2</sup> C serial clock (open drain)
SDA	C7	22	I/O	I <sup>2</sup> C serial data (open drain)
VSYNC/PALI	B7	24	O	<p>VSYNC: Vertical synchronization signal</p> <p>PALI: PAL line indicator or horizontal lock indicator. For the PAL line indicator:</p> <ul style="list-style-type: none"> <li>1 = Noninverted line</li> <li>0 = Inverted line</li> </ul>
YOUT[6:0]	G3 F4 G4 G5 G6 G7 F7	12 13 14 15 16 17 18	O	ITU-R BT.656 output/YCbCr 4:2:2 output with discrete syncs
YOUT7/I2CSEL	F3	11	I/O	<p>I2CSEL: Determines address for I<sup>2</sup>C (sampled during reset). A pullup or pulldown resistor is needed (&gt;1 kΩ) to program the terminal to the desired address.</p> <ul style="list-style-type: none"> <li>1 = Address is BAh</li> <li>0 = Address is B8h</li> </ul> <p>YOUT7: Most significant bit (MSB) of ITU-R BT.656 output/YCbCr 4:2:2 output</p>



## 3 Functional Description

### 3.1 Analog Front End

The TVP5151 decoder has an analog input channel that accepts two video inputs that are ac-coupled. The decoder supports a maximum input voltage range of 0.75 V; therefore, an attenuation of one-half is needed for most input signals with a peak-to-peak variation of 1.5 V. The nominal parallel termination before the input to the device is recommended to be 75  $\Omega$ . See the application diagram in [Figure 6-1](#) for the recommended configuration. The two analog input ports can be connected as follows:

- Two selectable composite video inputs, or
- One S-video input

An internal clamping circuit restores the sync-tip of the ac-coupled video signal to a fixed dc level.

The programmable gain amplifier (PGA) and the automatic gain control (AGC) algorithm work together to make sure that the input signal is amplified sufficiently to ensure the proper input range for the ADC.

The ADC has nine bits of resolution and runs at a nominal speed of 27 MHz. The clock input for the ADC comes from the horizontal PLL.

### 3.2 Composite Processing Block Diagram

The composite processing block processes NTSC/PAL/SECAM signals into the YCbCr color space. [Figure 3-1](#) shows the basic architecture of this processing block.

[Figure 3-1](#) shows the luminance/chrominance (Y/C) separation process in the TVP5151 decoder. The composite video is multiplied by subcarrier signals in the quadrature modulator to generate the color difference signals Cb and Cr. Cb and Cr are then low pass (LP) filtered to achieve the desired bandwidth and to reduce crosstalk.

An adaptive four-line comb filter separates CbCr from Y. Chrominance is remodulated through another quadrature modulator and subtracted from the line-delayed composite video to generate luminance. Brightness, hue, saturation, and sharpness (using the peaking filter) are programmable via I<sup>2</sup>C.

The Y/C separation is bypassed for S-video input. For S-video, the remodulation path is disabled.

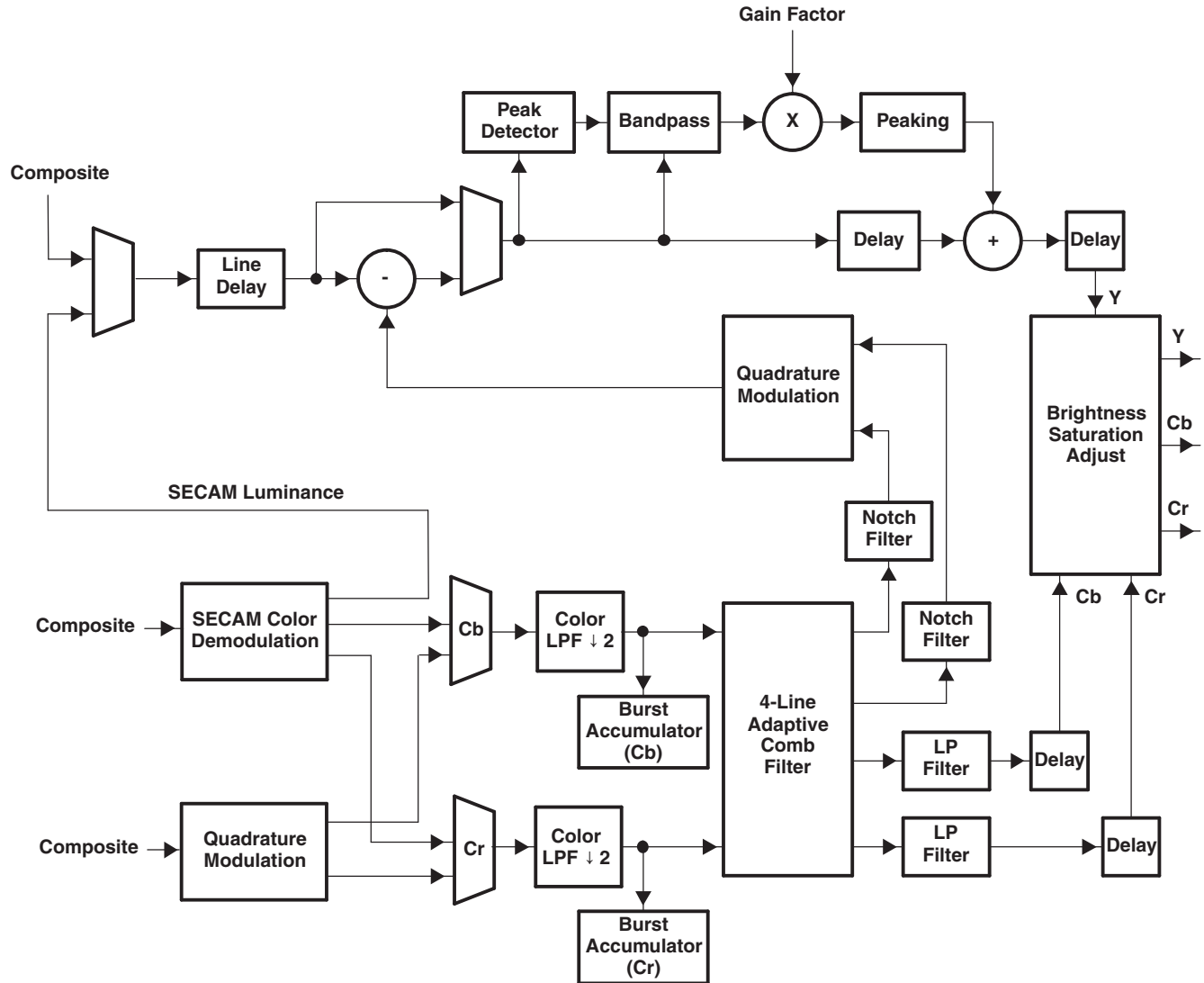

Figure 3-1. Composite Processing Block Diagram (Comb/Trap Filter Bypassed for SECAM)

### 3.3 Adaptive Comb Filtering

The four-line comb filter can be selectively bypassed in the luminance or chrominance path. If the comb filter is bypassed in the luminance path, then chrominance trap filters are used which are shown in [Figure 3-2](#) and [Figure 3-3](#). TI's patented adaptive four-line comb filter algorithm reduces artifacts such as hanging dots at color boundaries and detects and properly handles false colors in high-frequency luminance images such as a multiburst pattern or circle pattern.

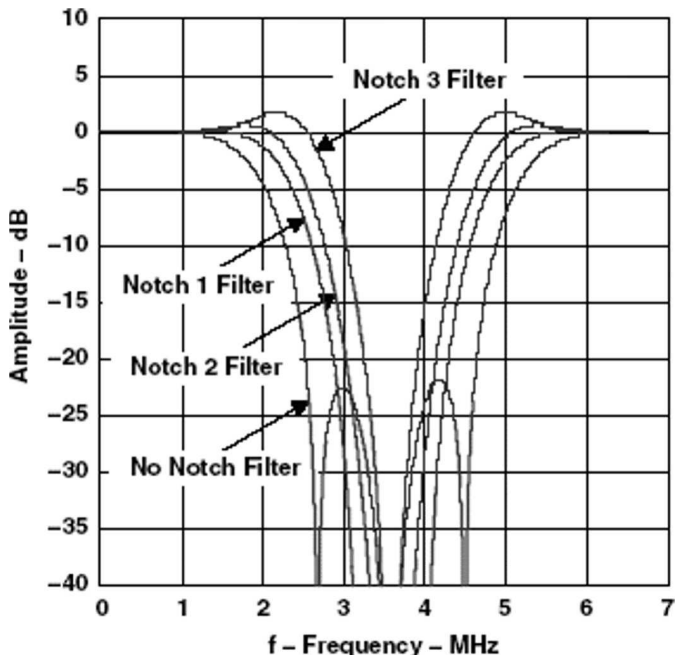

Figure 3-2. Chrominance Trap Filter Frequency Response, NTSC ITU-R BT.601 Sampling

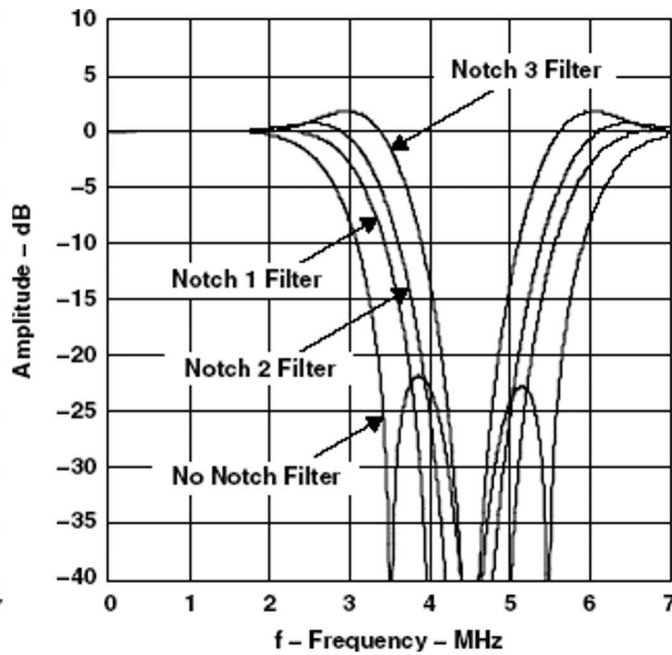

Figure 3-3. Chrominance Trap Filter Frequency Response, PAL ITU-R BT.601 Sampling

### 3.4 Color Low-Pass Filter

In some applications, it is desirable to limit the Cb/Cr bandwidth to avoid crosstalk. This is especially true in case of video signals that have asymmetrical Cb/Cr sidebands. The color LP filters provided limit the bandwidth of the Cb/Cr signals.

Color LP filters are needed when the comb filtering turns off, due to extreme color transitions in the input image. See Section 3.21.25, Chrominance Control #2 Register, for the response of these filters. The filters have three options that allow three different frequency responses based on the color frequency characteristics of the input video as shown in Figure 3-4.

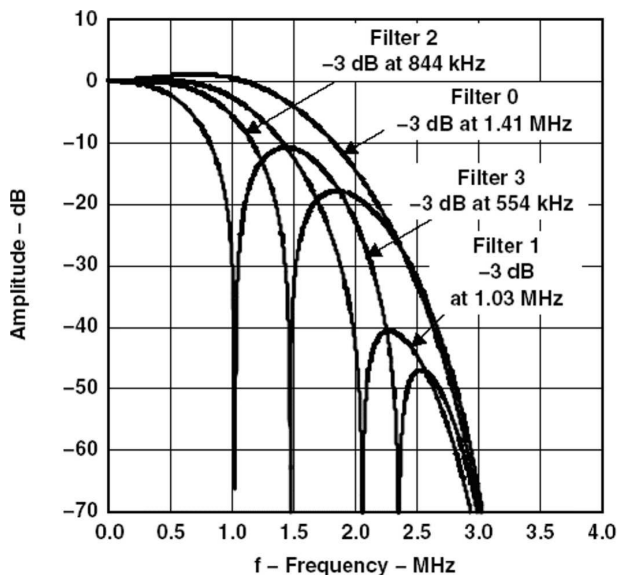

Figure 3-4. Color Low-Pass Filter with Filter Characteristics, NTSC/PAL ITU-R BT.601 Sampling

### 3.5 Luminance Processing

The luminance component is derived from the composite signal by subtracting the remodulated chrominance information. A line delay exists in this path to compensate for the line delay in the adaptive comb filter in the color processing chain. The luminance information is then fed into the peaking circuit, which enhances the high frequency components of the signal, thus improving sharpness.

### 3.6 Chrominance Processing

For NTSC/PAL formats, the color processing begins with a quadrature demodulator. The Cb/Cr signals then pass through the gain control stage for chrominance saturation adjustment. An adaptive comb filter is applied to the demodulated signals to separate chrominance and eliminate cross-chrominance artifacts. An automatic color killer circuit is also included in this block. The color killer suppresses the chrominance processing when the burst amplitude falls below a programmable threshold (see I<sup>2</sup>C subaddress 06h). The SECAM standard is similar to PAL except for the modulation of color which is FM instead of QAM.

### 3.7 Timing Processor

The timing processor is a combination of hardware and software running in the internal microprocessor that serves to control horizontal lock to the input sync pulse edge, AGC and offset adjustment in the analog front end, vertical sync detection, and Macrovision detection.

### 3.8 VBI Data Processor (VDP)

The TVP5151 VDP slices various data services such as teletext (WST, NABTS), closed captioning (CC), wide screen signaling (WSS), etc. These services are acquired by programming the VDP to enable standards in the VBI. The results are stored in a FIFO and/or registers. The teletext results are stored only in a FIFO. [Table 3-1](#) lists a summary of the types of VBI data supported according to the video standard. It supports ITU-R BT. 601 sampling for each.

**Table 3-1. Data Types Supported by VDP**

LINE MODE REGISTER (D0h–FCh) BITS [3:0]	NAME	DESCRIPTION
0000b	WST SECAM	Teletext, SECAM
0001b	WST PAL B	Teletext, PAL, System B
0010b	WST PAL C	Teletext, PAL, System C
0011b	WST, NTSC B	Teletext, NTSC, System B
0100b	NABTS, NTSC C	Teletext, NTSC, System C
0101b	NABTS, NTSC D	Teletext, NTSC, System D (Japan)
0110b	CC, PAL	Closed caption PAL
0111b	CC, NTSC	Closed caption NTSC
1000b	WSS/CGMS-A	Wide-screen signaling/Copy Generation Management System-Analog, PAL
1001b	WSS/CGMS-A	Wide-screen signaling/Copy Generation Management System-Analog, NTSC
1010b	VITC, PAL	Vertical interval timecode, PAL
1011b	VITC, NTSC	Vertical interval timecode, NTSC
1100b	VPS, PAL	Video program system, PAL
1101b	Gemstar 2x Custom 1	Electronic program guide
1110b	Reserved	Reserved
1111b	Active Video	Active video/full field

At power-up the host interface is required to program the VDP-configuration RAM (VDP-CRAM) contents with the lookup table (see [Section 3.21.64](#)). This is done through port address C3h. Each read from or write to this address auto increments an internal counter to the next RAM location. To access the VDP-CRAM, the line mode registers (D0h to FCh) must be programmed with FFh to avoid a conflict with the internal microprocessor and the VDP in both writing and reading. Full field mode must also be disabled.

Available VBI lines are from line 6 to line 27 of both field 1 and field 2. Each line can be any VBI mode.

Output data is available either through the VBI-FIFO (B0h) or through dedicated registers at 90h to AFh, both of which are available through the I<sup>2</sup>C port.

### 3.9 VBI FIFO and Ancillary Data in Video Stream

Sliced VBI data can be output as ancillary data in the video stream in the ITU-R BT.656 mode. VBI data is output during the horizontal blanking period following the line from which the data was retrieved. [Table 3-2](#) shows the header format and sequence of the ancillary data inserted into the video stream. This format is also used to store any VBI data into the FIFO. The size of FIFO is 512 bytes. Therefore, the FIFO can store up to 11 lines of teletext data with the NTSC NABTS standard.

**Table 3-2. Ancillary Data Format and Sequence**

BYTE NO.	D7 (MSB)	D6	D5	D4	D3	D2	D1	D0 (LSB)	DESCRIPTION	
0	0	0	0	0	0	0	0	0	Ancillary data preamble	
1	1	1	1	1	1	1	1	1		
2	1	1	1	1	1	1	1	1		
3	NEP	EP	0	1	0	DID2	DID1	DID0	Data ID (DID)	
4	NEP	EP	F5	F4	F3	F2	F1	F0	Secondary data ID (SDID)	
5	NEP	EP	N5	N4	N3	N2	N1	N0	Number of 32-bit data (NN)	
6	Video line [7:0]								Internal data ID0 (IDID0)	
7	0	0	0	Data error	Match 1	Match 2	Video line [9:8]		Internal data ID1 (IDID1)	
8	1. Data								Data byte	First word
9	2. Data								Data byte	
10	3. Data								Data byte	
11	4. Data								Data byte	
...	...								...	N <sup>th</sup> word
	m-1. Data								Data byte	
	m. Data								Data byte	
	RSVD		CS[5:0]						Check sum	N <sup>th</sup> word
4(N+2)-1	1	0	0	0	0	0	0	0	Fill byte	

EP: Even parity for D0–D5

NEP: Negated even parity

DID: 91h: Sliced data of VBI lines of first field

53h: Sliced data of line 24 to end of first field

55h: Sliced data of VBI lines of second field

97h: Sliced data of line 24 to end of second field

SDID: This field holds the data format taken from the line mode register of the corresponding line.

NN: Number of Dwords beginning with byte 8 through 4(N+2). This value is the number of Dwords where each Dword is 4 bytes.

IDID0: Transaction video line number [7:0]

- IDID1: Bit 0/1 = Transaction video line number [9:8]  
 Bit 2 = Match 2 flag  
 Bit 3 = Match 1 flag  
 Bit 4 = 1 if an error was detected in the EDC block; 0 if not
- CS: Sum of D0–D7 of DID through last data byte.
- Fill byte: Fill bytes make a multiple of 4 bytes from byte 0 to last fill byte.

### 3.10 Raw Video Data Output

The TVP5151 decoder can output raw A/D video data at 2x sampling rate for external VBI slicing. This is transmitted as an ancillary data block during the active horizontal portion of the line and during vertical blanking.

### 3.11 Output Formatter

The YCbCr digital output can be programmed as 8-bit 4:2:2 or 8-bit ITU-R BT.656 parallel interface standard.

**Table 3-3. Summary of Line Frequencies, Data Rates, and Pixel Counts**

STANDARDS (ITU-R BT.601)	PIXELS PER LINE	ACTIVE PIXELS PER LINE	LINES PER FRAME	PIXEL FREQUENCY (MHz)	COLOR SUB-CARRIER FREQUENCY (MHz)	HORIZONTAL LINE RATE (kHz)
NTSC-J, M	858	720	525	13.5	3.579545	15.73426
NTSC-4.43	858	720	525	13.5	4.43361875	15.73426
PAL-M	858	720	525	13.5	3.57561149	15.73426
PAL-B, D, G, H, I	864	720	625	13.5	4.43361875	15.625
PAL-N	864	720	625	13.5	4.43361875	15.625
PAL-Nc	864	720	625	13.5	3.58205625	15.625
SECAM	864	720	625	13.5	4.40625/4.25	15.625

### 3.12 Synchronization Signals

External (discrete) syncs are provided via the following signals (see [Figure 3-5](#) and [Figure 3-6](#)):

- VSYNC (vertical sync)
- FID/VLK (field indicator or vertical lock indicator)
- INTREQ/GPCL/VBLK (general-purpose output or vertical blanking indicator)
- PALI/HLK (PAL switch indicator or horizontal lock indicator)
- HSYNC (horizontal sync)
- AVID (active video indicator) (if set as output)

VSYNC, FID, PALI, and VBLK are software set and programmable to the SCLK pixel count. This allows any possible alignment to the internal pixel count and line count. The default settings for a 525-/625-line video output are given as an example.

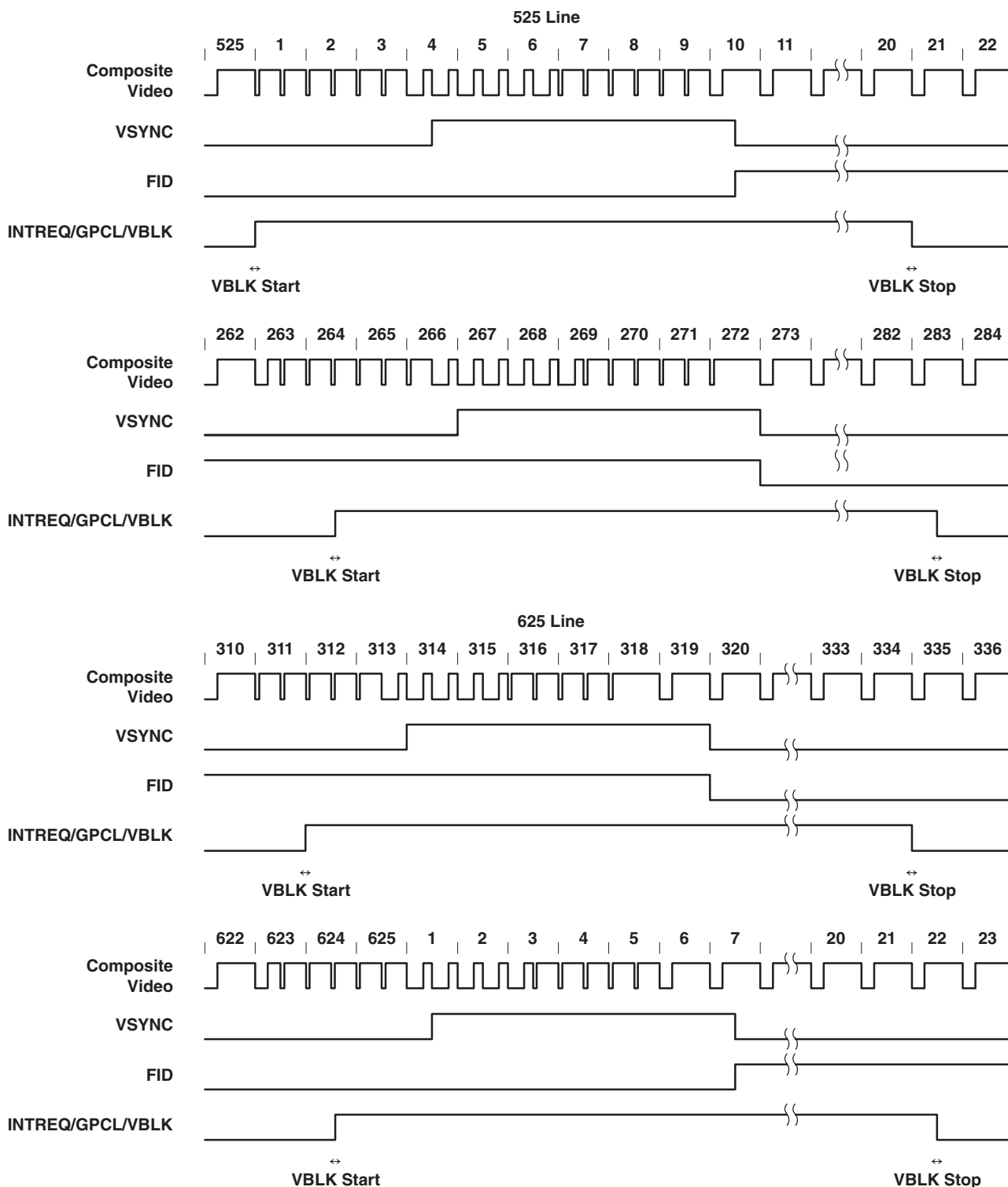

A. Line numbering conforms to ITU-R BT.470 and ITU-R BT.1700.

**Figure 3-5. 8-Bit 4:2:2, Timing With 2× Pixel Clock (SCLK) Reference**

ITU-R BT.656 Timing

NTSC 601	1436	1437	1438	1439	1440	1441	...	1455	1456	...	1583	1584	...	1711	1712	1713	1714	1715	0	1	2	3
PAL 601	1436	1437	1438	1439	1440	1441		1459	1460		1587	1588		1723	1724	1725	1726	1727	0	1	2	3
SECAM	1436	1437	1438	1439	1440	1441	...	1479	1480	...	1607	1608	...	1719	1720	1721	1722	1723	1724	1725	1726	1727
ITU 656 Datastream	Cb 359	Y 718	Cr 359	Y 719	FF	00		10	80		10	80		10	FF	00	00	XX	Cb 0	Y 0	Cr 0	Y 1

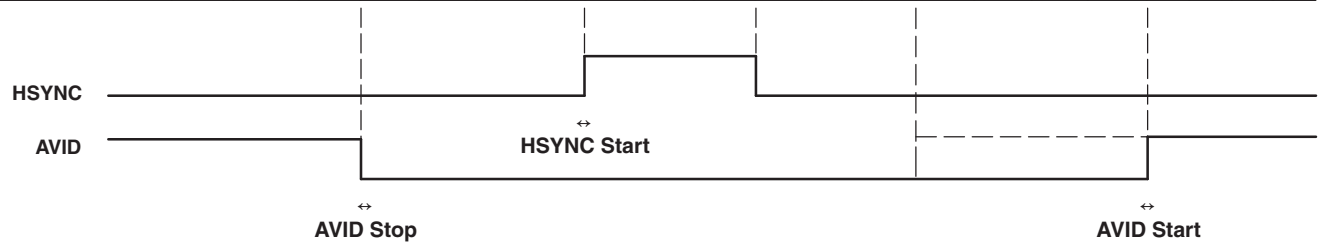

A. AVID rising edge occurs four SCLK cycles early when in the ITU-R BT.656 output mode.

**Figure 3-6. Horizontal Synchronization Signals**

**3.13 Active Video (AVID) Cropping**

The AVID output signal provides a means to qualify and crop active video both horizontally and vertically. The horizontal start and stop position of the AVID signal is controlled using registers 11h-12h and 13h-14h, respectively. These registers also control the horizontal position of the embedded sync SAV/EAV codes.

AVID vertical timing is controlled by the VBLK start and stop registers at addresses 18h and 19h. These VBLK registers have no effect on the embedded vertical sync code timing. [Figure 3-7](#) shows an AVID application.

**NOTE**

The above settings alter AVID output timing, but the video output data is not forced to black level outside of the AVID interval.



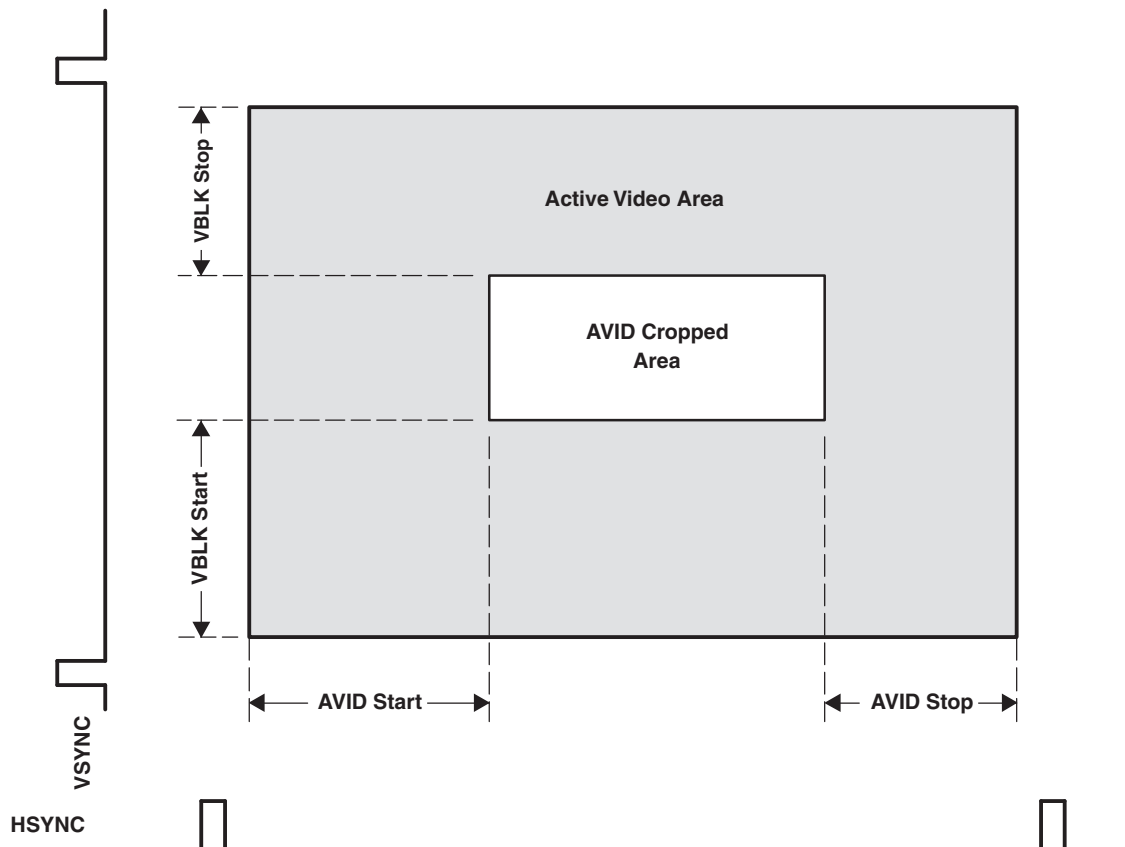

Figure 3-7. AVID Application

### 3.14 Embedded Syncs

Standards with embedded syncs insert SAV and EAV codes into the datastream at the beginning and end of horizontal blanking. These codes contain the V and F bits that also define vertical timing. F and V change on EAV. Table 3-4 gives the format of the SAV and EAV codes.

H equals 1 always indicates EAV. H equals 0 always indicates SAV. The alignment of V and F to the line and field counter varies depending on the standard. See ITU-R BT.656 for more information on embedded syncs.

The P bits are protection bits:

$$P3 = V \text{ xor } H$$

$$P2 = F \text{ xor } H$$

$$P1 = F \text{ xor } V$$

$$P0 = F \text{ xor } V \text{ xor } H$$

Table 3-4. EAV and SAV Sequence

	8-BIT DATA							
	D7 (MSB)	D6	D5	D4	D3	D2	D1	D0
Preamble	1	1	1	1	1	1	1	1
Preamble	0	0	0	0	0	0	0	0
Preamble	0	0	0	0	0	0	0	0
Status word	1	F	V	H	P3	P2	P1	P0

### 3.15 I<sup>2</sup>C Host Interface

The I<sup>2</sup>C standard consists of two signals, serial input/output data line (SDA) and input/output clock line (SCL), which carry information between the devices connected to the bus. A third signal (I2CSEL) is used for slave address selection. Although the I<sup>2</sup>C system can be multimastered, the TVP5151 decoder functions only as a slave device.

Both SDA and SCL must be connected to a positive supply voltage via a pullup resistor. When the bus is free, both lines are high. The slave address select terminal (I2CSEL) enables the use of two TVP5151 decoders tied to the same I<sup>2</sup>C bus. At power up, the status of the I2CSEL is polled. Depending on the write and read addresses to be used for the TVP5151 decoder, it can either be pulled low or high through a resistor. This terminal is multiplexed with YOUT7 and hence must not be tied directly to ground or IO\_DVDD. [Table 3-6](#) summarizes the terminal functions of the I<sup>2</sup>C-mode host interface.

**Table 3-5. Write Address Selection**

I2CSEL	WRITE ADDRESS
0	B8h
1	BAh

**Table 3-6. I<sup>2</sup>C Terminal Description**

SIGNAL	TYPE	DESCRIPTION
I2CSEL (YOUT7)	I	Slave address selection
SCL	I/O (open drain)	Input/output clock line
SDA	I/O (open drain)	Input/output data line

Data transfer rate on the bus is up to 400 kbit/s. The number of interfaces connected to the bus is dependent on the bus capacitance limit of 400 pF. The data on the SDA line must be stable during the high period of the SCL except for start and stop conditions. The high or low state of the data line can only change with the clock signal on the SCL line being low. A high-to-low transition on the SDA line while the SCL is high indicates an I<sup>2</sup>C start condition. A low-to-high transition on the SDA line while the SCL is high indicates an I<sup>2</sup>C stop condition.

Every byte placed on the SDA must be eight bits long. The number of bytes which can be transferred is unrestricted. Each byte must be followed by an acknowledge bit. The acknowledge-related clock pulse is generated by the I<sup>2</sup>C master.

### 3.15.1 I<sup>2</sup>C Write Operation

Data transfers occur utilizing the following illustrated formats.

An I<sup>2</sup>C master initiates a write operation to the TVP5151 decoder by generating a start condition (S) followed by the TVP5151 I<sup>2</sup>C slave address (see the following illustration), in MSB first bit order, followed by a 0 to indicate a write cycle. After receiving an acknowledge from the TVP5151 decoder, the master presents the subaddress of the register, or the first of a block of registers it wants to write, followed by one or more bytes of data, MSB first. The TVP5151 decoder acknowledges each byte after completion of each transfer. The I<sup>2</sup>C master terminates the write operation by generating a stop condition (P).

<b>Step 1</b>	<b>0</b>							
I <sup>2</sup> C Start (master)	S							
<b>Step 2</b>	<b>7</b>	<b>6</b>	<b>5</b>	<b>4</b>	<b>3</b>	<b>2</b>	<b>1</b>	<b>0</b>
I <sup>2</sup> C slave address (master)	1	0	1	1	1	0	X	0
<b>Step 3</b>	<b>9</b>							
I <sup>2</sup> C Acknowledge (slave)	A							
<b>Step 4</b>	<b>7</b>	<b>6</b>	<b>5</b>	<b>4</b>	<b>3</b>	<b>2</b>	<b>1</b>	<b>0</b>
I <sup>2</sup> C Write register address (master)	Addr	Addr	Addr	Addr	Addr	Addr	Addr	Addr
<b>Step 5</b>	<b>9</b>							
I <sup>2</sup> C Acknowledge (slave)	A							
<b>Step 6</b>	<b>7</b>	<b>6</b>	<b>5</b>	<b>4</b>	<b>3</b>	<b>2</b>	<b>1</b>	<b>0</b>
I <sup>2</sup> C Write data (master)	Data	Data	Data	Data	Data	Data	Data	Data
<b>Step 7<sup>(1)</sup></b>	<b>9</b>							
I <sup>2</sup> C Acknowledge (slave)	A							
<b>Step 8</b>	<b>0</b>							
I <sup>2</sup> C Stop (master)	P							

(1) Repeat steps 6 and 7 until all data have been written.

### 3.15.2 I<sup>2</sup>C Read Operation

The read operation consists of two phases. The first phase is the address phase. In this phase, an I<sup>2</sup>C master initiates a write operation to the TVP5151 decoder by generating a start condition (S) followed by the TVP5151 I<sup>2</sup>C slave address, in MSB first bit order, followed by a 0 to indicate a write cycle. After receiving an acknowledge from the TVP5151 decoder, the master presents the subaddress of the register or the first of a block of registers it wants to read. After the cycle is acknowledged, the master terminates the cycle immediately by generating a stop condition (P).

**Table 3-7. Read Address Selection**

I2CSEL	READ ADDRESS
0	B9h
1	BBh

The second phase is the data phase. In this phase, an I<sup>2</sup>C master initiates a read operation to the TVP5151 decoder by generating a start condition followed by the TVP5151 I<sup>2</sup>C slave address (see the following illustration of a read operation), in MSB first bit order, followed by a 1 to indicate a read cycle. After an acknowledge from the TVP5151 decoder, the I<sup>2</sup>C master receives one or more bytes of data from the TVP5151 decoder. The I<sup>2</sup>C master acknowledges the transfer at the end of each byte. After the last data byte desired has been transferred from the TVP5151 decoder to the master, the master generates a not acknowledge followed by a stop.

### 3.15.2.1 Read Phase 1

<b>Step 1</b>	<b>0</b>								
I <sup>2</sup> C Start (master)	S								
<b>Step 2</b>	<b>7</b>	<b>6</b>	<b>5</b>	<b>4</b>	<b>3</b>	<b>2</b>	<b>1</b>	<b>0</b>	
I <sup>2</sup> C slave address (master)	1	0	1	1	1	0	X	0	
<b>Step 3</b>	<b>9</b>								
I <sup>2</sup> C Acknowledge (slave)	A								
<b>Step 4</b>	<b>7</b>	<b>6</b>	<b>5</b>	<b>4</b>	<b>3</b>	<b>2</b>	<b>1</b>	<b>0</b>	
I <sup>2</sup> C Write register address (master)	Addr	Addr	Addr	Addr	Addr	Addr	Addr	Addr	
<b>Step 5</b>	<b>9</b>								
I <sup>2</sup> C Acknowledge (slave)	A								
<b>Step 6</b>	<b>0</b>								
I <sup>2</sup> C Stop (master)	P								

### 3.15.2.2 Read Phase 2

<b>Step 7</b>	<b>0</b>								
I <sup>2</sup> C Start (master)	S								
<b>Step 8</b>	<b>7</b>	<b>6</b>	<b>5</b>	<b>4</b>	<b>3</b>	<b>2</b>	<b>1</b>	<b>0</b>	
I <sup>2</sup> C slave address (master)	1	0	1	1	1	0	X	1	
<b>Step 9</b>	<b>9</b>								
I <sup>2</sup> C Acknowledge (slave)	A								
<b>Step 10</b>	<b>7</b>	<b>6</b>	<b>5</b>	<b>4</b>	<b>3</b>	<b>2</b>	<b>1</b>	<b>0</b>	
I <sup>2</sup> C Read data (slave)	Data	Data	Data	Data	Data	Data	Data	Data	
<b>Step 11<sup>(1)</sup></b>	<b>9</b>								
I <sup>2</sup> C Not Acknowledge (master)	$\bar{A}$								
<b>Step 12</b>	<b>0</b>								
I <sup>2</sup> C Stop (master)	P								

(1) Repeat steps 10 and 11 for all bytes read. Master does not acknowledge the last read data received.

### 3.15.2.3 I<sup>2</sup>C Timing Requirements

The TVP5151 decoder requires delays in the I<sup>2</sup>C accesses to accommodate its internal processor's timing. In accordance with I<sup>2</sup>C specifications, the TVP5151 decoder holds the I<sup>2</sup>C clock line (SCL) low to indicate the wait period to the I<sup>2</sup>C master. If the I<sup>2</sup>C master is not designed to check for the I<sup>2</sup>C clock line held-low condition, then the maximum delays must always be inserted where required. These delays are of variable length; maximum delays are indicated in the following diagram:

Normal register writing addresses 00h to 8Fh (addresses 90h to FFh do not require delays).



The 64-μs delay is for all registers that do not require a reinitialization. Delays may be more for some registers.

### 3.16 Clock Circuits

An internal line-locked PLL generates the system and pixel clocks. A 27.000-MHz clock is required to drive the PLL. This may be input to the TVP5151 decoder on terminal 5 (XTAL1), or a crystal of 27.000-MHz fundamental resonant frequency may be connected across terminals 5 and 6 (XTAL2). Figure 3-8 shows the reference clock configurations. For the example crystal circuit shown (a parallel-resonant crystal with 27.000-MHz fundamental frequency), the external capacitors must have the following relationship:

$$C_{L1} = C_{L2} = 2C_L - C_{STRAY}$$

where  $C_{STRAY}$  is the terminal capacitance with respect to ground, and  $C_L$  is the crystal load capacitance specified by the crystal manufacturer.

Figure 3-8 shows the reference clock configurations.

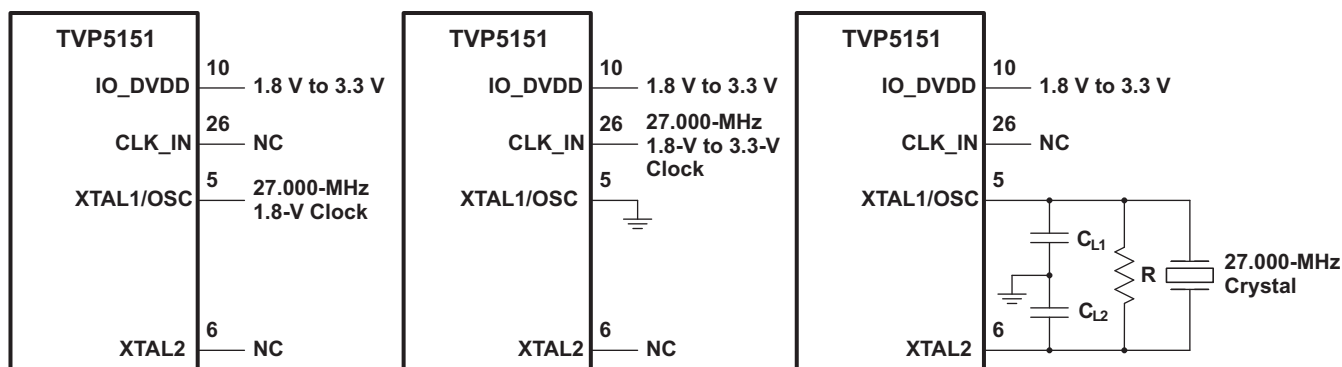

NOTE: The resistor (R) in parallel with the crystal is recommended to support a wide range of crystal types. A 100-kΩ resistor may be used for most crystal types.

Figure 3-8. Reference Clock Configurations

An alternate method to supply an external source with a 1.8-V to 3.3-V peak-to-peak level is to pull pin 5 (XTAL1/OSC) low and connect a 1.8-V to 3.3-V external oscillator clock source to pin 26, AVID/CLK\_IN, depending on what IO\_DVDD supply voltage is used.

Clock source frequency should have an accuracy of ±50 ppm (max).

### 3.17 Genlock Control (GLCO) and RTC

A Genlock control function is provided to support a standard video encoder to synchronize its internal color oscillator for properly reproduced color with unstable timebase sources such as VCRs.

The frequency control word of the internal color subcarrier digitally tuned oscillator (DTO) and the subcarrier phase reset bit are transmitted via terminal 23 (GLCO). The frequency control word is a 23-bit binary number. The frequency of the DTO can be calculated from the following equation:

$$f_{dto} = (f_{ctrl}/2^{23}) \times f_{sclk}$$

where  $f_{dto}$  is the frequency of the DTO,  $f_{ctrl}$  is the 23-bit DTO frequency control, and  $f_{sclk}$  is the frequency of the SCLK.

#### 3.17.1 GLCO Interface

A write of 1 to bit 4 of the chrominance control register at I<sup>2</sup>C subaddress 1Ah causes the subcarrier DTO phase reset bit to be sent on the next scan line on GLCO. The active-low reset bit occurs seven SCLKs after the transmission of the last bit of DTO frequency control. Upon the transmission of the reset bit, the phase of the TVP5151 internal subcarrier DTO is reset to zero.

A Genlock slave device can be connected to the GLCO terminal and uses the information on GLCO to synchronize its internal color phase DTO to achieve clean line and color lock.

Figure 3-9 shows the timing diagram of the GLCO mode.

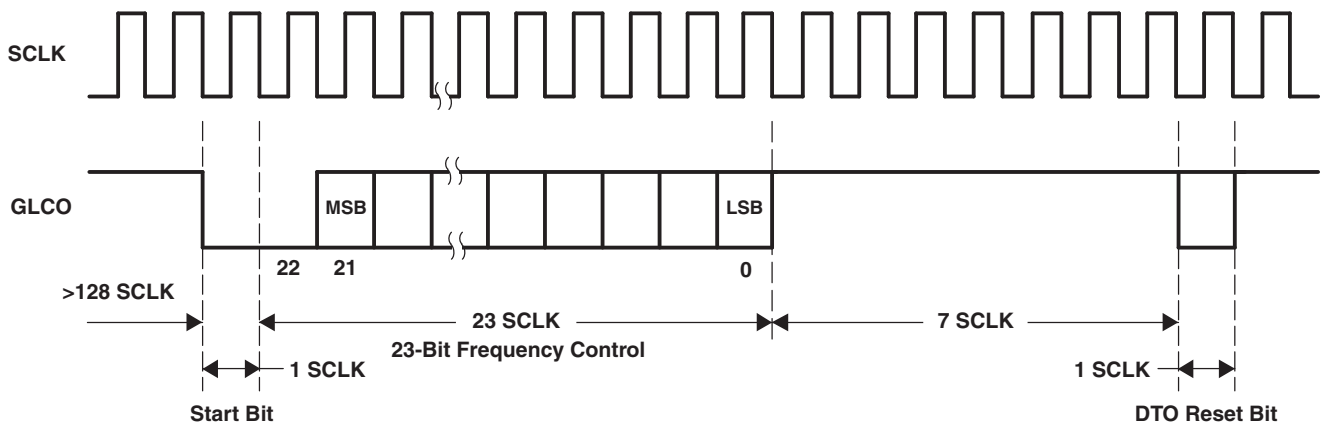

Figure 3-9. GLCO Timing

### 3.17.2 RTC Mode

Figure 3-10 shows the timing diagram of the RTC mode. Clock rate for the RTC mode is four times slower than the GLCO clock rate. For Color PLL frequency control, the upper 22 bits are used. Each frequency control bit is two clock cycles long. The active-low reset bit occurs six CLKs after the transmission of the last bit of PLL frequency control.

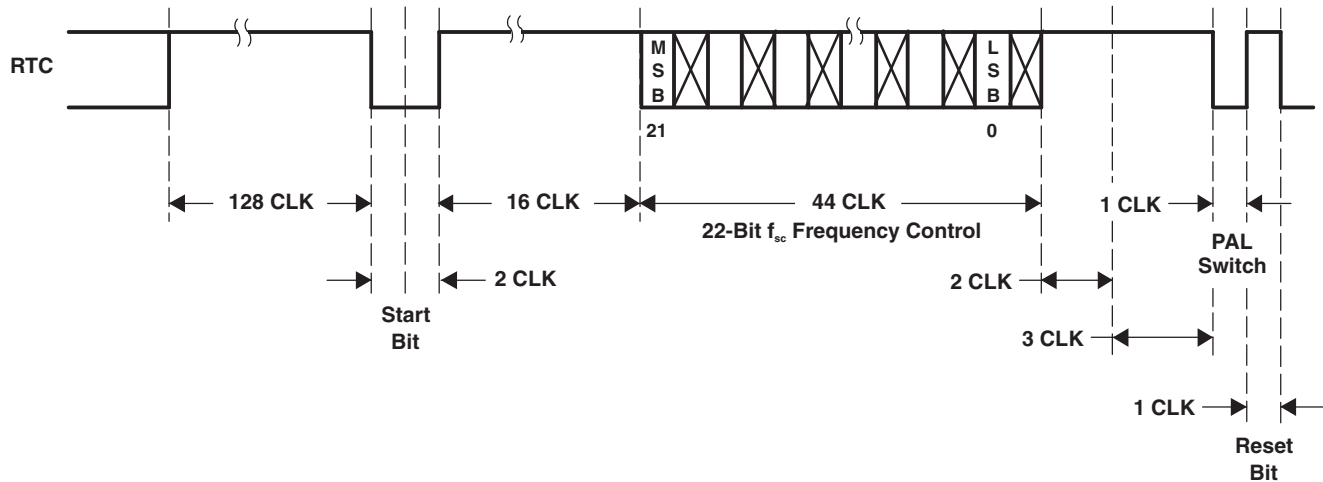

Figure 3-10. RTC Timing

### 3.18 Reset and Power Down

The RESETB and PDN terminals work together to put the TVP5151 decoder into one of the two modes. Table 3-8 shows the configuration.

After power-up, the device is in an unknown state with its outputs undefined, until it receives a RESETB signal as depicted in Figure 3-11. After RESETB is released, outputs SCLK and YOUT0 to YOUT7 are in high-impedance state until TVP5151 is initialized and the outputs are activated.

**NOTE**

I<sup>2</sup>C SCL and SDA signals must not change state until the TVP5151 reset sequence has been completed.

Table 3-8. Reset and Power-Down Modes

PDN	RESETB	CONFIGURATION
0	0	Reserved (unknown state)
0	1	Powers down the decoder
1	0	Resets the decoder
1	1	Normal operation

After RESETB is released, outputs SCLK and YOUT0 to YOUT7 are high-impedance until the chip is initialized and the outputs are activated.

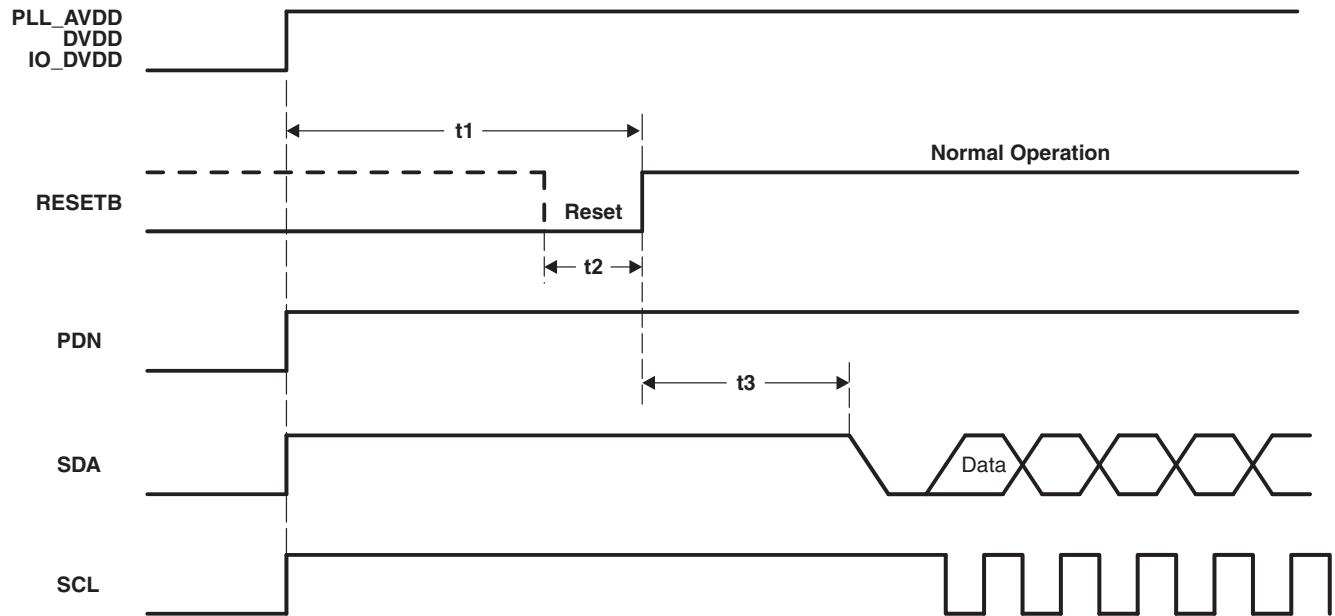

Figure 3-11. Power-On Reset Timing

Table 3-9. Power-On Reset Timing

NO.	PARAMETER	MIN	MAX	UNIT
t1	Delay time between power supplies active and reset	20		ms
t2	RESETB pulse duration	500		ns
t3	Delay time between end of reset to I <sup>2</sup> C active	200		μs



### 3.19 Reset Sequence

Table 3-10 shows the reset sequence of the TVP5151 pins status during reset time and immediately after reset time.

**Table 3-10. Reset Sequence**

PIN DESCRIPTION	DURING RESETB	IMMEDIATELY AFTER RESETB
FID/GLCO, HSYNC, INTREQ/GPCL/VBLK, SCLK, VSYNC/PALI, YOUT[6:0]	High-impedance	High-impedance
AIP1A, AIP1B, AVID/CLK_IN, RESETB, PDN, SDA, SCL, XTAL1/OSC	Input	Input
XTAL2	Output	Output
YOUT7/I2CSEL	Input	High-impedance

TVP5151 is pin compatible with TVP5150/A/AM1, and the following differences should be considered when an upgrade is planned.

- IO\_DVDD supply can be any voltage from 1.8 V to 3.3 V.
- AVID/CLK\_IN is input during RESETB. If this input is used as the clock source, XTAL1/OSC pin must be grounded.

### 3.20 Internal Control Registers

The TVP5151 decoder is initialized and controlled by a set of internal registers that set all device operating parameters. Communication between the external controller and the TVP5151 decoder is through I<sup>2</sup>C. [Table 3-11](#) shows the summary of these registers. The reserved registers must not be written. Reserved bits in the defined registers must be written with zeros, unless otherwise noted. The detailed programming information of each register is described in the following sections.

**Table 3-11. Register Summary**

REGISTER	ADDRESS	DEFAULT	R/W <sup>(1)</sup>
Video input source selection #1	00h	00h	R/W
Analog channel controls	01h	15h	R/W
Operation mode controls	02h	00h	R/W
Miscellaneous controls	03h	00h	R/W
Autoswitch mask	04h	DCh	R/W
Miscellaneous output controls	05h	00h	R/W
Color killer threshold control	06h	10h	R/W
Luminance processing control #1	07h	60h	R/W
Luminance processing control #2	08h	00h	R/W
Brightness control	09h	80h	R/W
Color saturation control	0Ah	80h	R/W
Hue control	0Bh	00h	R/W
Reserved	0Ch		
Outputs and data rates select	0Dh	47h	R/W
Luminance processing control #3	0Eh	00h	R/W
Configuration shared pins	0Fh	00h	R/W
Reserved	10h		
Active video cropping start pixel MSB	11h	00h	R/W
Active video cropping start pixel LSB	12h	00h	R/W
Active video cropping stop pixel MSB	13h	00h	R/W
Active video cropping stop pixel LSB	14h	00h	R/W
Genlock and RTC	15h	01h	R/W
Horizontal sync start	16h	80h	R/W
Reserved	17h		
Vertical blanking start	18h	00h	R/W
Vertical blanking stop	19h	00h	R/W
Chrominance control #1	1Ah	0Ch	R/W
Chrominance control #2	1Bh	14h	R/W
Interrupt reset register B	1Ch	00h	R/W
Interrupt enable register B	1Dh	00h	R/W
Interrupt configuration register B	1Eh	00h	R/W
Reserved	1Fh-20h		
Indirect Register Data	21h-22h	00h	R/W
Indirect Register Address	23h	00h	R/W
Indirect Register Read/Write Strobe	24h	00h	R/W
Reserved	25h-27h		
Video standard	28h	00h	R/W
Reserved	29h-2Bh		
Cb gain factor	2Ch		R

(1) R = Read only, W = Write only, R/W = Read and write

**Table 3-11. Register Summary (continued)**

REGISTER	ADDRESS	DEFAULT	R/W <sup>(1)</sup>
Cr gain factor	2Dh		R
Macrovision on counter	2Eh	0Fh	R/W
Macrovision off counter	2Fh	01h	R/W
656 revision select	30h	00h	R/W
Reserved	31h–7Dh		
Patch Write Address	7Eh	00h	R/W <sup>(2)</sup>
Patch Code Execute	7Fh	00h	R/W <sup>(2)</sup>
Device ID MSB	80h	51h	R
Device ID LSB	81h	51h	R
ROM version	82h	04h	R
RAM version	83h	00h	R
Vertical line count MSB	84h		R
Vertical line count LSB	85h		R
Interrupt status register B	86h		R
Interrupt active register B	87h		R
Status register #1	88h		R
Status register #2	89h		R
Status register #3	8Ah		R
Status register #4	8Bh		R
Status register #5	8Ch		R
Reserved	8Dh		
Patch Read Address	8Eh	00h	R/W <sup>(2)</sup>
Reserved	8Fh		
Closed caption data	90h–93h		R
WSS data	94h–99h		R
VPS data	9Ah–A6h		R
VITC data	A7h–AFh		R
VBI FIFO read data	B0h		R
Teletext filter and mask 1	B1h–B5h	00h	R/W
Teletext filter and mask 2	B6h–BAh	00h	R/W
Teletext filter control	BBh	00h	R/W
Reserved	BCh–BFh		
Interrupt status register A	C0h	00h	R/W
Interrupt enable register A	C1h	00h	R/W
Interrupt configuration register A	C2h	04h	R/W
VDP configuration RAM data	C3h	DCh	R/W
VDP configuration RAM address low byte	C4h	0Fh	R/W
VDP configuration RAM address high byte	C5h	00h	R/W
VDP status	C6h		R
FIFO word count	C7h		R
FIFO interrupt threshold	C8h	80h	R/W
FIFO reset	C9h	00h	W
Line number interrupt	CAh	00h	R/W
Pixel alignment LSB	CBh	4Eh	R/W
Pixel alignment HSB	CCh	00h	R/W
FIFO output control	CDh	01h	R/W

(2) These registers are used for firmware patch code and should not be written to or read from during normal operation.

**Table 3-11. Register Summary (continued)**

REGISTER	ADDRESS	DEFAULT	R/W <sup>(1)</sup>
Reserved	CEh		
Full field enable	CFh	00h	R/W
Line mode	D0h D1h–FBh	00h FFh	R/W
Full field mode	FCh	7Fh	R/W
Reserved	FDh–FFh		

## 3.21 Register Definitions

### 3.21.1 Video Input Source Selection #1 Register

Address 00h  
Default 00h

7	6	5	4	3	2	1	0
Reserved				Black output	Reserved	Channel 1 source selection	S-video selection

Channel 1 source selection

0 = AIP1A selected (default)

1 = AIP1B selected

**Table 3-12. Analog Channel and Video Mode Selection**

	INPUT(S) SELECTED	ADDRESS 00	
		BIT 1	BIT 0
Composite	AIP1A (default)	0	0
	AIP1B	1	0
S-Video	AIP1A (luminance), AIP1B (chrominance)	x	1

Black output

0 = Normal operation (default)

1 = Force black screen output (outputs synchronized)

a. Forced to 10h in normal mode

b. Forced to 01h in extended mode

### 3.21.2 Analog Channel Controls Register

Address 01h  
Default 15h

7	6	5	4	3	2	1	0
Reserved			1	0	1	Automatic gain control	

Automatic gain control (AGC)

00 = AGC disabled (fixed gain value)

01 = AGC enabled (default)

10 = Reserved

11 = AGC frozen to the previously set value

### 3.21.3 Operation Mode Controls Register

Address 02h  
Default 00h

7	6	5	4	3	2	1	0
Reserved	Color burst reference enable	TV/VCR mode		Composite peak disable	Color subcarrier PLL frozen	Luminance peak disable	Power-down mode

#### Color burst reference enable

- 0 = Color burst reference for AGC disabled (default)
- 1 = Color burst reference for AGC enabled (not recommended)

#### TV/VCR mode

- 00 = Automatic mode determined by the internal detection circuit (default)
- 01 = Reserved
- 10 = VCR (nonstandard video) mode
- 11 = TV (standard video) mode

With automatic detection enabled, unstable or nonstandard syncs on the input video forces the detector into the VCR mode. This turns off the comb filters and turns on the chrominance trap filter.

#### Composite peak disable

- 0 = Composite peak protection enabled (default)
- 1 = Composite peak protection disabled

#### Color subcarrier PLL frozen

- 0 = Color subcarrier PLL increments by the internally generated phase increment (default). GLCO pin outputs the frequency increment.
- 1 = Color subcarrier PLL stops operating. GLCO pin outputs the frozen frequency increment.

#### Luminance peak disable

- 0 = Luminance peak processing enabled (default)
- 1 = Luminance peak processing disabled

#### Power-down mode

- 0 = Normal operation (default)
- 1 = Power-down mode. A/Ds are turned off and internal clocks are reduced to minimum.

### 3.21.4 Miscellaneous Controls Register

Address 03h  
Default 00h

7	6	5	4	3	2	1	0
VBLK/GPCL select	GPCL logic level	INTREQ/GPCL/VBLK output enable	Lock status (HVLK)	YCbCr output enable (TVPOE)	HSYNC, VSYNC/PALI, AVID, FID/GLCO output enable	Vertical blanking on/off	Clock output enable

VBLK/GPCL function select (affects INTREQ/GPCL/VBLK output only if bit 1 of I2C register 0Fh is set to 1)

- 0 = GPCL (default)
- 1 = VBLK

GPCL logic level (affects INTREQ/GPCL/VBLK output only if bit 7 is set to 0 and bit 5 is set to 1)

- 0 = GPCL is set to logic 0 (default)
- 1 = GPCL is set to logic 1

INTREQ/GPCL/VBLK output enable

- 0 = Output disabled (default)
- 1 = Output enabled (recommended)

Note: The INTREQ/GPCL/VBLK output (pin 27) must never be left floating. An external 10-k $\Omega$  pulldown resistor is required when the INTREQ/GPCL/VBLK output is disabled (bit 5 of I<sup>2</sup>C register 03h is set to 0).

Lock status (HVLK) (configured along with register 0Fh, see [Figure 3-12](#) for the relationship between the configuration shared pins)

- 0 = Terminal VSYNC/PALI outputs the PAL indicator (PALI) signal and terminal FID/GLCO outputs the field ID (FID) signal (default) (if terminals are configured to output PALI and FID in register 0Fh).
  - 1 = Terminal VSYNC/PALI outputs the horizontal lock indicator (HLK) and terminal FID outputs the vertical lock indicator (VLK) (if terminals are configured to output PALI and FID in register 0Fh).
- These are additional functions that are provided for ease of use.

YCbCr output enable

- 0 = YOUT[7:0] high impedance (default)
- 1 = YOUT[7:0] active

Note: YOUT7 must be pulled high or low for device I<sup>2</sup>C address select.

HSYNC, VSYNC/PALI, active video indicator (AVID), and FID/GLCO output enables

- 0 = HSYNC, VSYNC/PALI, AVID, and FID/GLCO are high-impedance (default).
- 1 = HSYNC, VSYNC/PALI, AVID, and FID/GLCO are active.

Note: This control bit has no effect on the FID/GLCO output when it is programmed to output the GLCO signal (see bit 3 of address 0Fh). When the GLCO signal is selected, the FID/GLCO output is always active.

## Vertical blanking on/off

0 = Vertical blanking (VBLK) off (default)

1 = Vertical blanking (VBLK) on

## Clock output enable

0 = SCLK output is high impedance (default)

1 = SCLK output is enabled

Note: To achieve lowest power consumption, outputs placed in the high-impedance state should not be left floating. A 10-k $\Omega$  pull-down resistor is recommended if not driven externally.

Note: When enabling the outputs, ensure the clock output is not accidentally disabled.

**Table 3-13. Digital Output Control<sup>(1)</sup>**

REGISTER 03h, BIT 3 (TVPOE)	REGISTER C2h, BIT 2 (VDPOE)	YCbCr OUTPUT	NOTES
0	X	High impedance	After both YCbCr output enable bits are programmed
X	0	High impedance	After both YCbCr output enable bits are programmed
1	1	Active	After both YCbCr output enable bits are programmed

(1) VDPOE default is 1, and TVPOE default is 0.



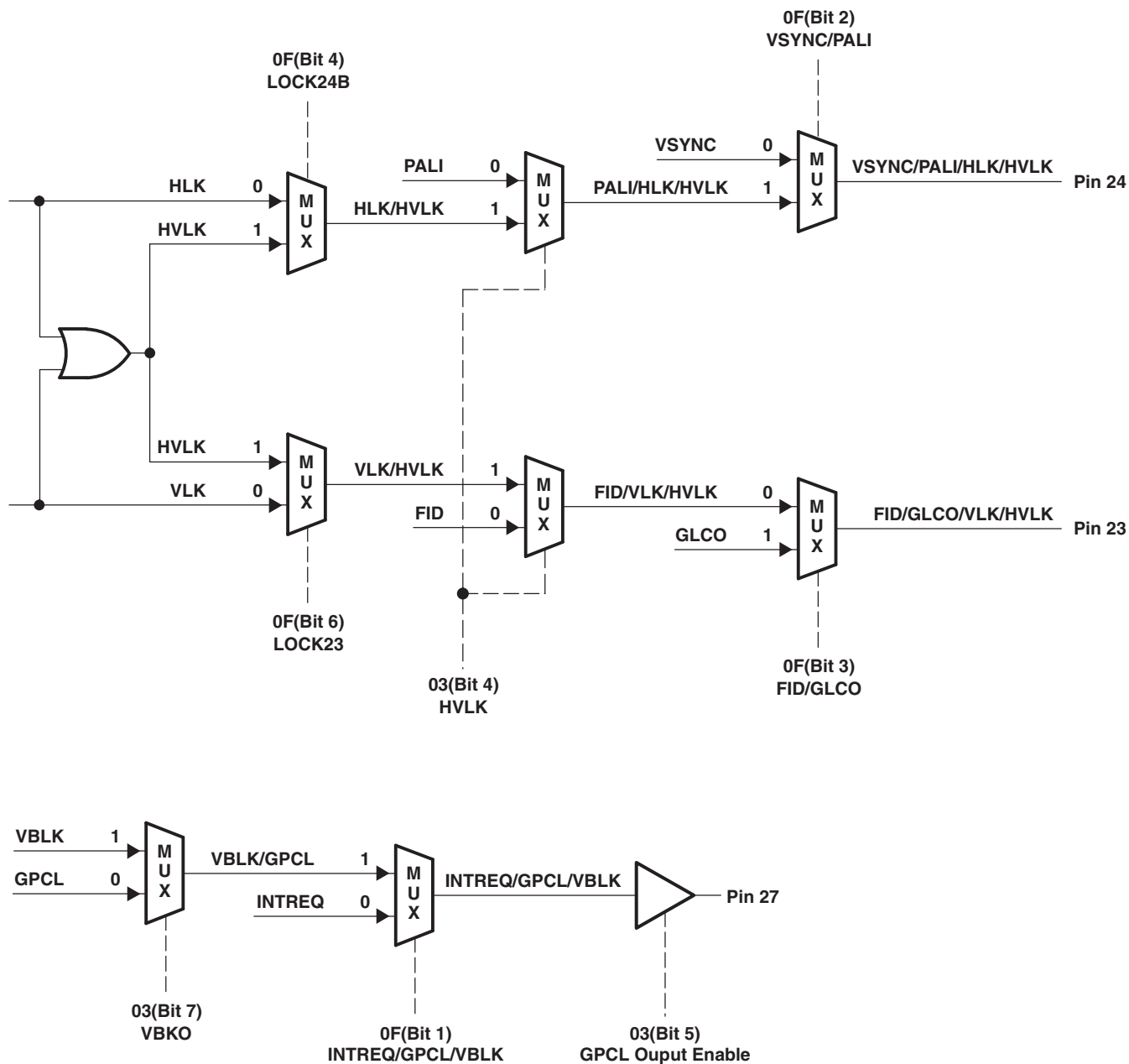

Figure 3-12. Configuration Shared Pins

**NOTE**

Also see the configuration shared pins register at subaddress 0Fh.

### 3.21.5 Autoswitch Mask Register

Address 04h  
Default DCh

7	6	5	4	3	2	1	0
Reserved		SEC_OFF	N4.43_OFF	PALN_OFF	PALM_OFF	Reserved	

#### N4.43\_OFF

0 = NTSC4.43 is unmasked from the autoswitch process. Autoswitch does switch to NTSC4.43.

1 = NTSC4.43 is masked from the autoswitch process. Autoswitch does not switch to NTSC4.43 (default).

#### PALN\_OFF

0 = PAL-N is unmasked from the autoswitch process. Autoswitch does switch to PAL-N.

1 = PAL-N is masked from the autoswitch process. Autoswitch does not switch to PAL-N (default).

#### PALM\_OFF

0 = PAL-M is unmasked from the autoswitch process. Autoswitch does switch to PAL-M.

1 = PAL-M is masked from the autoswitch process. Autoswitch does not switch to PAL-M (default).

#### SEC\_OFF

0 = SECAM is unmasked from the autoswitch process. Autoswitch does switch to SECAM (default).

1 = SECAM is masked from the autoswitch process. Autoswitch does not switch to SECAM.

### 3.21.6 Miscellaneous Output Controls Register

Address 05h  
Default 00h

7	6	5	4	3	2	1	0
Reserved						AVID/CLK_IN function select	Reserved

#### AVID/CLK\_IN function select

0 = CLK\_IN (default)

1 = AVID

### 3.21.7 Color Killer Threshold Control Register

Address 06h  
Default 10h

7	6	5	4	3	2	1	0
Reserved	Automatic color killer		Color killer threshold				

#### Automatic color killer

00 = Automatic mode (default)

01 = Reserved

10 = Color killer enabled, CbCr terminals forced to a zero color state

11 = Color killer disabled

#### Color killer threshold

11111 = –30 dB (minimum)

10000 = –24 dB (default)

00000 = –18 dB (maximum)

### 3.21.8 Luminance Processing Control #1 Register

Address 07h  
Default 60h

7	6	5	4	3	2	1	0
2× luminance output enable	Pedestal not present	Disable raw header	Luminance bypass enabled during vertical blanking	Luminance signal delay with respect to chrominance signal			

#### 2× luminance output enable

- 0 = Output depends on bit 4, luminance bypass enabled during vertical blanking (default).
- 1 = Outputs 2x luminance samples during the entire frame. This bit takes precedence over bit 4.

#### Pedestal not present

- 0 = 7.5 IRE pedestal is present on the analog video input signal.
- 1 = Pedestal is not present on the analog video input signal (default).

#### Disable raw header

- 0 = Insert 656 ancillary headers for raw data
- 1 = Disable 656 ancillary headers and instead force dummy ones (40h) (default)

#### Luminance bypass enabled during vertical blanking

- 0 = Disabled. If bit 7, 2× luminance output enable, is 0, normal luminance processing occurs and YCbCr samples are output during the entire frame (default).
- 1 = Enabled. If bit 7, 2× luminance output enable, is 0, normal luminance processing occurs and YCbCr samples are output during VACTIVE and 2× luminance samples are output during VBLK. Luminance bypass occurs for the duration of the vertical blanking as defined by registers 18h and 19h.

Luminance bypass occurs for the duration of the vertical blanking as defined by registers 18h and 19h.

Luminance signal delay with respect to chrominance signal in pixel clock increments (range –8 to +7 pixel clocks)

- 1111 = –8 pixel clocks delay
- 1011 = –4 pixel clocks delay
- 1000 = –1 pixel clocks delay
- 0000 = 0 pixel clocks delay (default)
- 0011 = +3 pixel clocks delay
- 0111 = +7 pixel clocks delay

### 3.21.9 Luminance Processing Control #2 Register

Address 08h  
Default 00h

7	6	5	4	3	2	1	0
Reserved	Luminance filter select	Reserved		Peaking gain		Mac AGC control	

#### Luminance filter select

- 0 = Luminance comb filter enabled (default)
- 1 = Luminance chrominance trap filter enabled

#### Peaking gain (sharpness)

- 00 = 0 (default)
- 01 = 0.5
- 10 = 1
- 11 = 2

#### Information on peaking frequency:

- ITU-R BT.601 sampling rate: all standards
- Peaking center frequency is 2.6 MHz.

#### Mac AGC control

- 00 = Auto mode
- 01 = Auto mode
- 10 = Force Macrovision AGC pulse detection off
- 11 = Force Macrovision AGC pulse detection on

### 3.21.10 Brightness Control Register

Address 09h  
Default 80h

7	6	5	4	3	2	1	0
Brightness[7:0]							

Brightness[7:0]: This register works for CVBS and S-Video luminance.

- 1111 1111 = 255 (bright)
- 1000 0000 = 128 (default)
- 0000 0000 = 0 (dark)

The output black level relative to the nominal black level (64 out of 1024) as a function of the Brightness[7:0] setting is as follows:

$$\text{Black Level} = \text{nominal\_black\_level} + (\text{Brightness}[7:0] - 128)$$

### 3.21.11 Color Saturation Control Register

Address      0Ah  
 Default      80h

7	6	5	4	3	2	1	0
Saturation[7:0]							

Saturation[7:0]: This register works for CVBS and S-Video chrominance.

1111 1111 = 255 (maximum)

1000 0000 = 128 (default)

0000 0000 = 0 (no color)

The total chrominance gain relative to the nominal chrominance gain as a function of the Saturation[7:0] setting is as follows:

Chrominance Gain = nominal\_chrominance\_gain × (Saturation[7:0] / 128)

### 3.21.12 Hue Control Register

Address      0Bh  
 Default      00h

7	6	5	4	3	2	1	0
Hue control							

Hue control (does not apply to SECAM)

0111 1111 = +180 degrees

0000 0000 = 0 degrees (default)

1000 0000 = –180 degrees

### 3.21.13 Outputs and Data Rates Select Register

Address 0Dh  
Default 47h

7	6	5	4	3	2	1	0
Reserved	YCbCr output code range	CbCr code format	YCbCr data path bypass		YCbCr output format		

#### YCbCr output code range

0 = ITU-R BT.601 coding range (Y ranges from 16 to 235. U and V range from 16 to 240)

1 = Extended coding range (Y, U, and V range from 1 to 254) (default)

#### CbCr code format

0 = Offset binary code (2s complement + 128) (default)

1 = Straight binary code (2s complement)

#### YCbCr data path bypass

00 = Normal operation (default)

01 = Decimation filter output connects directly to the YCbCr output pins. This data is similar to the digitized composite data, but the HBLANK area is replaced with ITU-R BT.656 digital blanking.

10 = Digitized composite (or digitized S-video luminance). A/D output connects directly to YCbCr output pins.

11 = Reserved

#### YCbCr output format

000 = 8-bit 4:2:2 YCbCr with discrete sync output

001 = Reserved

010 = Reserved

011 = Reserved

100 = Reserved

101 = Reserved

110 = Reserved

111 = 8-bit ITU-R BT.656 interface with embedded sync output (default)

### 3.21.14 Luminance Processing Control #3 Register

Address 0Eh  
Default 00h

7	6	5	4	3	2	1	0
Reserved						Luminance trap filter select	

Luminance filter stop band bandwidth (MHz)

- 00 = No notch (default)
- 01 = Notch 1
- 10 = Notch 2
- 11 = Notch 3

Luminance filter select [1:0] selects one of the four chrominance trap (notch) filters to produce luminance signal by removing the chrominance signal from the composite video signal. The stopband of the chrominance trap filter is centered at the chrominance subcarrier frequency with stopband bandwidth controlled by the two control bits. See the following table for the stopband bandwidths. The WCF bit is controlled in the chrominance control #2 register, see [Section 3.21.25](#).

WCF	FILTER SELECT	NTSC/PAL/SECAM ITU-R BT.601
0	00	1.2244
	01	0.8782
	10	0.7297
	11	0.4986
1	00	1.4170
	01	1.0303
	10	0.8438
	11	0.5537

### 3.21.15 Configuration Shared Pins Register

Address 0Fh  
Default 00h

7	6	5	4	3	2	1	0
Reserved	LOCK23	Reserved	LOCK24B	FID/GLCO	VSYNC/PALI	INTREQ/ GPCL/VBLK	Reserved, must be set to 0

LOCK23 (pin 23) function select

- 0 = FID (default, if bit 3 is selected to output FID)
- 1 = Lock indicator (indicates whether the device is locked vertically)

LOCK24B (pin 24) function select

- 0 = PALI (default, if bit 2 is selected to output PALI)
- 1 = Lock indicator (indicates whether the device is locked horizontally)

FID/GLCO (pin 23) function select (also see register 03h for enhanced functionality)

- 0 = FID (default)
- 1 = GLCO

VSYNC/PALI (pin 24) function select (also see register 03h for enhanced functionality)

- 0 = VSYNC (default)
- 1 = PALI

INTREQ/GPCL/VBLK (pin 27) function select

- 0 = INTREQ (default)
- 1 = GPCL or VBLK depending on bit 7 of register 03h

See [Figure 3-12](#) for the relationship between the configuration shared pins.

### 3.21.16 Active Video Cropping Start Pixel MSB Register

Address 11h  
Default 00h

7	6	5	4	3	2	1	0
AVID start pixel MSB [9:2]							

Active video cropping start pixel MSB [9:2], set this register first before setting register 12h. The TVP5151 decoder updates the AVID start values only when register 12h is written to. This start pixel value is relative to the default values of the AVID start pixel.



### 3.21.17 Active Video Cropping Start Pixel LSB Register

Address 12h  
Default 00h

7	6	5	4	3	2	1	0
Reserved					AVID active	AVID start pixel LSB [1:0]	

AVID active

0 = AVID out active in VBLK (default)

1 = AVID out inactive in VBLK

Active video cropping start pixel LSB [1:0]: The TVP5151 decoder updates the AVID start values only when this register is written to.

AVID start [9:0] (combined registers 11h and 12h)

01 1111 1111 = 511

00 0000 0001 = 1

00 0000 0000 = 0 (default)

11 1111 1111 = -1

10 0000 0000 = -512

### 3.21.18 Active Video Cropping Stop Pixel MSB Register

Address 13h  
Default 00h

7	6	5	4	3	2	1	0
AVID stop pixel MSB [9:2]							

Active video cropping stop pixel MSB [9:2], set this register first before setting the register 14h. The TVP5151 decoder updates the AVID stop values only when register 14h is written to. This stop pixel value is relative to the default values of the AVID stop pixel.

### 3.21.19 Active Video Cropping Stop Pixel LSB Register

Address 14h  
Default 00h

7	6	5	4	3	2	1	0
Reserved						AVID stop pixel LSB	

Active video cropping stop pixel LSB [1:0]: The number of pixels of active video must be an even number. The TVP5151 decoder updates the AVID stop values only when this register is written to.

AVID stop [9:0] (combined registers 13h and 14h)

01 1111 1111 = 511

00 0000 0001 = 1

00 0000 0000 = 0 (default) (see [Figure 3-6](#) and [Figure 3-7](#))

11 1111 1111 = -1

10 0000 0000 = -512

### 3.21.20 Genlock and RTC Register

Address 15h  
Default 01h

7	6	5	4	3	2	1	0
Reserved		F/V bit control		Reserved		GLCO/RTC	

F/V bit control

BIT 5	BIT 4	NUMBER OF LINES	F BIT	V BIT
0	0	Standard	ITU-R BT.656	ITU-R BT.656
		Nonstandard even	Force to 1	Switch at field boundary
		Nonstandard odd	Toggles	Switch at field boundary
0	1	Standard	ITU-R BT.656	ITU-R BT.656
		Nonstandard	Toggles	Switch at field boundary
1	0	Standard	ITU-R BT.656	ITU-R BT.656
		Nonstandard	Pulse mode	Switch at field boundary
1	1	Illegal		

GLCO/RTC. The following table shows the different modes.

BIT 2	BIT 1	BIT 0	GENLOCK/RTC MODE
0	X	0	GLCO
0	X	1	RTC output mode 0 (default)
1	X	0	GLCO
1	X	1	RTC output mode 1

All other values are reserved.

Figure 3-9 shows the timing of GLCO, and Figure 3-10 shows the timing of RTC.

### 3.21.21 Horizontal Sync Start Register

Address 16h  
Default 80h

7	6	5	4	3	2	1	0
HSYNC start							

Horizontal sync (HSYNC) start

- 1111 1111 =  $-127 \times 4$  pixel clocks
- 1111 1110 =  $-126 \times 4$  pixel clocks
- 1000 0001 =  $-1 \times 4$  pixel clocks
- 1000 0000 = 0 pixel clocks (default)
- 0111 1111 =  $1 \times 4$  pixel clocks
- 0111 1110 =  $2 \times 4$  pixel clocks
- 0000 0000 =  $128 \times 4$  pixel clocks

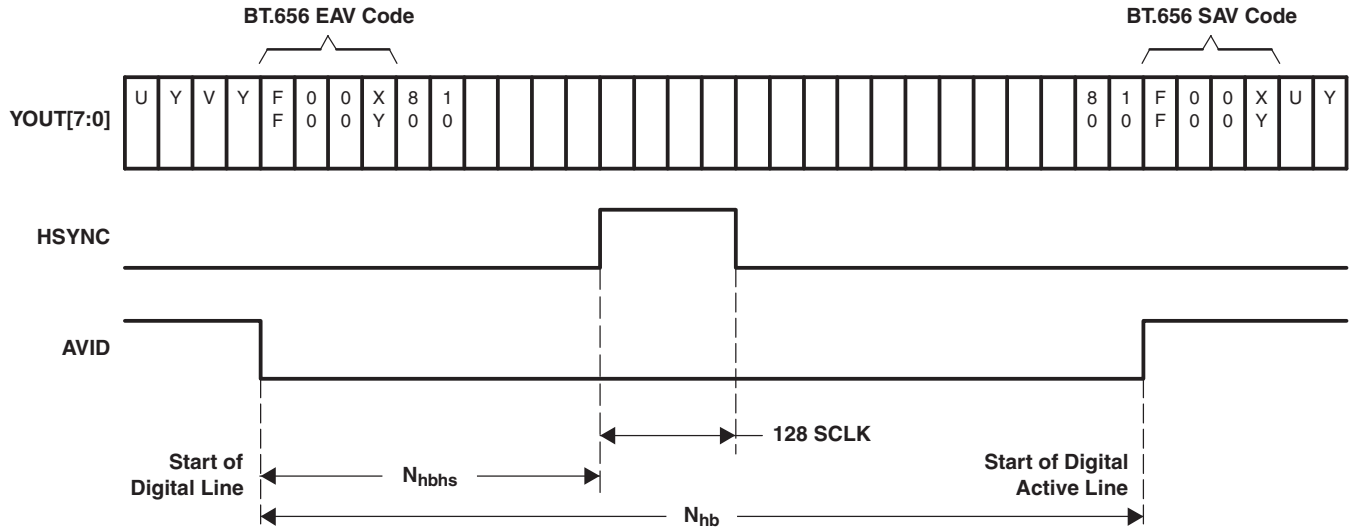

Figure 3-13. Horizontal Sync

Table 3-14. Clock Delays (SCLKs)

STANDARD	N <sub>hbhs</sub>	N <sub>hb</sub>
NTSC	28	272
PAL	32	284
SECAM	32	284

Detailed timing information is also available in [Section 3.12](#).

### 3.21.22 Vertical Blanking Start Register

Address 18h

Default 00h

7	6	5	4	3	2	1	0
Vertical blanking start							

Vertical blanking (VBLK) start

0111 1111 = 127 lines after start of vertical blanking interval

0000 0001 = 1 line after start of vertical blanking interval

0000 0000 = Same time as start of vertical blanking interval (default) (see [Figure 3-5](#))

1111 1111 = 1 line before start of vertical blanking interval

1000 0000 = 128 lines before start of vertical blanking interval

Vertical blanking is adjustable with respect to the standard vertical blanking intervals. The setting in this register determines the timing of the INTREQ/GPCL/VBLK signal when it is configured to output vertical blank (see register 03h). The setting in this register also determines the duration of the luminance bypass function (see register 07h).

### 3.21.23 Vertical Blanking Stop Register

Address 19h  
 Default 00h

7	6	5	4	3	2	1	0
Vertical blanking stop							

Vertical blanking (VBLK) stop

- 0111 1111 = 127 lines after stop of vertical blanking interval
- 0000 0001 = 1 line after stop of vertical blanking interval
- 0000 0000 = Same time as stop of vertical blanking interval (default) (see [Figure 3-5](#))
- 1111 1111 = 1 line before stop of vertical blanking interval
- 1000 0000 = 128 lines before stop of vertical blanking interval

Vertical blanking is adjustable with respect to the standard vertical blanking intervals. The setting in this register determines the timing of the INTREQ/GPCL/VBLK signal when it is configured to output vertical blank (see register 03h). The setting in this register also determines the duration of the luminance bypass function (see register 07h).

### 3.21.24 Chrominance Control #1 Register

Address 1Ah  
 Default 0Ch

7	6	5	4	3	2	1	0
Reserved			Color PLL reset	Chrominance adaptive comb filter enable (ACE)	Chrominance comb filter enable (CE)	Automatic color gain control	

Color PLL reset

- 0 = Color PLL not reset (default)
- 1 = Color PLL reset

When a 1 is written to this bit, the color PLL phase is reset to zero and the subcarrier PLL phase reset bit is transmitted on terminal 23 (GLCO) on the next line (NTSC or PAL).

Chrominance adaptive comb filter enable (ACE)

- 0 = Disable
- 1 = Enable (default)

Chrominance comb filter enable (CE)

- 0 = Disable
- 1 = Enable (default)

Automatic color gain control (ACGC)

- 00 = ACGC enabled (default)
- 01 = Reserved
- 10 = ACGC disabled
- 11 = ACGC frozen to the previously set value

### 3.21.25 Chrominance Control #2 Register

Address 1Bh  
Default 14h

<b>7</b>	<b>6</b>	<b>5</b>	<b>4</b>	<b>3</b>	<b>2</b>	<b>1</b>	<b>0</b>
Reserved					WCF	Chrominance filter select	

Wideband chrominance filter (WCF)

0 = Disable

1 = Enable (default)

Chrominance low pass filter select

00 = No notch (default)

01 = Notch 1

10 = Notch 2

11 = Notch 3

Chrominance output bandwidth (MHz)

WCF	FILTER SELECT	NTSC/PAL/SECAM ITU-R BT.601
0	00	1.2214
	01	0.8782
	10	0.7297
	11	0.4986
1	00	1.4170
	01	1.0303
	10	0.8438
	11	0.5537

### 3.21.26 Interrupt Reset Register B

Address 1Ch  
Default 00h

7	6	5	4	3	2	1	0
Software initialization reset	Macrovision detect changed reset	Reserved	Field rate changed reset	Line alternation changed reset	Color lock changed reset	H/V lock changed reset	TV/VCR changed reset

Interrupt reset register B is used by the external processor to reset the interrupt status bits in interrupt status register B. Bits loaded with a 1 allow the corresponding interrupt status bit to reset to 0. Bits loaded with a 0 have no effect on the interrupt status bits.

#### Software initialization reset

- 0 = No effect (default)
- 1 = Reset software initialization bit

#### Macrovision detect changed reset

- 0 = No effect (default)
- 1 = Reset Macrovision detect changed bit

#### Field rate changed reset

- 0 = No effect (default)
- 1 = Reset field rate changed bit

#### Line alternation changed reset

- 0 = No effect (default)
- 1 = Reset line alternation changed bit

#### Color lock changed reset

- 0 = No effect (default)
- 1 = Reset color lock changed bit

#### H/V lock changed reset

- 0 = No effect (default)
- 1 = Reset H/V lock changed bit

TV/VCR changed reset [TV/VCR mode is determined by counting the total number of lines/frame. The mode switches to VCR for nonstandard number of lines]

- 0 = No effect (default)
- 1 = Reset TV/VCR changed bit

### 3.21.27 Interrupt Enable Register B

Address 1Dh  
Default 00h

7	6	5	4	3	2	1	0
Software initialization occurred	Macrovision detect changed	Reserved	Field rate changed	Line alternation changed	Color lock changed	H/V lock changed	TV/VCR changed

Interrupt enable register B is used by the external processor to mask unnecessary interrupt sources for interrupt B. Bits loaded with a 1 allow the corresponding interrupt condition to generate an interrupt on the external pin. Conversely, bits loaded with zeros mask the corresponding interrupt condition from generating an interrupt on the external pin. This register only affects the external pin, it does not affect the bits in the interrupt status register. A given condition can set the appropriate bit in the status register and not cause an interrupt on the external pin. To determine if this device is driving the interrupt pin either AND interrupt status register B with interrupt enable register B or check the state of interrupt B in the interrupt B active register.

#### Software initialization occurred

- 0 = Disabled (default)
- 1 = Enabled

#### Macrovision detect changed

- 0 = Disabled (default)
- 1 = Enabled

#### Field rate changed

- 0 = Disabled (default)
- 1 = Enabled

#### Line alternation changed

- 0 = Disabled (default)
- 1 = Enabled

#### Color lock changed

- 0 = Disabled (default)
- 1 = Enabled

#### H/V lock changed

- 0 = Disabled (default)
- 1 = Enabled

#### TV/VCR changed

- 0 = Disabled (default)
- 1 = Enabled

### 3.21.28 Interrupt Configuration Register B

Address 1Eh  
Default 00h

7	6	5	4	3	2	1	0
Reserved							Interrupt polarity B

Interrupt polarity B

0 = Interrupt B is active low (default).

1 = Interrupt B is active high.

Interrupt polarity B must be the same as interrupt polarity A of Interrupt Configuration Register A at Address C2h.

Interrupt Configuration Register B is used to configure the polarity of interrupt B on the external interrupt pin. When the interrupt B is configured for active low, the pin is driven low when active and high impedance when inactive (open-drain). Conversely, when the interrupt B is configured for active high, it is driven high for active and driven low for inactive.

Note: An external pullup resistor (4.7 k $\Omega$  to 10 k $\Omega$ ) is required when the polarity of the external interrupt terminal (pin 27) is configured as active low.

### 3.21.29 Indirect Register Data

Address 21h-22h  
Default 00h

Address	7	6	5	4	3	2	1	0
22h	Data[15:8]							
21h	Data[7:0]							

I<sup>2</sup>C registers 21h and 22h can be used to write data to or read data from indirect registers. See I<sup>2</sup>C registers 23h and 24h.

### 3.21.30 Indirect Register Address

Address 23h  
Default 00h

7	6	5	4	3	2	1	0
ADDR[7:0]							

ADDR[7:0] = LSB of indirect address



### 3.21.31 Indirect Register Read/Write Strobe

Address 24h  
Default 00h

7	6	5	4	3	2	1	0
R/W[7:0]							

This register selects the most significant bits of the indirect register address and performs either an indirect read or write operation. Data will be written from are read to Indirect Register Data registers 21h-22h.

R/W[7:0]:

- 01h = read from 00h-1FFh address bank
- 02h = write to 00h-1FFh address bank
- 03h = read from 200h-3FFh address bank
- 04h = write to 200h-3FFh address bank
- 05h = read from 300h-3FFh address bank
- 06h = write to 300h-3FFh address bank

### 3.21.32 Video Standard Register

Address 28h  
Default 00h

7	6	5	4	3	2	1	0
Reserved				Video standard			

Video standard

- 0000 = Autoswitch mode (default)
- 0001 = Reserved
- 0010 = (M, J) NTSC ITU-R BT.601
- 0011 = Reserved
- 0100 = (B, G, H, I, N) PAL ITU-R BT.601
- 0101 = Reserved
- 0110 = (M) PAL ITU-R BT.601
- 0111 = Reserved
- 1000 = (Combination-N) PAL ITU-R BT.601
- 1001 = Reserved
- 1010 = NTSC 4.43 ITU-R BT.601
- 1011 = Reserved
- 1100 = SECAM ITU-R BT.601

With the autoswitch code running, the application can force the device to operate in a particular video standard mode by writing the appropriate value into this register.

### 3.21.33 Cb Gain Factor Register

Address 2Ch

7	6	5	4	3	2	1	0
Cb gain factor							

This is a read-only register that provides the gain applied to the Cb in the YCbCr data stream.

### 3.21.34 Cr Gain Factor Register

Address 2Dh

7	6	5	4	3	2	1	0
Cr gain factor							

This is a read-only register that provides the gain applied to the Cr in the YCbCr data stream.

### 3.21.35 Macrovision On Counter Register

Address 2Eh

Default 0Fh

7	6	5	4	3	2	1	0
Macrovision on counter							

This register allows the user to determine how many consecutive frames in which the Macrovision AGC pulses are detected before the decoder decides that the Macrovision AGC pulses are present.

### 3.21.36 Macrovision Off Counter Register

Address 2Fh

Default 01h

7	6	5	4	3	2	1	0
Macrovision off counter							

This register allows the user to determine how many consecutive frames in which the Macrovision AGC pulses are not detected before the decoder decides that the Macrovision AGC pulses are not present.

### 3.21.37 656 Revision Select Register

Address 30h

Default 00h

7	6	5	4	3	2	1	0
Reserved							656 revision select

656 revision select

0 = Adheres to ITU-R BT.656.4 and BT.656.5 timing (default)

1 = Adheres to ITU-R BT.656.3 timing

### 3.21.38 Patch Write Address

Address 7Eh  
Default 00h

7	6	5	4	3	2	1	0
R/W[7:0]							

This register is used for downloading firmware patch code. Please refer to the patch load application note for more detail. This register must not be written to or read from during normal operation.

### 3.21.39 Patch Code Execute

Address 7Fh  
Default 00h

7	6	5	4	3	2	1	0
R/W[7:0]							

Writing to this register following a firmware patch load restarts the CPU and initiates execution of the patch code. This register must not be written to or read from during normal operation.

### 3.21.40 MSB of Device ID Register

Address 80h  
Default 51h

7	6	5	4	3	2	1	0
MSB of device ID							

This register identifies the MSB of the device ID. Value = 51h.

### 3.21.41 LSB of Device ID Register

Address 81h  
Default 51h

7	6	5	4	3	2	1	0
LSB of device ID							

This register identifies the LSB of the device ID. Value = 51h.

### 3.21.42 ROM Version Register

Address 82h  
Default 04h

7	6	5	4	3	2	1	0
ROM version [7:0]							

ROM Version [7:0]: This register identifies the ROM code revision number.

### 3.21.43 RAM Version Register

Address 83h  
Default 00h

7	6	5	4	3	2	1	0
RAM version [7:0]							

RAM Version [7:0]: This register identifies the RAM code revision number.

Example:

Patch Release = v01.25  
ROM Version = 01h  
RAM Version = 25h

Note: Use of the latest patch release is highly recommended.

### 3.21.44 Vertical Line Count MSB Register

Address 84h

7	6	5	4	3	2	1	0
Reserved						Vertical line count MSB	

Vertical line count bits [9:8]

### 3.21.45 Vertical Line Count LSB Register

Address 85h

7	6	5	4	3	2	1	0
Vertical line count LSB							

Vertical line count bits [7:0]

Registers 84h and 85h can be read and combined to extract the detected number of lines per frame. This can be used with nonstandard video signals such as a VCR in fast-forward or rewind modes to synchronize the downstream video circuitry.

### 3.21.46 Interrupt Status Register B

Address 86h

7	6	5	4	3	2	1	0
Software initialization	Macrovision detect changed	Reserved	Field rate changed	Line alternation changed	Color lock changed	H/V lock changed	TV/VCR changed

#### Software initialization

- 0 = Software initialization is not ready.
- 1 = Software initialization is ready.

#### Macrovision detect changed

- 0 = Macrovision detect status has not changed.
- 1 = Macrovision detect status has changed.

#### Field rate changed

- 0 = Field rate has not changed.
- 1 = Field rate has changed.

#### Line alternation changed

- 0 = Line alteration has not changed.
- 1 = Line alternation has changed.

#### Color lock changed

- 0 = Color lock status has not changed.
- 1 = Color lock status has changed.

#### H/V lock changed

- 0 = H/V lock status has not changed.
- 1 = H/V lock status has changed.

#### TV/VCR changed

- 0 = TV/VCR status has not changed.
- 1 = TV/VCR status has changed.

Interrupt status register B is polled by the external processor to determine the interrupt source for interrupt B. After an interrupt condition is set, it can be reset by writing to the interrupt reset register B at subaddress 1Ch with a 1 in the appropriate bit.

### 3.21.47 Interrupt Active Register B

Address 87h

7	6	5	4	3	2	1	0
Reserved							Interrupt B

#### Interrupt B

0 = Interrupt B is not active on the external terminal (default).

1 = Interrupt B is active on the external terminal.

The interrupt active register B is polled by the external processor to determine if interrupt B is active.

### 3.21.48 Status Register #1

Address 88h

7	6	5	4	3	2	1	0
Peak white detect status	Line-alternating status	Field rate status	Lost lock detect	Color subcarrier lock status	Vertical sync lock status	Horizontal sync lock status	TV/VCR status

#### Peak white detect status

0 = Peak white is not detected.

1 = Peak white is detected.

#### Line-alternating status

0 = Nonline alternating

1 = Line alternating

#### Field rate status

0 = 60 Hz

1 = 50 Hz

#### Lost lock detect

0 = No lost lock since status register #1 was last read.

1 = Lost lock since status register #1 was last read.

#### Color subcarrier lock status

0 = Color subcarrier is not locked.

1 = Color subcarrier is locked.

#### Vertical sync lock status

0 = Vertical sync is not locked.

1 = Vertical sync is locked.

#### Horizontal sync lock status

0 = Horizontal sync is not locked.

1 = Horizontal sync is locked.

TV/VCR status. TV mode is determined by detecting standard line-to-line variations and specific chrominance SCH phases based on the standard input video format. VCR mode is determined by detecting variations in the chrominance SCH phases compared to the chrominance SCH phases of the standard input video format.

0 = TV

1 = VCR

### 3.21.49 Status Register #2

Address 89h

7	6	5	4	3	2	1	0
Reserved	Weak signal detection	PAL switch polarity	Field sequence status	AGC and offset frozen status	Macrovision detection		

#### Weak signal detection

0 = No weak signal

1 = Weak signal mode

#### PAL switch polarity of first line of odd field

0 = PAL switch is 0.

1 = PAL switch is 1.

#### Field sequence status

0 = Even field

1 = Odd field

#### AGC and offset frozen status

0 = AGC and offset are not frozen.

1 = AGC and offset are frozen.

#### Macrovision detection

000 = No copy protection

001 = AGC process present (Macrovision Type 1 present)

010 = Colorstripe process Type 2 present

011 = AGC process and colorstripe process Type 2 present

100 = Reserved

101 = Reserved

110 = Colorstripe process Type 3 present

111 = AGC process and color stripe process Type 3 present

### 3.21.50 Status Register #3

Address		8Ah					
7	6	5	4	3	2	1	0
Analog gain				Digital gain			

Analog gain: 4-bit front-end AGC analog gain setting

Digital gain: 4 MSBs of 6-bit front-end AGC digital gain setting

The product of the analog and digital gain is as follows:

$$\text{Gain Product} = (1 + 3 \times \text{analog\_gain} / 15) \times (1 + \text{gain\_step} \times \text{digital\_gain} / 4096)$$

Where,

$$0 \leq \text{analog\_gain} \leq 15$$

$$0 \leq \text{digital\_gain} \leq 63$$

The gain\_step setting as a function of the analog\_gain setting is shown in [Table 3-15](#).

**Table 3-15. gain\_step Setting**

analog_gain	gain_step
0	61
1	55
2	48
3	44
4	38
5	33
6	29
7	26
8	24
9	22
10	20
11	19
12	18
13	17
14	16
15	15

### 3.21.51 Status Register #4

Address		8Bh					
7	6	5	4	3	2	1	0
Subcarrier to horizontal (SCH) phase							

SCH (color PLL subcarrier phase at 50% of the falling edge of horizontal sync of line one of odd field; step size 360°/256)

$$0000\ 0000 = 0.00^\circ$$

$$0000\ 0001 = 1.41^\circ$$

$$0000\ 0010 = 2.81^\circ$$

$$1111\ 1110 = 357.2^\circ$$

$$1111\ 1111 = 358.6^\circ$$



### 3.21.52 Status Register #5

Address 8Ch

<b>7</b>	<b>6</b>	<b>5</b>	<b>4</b>	<b>3</b>	<b>2</b>	<b>1</b>	<b>0</b>
Autoswitch mode	Reserved			Video standard			Sampling rate (SR)

This register contains information about the detected video standard at which the device is currently operating. When autoswitch code is running, this register must be tested to determine which video standard has been detected.

Autoswitch mode

0 = Forced video standard

1 = Autoswitch mode

Video standard

VIDEO STANDARD [3:1]			SR	VIDEO STANDARD
BIT 3	BIT 2	BIT 1	BIT 0	
0	0	0	0	Reserved
0	0	0	1	(M, J) NTSC ITU-R BT.601
0	0	1	0	Reserved
0	0	1	1	(B, D, G, H, I, N) PAL ITU-R BT.601
0	1	0	0	Reserved
0	1	0	1	(M) PAL ITU-R BT.601
0	1	1	0	Reserved
0	1	1	1	PAL-Nc ITU-R BT.601
1	0	0	0	Reserved
1	0	0	1	NTSC 4.43 ITU-R BT.601
1	0	1	0	Reserved
1	0	1	1	SECAM ITU-R BT.601

### 3.21.53 Patch Read Address

Address 8Eh

Default 00h

<b>7</b>	<b>6</b>	<b>5</b>	<b>4</b>	<b>3</b>	<b>2</b>	<b>1</b>	<b>0</b>
R/W[7:0]							

This register can be used for patch code read-back. This register must not be written to or read from during normal operation.

### 3.21.54 Closed Caption Data Registers

Address 90h–93h

Address	7	6	5	4	3	2	1	0
90h	Closed caption field 1 byte 1							
91h	Closed caption field 1 byte 2							
92h	Closed caption field 2 byte 1							
93h	Closed caption field 2 byte 2							

These registers contain the closed caption data arranged in bytes per field.

### 3.21.55 WSS/CGMS-A Data Registers

Address 94h–99h

#### NTSC

Address	7	6	5	4	3	2	1	0	BYTE
94h			b5	b4	b3	b2	b1	b0	WSS field 1 byte 1
95h	b13	b12	b11	b10	b9	b8	b7	b6	WSS field 1 byte 2
96h			b19	b18	b17	b16	b15	b14	WSS field 1 byte 3
97h			b5	b4	b3	b2	b1	b0	WSS field 2 byte 1
98h	b13	b12	b11	b10	b9	b8	b7	b6	WSS field 2 byte 2
99h			b19	b18	b17	b16	b15	b14	WSS field 2 byte 3

These registers contain the wide screen signaling (WSS/CGMS-A) data for NTSC.

For NTSC, the bits are:

Bits 0–1 represent word 0, aspect ratio.

Bits 2–5 represent word 1, header code for word 2.

Bits 6–13 represent word 2, copy control.

Bits 14–19 represent word 3, CRC.

#### PAL/SECAM

Address	7	6	5	4	3	2	1	0	BYTE
94h	b7	b6	b5	b4	b3	b2	b1	b0	WSS field 1 byte 1
95h			b13	b12	b11	b10	b9	b8	WSS field 1 byte 2
96h	Reserved								
97h	b7	b6	b5	b4	b3	b2	b1	b0	WSS field 2 byte 1
98h			b13	b12	b11	b10	b9	b8	WSS field 2 byte 2
99h	Reserved								

For PAL/SECAM, the bits are:

Bits 0–3 represent group 1, aspect ratio.

Bits 4–7 represent group 2, enhanced services.

Bits 8–10 represent group 3, subtitles.

Bits 11–13 represent group 4, others.

### 3.21.56 VPS Data Registers

Address 9Ah–A6h

Address	7	6	5	4	3	2	1	0
9Ah	VPS byte 1							
9Bh	VPS byte 2							
9Ch	VPS byte 3							
9Dh	VPS byte 4							
9Eh	VPS byte 5							
9Fh	VPS byte 6							
A0h	VPS byte 7							
A1h	VPS byte 8							
A2h	VPS byte 9							
A3h	VPS byte 10							
A4h	VPS byte 11							
A5h	VPS byte 12							
A6h	VPS byte 13							

These registers contain the entire VPS data line except the clock run-in code and the start code.

### 3.21.57 VITC Data Registers

Address A7h–AFh

Address	7	6	5	4	3	2	1	0
A7h	VITC byte 1, frame byte 1							
A8h	VITC byte 2, frame byte 2							
A9h	VITC byte 3, seconds byte 1							
AAh	VITC byte 4, seconds byte 2							
ABh	VITC byte 5, minutes byte 1							
ACh	VITC byte 6, minutes byte 2							
ADh	VITC byte 7, hour byte 1							
A Eh	VITC byte 8, hour byte 2							
AFh	VITC byte 9, CRC							

These registers contain the VITC data.

### 3.21.58 VBI FIFO Read Data Register

Address B0h

7	6	5	4	3	2	1	0
FIFO read data							

This address is provided to access VBI data in the FIFO through the host port. All forms of teletext data come directly from the FIFO, while all other forms of VBI data can be programmed to come from the registers or from the FIFO. Current status of the FIFO can be found at address C6h and the number of bytes in the FIFO is located at address C7h. If the host port is to be used to read data from the FIFO, then the host access enable bit at address CDh must be set to 1. The format used for the VBI FIFO is shown in [Section 3.9](#).

### 3.21.59 Teletext Filter and Mask Registers

Address B1h–BAh  
 Default 00h

Address	7	6	5	4	3	2	1	0	
B1h		Filter 1 mask 1					Filter 1 pattern 1		
B2h		Filter 1 mask 2					Filter 1 pattern 2		
B3h		Filter 1 mask 3					Filter 1 pattern 3		
B4h		Filter 1 mask 4					Filter 1 pattern 4		
B5h		Filter 1 mask 5					Filter 1 pattern 5		
B6h		Filter 2 mask 1					Filter 2 pattern 1		
B7h		Filter 2 mask 2					Filter 2 pattern 2		
B8h		Filter 2 mask 3					Filter 2 pattern 3		
B9h		Filter 2 mask 4					Filter 2 pattern 4		
BAh		Filter 2 mask 5					Filter 2 pattern 5		

For an NABTS system, the packet prefix consists of five bytes. Each byte contains four data bits (D[3:0]) interlaced with four Hamming protection bits (H[3:0]):

7	6	5	4	3	2	1	0
D[3]	H[3]	D[2]	H[2]	D[1]	H[1]	D[0]	H[0]

Only the data portion D[3:0] from each byte is applied to a teletext filter function with the corresponding pattern bits P[3:0] and mask bits M[3:0]. Hamming protection bits are ignored by the filter.

For a WST system (PAL or NTSC), the packet prefix consists of two bytes so that two patterns are used. Patterns 3, 4, and 5 are ignored.

The mask bits enable filtering using the corresponding bit in the pattern register. For example, a 1 in the LSB of mask 1 means that the filter module must compare the LSB of nibble 1 in the pattern register to the first data bit on the transaction. If these match, a true result is returned. A 0 in a bit of mask 1 means that the filter module must ignore that data bit of the transaction. If all zeros are programmed in the mask bits, the filter matches all patterns returning a true result (default 00h).

Pattern and mask for each byte and filter are referred as <1,2><P,M><1,2,3,4,5>, where:

- <1,2> identifies the filter 1 or 2
- <P,M> identifies the pattern or mask
- <1,2,3,4,5> identifies the byte number

### 3.21.60 Teletext Filter Control Register

Address      BBh  
 Default      00h

7	6	5	4	3	2	1	0
Reserved			Filter logic		Mode	TTX filter 2 enable	TTX filter 1 enable

Filter logic allows different logic to be applied when combining the decision of filter 1 and filter 2 as follows:

00 = NOR (Default)

01 = NAND

10 = OR

11 = AND

Mode

0 = Teletext WST PAL mode B (2 header bytes) (default)

1 = Teletext NABTS NTSC mode C (5 header bytes)

TTX filter 2 enable

0 = Disabled (default)

1 = Enabled

TTX filter 1 enable

0 = Disabled (default)

1 = Enabled

If the filter matches or if the filter mask is all zeros, a true result is returned.

### 3.21.61 Interrupt Status Register A

Address C0h  
Default 00h

7	6	5	4	3	2	1	0
Lock state interrupt	Lock interrupt	Reserved			FIFO threshold interrupt	Line interrupt	Data interrupt

The interrupt status register A can be polled by the host processor to determine the source of an interrupt. After an interrupt condition is set it can be reset by writing to this register with a 1 in the appropriate bit(s).

#### Lock state interrupt

- 0 = TVP5151 is not locked to the video signal (default).
- 1 = TVP5151 is locked to the video signal.

#### Lock interrupt

- 0 = A transition has not occurred on the lock signal (default).
- 1 = A transition has occurred on the lock signal.

#### FIFO threshold interrupt

- 0 = The amount of data in the FIFO has not yet crossed the threshold programmed at address C8h (default).
- 1 = The amount of data in the FIFO has crossed the threshold programmed at address C8h.

#### Line interrupt

- 0 = The video line number has not yet been reached (default).
- 1 = The video line number programmed in address CAh has occurred.

#### Data interrupt

- 0 = No data is available (default).
- 1 = VBI data is available either in the FIFO or in the VBI data registers.

### 3.21.62 Interrupt Enable Register A

Address C1h  
Default 00h

7	6	5	4	3	2	1	0
Reserved	Lock interrupt enable	Reserved			FIFO threshold interrupt enable	Line interrupt enable	Data interrupt enable

The interrupt enable register A is used by the host processor to mask unnecessary interrupt sources. Bits loaded with a 1 allow the corresponding interrupt condition to generate an interrupt on the external pin. Conversely, bits loaded with a 0 mask the corresponding interrupt condition from generating an interrupt on the external pin. This register only affects the interrupt on the external terminal, it does not affect the bits in interrupt status register A. A given condition can set the appropriate bit in the status register and not cause an interrupt on the external terminal. To determine if this device is driving the interrupt terminal, either perform a logical AND of interrupt status register A with interrupt enable register A, or check the state of the interrupt A bit in the interrupt configuration register at address C2h.

#### Lock interrupt enable

- 0 = Disabled (default)
- 1 = Enabled

#### FIFO threshold interrupt enable

- 0 = Disabled (default)
- 1 = Enabled

#### Line interrupt enable

- 0 = Disabled (default)
- 1 = Enabled

#### Data interrupt enable

- 0 = Disabled (default)
- 1 = Enabled

### 3.21.63 Interrupt Configuration Register A

Address C2h  
Default 04h

7	6	5	4	3	2	1	0
Reserved					YCbCr enable (VDPOE)	Interrupt A	Interrupt polarity A

YCbCr enable (VDPOE)

0 = YCbCr pins are high impedance.

1 = YCbCr pins are active if other conditions are met (default) (see [Table 3-13](#)).

Interrupt A (read only)

0 = Interrupt A is not active on the external pin (default).

1 = Interrupt A is active on the external pin.

Interrupt polarity A must be the same as interrupt polarity B of Interrupt Configuration Register B at Address 1Eh.

Interrupt polarity A

0 = Interrupt A is active low (default).

1 = Interrupt A is active high.

Interrupt configuration register A is used to configure the polarity of the external interrupt terminal. When interrupt A is configured as active low, the terminal is driven low when active and high impedance when inactive (open drain). Conversely, when the terminal is configured as active high, it is driven high when active and driven low when inactive.

Note: An external pullup resistor (4.7 kΩ to 10 kΩ) is required when the polarity of the external interrupt terminal (pin 27) is configured as active low.

### 3.21.64 VDP Configuration RAM Register

Address C3h C4h C5h  
Default DCh 0Fh 00h

Address	7	6	5	4	3	2	1	0
C3h	Configuration data							
C4h	RAM address (7:0)							
C5h	Reserved							RAM address 8

The configuration RAM data is provided to initialize the VDP with initial constants. The configuration RAM is 512 bytes organized as 32 different configurations of 16 bytes each. The first 12 configurations are defined for the current VBI standards. An additional two configurations can be used as a custom programmed mode for unique standards such as Gemstar.

Address C3h is used to read or write to the RAM. The RAM internal address counter is automatically incremented with each transaction. Addresses C5h and C4h make up a 9-bit address to load the internal address counter with a specific start address. This can be used to write a subset of the RAM for only those standards of interest.

#### NOTE

Registers D0h–FBh must all be programmed with FFh before writing or reading the configuration RAM. Full field mode (CFh) must be disabled as well.



The suggested RAM contents are shown in [Table 3-16](#). All values are hexadecimal.

**Table 3-16. VBI Configuration RAM for Signals With Pedestal**

INDEX	ADDRESS	0	1	2	3	4	5	6	7	8	9	A	B	C	D	E	F
WST SECAM	000	AA	AA	FF	FF	E7	2E	20	A6	E4	B4	0E	0	7	0	10	0
WST SECAM	010	AA	AA	FF	FF	E7	2E	20	A6	E4	B4	0E	0	7	0	10	0
WST PAL B	020	AA	AA	FF	FF	27	2E	20	AB	A4	72	10	0	7	0	10	0
WST PAL B	030	AA	AA	FF	FF	27	2E	20	AB	A4	72	10	0	7	0	10	0
WST PAL C	040	AA	AA	FF	FF	E7	2E	20	22	A4	98	0D	0	0	0	10	0
WST PAL C	050	AA	AA	FF	FF	E7	2E	20	22	A4	98	0D	0	0	0	10	0
WST NTSC	060	AA	AA	FF	FF	27	2E	20	23	63	93	0D	0	0	0	10	0
WST NTSC	070	AA	AA	FF	FF	27	2E	20	23	63	93	0D	0	0	0	10	0
NABTS, NTSC	080	AA	AA	FF	FF	E7	2E	20	A2	63	93	0D	0	7	0	15	0
NABTS, NTSC	090	AA	AA	FF	FF	E7	2E	20	A2	63	93	0D	0	7	0	15	0
NABTS, NTSC-J	0A0	AA	AA	FF	FF	A7	2E	20	A3	63	93	0D	0	7	0	10	0
NABTS, NTSC-J	0B0	AA	AA	FF	FF	A7	2E	20	A3	63	93	0D	0	7	0	10	0
CC, PAL/SECAM	0C0	AA	2A	FF	3F	04	51	6E	02	A4	7B	09	0	0	0	27	0
CC, PAL/SECAM	0D0	AA	2A	FF	3F	04	51	6E	02	A4	7B	09	0	0	0	27	0
CC, NTSC	0E0	AA	2A	FF	3F	04	51	6E	02	63	8C	09	0	0	0	27	0
CC, NTSC	0F0	AA	2A	FF	3F	04	51	6E	02	63	8C	09	0	0	0	27	0
WSS/CGMS-A, PAL/SECAM	100	5B	55	C5	FF	0	71	6E	42	A4	CD	0F	0	0	0	3A	0
WSS/CGMS-A, PAL/SECAM	110	5B	55	C5	FF	0	71	6E	42	A4	CD	0F	0	0	0	3A	0
WSS/CGMS-A, NTSC C	120	38	00	3F	00	0	71	6E	43	63	7C	08	0	0	0	39	0
WSS/CGMS-A, NTSC C	130	38	00	3F	00	0	71	6E	43	63	7C	08	0	0	0	39	0
VITC, PAL/SECAM	140	0	0	0	0	0	8F	6D	49	A4	85	08	0	0	0	4C	0
VITC, PAL/SECAM	150	0	0	0	0	0	8F	6D	49	A4	85	08	0	0	0	4C	0
VITC, NTSC	160	0	0	0	0	0	8F	6D	49	63	94	08	0	0	0	4C	0
VITC, NTSC	170	0	0	0	0	0	8F	6D	49	63	94	08	0	0	0	4C	0
VPS, PAL	180	AA	AA	FF	FF	BA	CE	2B	8D	A4	DA	0B	0	7	0	60	0
VPS, PAL	190	AA	AA	FF	FF	BA	CE	2B	8D	A4	DA	0B	0	7	0	60	0
Gemstar 2x Custom 1	1A0	99	99	FF	FF	05	51	6E	05	63	18	13	80	00	00	60	00
Gemstar 2x Custom 1	1B0	Programmable															
Custom 2	1C0	Programmable															
Custom 2	1D0	Programmable															

### 3.21.65 VDP Status Register

Address		C6h					
7	6	5	4	3	2	1	0
FIFO full error	FIFO empty	TTX available	CC field 1 available	CC field 2 available	WSS available	VPS available	VITC available

The VDP status register indicates whether data is available in either the FIFO or data registers, and status information about the FIFO. Reading data from the corresponding register does not clear the status flags automatically. These flags are only reset by writing a 1 to the respective bit. However, bit 6 is updated automatically.

#### FIFO full error

- 0 = No FIFO full error
- 1 = FIFO was full during a write to FIFO.

The FIFO full error flag is set when the current line of VBI data can not enter the FIFO. For example, if the FIFO has only ten bytes left and teletext is the current VBI line, the FIFO full error flag is set, but no data is written because the entire teletext line does not fit. However, if the next VBI line is closed caption requiring only two bytes of data plus the header, this goes into the FIFO, even if the full error flag is set.

#### FIFO empty

- 0 = FIFO is not empty.
- 1 = FIFO is empty.

#### TTX available

- 0 = Teletext data is not available.
- 1 = Teletext data is available.

#### CC field 1 available

- 0 = Closed caption data from field 1 is not available.
- 1 = Closed caption data from field 1 is available.

#### CC field 2 available

- 0 = Closed caption data from field 2 is not available.
- 1 = Closed caption data from field 2 is available.

#### WSS available

- 0 = WSS data is not available.
- 1 = WSS data is available.

#### VPS available

- 0 = VPS data is not available.
- 1 = VPS data is available.

#### VITC available

- 0 = VITC data is not available.
- 1 = VITC data is available.

### 3.21.66 FIFO Word Count Register

Address C7h

7	6	5	4	3	2	1	0
Number of words							

This register provides the number of words in the FIFO. One word equals two bytes.

### 3.21.67 FIFO Interrupt Threshold Register

Address C8h

Default 80h

7	6	5	4	3	2	1	0
Number of words							

This register is programmed to trigger an interrupt when the number of words in the FIFO exceeds this value (default 80h). This interrupt must be enabled at address C1h. One word equals two bytes.

### 3.21.68 FIFO Reset Register

Address C9h

Default 00h

7	6	5	4	3	2	1	0
Any data							

Writing any data to this register resets the FIFO and clears any data present in all VBI read registers.

### 3.21.69 Line Number Interrupt Register

Address CAh

Default 00h

7	6	5	4	3	2	1	0
Field 1 enable	Field 2 enable	Line number					

This register is programmed to trigger an interrupt when the video line number matches this value in bits 5:0. This interrupt must be enabled at address C1h. The value of 0 or 1 does not generate an interrupt.

Field 1 enable

0 = Disabled (default)

1 = Enabled

Field 2 enable

0 = Disabled (default)

1 = Enabled

Line number default is 00h.

### 3.21.70 Pixel Alignment Registers

Address      CBh            CCh  
 Default      4Eh            00h

Address	7	6	5	4	3	2	1	0	
CBh	Switch pixel [7:0]								
CCh	Reserved						Switch pixel [9:8]		

These registers form a 10-bit horizontal pixel position from the falling edge of sync, where the VDP controller initiates the program from one line standard to the next line standard; for example, the previous line of teletext to the next line of closed caption. This value must be set so that the switch occurs after the previous transaction has cleared the delay in the VDP, but early enough to allow the new values to be programmed before the current settings are required.

### 3.21.71 FIFO Output Control Register

Address      CDh  
 Default      01h

7	6	5	4	3	2	1	0
Reserved							Host access enable

This register is programmed to allow I<sup>2</sup>C access to the FIFO or to allow all VDP data to go out the video port as ancillary data.

Host access enable

- 0 = Output FIFO data to the video output YOUT[7:0] as ancillary data
- 1 = Read FIFO data via I2C register B0h (default)

### 3.21.72 Full Field Enable Register

Address      CFh  
 Default      00h

7	6	5	4	3	2	1	0
Reserved							Full field enable

This register enables the full field mode. In this mode, all lines outside the vertical blank area and all lines in the line mode registers programmed with FFh are sliced with the definition of register FCh. Values other than FFh in the line mode registers allow a different slice mode for that particular line.

Full field enable

- 0 = Disable full field mode (default)
- 1 = Enable full field mode

### 3.21.73 Line Mode Registers

Address      D0h              D1h–FBh  
 Default      00h              FFh

Address	7	6	5	4	3	2	1	0
D0								Line 6 Field 1
D1								Line 6 Field 2
D2								Line 7 Field 1
D3								Line 7 Field 2
D4								Line 8 Field 1
D5								Line 8 Field 2
D6								Line 9 Field 1
D7								Line 9 Field 2
D8								Line 10 Field 1
D9								Line 10 Field 2
DA								Line 11 Field 1
DB								Line 11 Field 2
DC								Line 12 Field 1
DD								Line 12 Field 2
DE								Line 13 Field 1
DF								Line 13 Field 2
E0								Line 14 Field 1
E1								Line 14 Field 2
E2								Line 15 Field 1
E3								Line 15 Field 2
E4								Line 16 Field 1
E5								Line 16 Field 2
E6								Line 17 Field 1
E7								Line 17 Field 2
E8								Line 18 Field 1
E9								Line 18 Field 2
EA								Line 19 Field 1
EB								Line 19 Field 2
EC								Line 20 Field 1
ED								Line 20 Field 2
EE								Line 21 Field 1
EF								Line 21 Field 2
F0								Line 22 Field 1
F1								Line 22 Field 2
F2								Line 23 Field 1
F3								Line 23 Field 2
F4								Line 24 Field 1
F5								Line 24 Field 2
F6								Line 25 Field 1
F7								Line 25 Field 2
F8								Line 26 Field 1
F9								Line 26 Field 2
FA								Line 27 Field 1
FB								Line 27 Field 2

These registers program the specific VBI standard at a specific line in the video field.

**Bit 7**

- 0 = Disable filtering of null bytes in closed caption modes
- 1 = Enable filtering of null bytes in closed caption modes (default)

In teletext modes, bit 7 enables the data filter function for that particular line. If it is set to 0, the data filter passes all data on that line.

**Bit 6**

- 0 = Send VBI data to registers only
- 1 = Send VBI data to FIFO and the registers. Teletext data only goes to FIFO (default).

**Bit 5**

- 0 = Allow VBI data with errors in the FIFO
- 1 = Do not allow VBI data with errors in the FIFO (default)

**Bit 4**

- 0 = Do not enable error detection and correction
- 1 = Enable error detection and correction (default)

**Bits [3:0]**

- 0000 = WST SECAM
- 0001 = WST PAL B
- 0010 = WST PAL C
- 0011 = WST NTSC
- 0100 = NABTS NTSC
- 0101 = TTX NTSC-J
- 0110 = CC PAL
- 0111 = CC NTSC
- 1000 = WSS/CGMS-A PAL
- 1001 = WSS/CGMS-A NTSC
- 1010 = VITC PAL
- 1011 = VITC NTSC
- 1100 = VPS PAL
- 1101 = Gemstar 2x Custom 1
- 1110 = Custom 2
- 1111 = Active video (VDP off) (default)

A value of FFh in the line mode registers is required for any line to be sliced as part of the full field mode.

**3.21.74 Full Field Mode Register**

Address FCh  
 Default 7Fh

<b>7</b>	<b>6</b>	<b>5</b>	<b>4</b>	<b>3</b>	<b>2</b>	<b>1</b>	<b>0</b>
Full field mode							

This register programs the specific VBI standard for full field mode. It can be any VBI standard. Individual line settings take priority over the full field register. This allows each VBI line to be programmed independently but have the remaining lines in full field mode. The full field mode register has the same definitions as the line mode registers (default 7Fh).

## 4 Electrical Specifications

### 4.1 Absolute Maximum Ratings<sup>(1)</sup>

over operating free-air temperature range (unless otherwise noted)

Supply voltage range	IO_DVDD to DGND	–0.5 V to 4.5 V
	DVDD to DGND	–0.5 V to 2.3 V
	PLL_AVDD to PLL_AGND	–0.5 V to 2.3 V
	CH_AVDD to CH_AGND	–0.5 V to 2.3 V
Digital input voltage range, V <sub>I</sub> to DGND		–0.5 V to 4.5 V
Input voltage range, XTAL1 to PLL_GND		–0.5 V to 2.3 V
Analog input voltage range A <sub>I</sub> to CH_AGND		–0.2 V to 2.0 V
Digital output voltage range, V <sub>O</sub> to DGND		–0.5 V to 4.5 V
Operating free-air temperature, T <sub>A</sub>	Commercial	0°C to 70°C
	Industrial	–40°C to 85°C
Storage temperature range, T <sub>stg</sub>		–65°C to 150°C

(1) Stresses beyond those listed under absolute maximum ratings may cause permanent damage to the device. These are stress ratings only, and functional operation of the device at these or any other conditions beyond those indicated under recommended operating conditions is not recommended. Exposure to absolute-maximum-rated conditions for extended periods may affect device reliability.

### 4.2 Recommended Operating Conditions

		MIN	NOM	MAX	UNIT	
IO_DVDD	Digital I/O supply voltage	1.65	1.8 3.3	3.6	V	
DVDD	Digital supply voltage	1.65	1.8	1.95	V	
PLL_AVDD	Analog PLL supply voltage	1.65	1.8	1.95	V	
CH_AVDD	Analog core supply voltage	1.65	1.8	1.95	V	
V <sub>I(P-P)</sub>	Analog input voltage (ac-coupling necessary)	0		0.75	V	
V <sub>IH</sub>	Digital input voltage high <sup>(1)</sup>	0.7 IO_DVDD			V	
V <sub>IL</sub>	Digital input voltage low <sup>(1)</sup>			0.3 IO_DVDD	V	
V <sub>IH_XTAL</sub>	XTAL input voltage high <sup>(1)</sup>	0.7 PLL_AVDD			V	
V <sub>IL_XTAL</sub>	XTAL input voltage low <sup>(1)</sup>			0.3 PLL_AVDD	V	
I <sub>OH</sub>	High-level output current <sup>(1)</sup>			2	mA	
I <sub>OL</sub>	Low-level output current <sup>(1)</sup>			–2	mA	
I <sub>OH_SCLK</sub>	SCLK high-level output current <sup>(1)</sup>			4	mA	
I <sub>OL_SCLK</sub>	SCLK low-level output current <sup>(1)</sup>			–4	mA	
T <sub>A</sub>	Operating free-air temperature	Commercial		0	70	°C
		Industrial		–40	85	

(1) Specified by design

### 4.3 Reference Clock Specifications

		MIN	NOM	MAX	UNIT
f	Frequency		27		MHz
Δf	Frequency tolerance <sup>(1)</sup>	–50		+50	ppm

(1) Specified by design

#### 4.4 Electrical Characteristics

Typical supply voltages: DVDD = 1.8 V, PLL\_AVDD = 1.8 V, CH\_AVDD = 1.8 V, IO\_DVDD = 3.3 V,

For minimum/maximum values:  $T_A = 0^\circ\text{C}$  to  $70^\circ\text{C}$  for commercial or  $T_A = -40^\circ\text{C}$  to  $85^\circ\text{C}$  for industrial,

For typical values:  $T_A = 25^\circ\text{C}$  (unless otherwise noted)

#### 4.5 DC Electrical Characteristics

PARAMETER		TEST CONDITIONS <sup>(1)</sup>	MIN	TYP	MAX	UNIT
$I_{DD(IO\_D)}$	3.3-V I/O digital supply current	100% color bar input		6.9	7.9	mA
$I_{DD(D)}$	1.8-V digital supply current	100% color bar input		30	33.5	mA
$I_{DD(PLL\_A)}$	1.8-V analog PLL supply current	100% color bar input		5.7	7.9	mA
$I_{DD(CH\_A)}$	1.8-V analog core supply current	100% color bar input		27.9	39.2	mA
$P_{TOT}$	Total power dissipation, normal mode	100% color bar input		137	185	mW
$P_{DOWN}$	Total power dissipation, power-down mode <sup>(2)</sup>	100% color bar input			1	mW
$C_i$	Input capacitance <sup>(3)</sup>	By design		8		pF
$V_{OH}$	Output voltage high <sup>(3)</sup>	$I_{OH} = 2\text{ mA}$	0.8 IO_DVDD			V
$V_{OL}$	Output voltage low <sup>(3)</sup>	$I_{OL} = -2\text{ mA}$		0.22 IO_DVDD		V
$V_{OH\_SCLK}$	SCLK output voltage high <sup>(3)</sup>	$I_{OH} = 4\text{ mA}$	0.8 IO_DVDD			V
$V_{OL\_SCLK}$	SCLK output voltage low <sup>(3)</sup>	$I_{OL} = -4\text{ mA}$		0.22 IO_DVDD		V
$I_{IH}$	High-level input current <sup>(4)</sup>	$V_I = V_{IH}$			$\pm 20$	$\mu\text{A}$
$I_{IL}$	Low-level input current <sup>(4)</sup>	$V_I = V_{IL}$			$\pm 20$	$\mu\text{A}$

(1) Measured with 22- $\Omega$  series termination resistors and 10-pF load.

(2) Assured by device characterization

(3) Specified by design

(4) YOUT7 is a bidirectional terminal with an internal pulldown resistor. This terminal may sink more than the specified current when in RESET mode.

#### 4.6 Analog Electrical Characteristics

PARAMETER		TEST CONDITIONS	MIN	TYP	MAX	UNIT
$Z_i$	Input impedance, analog video inputs <sup>(1)</sup>			500		k $\Omega$
$C_i$	Input capacitance, analog video inputs <sup>(1)</sup>			10		pF
$V_{i(pp)}$	Input voltage range <sup>(2)</sup>	$C_{coupling} = 0.1\ \mu\text{F}$	0		0.75	V
$\Delta G$	Gain control maximum			12		dB
$\Delta G$	Gain control minimum			0		dB
DNL	Absolute differential nonlinearity	A/D only		0.5	1	LSB
INL	Absolute integral nonlinearity	A/D only		1	2.5	LSB
$F_r$	Frequency response	6 MHz, Specified by design		-0.9		dB
SNR	Signal-to-noise ratio	6 MHz, 1.0 $V_{P-P}$		50		dB
NS	Noise spectrum	50% flat field		50		dB
DP	Differential phase	Modulated ramp		0.5		$^\circ$
DG	Differential gain	Modulated ramp		1.5		%

(1) Specified by design

(2) The 0.75-V maximum applies to the sync-chrominance amplitude, not sync-white. The recommended termination resistors are 37.4  $\Omega$ , as seen in Section 6.



### 4.7 Clocks, Video Data, Sync Timing

PARAMETER	TEST CONDITIONS <sup>(1)</sup>	MIN	TYP	MAX	UNIT
Duty cycle, SCLK		47	50	53	%
t1	SCLK high time	≥90%	18.5		ns
t2	SCLK low time	≤10%	18.5		ns
t3	SCLK fall time	90% to 10%		5	ns
t4	SCLK rise time	10% to 90%		5	ns
t5	Propagation delay time	3		8	ns

(1) Measured with 22-Ω series termination resistors and 10-pF load.

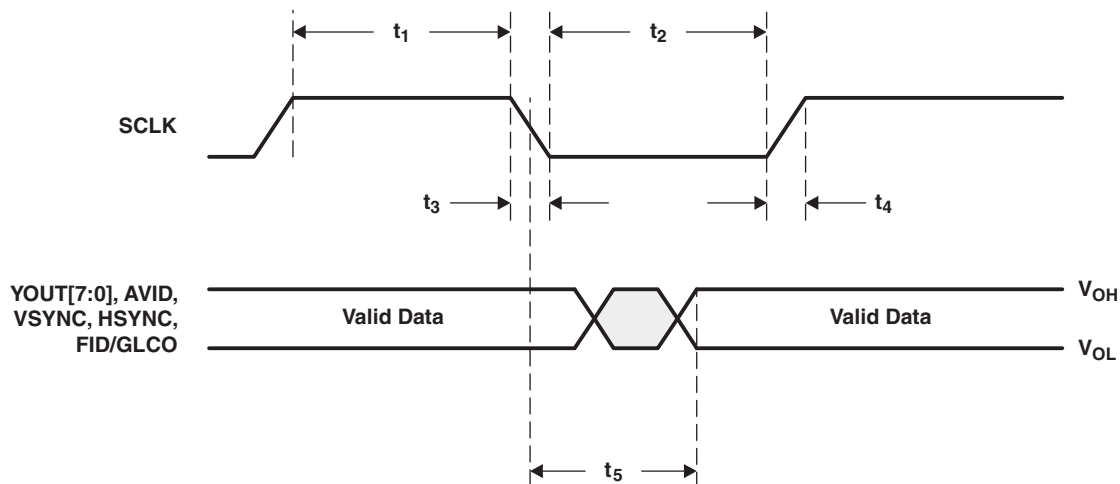

Figure 4-1. Clocks, Video Data, and Sync Timing

### 4.8 I<sup>2</sup>C Host Interface Timing<sup>(1)</sup>

NO.	PARAMETER	MIN	TYP	MAX	UNIT
t1	Bus free time between STOP and START	1.3			μs
t2	Data Hold time	0		0.9	μs
t3	Data Setup time	100			ns
t4	Setup time for a (repeated) START condition	0.6			μs
t5	Setup time for a STOP condition	0.6			ns
t6	Hold time (repeated) START condition	0.6			μs
t7	Rise time SDA and SCL signal			250	ns
t8	Fall time SDA and SCL signal			250	ns
C <sub>b</sub>	Capacitive load for each bus line			400	pF
f <sub>I2C</sub>	I <sup>2</sup> C clock frequency			400	kHz

(1) Specified by design

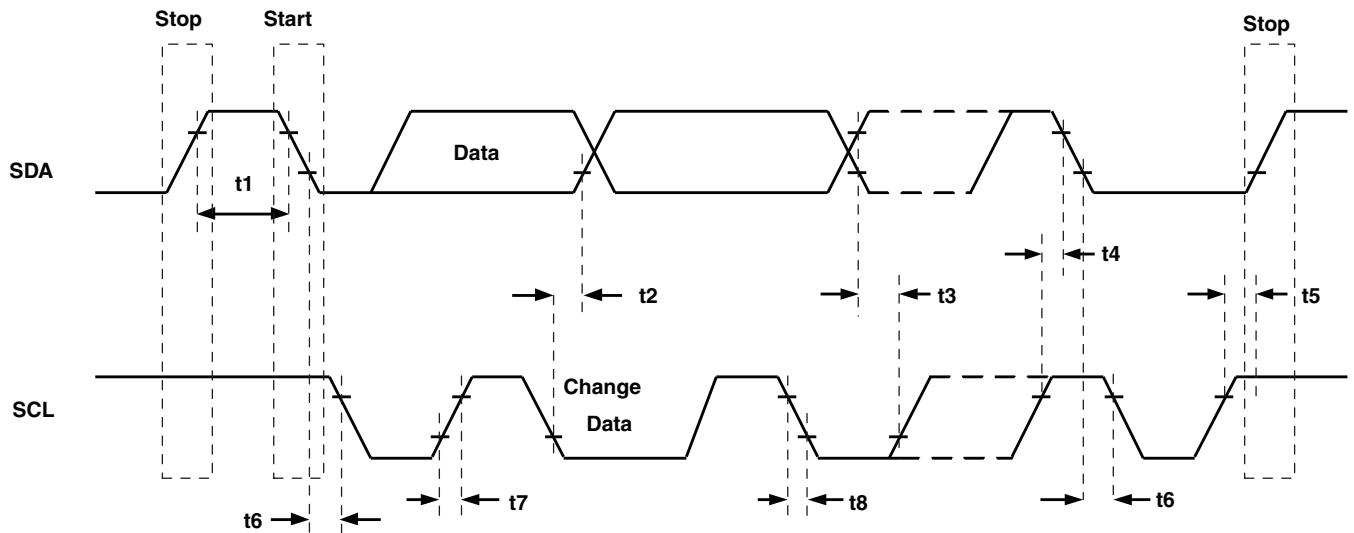

Figure 4-2. I<sup>2</sup>C Host Interface Timing

### 4.9 Thermal Specifications

PARAMETER	PACKAGE	BOARD	MIN	TYP	MAX	UNIT
θ <sub>JA</sub> Junction-to-ambient thermal resistance, still air	TQFP-32 (PBS)	JEDEC Low-K		125.3		°C/W
		JEDEC High-K		91.1		°C/W
θ <sub>JC</sub> Junction-to-case thermal resistance, still air	TQFP-32 (PBS)			39.3		°C/W
T <sub>J(MAX)</sub> Maximum junction temperature for reliable operation	TQFP-32 (PBS)				105	°C

## 5 Example Register Settings

The following example register settings are provided only as a reference. These settings, given the assumed input connector, video format, and output format, set up the TVP5151 decoder and provide video output. Example register settings for other features and the VBI data processor are not provided here.

### 5.1 Example 1

#### 5.1.1 Assumptions

Device: TVP5151

Input connector: Composite (AIP1A)

Video format: NTSC-M, PAL (B, G, H, I), or SECAM

---

#### NOTE

NTSC-4.43, PAL-N, and PAL-M are masked from the autoswitch process by default. See the autoswitch mask register at address 04h.

---

Output format: 8-bit ITU-R BT.656 with embedded syncs

#### 5.1.2 Recommended Settings

Recommended I<sup>2</sup>C writes: For this setup, only one write is required. All other registers are set up by default.

I<sup>2</sup>C register address 03h = Miscellaneous controls register address

I<sup>2</sup>C data 09h = Enables YCbCr output and the clock output

---

#### NOTE

HSYNC, VSYNC/PALI, AVID, and FID/GLCO are high impedance by default. See the miscellaneous control register at address 03h.

---

## 5.2 Example 2

### 5.2.1 Assumptions

Device: TVP5151

Input connector: S-video (AIP1A (luminance), AIP1B (chrominance))

Video Format: NTSC (M, 4.43), PAL (B, G, H, I, M, N, Nc) or SECAM (B, D, G, K1, L)

Output format: 8-bit 4:2:2 YCbCr with discrete sync outputs

### 5.2.2 Recommended Settings

Recommended I<sup>2</sup>C writes: This setup requires additional writes to output the discrete sync 4:2:2 data outputs, the HSYNC, and the VSYNC, and to autoswitch between all video formats mentioned above.

I<sup>2</sup>C register address 00h = Video input source selection #1 register

I<sup>2</sup>C data 01h = Selects the S-Video input, AIP1A (luminance), and AIP1B (chrominance)

I<sup>2</sup>C register address 03h = Miscellaneous controls register address

I<sup>2</sup>C data 0Dh = Enables the YCbCr output data, HSYNC, VSYNC/PALI, AVID, and FID/GLCO

I<sup>2</sup>C register address 04h = Autoswitch mask register

I<sup>2</sup>C data C0h = Unmask NTSC-4.43, PAL-N, and PAL-M from the autoswitch process

I<sup>2</sup>C register address 0Dh = Outputs and data rates select register

I<sup>2</sup>C data 40h = Enables 8-bit 4:2:2 YCbCr with discrete sync output

## 6 Application Information

### 6.1 Application Example

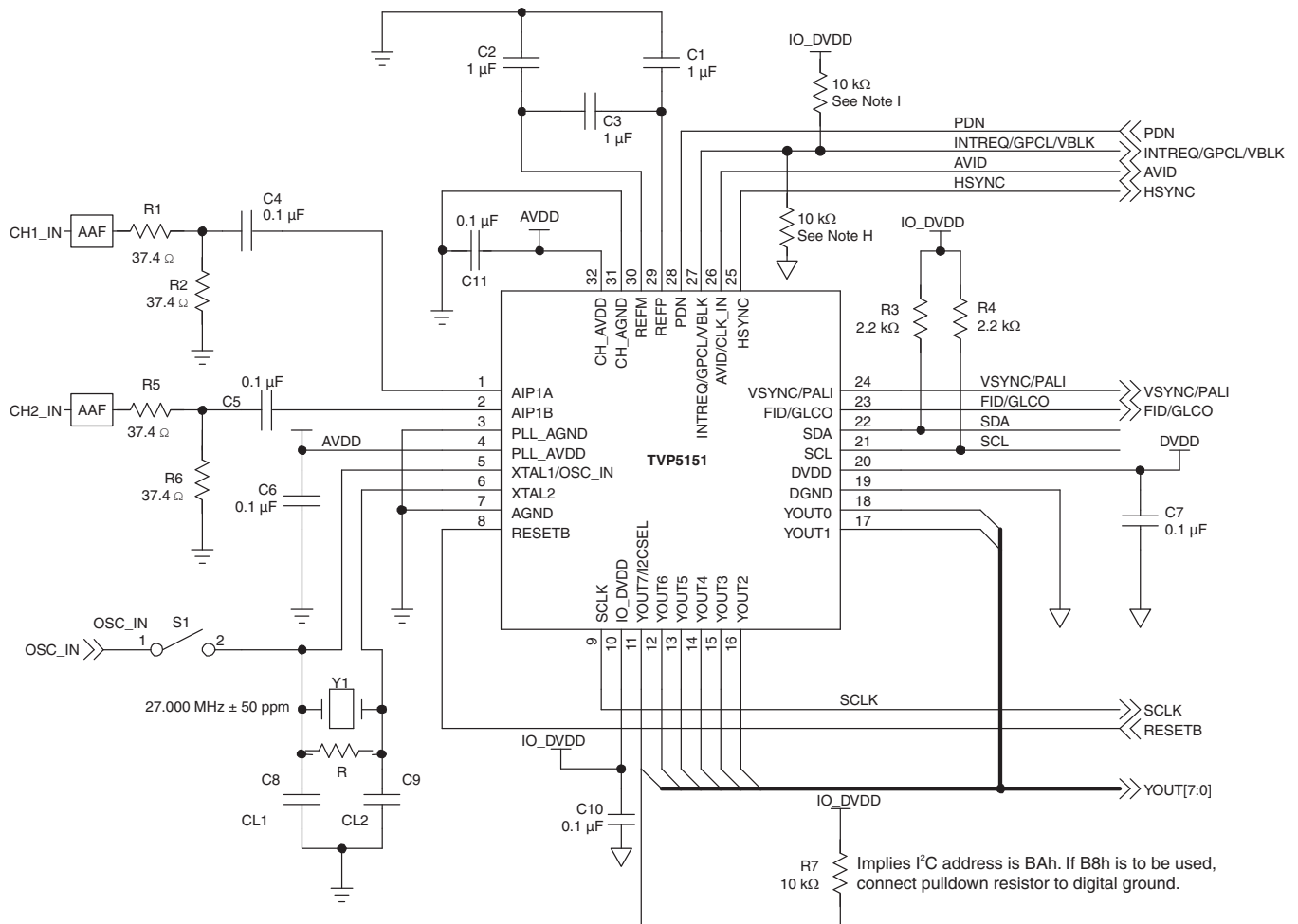

- A. The use of INTREQ/GPCL/VBLK, AVID, HSYNC, and VSYNC/PALI is optional.
- B. When OSC\_IN is connected through S1, remove the capacitors for the crystal.
- C. PDN needs to be high, if device has to be always operational.
- D. RESETB is operational only when PDN is high. This allows an active-low reset to the device.
- E. 100-kΩ resistor (R) in parallel with the crystal is recommended for most crystal types.
- F. Anti-aliasing filter (AAF) highly recommended for best video quality.
- G. System level ESD protection is not included in this application circuit, but it is highly recommended on the analog video inputs.
- H. An external 10-kΩ pulldown resistor is required when the INTREQ/GPCL/VBLK output (pin 27) is disabled (bit 5 of I<sup>2</sup>C register 03h is set to 0).
- I. An external 10-kΩ pullup resistor is required when the INTREQ/GPCL/VBLK output (pin 27) is enabled and configured as an active-low interrupt (bit 5 of I<sup>2</sup>C register 03h is set to 1, bit 1 of I<sup>2</sup>C register 0Fh is set to 0, and bit 0 of I<sup>2</sup>C register 1Eh is set to 0).

Figure 6-1. Application Example

## 7 Revision History

**Table 7-1. Revision History**

REVISION	COMMENTS
SLES241	Initial release
SLES241A	<p><a href="#">Section 1.4</a>, Related Products added</p> <p><a href="#">Section 1.5</a>, Trademarks modified</p> <p><a href="#">Section 3.16</a>, <a href="#">Figure 3-8</a> changed to depict various clocking options. Changed crystal parallel resistor recommendation.</p> <p><a href="#">Section 3.21.10</a>, Luminance Brightness description modified</p> <p><a href="#">Section 3.21.11</a>, Chrominance Saturation description modified</p> <p><a href="#">Section 3.21.50</a>, Status Register #3 description modified</p> <p><a href="#">Section 6.1</a>, Changed recommendation for resistor in parallel with the crystal</p> <p>Minor editorial changes throughout</p>
SLES241B	<p><a href="#">Section 3.3</a>, <a href="#">Figure 3-2</a>, Chroma trap filter characteristics for NTSC added.</p> <p><a href="#">Section 3.3</a>, <a href="#">Figure 3-3</a>, Chroma trap filter characteristics for PAL added.</p> <p><a href="#">Section 3.4</a>, <a href="#">Figure 3-4</a>, Color low-pass filter characteristics added.</p> <p><a href="#">Section 3.8</a>, <a href="#">Table 3-1</a>, Modified name for register 1100b.</p> <p><a href="#">Section 3.20</a>, <a href="#">Table 3-11</a>, Added I2C indirect registers at address 21h-24h.</p> <p><a href="#">Section 4.9</a>, Added Power Dissipation Ratings.</p>
SLES241C	<p>AEC-Q100 qualification added.</p> <p><a href="#">Section 3.13</a>, Updated description.</p> <p><a href="#">Section 3.21.29</a>, Added Indirect Register Data</p> <p><a href="#">Section 3.21.30</a>, Added Indirect Register Address</p> <p><a href="#">Section 3.21.31</a>, Added Indirect Register Read/Write Strobe</p> <p><a href="#">Section 3.21.38</a>, Added Patch Write Address</p> <p><a href="#">Section 3.21.39</a>, Added Patch Code Execute</p> <p><a href="#">Section 3.21.53</a>, Added Patch Read Address</p>
SLES241D	Removed AEC-Q100 qualification.
SLES241E	<p><a href="#">Table 2-1</a>, Modified description for terminal 27.</p> <p><a href="#">Table 3-11</a>, Modified registers 82h and 83h.</p> <p><a href="#">Section 3.21.4</a>, Modified description for bits 7:5 of I2C register 03h.</p> <p><a href="#">Section 3.21.15</a>, Removed support for 1x output clock frequency (bit 0 of register 0Fh).</p> <p><a href="#">Section 3.21.42</a>, Modified the register description for register 82h.</p> <p><a href="#">Section 3.21.43</a>, Modified the register description for register 83h.</p> <p><a href="#">Figure 6-1</a>, Added note concerning ESD protection. Added pulldown and pullup resistors to pin 27 output.</p>

**PACKAGING INFORMATION**

Orderable Device	Status (1)	Package Type	Package Drawing	Pins	Package Qty	Eco Plan (2)	Lead finish/ Ball material (6)	MSL Peak Temp (3)	Op Temp (°C)	Device Marking (4/5)	Samples
TVP5151IPBS	ACTIVE	TQFP	PBS	32	250	RoHS & Green	NIPDAU	Level-3-260C-168 HR	-40 to 85	5151I	<a href="#">Samples</a>
TVP5151IPBSR	ACTIVE	TQFP	PBS	32	1000	RoHS & Green	NIPDAU	Level-3-260C-168 HR	-40 to 85	5151I	<a href="#">Samples</a>
TVP5151PBS	ACTIVE	TQFP	PBS	32	250	RoHS & Green	NIPDAU	Level-3-260C-168 HR	0 to 70	5151	<a href="#">Samples</a>
TVP5151PBSR	ACTIVE	TQFP	PBS	32	1000	RoHS & Green	NIPDAU	Level-3-260C-168 HR	0 to 70	5151	<a href="#">Samples</a>

(1) The marketing status values are defined as follows:

**ACTIVE:** Product device recommended for new designs.

**LIFEBUY:** TI has announced that the device will be discontinued, and a lifetime-buy period is in effect.

**NRND:** Not recommended for new designs. Device is in production to support existing customers, but TI does not recommend using this part in a new design.

**PREVIEW:** Device has been announced but is not in production. Samples may or may not be available.

**OBSOLETE:** TI has discontinued the production of the device.

(2) **RoHS:** TI defines "RoHS" to mean semiconductor products that are compliant with the current EU RoHS requirements for all 10 RoHS substances, including the requirement that RoHS substance do not exceed 0.1% by weight in homogeneous materials. Where designed to be soldered at high temperatures, "RoHS" products are suitable for use in specified lead-free processes. TI may reference these types of products as "Pb-Free".

**RoHS Exempt:** TI defines "RoHS Exempt" to mean products that contain lead but are compliant with EU RoHS pursuant to a specific EU RoHS exemption.

**Green:** TI defines "Green" to mean the content of Chlorine (Cl) and Bromine (Br) based flame retardants meet JS709B low halogen requirements of <=1000ppm threshold. Antimony trioxide based flame retardants must also meet the <=1000ppm threshold requirement.

(3) **MSL, Peak Temp.** - The Moisture Sensitivity Level rating according to the JEDEC industry standard classifications, and peak solder temperature.

(4) There may be additional marking, which relates to the logo, the lot trace code information, or the environmental category on the device.

(5) Multiple Device Markings will be inside parentheses. Only one Device Marking contained in parentheses and separated by a "-" will appear on a device. If a line is indented then it is a continuation of the previous line and the two combined represent the entire Device Marking for that device.

(6) **Lead finish/Ball material** - Orderable Devices may have multiple material finish options. Finish options are separated by a vertical ruled line. Lead finish/Ball material values may wrap to two lines if the finish value exceeds the maximum column width.

**Important Information and Disclaimer:** The information provided on this page represents TI's knowledge and belief as of the date that it is provided. TI bases its knowledge and belief on information provided by third parties, and makes no representation or warranty as to the accuracy of such information. Efforts are underway to better integrate information from third parties. TI has taken and

continues to take reasonable steps to provide representative and accurate information but may not have conducted destructive testing or chemical analysis on incoming materials and chemicals. TI and TI suppliers consider certain information to be proprietary, and thus CAS numbers and other limited information may not be available for release.

In no event shall TI's liability arising out of such information exceed the total purchase price of the TI part(s) at issue in this document sold by TI to Customer on an annual basis.

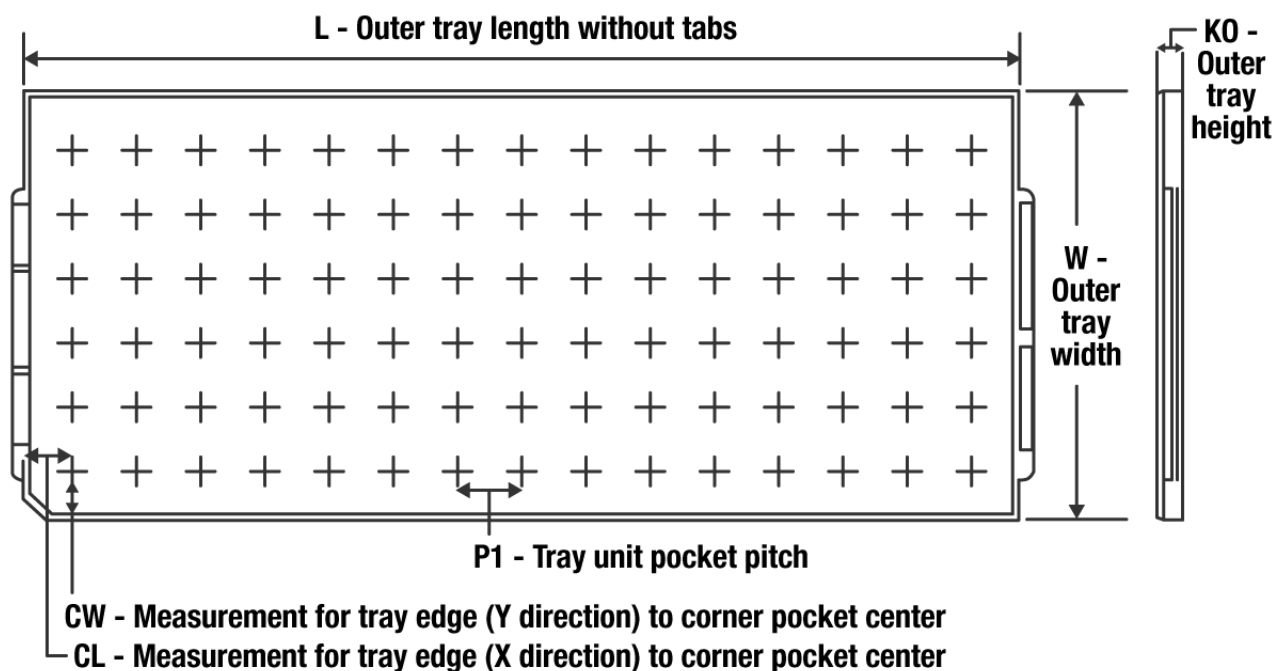

**TRAY**

Chamfer on Tray corner indicates Pin 1 orientation of packed units.

\*All dimensions are nominal

Device	Package Name	Package Type	Pins	SPQ	Unit array matrix	Max temperature (°C)	L (mm)	W (mm)	K0 (µm)	P1 (mm)	CL (mm)	CW (mm)
TVP5151PBS	PBS	TQFP	32	250	10 X 25	150	315	135.9	7620	12.2	11.1	11.25
TVP5151PBS	PBS	TQFP	32	250	10 X 25	150	315	135.9	7620	12.2	11.1	11.25

PBS (S-PQFP-G32)

PLASTIC QUAD FLATPACK

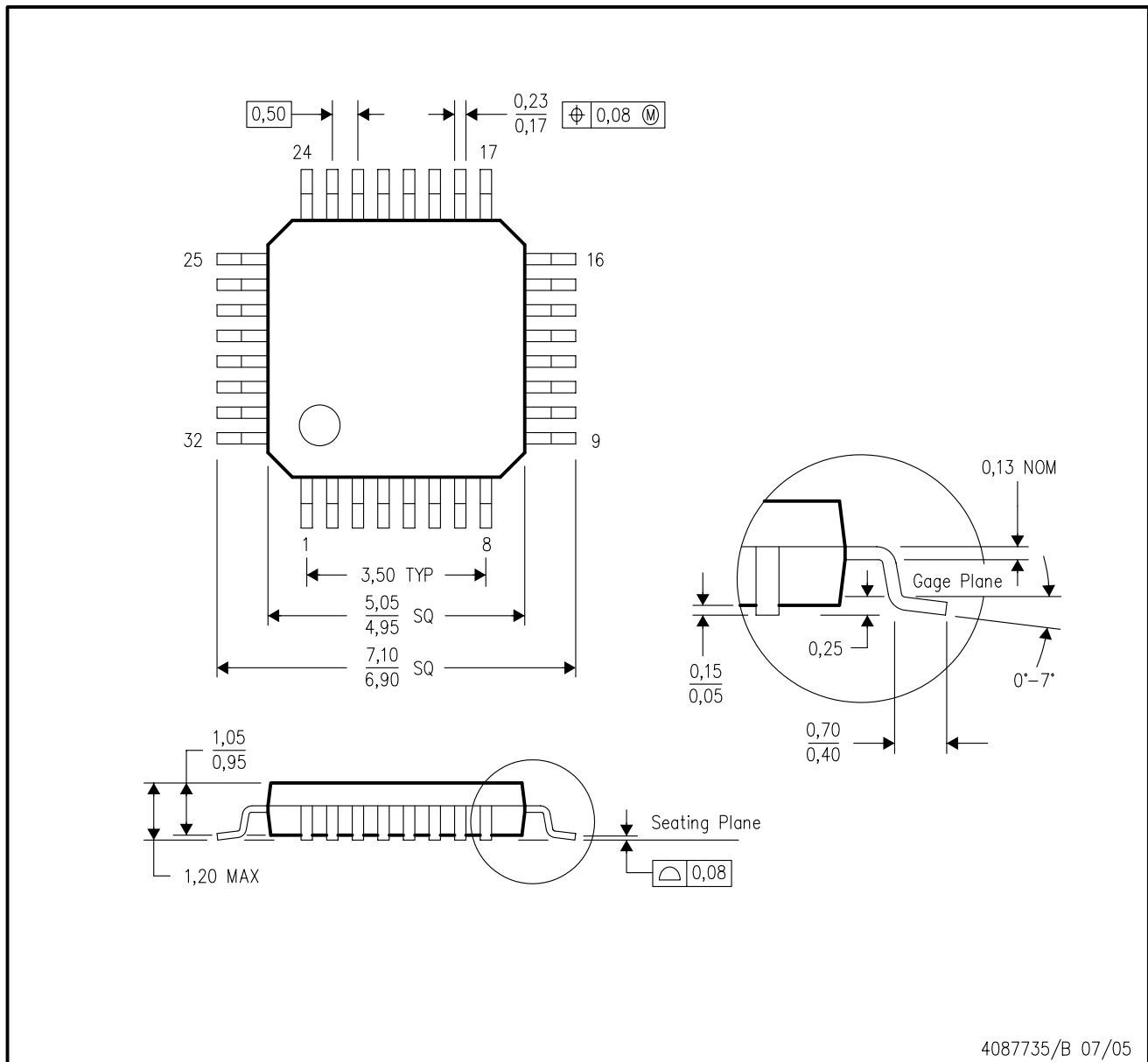

NOTES: A. All linear dimensions are in millimeters.  
 B. This drawing is subject to change without notice.

PBS (S-PQFP-G32)

PLASTIC QUAD FLATPACK

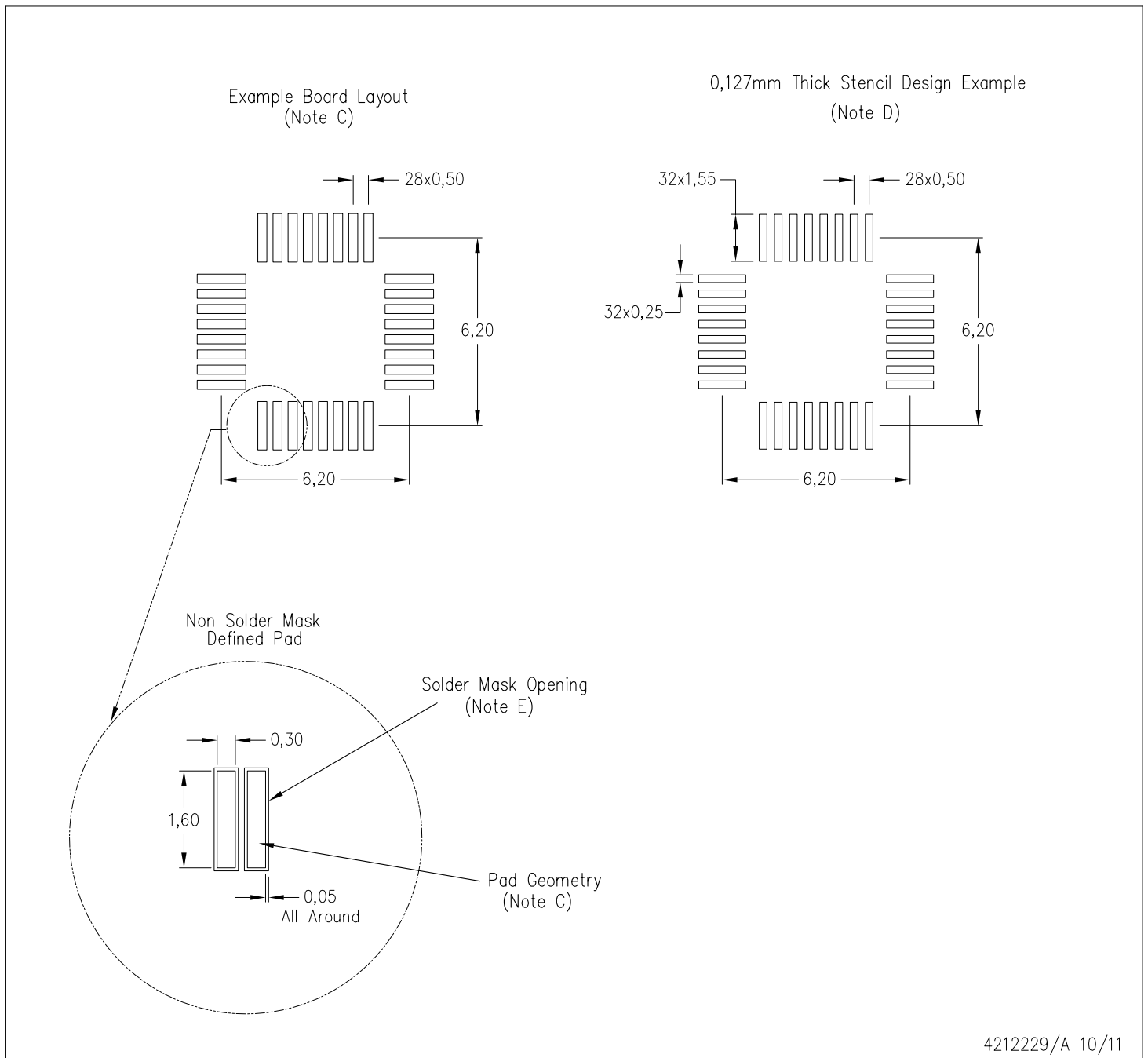

- NOTES:
- A. All linear dimensions are in millimeters.
  - B. This drawing is subject to change without notice.
  - C. Publication IPC-7351 is recommended for alternate designs.
  - D. Laser cutting apertures with trapezoidal walls and also rounding corners will offer better paste release. Customers should contact their board assembly site for stencil design recommendations. Refer to IPC 7525 for stencil design considerations.
  - E. Customers should contact their board fabrication site for recommended solder mask tolerances between and around signal pads.

## IMPORTANT NOTICE AND DISCLAIMER

TI PROVIDES TECHNICAL AND RELIABILITY DATA (INCLUDING DATA SHEETS), DESIGN RESOURCES (INCLUDING REFERENCE DESIGNS), APPLICATION OR OTHER DESIGN ADVICE, WEB TOOLS, SAFETY INFORMATION, AND OTHER RESOURCES "AS IS" AND WITH ALL FAULTS, AND DISCLAIMS ALL WARRANTIES, EXPRESS AND IMPLIED, INCLUDING WITHOUT LIMITATION ANY IMPLIED WARRANTIES OF MERCHANTABILITY, FITNESS FOR A PARTICULAR PURPOSE OR NON-INFRINGEMENT OF THIRD PARTY INTELLECTUAL PROPERTY RIGHTS.

These resources are intended for skilled developers designing with TI products. You are solely responsible for (1) selecting the appropriate TI products for your application, (2) designing, validating and testing your application, and (3) ensuring your application meets applicable standards, and any other safety, security, regulatory or other requirements.

These resources are subject to change without notice. TI grants you permission to use these resources only for development of an application that uses the TI products described in the resource. Other reproduction and display of these resources is prohibited. No license is granted to any other TI intellectual property right or to any third party intellectual property right. TI disclaims responsibility for, and you will fully indemnify TI and its representatives against, any claims, damages, costs, losses, and liabilities arising out of your use of these resources.

TI's products are provided subject to [TI's Terms of Sale](#) or other applicable terms available either on [ti.com](http://ti.com) or provided in conjunction with such TI products. TI's provision of these resources does not expand or otherwise alter TI's applicable warranties or warranty disclaimers for TI products.

TI objects to and rejects any additional or different terms you may have proposed.

Mailing Address: Texas Instruments, Post Office Box 655303, Dallas, Texas 75265  
Copyright © 2022, Texas Instruments Incorporated