

LTC3888

8-Phase, Dual-Output Synchronous Buck Converter with Power System Management

DESCRIPTION

Demonstration circuit 2652A-A is an 8-phase dual-output, high efficiency, high density, synchronous buck converter with 7V to 14V input range. Each output can supply up to 120A maximum load current with 1V output. The demo board showcases the [LTC®3888](#), which is a PMBus-compliant dual loop 8-phase step-down DC/DC controller with digital power system management. The LTC3888 is designed to work with DrMOS devices that provide an output current sense and temperature monitor. Please refer to LTC3888's data sheet for more detailed information.

DC2652A-A powers up to default settings and produces power based on configuration resistors (or with the setting in its non-volatile memory) without the need for any serial bus communication. This allows easy evaluation of

the DC/DC converter. To fully explore the extensive power system management features of the part, download the GUI software LTpowerPlay™ onto your PC and use ADI's I²C/SMBus/PMBus dongle DC1613A to connect to the board. LTpowerPlay allows the user to reconfigure the part on the fly and store the configuration in EEPROM, view telemetry of voltage, current, temperature and fault status.

GUI Download

The software can be downloaded from:

[here](#)

For more details and instructions of LTpowerPlay, please refer to LTpowerPlay Quick Start Procedure.

Design files for this circuit board are available.

All registered trademarks and trademarks are the property of their respective owners.

BOARD PHOTO

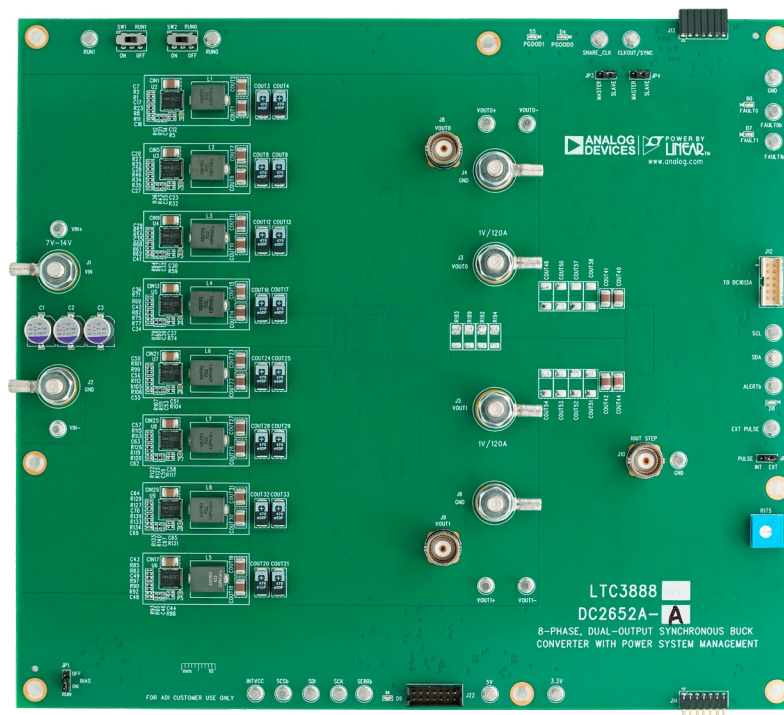

Figure 1. Dual-Output LTC3888/DC2652A-A Demo Circuit

DEMO MANUAL DC2652A-A

PERFORMANCE SUMMARY

Specifications are at $T_A = 25^\circ\text{C}$

PARAMETER	CONDITIONS	VALUE
Input Voltage Range		7V to 14V
Output Voltage, V_{OUT0}	$V_{IN} = 7$ to 14V, $I_{OUT0} = 0\text{A}$ to 120A	0.3 to 1.8V, Default: 1.0V
Maximum Output Current, I_{OUT0}	$V_{IN} = 7$ to 14V, $V_{OUT0} = 0.3\text{V}$ to 1.8V	120A
Output Voltage, V_{OUT1}	$V_{IN} = 7$ to 14V, $I_{OUT1} = 0\text{A}$ to 120A	0.3 to 1.8V, Default: 1.0V
Maximum Output Current, I_{OUT1}	$V_{IN} = 7$ to 14V, $V_{OUT1} = 0.3\text{V}$ to 1.8V	120A
Typical Efficiency of V_{OUT0}	$V_{IN} = 12\text{V}$, $V_{OUT0} = 1.0\text{V}$, $I_{OUT0} = 120\text{A}$	91.7%
Typical Efficiency of V_{OUT1}	$V_{IN} = 12\text{V}$, $V_{OUT1} = 1.0\text{V}$, $I_{OUT1} = 120\text{A}$	91.7%
Default Switching Frequency		500kHz

QUICK START PROCEDURE

DC2652A-A is easy to set up to evaluate the performance of LTC3888. Refer to Figure 2 for the proper measurement equipment setup and follow the procedure below.

1. With power off, connect the input power supply (7V-14V) to V_{IN} (J1) and GND (J2).
2. Connect the 1.0V output load (Initial load: no load) between V_{OUT0} (J3) and GND (J4).
3. Connect the 1.0V output load (Initial load: no load) between V_{OUT1} (J5) and GND (J6).
4. Connect the DMMs to the input and outputs. Set default jumper position:
 - JP1: ON
 - JP2: EXT
 - JP3: SLAVE
 - JP4: SLAVE
 - SW1: ON
 - SW2: ON
5. Turn on the input power supply and check for the proper output voltages. V_{OUT0} should be $1.0\text{V} \pm 0.5\%$ and V_{OUT1} should be $1.0\text{V} \pm 0.5\%$.
6. Once the proper output voltages are established, adjust the loads within the operating range and observe the output voltage regulation, ripple voltage and other parameters.
7. Connect the dongle and control the output voltages from the GUI. See LTpowerPlay Quick Start Procedure for details.

Note:

1. When measuring the efficiency, it is recommended to monitor the V_{IN} , V_{OUT0} and V_{OUT1} at the locations close to the power stage. Here are examples:
 - (1) Monitor V_{IN} across CIN9 and V_{OUT0} across C_{OUT11} for V_{OUT0} efficiency measurement
 - (2) Monitor V_{IN} across CIN29 and V_{OUT1} across C_{OUT31} for V_{OUT1} efficiency measurement
2. When measuring the output or input voltage ripple, do not use the long ground lead on the oscilloscope probe. Figure 3 for the proper scope probe technique. Short, stiff leads need to be soldered to the (+) and (-) terminals of an output capacitor. The probe's ground ring needs to touch the (-) lead and the probe tip needs to touch the (+) lead.
3. When doing the load transient test, it is recommended to use a function generator to generate a pulse (~3% duty cycle with 10Hz~100Hz frequency). Then applying this pulse to the EXT PULSE (E9) and GND (E10) turrets, the dynamic load circuit will work well to achieve desired load transient test by adjusting the amplitude, rising edge and falling edge of the pulse. Here are examples:
 - (1) Set the amplitude of the pulse to 3.4V for a 0A to 30A load transient test with $10\text{m}\Omega$ I_{OUT} sensing resistor
 - (2) Set the amplitude of the pulse to 3.6V for a 0A to 40A load transient test with $10\text{m}\Omega$ I_{OUT} sensing resistor

QUICK START PROCEDURE

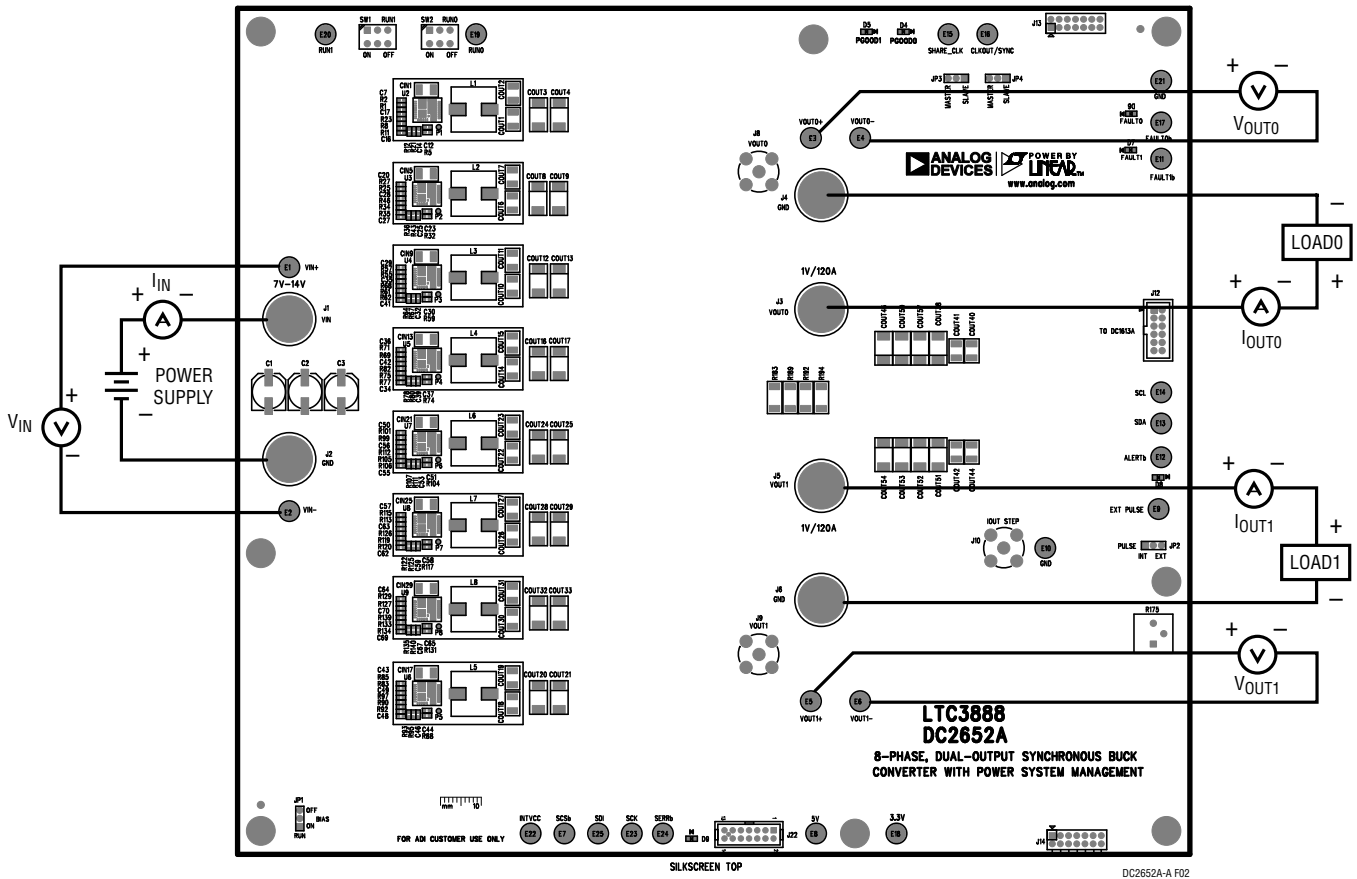

Figure 2. Proper Measurement Equipment Setup

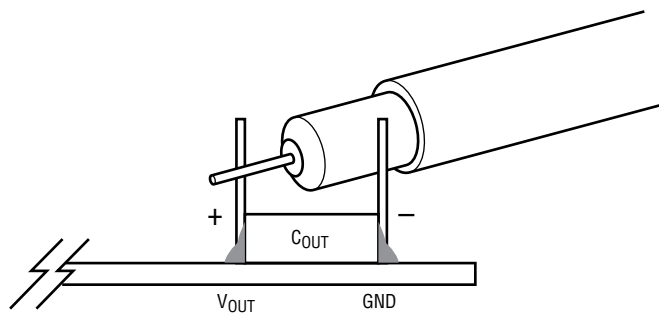

Figure 3. Measuring Output Voltage Ripple

DEMO MANUAL DC2652A-A

QUICK START PROCEDURE

Connecting a PC to DC2652A-A

You can use a PC to reconfigure the power management features of LTC3888 such as: nominal V_{OUT} , margin set

points, OV/UV limits, temperature fault limits, sequencing parameters, the fault log, fault responses, GPIOs and other functionalities. The DC1613A dongle may be plugged when V_{IN} is present.

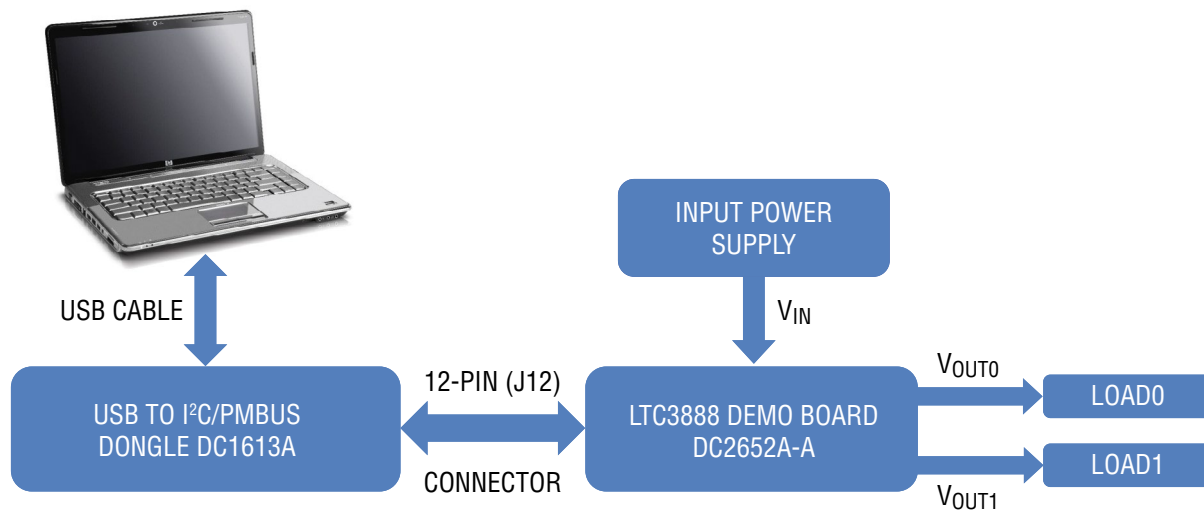

Figure 4. Demo Setup with PC

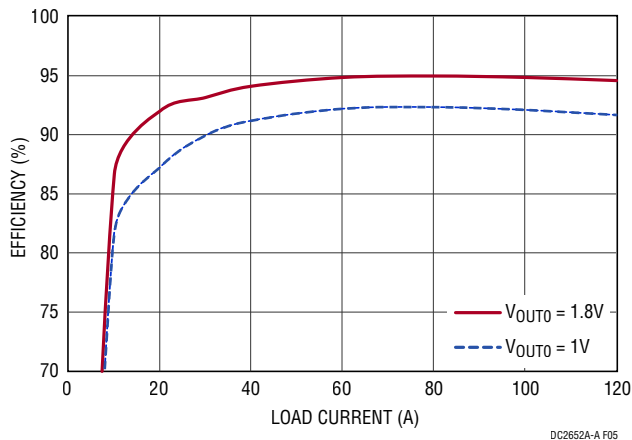

Figure 5. Efficiency vs. Load Current on V_{OUT0}

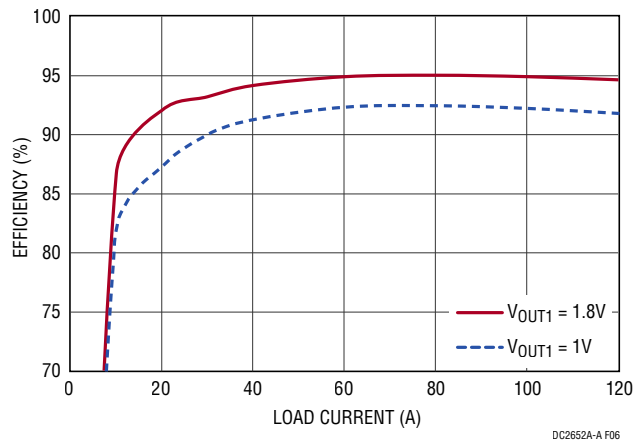

Figure 6. Efficiency vs. Load Current on V_{OUT1}

QUICK START PROCEDURE

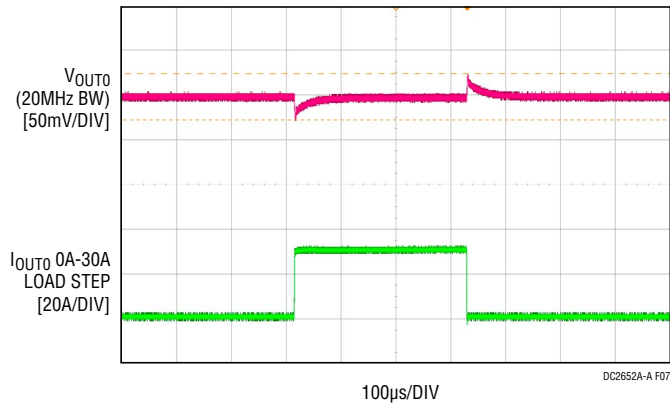

Figure 7. V_{OUT0} Load Transient Response at V_{IN} = 12V, V_{OUT0} = 1.0V

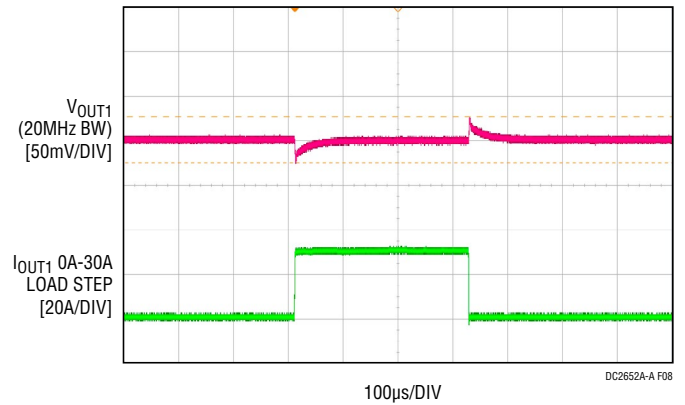

Figure 8. V_{OUT1} Load Transient Response at V_{IN} = 12V, V_{OUT1} = 1.0V

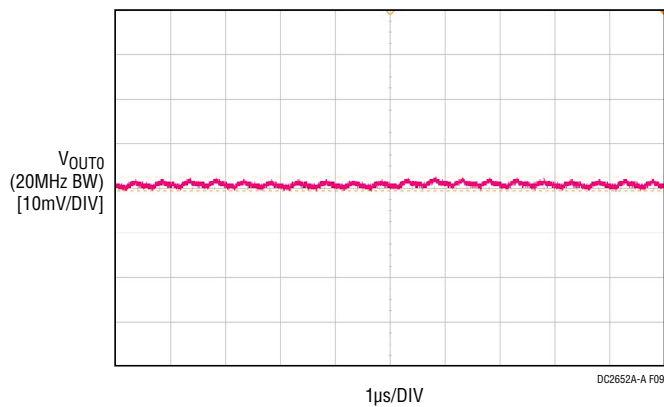

Figure 9. V_{OUT0} Voltage Ripple at V_{IN} = 12V, V_{OUT0} = 1.0V, I_{OUT0} = 120A

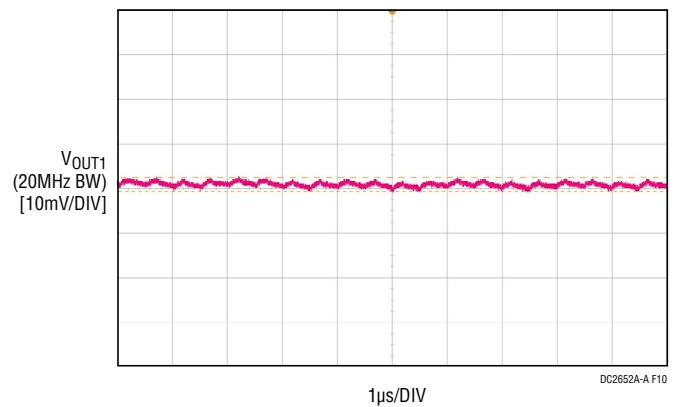

Figure 10. V_{OUT1} Voltage Ripple at V_{IN} = 12V, V_{OUT1} = 1.0V, I_{OUT1} = 120A

QUICK START PROCEDURE

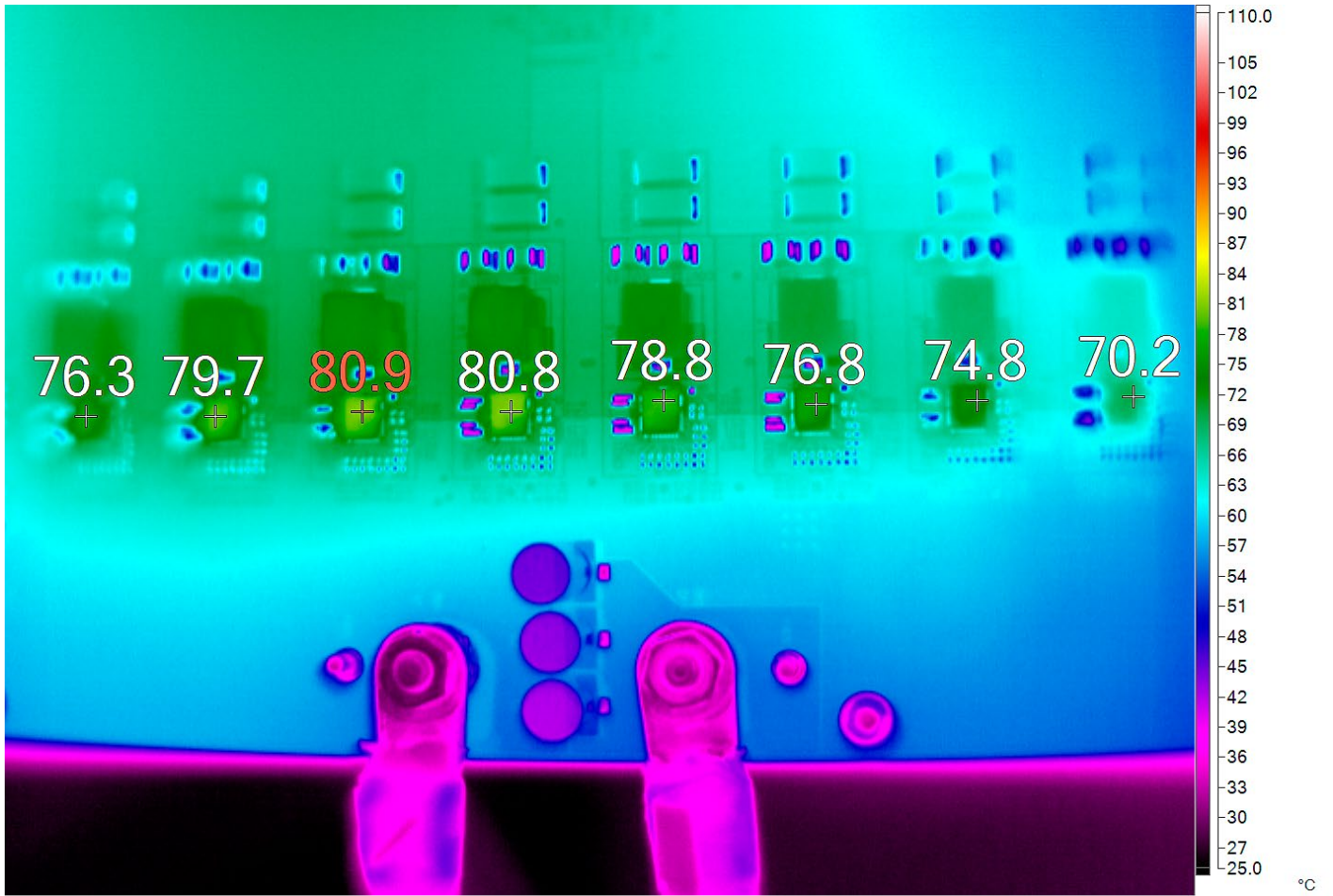

Figure 11. Thermal at $V_{IN} = 12V$, $V_{OUT0} = 1.0V$, $I_{OUT0} = 120A$, $V_{OUT1} = 1.0V$, $I_{OUT1} = 120A$, $T_A = 23^\circ C$, No Airflow

LTPOWERPLAY SOFTWARE GUI

LTpowerPlay is a powerful Windows based development environment that supports Analog Devices power system management ICs and μ Modules, including LTM4675, LTM4676, LTM4677, LTM4678, LTM4680, LTM4700, LTC3880, LTC3882, LTC3883, LTC3884 and LTC3888. The software supports a variety of different tasks. You can use LTpowerPlay to evaluate Analog Devices ICs by connecting to a demo board system. LTpowerPlay can also be used in an offline mode (with no hardware present) in order to build a multichip configuration file that can be saved and reloaded at a later time. LTpowerPlay provides unprecedented diagnostic and debug features. It becomes a valuable diagnostic tool during board bring-up to program or tweak the power management scheme in a system, or to diagnose power issues when bringing

up rails. LTpowerPlay utilizes the DC1613A USB-to-I²C/SMBus/PMBus controller to communicate with one of many potential targets, including LTM4675, LTM4676, LTM4677, LTM4678, LTM4680, LTM4700, LTC3880, LTC3882, LTC3883, LTC3884 and LTC3888's demo system, or a customer board. The software also provides an automatic update feature to keep the software current with the latest set of device drivers and documentation. The LTpowerPlay software can be downloaded from:

[here](#)

To access technical support documents for ADI's Digital Power System Management Products, visit the LTpowerPlay Help menu.

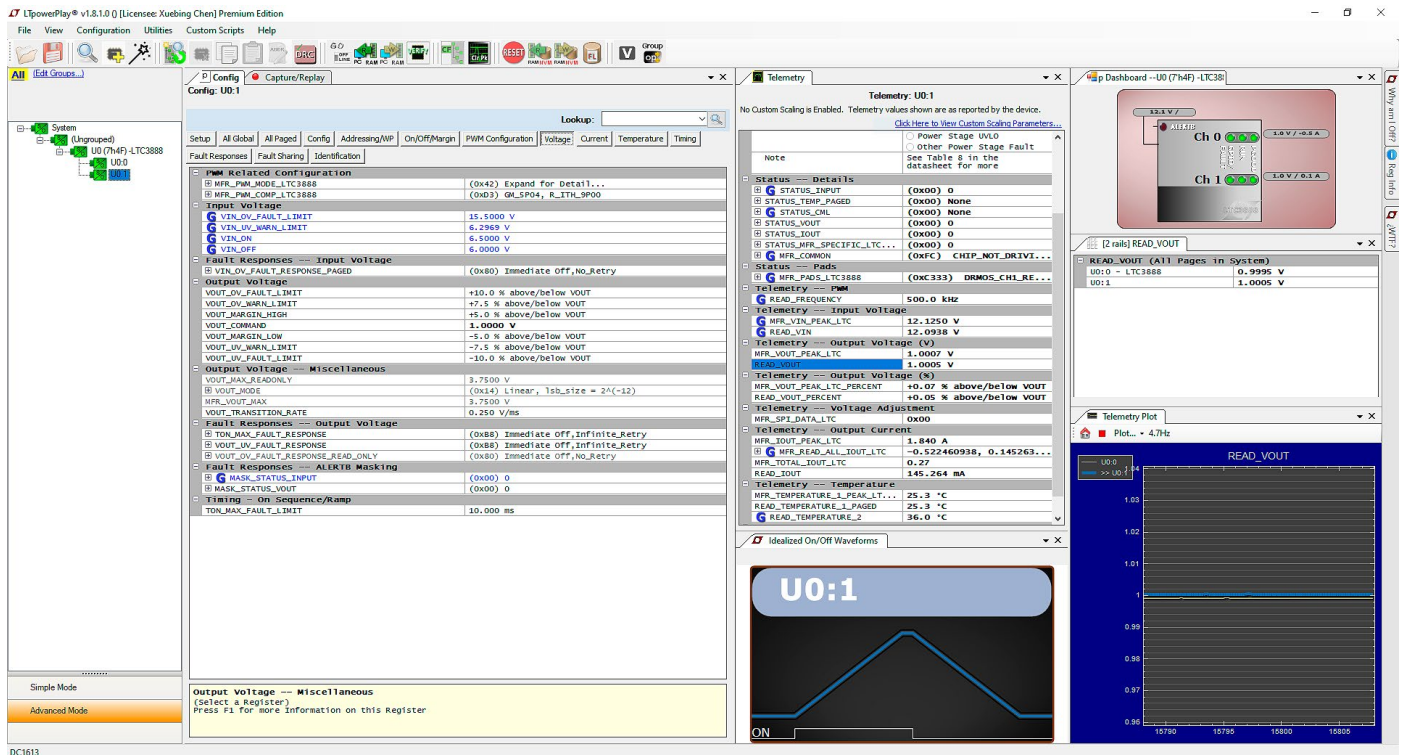

Figure 12. LTpowerPlay Main Interface

DEMO MANUAL DC2652A-A

LTPOWERPLAY QUICK START PROCEDURE

The following procedure describes how to use LTpowerPlay to monitor and change the settings of LTC3888.

1 Download and install the LTpowerPlay GUI:

[here](#)

2. Launch the LTpowerPlay GUI.

a. The GUI should automatically identify the DC2652A-A. The system tree on the left hand side should look like this:

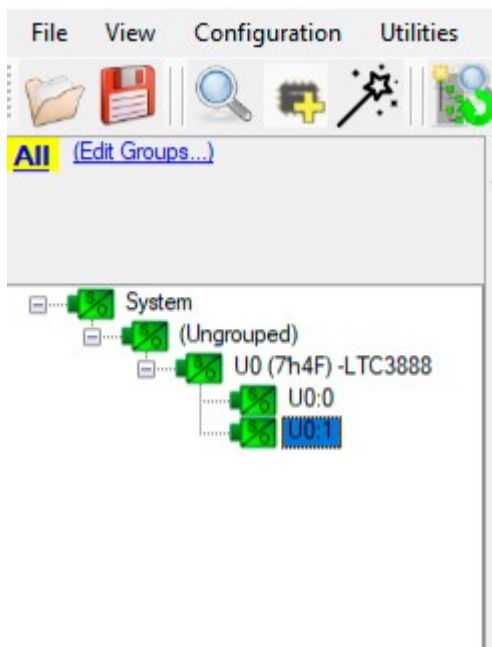

b. A green message box shows for a few seconds in the lower left-hand corner, confirming that LTC3888 is communicating:

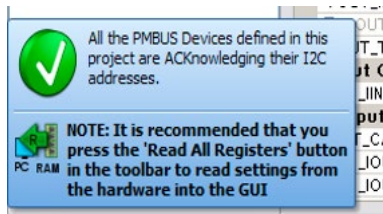

c. In the Toolbar, click the “R” (RAM to PC) icon to read the RAM from the LTC3888. This reads the configuration from the RAM of LTC3888 and loads it into the GUI.



d. If you want to change the output voltage to a different value, like 1.8V. In the Config tab, type in 1.8 in the VOUT_COMMAND box, like this:

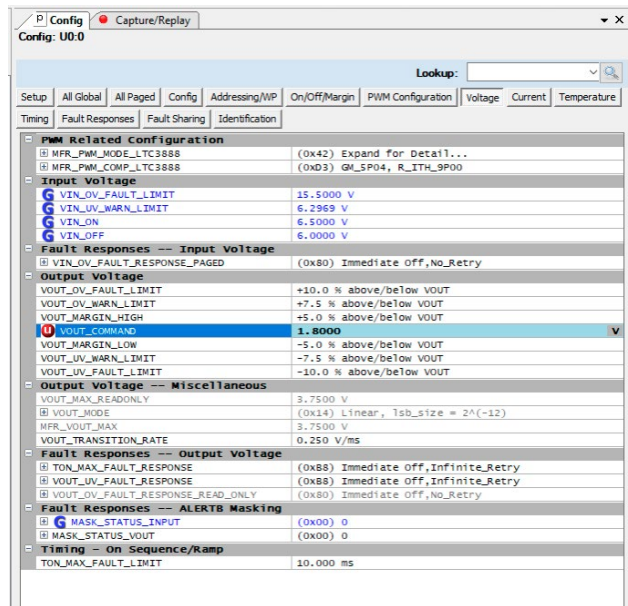

Then, click the “W” (PC to RAM) icon to write these register values to the LTC3888. After finishing this step, you will see the output voltage will change to 1.8V.



If the write is successful, you will see the following message:



e. You can save the changes into the NVM. In the toolbar, click “RAM to NVM” button, as following



f. Save the demo board configuration to a (*.proj) file. Click the Save icon and save the file. Name it whatever you want.

PARTS LIST

ITEM	QTY	REFERENCE	PART DESCRIPTION	MANUFACTURER/PART NUMBER
Required Circuit Components				
1	6	C1, C2, C3, C4, C5, C6	CAP., 270µF, ALUM, 16V, 20%, SMD 8 × 11.9mm, E12	PANASONIC/16SVPC270M
2	18	COUT1, COUT2, COUT6, COUT7, COUT10, COUT11, COUT14, COUT15, COUT18, COUT19, COUT22, COUT23, COUT26, COUT27, COUT30, COUT31, COUT64, COUT65	CAP., 100µF, X5R, 6.3V, 20%, 1210	AVX/12106D107MAT2A
3	32	CIN1, CIN2, CIN3, CIN4, CIN5, CIN6, CIN7, CIN8, CIN9, CIN10, CIN11, CIN12, CIN13, CIN14, CIN15, CIN16, CIN17, CIN18, CIN19, CIN20, CIN21, CIN22, CIN23, CIN24, CIN25, CIN26, CIN27, CIN28, CIN29, CIN30, CIN31, CIN32	CAP., 22µF, X7R, 25V, 10%, 1210	AVX/12103C226KAT2A
4	16	COUT3, COUT4, COUT8, COUT9, COUT12, COUT13, COUT16, COUT17, COUT20, COUT21, COUT24, COUT25, COUT28, COUT29, COUT32, COUT33	CAP., 470µF, TANT, POSCAP, 2.5V, 20%, 7343, TPF Series	PANASONIC/ETPF470M5H
5	16	C7, C16, C20, C27, C29, C34, C36, C41, C43, C48, C50, C55, C57, C62, C64, C69	CAP., 0.47µF, X5R, 10V, 10%, 0402	AVX/0402ZD474KAT2A
6	1	C8	CAP., 4.7µF, X5R, 16V, 20%, 0603	MURATA/GRM188R61C475MAAJD
7	1	C9	CAP., 1µF, X7R, 16V, 20%, 0603	AVX/0603YC105MAT2A
8	1	C10	CAP., 2.2µF, X5R, 16V, 10%, 0603	KEMET/C0603C225K4PAC7867
9	2	C11, C108	CAP., 2.2µF, X5R, 16V, 10%, 0805	AVX/0805YD225KAT2A
10	16	C12, C14, C23, C25, C30, C32, C37, C39, C44, C46, C51, C53, C58, C59, C65, C67	CAP., 4.7µF, JB, 10V, 20%, 0402	TDK/C1005JB1A475M050BC
11	8	C17, C28, C35, C42, C49, C56, C63, C70	CAP., 330pF, X7R, 50V, 10%, 0402	AVX/04025C331KAT2A
12	2	C18, C19	CAP., 3300pF, X7R, 50V, 10%, 0603	AVX/06035C332KAT2A
13	2	C21, C22	CAP., 330pF, X7R, 50V, 10%, 0603	KEMET/C0603S331K5RAC7867
14	3	CIN33, CIN34, COUT67	CAP., 10µF, X7R, 16V, 10%, 1210	AVX/1210YC106KAT2A
15	1	COUT66	CAP., 4.7µF, X5R, 16V, 20%, 1210	AVX/1210YD475MAT2A
16	2	C110, C113	CAP., 1µF, X7R, 50V, 10%, 0805	MURATA/GRM21BR71H105KA12L
17	1	C111	CAP., 4.7µF, X5R, 16V, 10%, 0603	AVX/0603YD475KAT2A
18	1	C112	CAP., 0.1µF, X7R, 16V, 10%, 0603	AVX/0603YC104KAT2A
19	1	C114	CAP., 5.6pF, COG/NPO, 50V, ±0.25pF, 0603	AVX/06035A5R6CAT2
20	1	C116	CAP., 100pF, COG/NPO, 25V, 5%, 0603	AVX/06033A101JAT2
21	1	D1	DIODE, SCHOTTKY, 200V, 1A, PowerDI-123, AEC-Q101	DIODES INC./DFLS1200-7
22	8	L1, L2, L3, L4, L5, L6, L7, L8	IND., 215nH, PWR, FERRITE, 10%, 61A, 0.29mΩ, 10.4 × 8.0mm SMD	EATON/FP1007R3-R22-R
23	1	L9	IND., 4.7µH, PWR, 20%, 5.9A, 40mΩ, 5.48 × 5.28mm SMD, XAL5030, AEC-Q200	COILCRAFT/XAL5030-472ME

DEMO MANUAL DC2652A-A

PARTS LIST

ITEM	QTY	REFERENCE	PART DESCRIPTION	MANUFACTURER/PART NUMBER
24	1	R3	RES., 1 Ω , 5%, 1/10W, 0603, AEC-Q200	VISHAY/CRCW06031R00JNEA
25	3	R9, R10, R18	RES., 1k Ω , 1%, 1/10W, 0603, AEC-Q200	NIC/NRC06F1001TRF
26	7	R15, R17, R48, R49, R51, R54, R244	RES., 10k Ω , 1%, 1/10W, 0603, AEC-Q200	KOA SPEER/RK73H1JTTD1002F
27	1	R16	RES., 4.99k Ω , 1%, 1/10W, 0603, AEC-Q200	NIC/NRC06F4991TRF
28	8	R23, R46, R68, R82, R97, R112, R126, R139	RES., 10k Ω , 1%, 1/16W, 0402, AEC-Q200	NIC/NRC04F1002TRF
29	1	R41	RES., 18.7k Ω , 1%, 1/10W, 0603, AEC-Q200	NIC/NRC06F1872TRF
30	1	R53	RES., 2k Ω , 1%, 1/10W, 0603, AEC-Q200	KOA SPEER/RK73H1JTTD2001F
31	4	R89, R98, R234, R235	RES., 10 Ω , 1%, 1/10W, 0603	NIC/NRC06F10R0TRF
32	1	R250	RES., 2 Ω , 1%, 1/10W, 0603, AEC-Q200	VISHAY/CRCW06032R00FKEA
33	1	R251	RES., 100k Ω , 1%, 1/10W, 0603, AEC-Q200	PANASONIC/ERJ3EKF1003V
34	1	R252	RES., 60.4k Ω , 1%, 1/10W, 0603, AEC-Q200	PANASONIC/ERJ3EKF6042V
35	1	R253	RES., 619k Ω , 1%, 1/10W, 0603, AEC-Q200	NIC/NRC06F6193TRF
36	1	R255	RES., 200k Ω , 1%, 1/10W, 0603	NIC/NRC06F2003TRF
37	1	R256	RES., 84.5k Ω , 1%, 1/10W, 0603, AEC-Q200	NIC/NRC06F8452TRF
38	1	U1	IC, 8-Phase, Dual Output Synch. Buck Cvrtr, QFN-52 (UHG)	LINEAR TECH/LTC3888IUHG#PBF
39	8	U2, U3, U4, U5, U6, U7, U8, U9	IC, Powerstage Gate Driver, DrMOS, PQFN 5mm x 6mm, 70A	INFINEON/TDA21470AUMA1
40	1	U22	IC, 1A SYNC. STEP-DOWN CONVERTER, DFN-14	LINEAR TECH/LTC3646EDE-1#PBF

Additional Demo Board Circuit Components

1	0	C13, C24, C31, C38, C45, C52, C60, C66	CAP., OPTION, 0402	
2	0	C15, C26, C33, C40, C47, C54, C61, C68, C115, C119, C121, C122	CAP., OPTION, 0603	
3	0	COUT38, COUT45, COUT46, COUT50, COUT51, COUT52, COUT53, COUT54, COUT57, COUT58, COUT59, COUT62	CAP., OPTION, 7343	
4	4	COUT39, COUT60, COUT61, COUT63	CAP., 470 μ F, TANT, POSCAP, 2.5V, 20%, 7343, TPF Series	PANASONIC/ETPF470M5H
5	10	COUT40, COUT41, COUT42, COUT44, COUT47, COUT48, COUT55, COUT56, C84, C85	CAP., 100 μ F, X5R, 6.3V, 20%, 1210	AVX/12106D107MAT2A
6	2	COUT43, COUT49	CAP., 1 μ F, X7R, 16V, 20%, 0603	AVX/0603YC105MAT2A
7	4	C102, C103, C105, C106	CAP., 10 μ F, X5R, 10V, 10%, 0603	AVX/0603ZD106KAT2A
8	2	C104, C107	CAP., 0.01 μ F, C0G, 25V, 5%, 0603	AVX/06033A103JAT2
9	1	C86	CAP., 0.1 μ F, X7R, 50V, 10%, 0603	AVX/06035C104KAT2A
10	2	C87, C89	CAP., 1 μ F, X7R, 16V, 20%, 0603	AVX/0603YC105MAT2
11	1	C88	CAP., 150pF, C0G, 25V, 10%, 0603	AVX/06033A151KAT2
12	1	C90	CAP., 0.1 μ F, X7R, 50V, 10%, 0603	AVX/06035C104KAT2A
13	2	C91, C92	CAP., 0.01 μ F, C0G, 25V, 5%, 0603	AVX/06033A103JAT2A
14	6	C99, C100, C101, C117, C118, C120	CAP., 0.1 μ F, X7R, 50V, 10%, 0603	AVX/06035C104KAT2A
15	0	D2, D3	DIODE, OPTION, SOD-323	

PARTS LIST

ITEM	QTY	REFERENCE	PART DESCRIPTION	MANUFACTURER/PART NUMBER
16	2	D4, D5	LED, GREEN, WATER CLEAR, 0603	Würth/150060GS75000
17	3	D6, D7, D8	LED, SUPER RED, WATERCLEAR, 0603	Würth/150060SS75000
18	1	D9	LED, SUPER RED, WATERCLEAR, 0603	Würth/150060SS75000
19	6	D10, D11, D12, D13, D14, D15	DIODE, SCHOTTKY, 20V, 0.5A, SOD-882, LEADLESS	NEXPERIA/PMEG2005AEL,315
20	2	Q1, Q2	XSTR., MOSFET, N-CH, 40V, 14A, DPAK (TO-252)	VISHAY/SUD50N04-8M8P-4GE3
21	4	Q3, Q4, Q5, Q6	XSTR., MOSFET, P-CH, 30V, 3.5A, SOT23-3, AEC-Q101	DIODES INC./DMP3130L-7
22	2	Q7, Q8	XSTR., MOSFET, N-CH, 60V, 210mA, SOT-23	DIODES INC./2N7002-13-F
23	1	Q9	XSTR., MOSFET, P-CH, 30V, 3.5A, SOT23-3, AEC-Q101	DIODES INC./DMP3130L-7
24	64	R1, R2, R5, R6, R8, R12, R21, R22, R25, R27, R29, R32, R34, R36, R43, R50, R55, R57, R58, R59, R61, R64, R66, R67, R69, R71, R72, R74, R75, R78, R80, R81, R83, R85, R86, R88, R90, R93, R95, R96, R99, R101, R102, R104, R105, R107, R110, R111, R113, R115, R116, R117, R119, R122, R124, R125, R127, R129, R130, R131, R133, R135, R138, R140	RES., 0 Ω , 1/16W, 0402	NIC/NRC04ZOTRF
25	0	R4, R7, R11, R26, R33, R35, R56, R60, R62, R70, R73, R77, R84, R87, R92, R100, R103, R106, R114, R118, R120, R128, R132, R134	RES., OPTION, 0402	
26	14	R28, R30, R166, R198, R200, R202, R203, R257, R276, R279, R281, R283, R286, R288	RES., 0 Ω , 1/10W, 0603, AEC-Q200	NIC/NRC06ZOTRF
27	0	R37, R38, R39, R40, R42, R44, R47, R52, R179, R180, R181, R182, R187, R188, R191, R196, R197, R199, R201, R204, R210, R211, R212, R213, R268, R269, R274, R275, R277, R278, R280, R282, R284, R285, R287, R289, R290, R291, R292	RES., OPTION, 0603	
28	0	R162, R163, R183, R184, R189, R190, R192, R193, R194, R195	RES., OPTION, 2010	
29	1	R164	RES., 2 Ω , 1%, 1/10W, 0603, AEC-Q200	VISHAY/CRCW06032R00FKEA
30	1	R165	RES., 3.3 Ω , 1%, 1/10W, 0603, AEC-Q200	VISHAY/CRCW06033R30FKEA
31	1	R167	RES., 154k Ω , 1%, 1/10W, 0603, AEC-Q200	NIC/NRC06F1543TR
32	1	R168	RES., 1M Ω , 1%, 1/10W, 0603, AEC-Q200	NIC/NRC06F1004TRF
33	2	R169, R170	RES., 20k Ω , 1%, 1/10W, 0603	NIC/NRC06F2002TRF
34	1	R171	RES., 681k Ω , 1%, 1/10W, 0603, AEC-Q200	NIC/NRC06F6813TRF
35	2	R172, R218	RES., 10k Ω , 1%, 1/10W, 0603, AEC-Q200	KOA SPEER/RK73H1JTTD1002F
36	1	R173	RES., 301 Ω , 1%, 1/10W, 0603, AEC-Q200	NIC/NRC06F3010TRF

DEMO MANUAL DC2652A-A

PARTS LIST

ITEM	QTY	REFERENCE	PART DESCRIPTION	MANUFACTURER/PART NUMBER
37	1	R174	RES., 82.5Ω, 1%, 1/10W, 0603, AEC-Q200	NIC/NRC06F82R5TRF
38	1	R175	RES., 5kΩ, 10%, 1/2W, THT 3/8" SQ, 1-TURN, TOP ADJ., TRIMPOT	BOURNS/3386P-1-502LF
39	0	R176	RES., OPTION, 2512	
40	1	R177	RES., 0.01Ω, 1%, 1W, 2512, PWR, METAL, SENSE, AEC-Q200	VISHAY/WSL2512R0100FEA
41	1	R178	RES., 1.21kΩ, 1%, 1/10W, 0603	PANASONIC/ERJ3EKF1211V
42	2	R185, R186	RES., 27.4Ω, 1%, 1W, 2512, AEC-Q200	PANASONIC/ERJ1TNF27R4U
43	2	R205, R206	RES., 10Ω, 1%, 1/10W, 0603	NIC/NRC06F10R0TRF
44	2	R207, R208	RES., 4.99kΩ, 1%, 1/10W, 0603, AEC-Q200	NIC/NRC06F4991TRF
45	0	R209	RES., OPTION, 1206	
46	5	R214, R215, R216, R217, R219	RES., 2kΩ, 1%, 1/10W, 0603, AEC-Q200	KOA SPEER/RK73H1JTDD2001F
47	1	R220	RES., 15.8kΩ, 1%, 1/10W, 0603, AEC-Q200	NIC/NRC06F1582TRF
48	1	R233	RES., 2kΩ, 1%, 1/10W, 0603, AEC-Q200	KOA SPEER/RK73H1JTDD2001F
49	1	R258	RES., 0Ω, 1/8W, 0805	VISHAY/CRCW08050000Z0EA
50	2	R242, R246	RES., 332kΩ, 1%, 1/10W, 0603, AEC-Q200	NIC/NRC06F3323TRF
51	2	R243, R245	RES., 3.32kΩ, 1%, 1/10W, 0603, AEC-Q200	PANASONIC/ERJ3EKF3321V
52	2	R262, R263	RES., 1Ω, 1%, 1/8W, 0805, AEC-Q200	VISHAY/CRCW08051R00FKEA
53	7	R259, R260, R261, R264, R267, R272, R273	RES., 1Ω, 5%, 1/10W, 0603, AEC-Q200	VISHAY/CRCW06031R00JNEA
54	3	R265, R266, R270	RES., 10kΩ, 1%, 1/10W, 0603, AEC-Q200	KOA SPEER/RK73H1JTDD1002F
55	1	U13	OSC., 3.81Hz to 1MHz, 5pF, 90ppm, TSOT23-6	ANALOG DEVICES/LTC6992IS6-1#PBF
56	1	U14	IC, Single R to R In/Out Op Amp, TSOT23-5, 100V/μs, 85MHz	ANALOG DEVICES/LT1803IS5#PBF
57	1	U15	IC,EEPROM, I ² C, TSSOP-8, 2Kb (256 × 8), 400kHz	MICROCHIP/24LC024-I/ST
58	1	U18	IC, TRANSLATING TRANSCEIVER, XQFN-12	NXP/NTB0104GU12,115
59	1	U19	IC, SWITCH QUAD SPST, TSSOP-16	ANALOG DEVICES/ADG711BRUZ
60	2	U20, U21	IC, 1.1A ADJ. SINGLE RESISTOR LDO, MSOP-8	LINEAR TECH/LT3080EMS8E-1#PBF
61	1	U23	IC, 4-BIT DUAL-SUPPLY BUS XCVR, TSSOP-16	TEXAS INSTRUMENTS/SN74AVC4T774PW
62	1	U24	IC, DUAL BUFFER GATE, SOT23-6	TEXAS INSTRUMENTS/SN74LVC2G34DBV
63	1	U25	IC, I ² C BUS TO SPI BRIDGE, TSSOP-16	NXP/SC18IS602BIPW, 112

PARTS LIST

ITEM	QTY	REFERENCE	PART DESCRIPTION	MANUFACTURER/PART NUMBER
Hardware: For Demo Board Only				
1	4	XJP1, XJP2, XJP3, XJP4	CONN., SHUNT, FEMALE, 2 POS, 2mm	Würth/60800213421
2	8	MP1, MP2, MP3, MP4, MP5, MP6, MP7, MP8	STANDOFF, NYLON, SNAP-ON, 0.50"	Würth/702935000
3	25	E1, E2, E3, E4, E5, E6, E7, E8, E9, E10, E11, E12, E13, E14, E15, E16, E17, E18, E19, E20, E21, E22, E23, E24, E25	TEST POINT, TURRET, 0.094" MTG. HOLE, PCB 0.062" THK	MILL-MAX/2501-2-00-80-00-00-07-0
4	6	J1, J2, J3, J4, J5, J6	STUD, FASTENER, #10-32	PennEngineering/KFH-032-10ET
5	12	J1, J2, J3, J4, J5, J6	NUT, HEX, #10-32, STEEL, ZINC PLATE	KEYSTONE/4705
6	6	J1, J2, J3, J4, J5, J6	RING, LUG, #10, CRIMP, 16/14 AWG, NON-INSULATED, SOLDERLESS TERMINALS	KEYSTONE/8205
7	6	J1, J2, J3, J4, J5, J6	WASHER, FLAT, STEEL, ZINC PLATE, OD: 0.436 [11.1]	KEYSTONE/4703
8	4	JP1, JP2, JP3, JP4	CONN., HDR, MALE, 1 × 3, 2mm, VERT, ST, THT	Würth/62000311121
9	3	J8, J9, J10	CONN., RF, BNC, RCPT, JACK, 5-PIN, ST, THT, 50Ω	AMPHENOL RF/112404
10	1	J12	CONN., HDR, SHROUDED, MALE, 2 × 6, 2mm, VERT, ST, THT	AMPHENOL/98414-G06-12ULF
11	1	J13	CONN., HDR, FEMALE, 2 × 7, 2mm, R/A THT	SOLUTIONS/NPPN072FJFN-RC
12	1	J14	CONN., HDR, MALE, 2 × 7, 2mm, R/A THT	MOLEX/0877601416
13	1	J22	CONN., HDR, SHROUDED, MALE, 2 × 7, 2mm, VERT, ST, THT	MOLEX/87831-1420
14	2	SW1, SW2	SWITCH, SLIDE, DPDT, 0.3A, 6VDC, PTH	C&K/JS202011CQN

DEMO MANUAL DC2652A-A

SCHEMATIC DIAGRAM

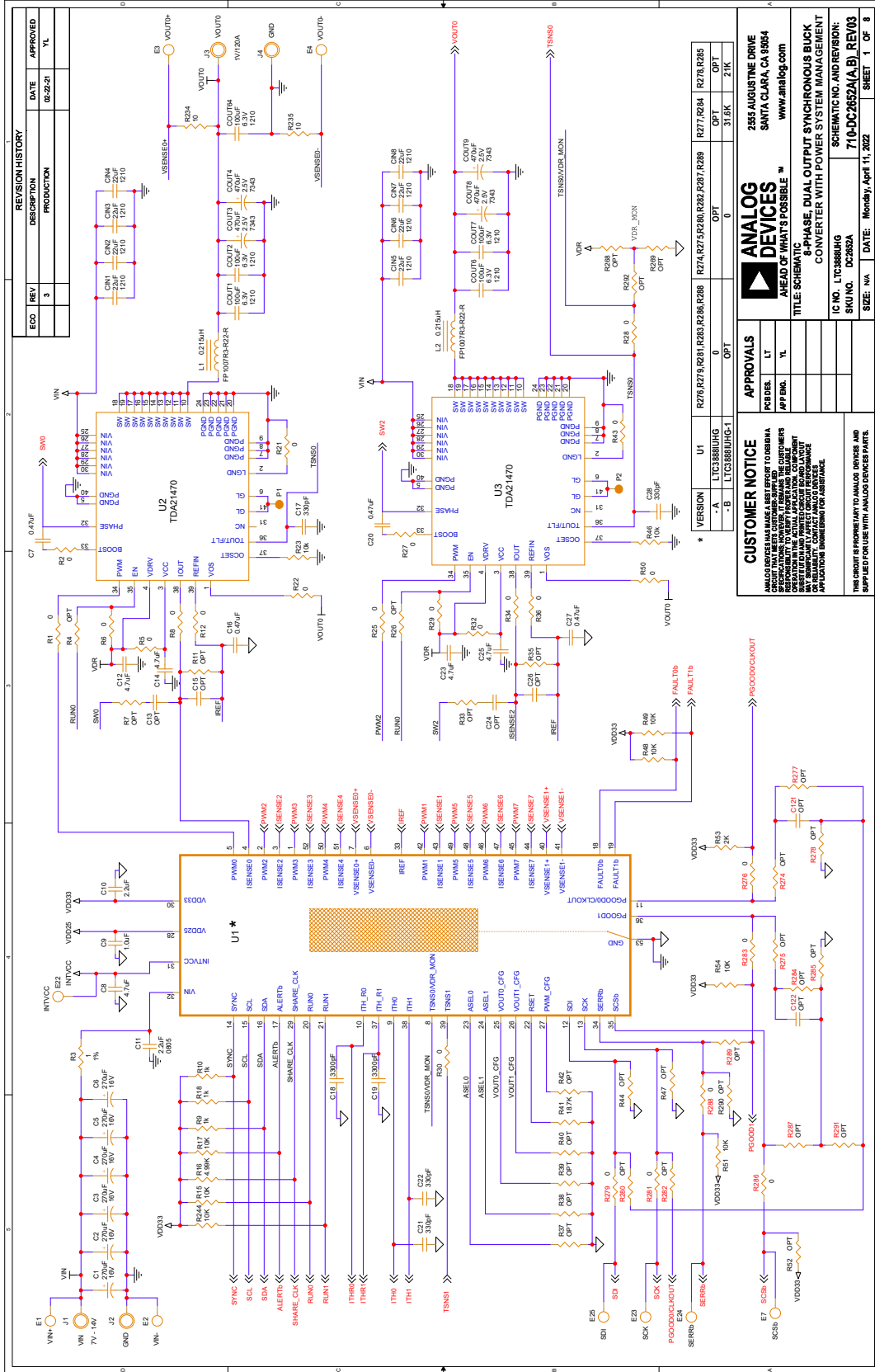

SCHEMATIC DIAGRAM

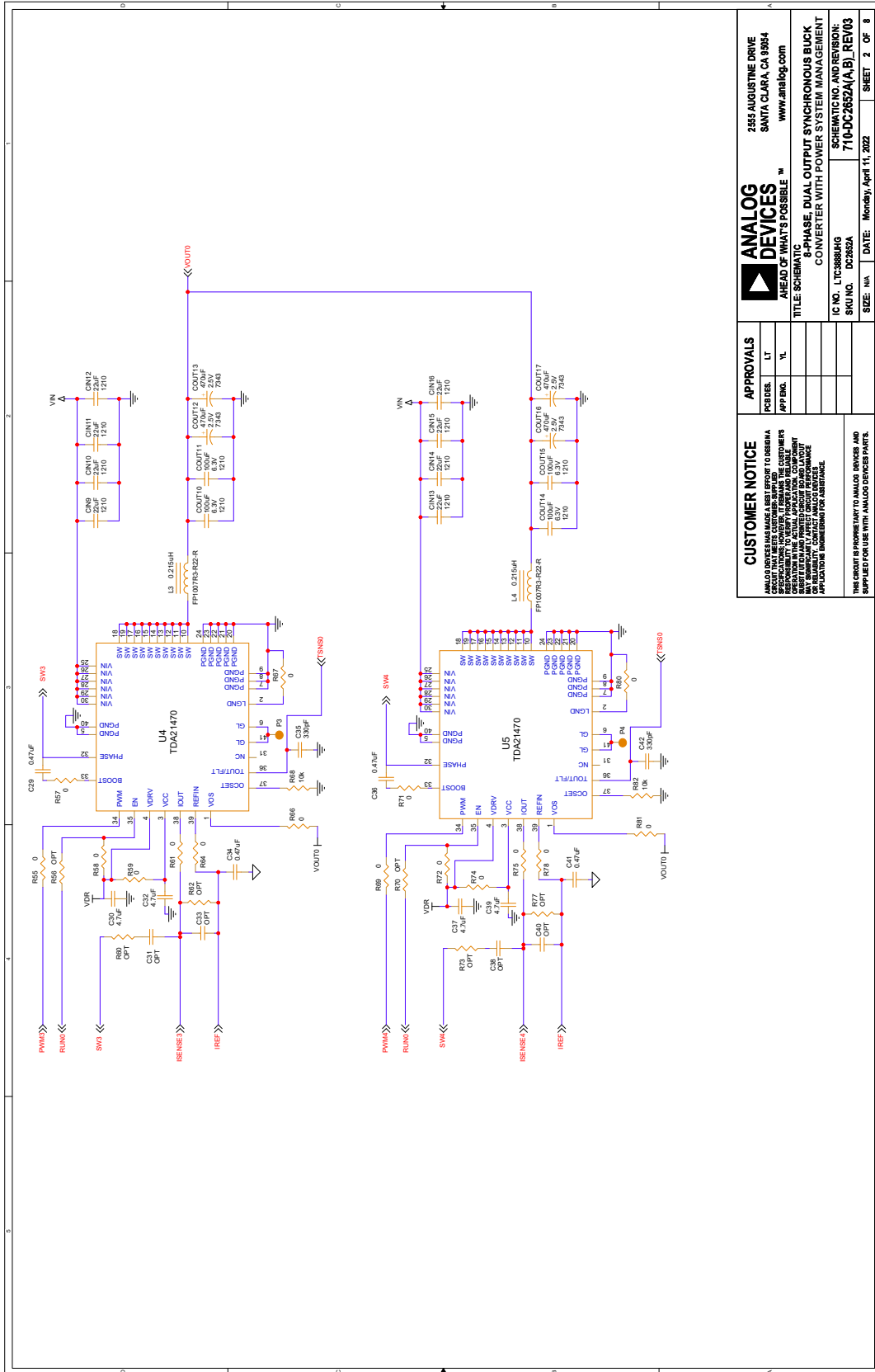

ANALOG DEVICES 255 AUGUSTINE DRIVE SANTA CLARA, CA 95054 www.analog.com	
TITLE SCHEMATIC 8-PHASE, DUAL OUTPUT SYNCHRONOUS BUCK CONVERTER WITH POWER SYSTEM MANAGEMENT	
IC NO. LTC3888BG	SCHEMATIC NO. AND REVISION: 710-DC2652A(A,B)_REV03
SKU NO. DC2652A	DATE: Monday, April 11, 2022
SIZE: 1/4x	SHEET 2 OF 8

CUSTOMER NOTICE
ANALOG DEVICES MAKES A BEST EFFORT TO DESIGN A SCHEMATIC AND BOARD LAYOUT THAT WILL OPERATE AS SPECIFIED. HOWEVER, IT REMAINS THE CUSTOMER'S RESPONSIBILITY TO VERIFY THE SCHEMATIC AND BOARD LAYOUT IN THE ACTUAL APPLICATION. COMPONENT VALUES, BOARD LAYOUT, AND MANUFACTURING VARIATIONS MAY SIGNIFICANTLY AFFECT CIRCUIT PERFORMANCE. APPLICATION ENGINEERING FOR ASSISTANCE.

APPROVALS

DESIGNER	LT
APP ENG	YL

DESIGNER'S COMMENTS: NO ANALOG DEVICES AND REVISIONS
APPLICABLE TO THIS BOARD LAYOUT.

DEMO MANUAL DC2652A-A

SCHEMATIC DIAGRAM

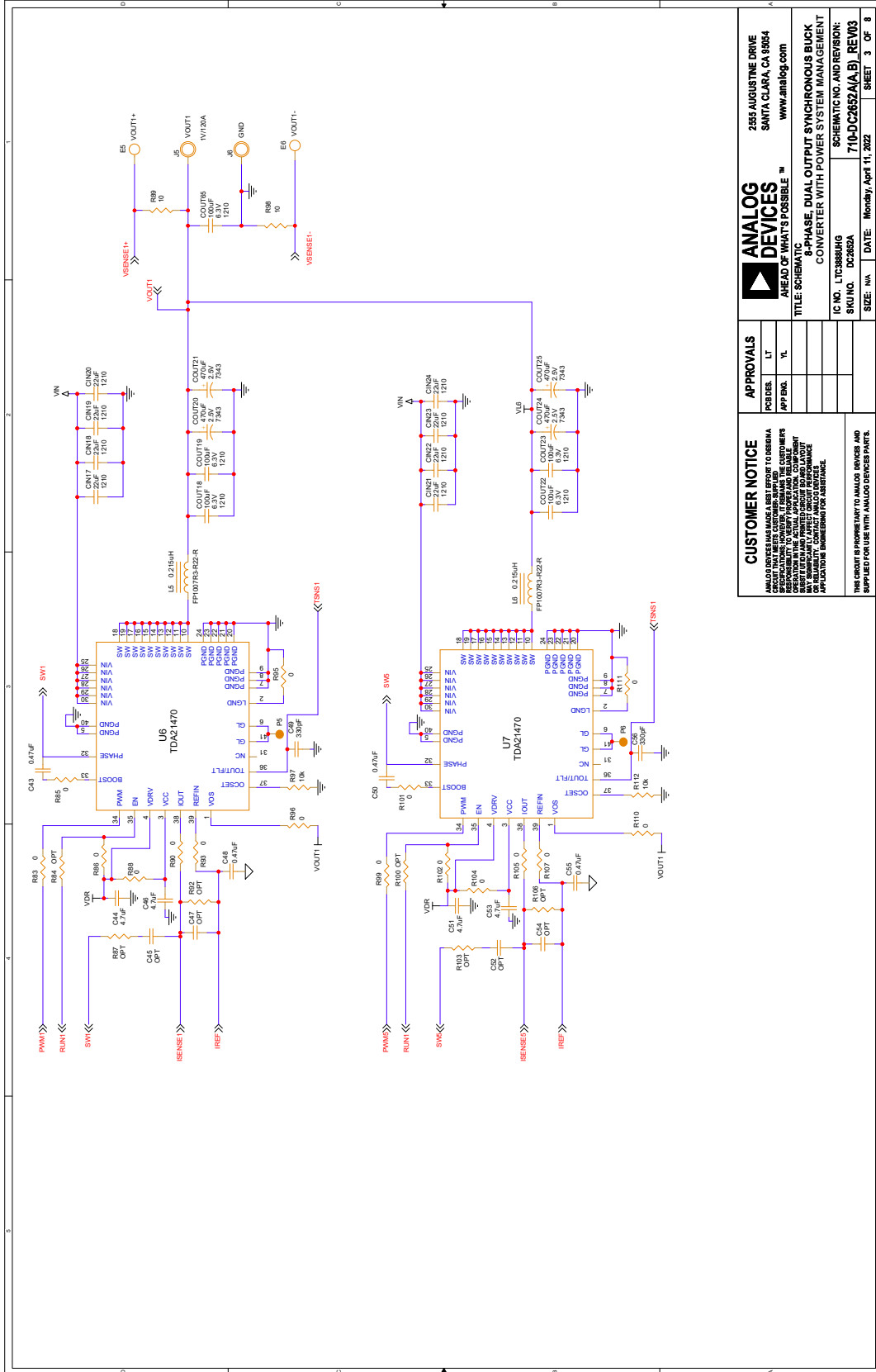

ANALOG DEVICES
 255 AUGUSTINE DRIVE
 SANTA CLARA, CA 95054
 www.analog.com

TITLE: SCHEMATIC
IC NO. LTC3888BG
CONVERTER WITH POWER SYSTEM MANAGEMENT
8-PHASE, DUAL OUTPUT SYNCHRONOUS BUCK

APPROVALS

POBDES	LT
APP ENG	YL

SKU NO. DC2652A
SCHEMATIC NO. AND REVISION: 710-DC2652A(A, B) REV03
DATE: Monday, April 11, 2022
SHEET 3 OF 8

CUSTOMER NOTICE
 ANALOG DEVICES MAKES A BEST EFFORT TO DESIGN A SCHEMATIC AND BOARD LAYOUT THAT WILL OPERATE AS SPECIFIED. HOWEVER, IT REMAINS THE CUSTOMER'S RESPONSIBILITY TO VERIFY THE SCHEMATIC AND BOARD LAYOUT IN THE ACTUAL APPLICATION. COMPONENT PARTS AND MANUFACTURING VARIATIONS MAY, SIGNIFICANTLY AFFECT CIRCUIT PERFORMANCE. APPLICATION ENGINEERING FOR ASSISTANCE.

THESE CIRCUITS REPRESENT ANALOG DEVICES AND ARE NOT INTENDED FOR USE WITH ANALOG DEVICES PARTS.

DEMO MANUAL DC2652A-A

SCHEMATIC DIAGRAM

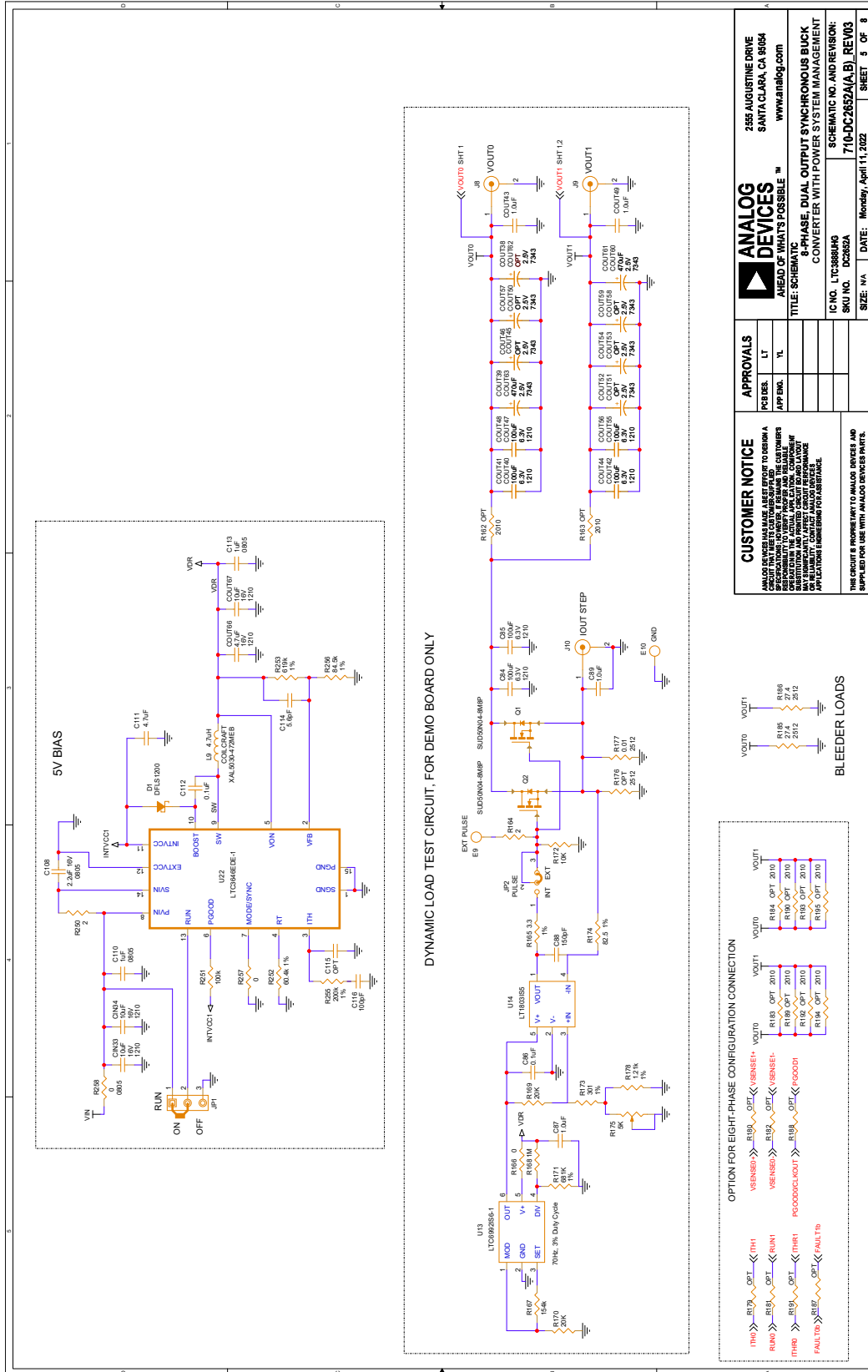

ANALOG DEVICES AHEAD OF WHAT'S POSSIBLE™		2655 AUGUSTINE DRIVE SANTA CLARA, CA 95054 www.analog.com
CUSTOMER NOTICE ANALOG DEVICES HAS THE RIGHT TO DISSEMINATE OR TO MAKE ANY PART OF THIS SCHEMATIC AVAILABLE TO ANY OTHER PARTY WITHOUT NOTICE. ANALOG DEVICES ASSUMES NO LIABILITY FOR INFRINGEMENT OF PATENTS OR OTHER INTELLECTUAL PROPERTY RIGHTS. ANALOG DEVICES ASSUMES NO LIABILITY FOR INFRINGEMENT OF PATENTS OR OTHER INTELLECTUAL PROPERTY RIGHTS.		
APPROVALS		IC NO. LTC3888HG SKU NO. DC2652A
DESIGNER	LT	SCHEMATIC NO. AND REVISION: 710-DC2652A(A,B)_REV03
APPROVER	YL	SIZE: NA
		DATE: Monday, April 11, 2022
		SHEET 5 OF 8

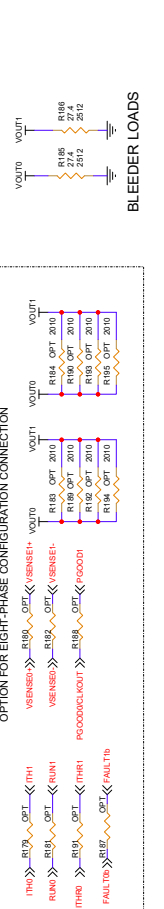

SCHEMATIC DIAGRAM

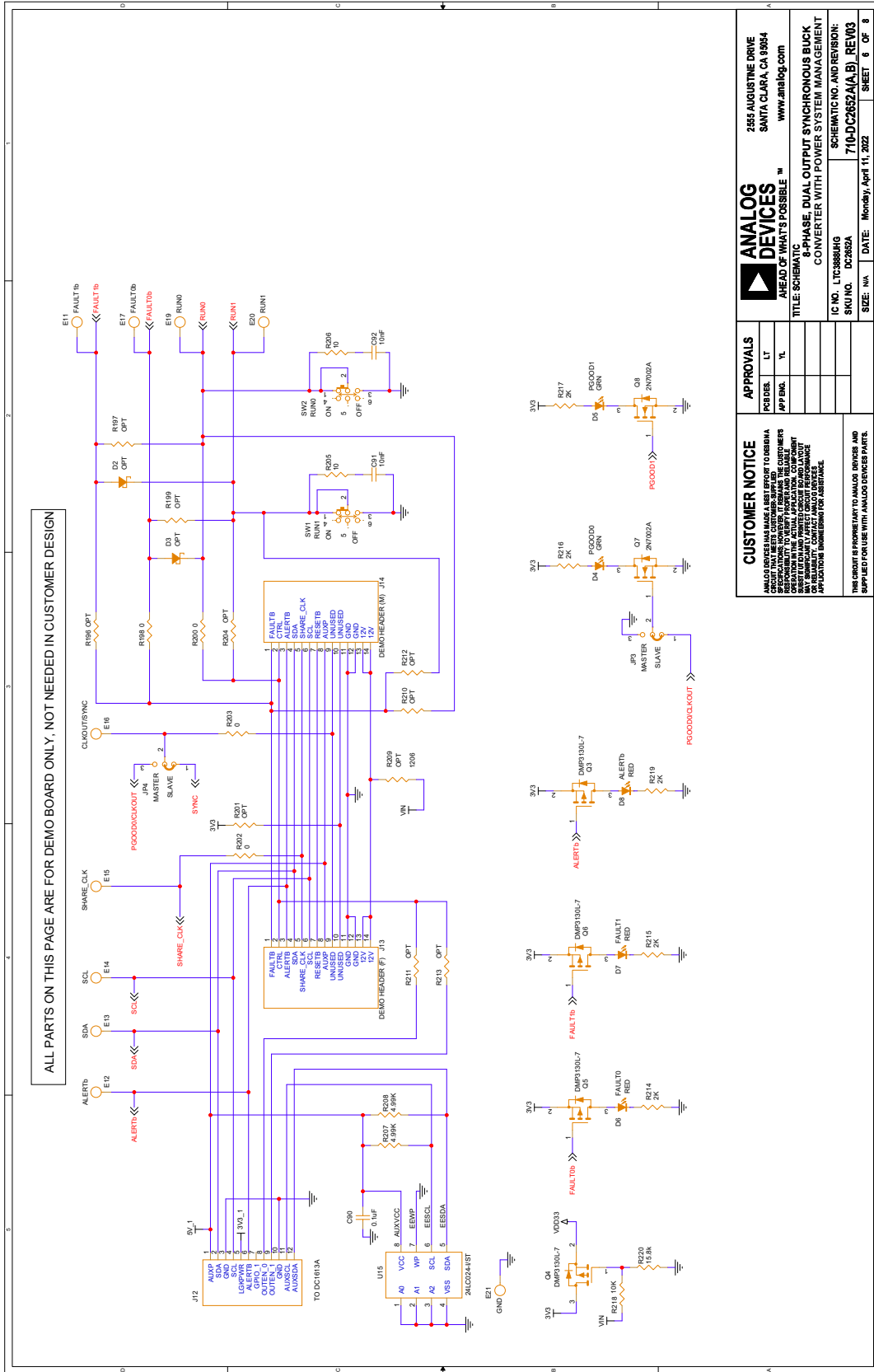

ALL PARTS ON THIS PAGE ARE FOR DEMO BOARD ONLY, NOT NEEDED IN CUSTOMER DESIGN

ANALOG DEVICES
 255 AUGUSTINE DRIVE
 SANTA CLARA, CA 95054
 www.analog.com

8-PHASE, DUAL OUTPUT SYNCHRONOUS BUCK CONVERTER WITH POWER SYSTEM MANAGEMENT

IC NO. LTC3888B
 SKU NO. DC2652A
 DATE: Monday, April 11, 2022

SCHEMATIC NO. AND REVISION:
 710-DC2652A(A, B) REV03

SIZE: 1/4" SHEET: 6 OF 8

CUSTOMER NOTICE

ANALOG DEVICES MAKES A BEST EFFORT TO DESIGN A SCHEMATIC FOR THE CUSTOMER'S APPLICATION. OPERATIONAL IN THE FIELD, THE CUSTOMER'S OPERATIONAL REQUIREMENTS, COMPONENTS, AND APPLICATIONS MAY VARY FROM THE SCHEMATIC. ANALOG DEVICES DOES NOT WARRANT THAT THE SCHEMATIC WILL BE COMPLETELY CORRECT OR THAT IT WILL BE COMPLETELY SUITABLE FOR THE CUSTOMER'S APPLICATION. CUSTOMERS ARE RESPONSIBLE FOR VERIFYING THE SCHEMATIC'S APPLICATION AND PERFORMANCE IN THEIR OWN APPLICATIONS.

APPROVALS

PCB DES.	LT
APP ENG. <td> </td>	

DESIGN RESPONSIBILITY TO ANALOG DEVICES AND APPLICABLE CUSTOMER WITH ANALOG DEVICES PARTS.

DEMO MANUAL DC2652A-A

SCHEMATIC DIAGRAM

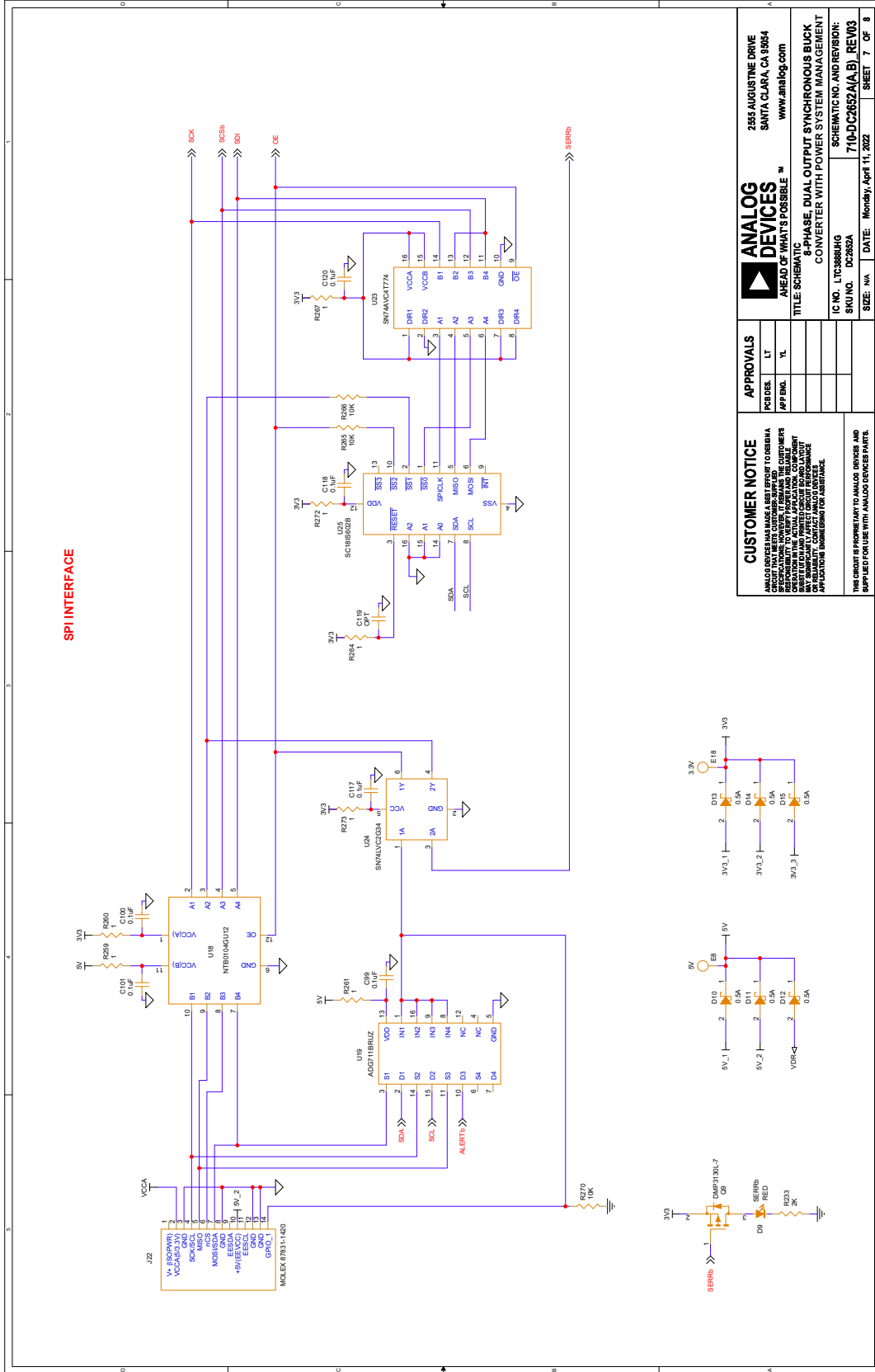

APPROVALS		255 AUGUSTINE DRIVE SANTA CLARA, CA 95054 www.analog.com	
POBDES	LT	ANALOG DEVICES AHEAD OF WHAT'S POSSIBLE™	
APP ENG	YL		
CUSTOMER NOTICE ANALOG DEVICES HAS MADE A BEST EFFORT TO DESIGN A SCHEMATIC AND BOARD FILE FOR THE CUSTOMER'S USE. OPERATIONAL PARAMETERS, INCLUDING BUT NOT LIMITED TO, OPERATIONAL TEMPERATURE, VOLTAGE, CURRENT, AND POWER, MAY VARY FROM THE ACTUAL APPLICATION. COMPONENT PERFORMANCE MAY VARY FROM THE ACTUAL APPLICATION. CUSTOMER MUST VERIFY THAT ALL COMPONENTS MEET THE SPECIFICATIONS FOR THE APPLICATION AND CONTACT APPLICATION ENGINEERING FOR ASSISTANCE.		TITLE SCHEMATIC 8-PHASE, DUAL OUTPUT SYNCHRONOUS BUCK CONVERTER WITH POWER SYSTEM MANAGEMENT	
DESIGNER'S PERMISSION TO ANALOG DEVICES AND REPEAT USE WITH ANALOG DEVICES PARTS		IC NO. LTC3888BHG	SCHEMATIC NO. AND REVISION: 710-DC2652A(A, B) REV03
SIZE: 1/8"	DATE: Monday, April 11, 2022	SKU NO. DC2652A	SHEET 7 OF 8

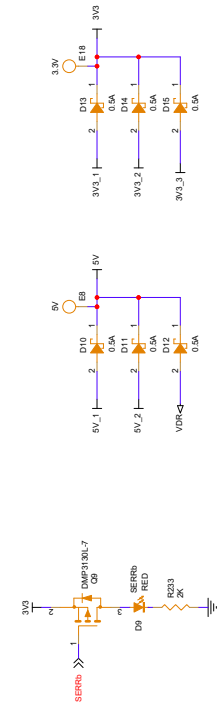

SCHEMATIC DIAGRAM

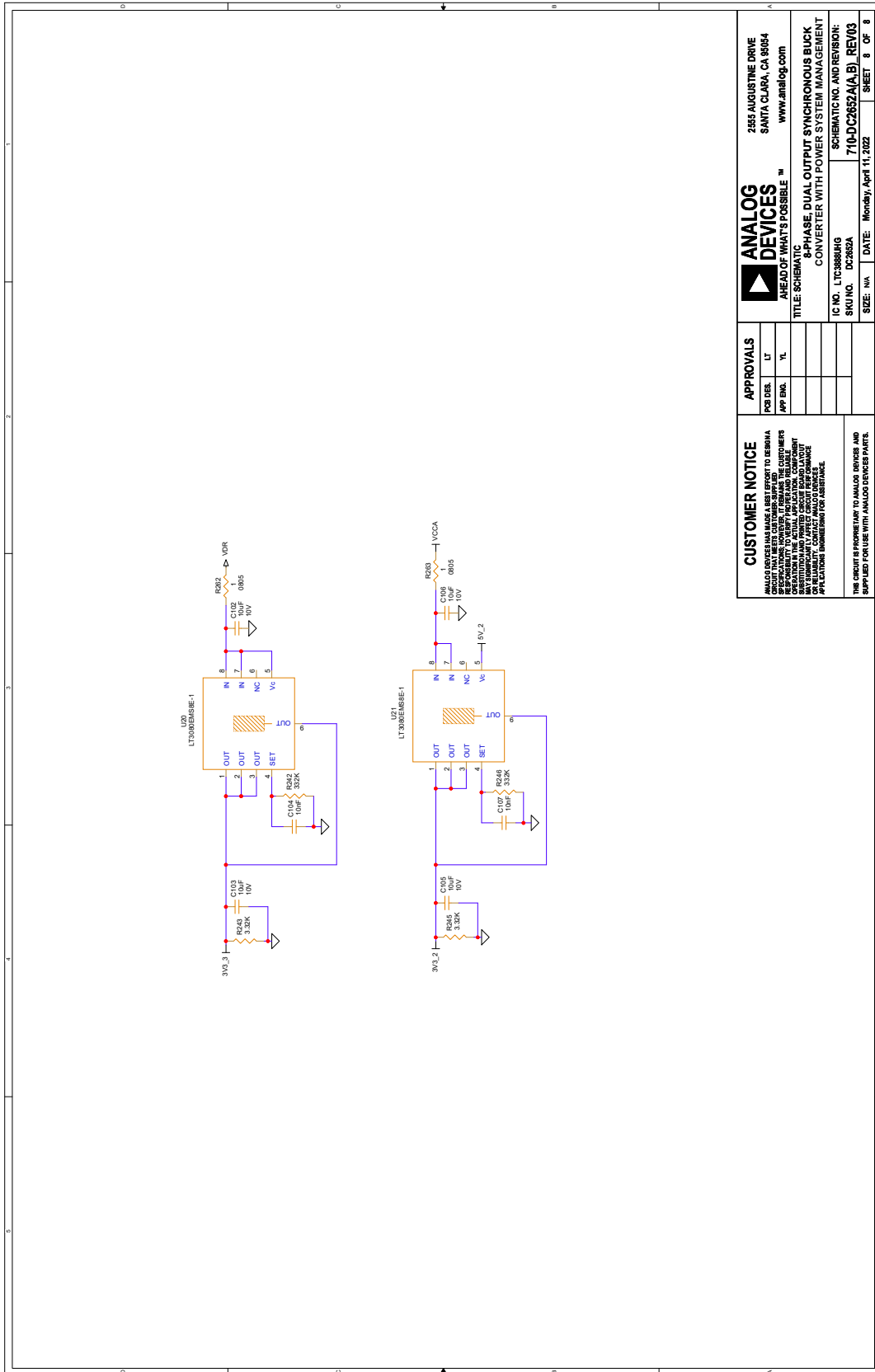

CUSTOMER NOTICE		APPROVALS	
ANALOG DEVICES MAKES A BEST EFFORT TO DESIGN SPECIFICATIONS, HOWEVER, IT REMAINS THE CUSTOMER'S RESPONSIBILITY TO VERIFY THE ACTUAL OPERATION OF THE DEVICE IN THE ACTUAL APPLICATION. CUSTOMERS ARE RESPONSIBLE FOR THE PROPER USE OF THE DEVICE IN THEIR APPLICATIONS. ANALOG DEVICES MAKES NO WARRANTY, REPRESENTATION OR APPLICATIONS, INCLUDING FOR ABUSE.		PCB DES: LT	DATE: Monday, April 11, 2022
THE CIRCUIT IS PROVIDED AS A GUIDE ONLY. ANALOG DEVICES AND SUPPLIERS ACCEPT NO LIABILITY FOR ANY DAMAGES ARISING FROM THE USE OF THIS CIRCUIT.		APP ENG: YL	SHEET 8 OF 8
ANALOG DEVICES 2355 AUGUSTINE DRIVE SANTA CLARA, CA 95054 www.analog.com		TITLE: SCHEMATIC	
IC NO. LT3802		8-PHASE, DUAL OUTPUT SYNCHRONOUS BUCK CONVERTER WITH POWER SYSTEM MANAGEMENT	
SKU NO. DC2652A		SCHEMATIC NO. AND REVISION: 710-DC2652A(A, B) REV/03	



ESD Caution

ESD (electrostatic discharge) sensitive device. Charged devices and circuit boards can discharge without detection. Although this product features patented or proprietary protection circuitry, damage may occur on devices subjected to high energy ESD. Therefore, proper ESD precautions should be taken to avoid performance degradation or loss of functionality.

Legal Terms and Conditions

By using the evaluation board discussed herein (together with any tools, components documentation or support materials, the "Evaluation Board"), you are agreeing to be bound by the terms and conditions set forth below ("Agreement") unless you have purchased the Evaluation Board, in which case the Analog Devices Standard Terms and Conditions of Sale shall govern. Do not use the Evaluation Board until you have read and agreed to the Agreement. Your use of the Evaluation Board shall signify your acceptance of the Agreement. This Agreement is made by and between you ("Customer") and Analog Devices, Inc. ("ADI"), with its principal place of business at One Technology Way, Norwood, MA 02062, USA. Subject to the terms and conditions of the Agreement, ADI hereby grants to Customer a free, limited, personal, temporary, non-exclusive, non-sublicensable, non-transferable license to use the Evaluation Board FOR EVALUATION PURPOSES ONLY. Customer understands and agrees that the Evaluation Board is provided for the sole and exclusive purpose referenced above, and agrees not to use the Evaluation Board for any other purpose. Furthermore, the license granted is expressly made subject to the following additional limitations: Customer shall not (i) rent, lease, display, sell, transfer, assign, sublicense, or distribute the Evaluation Board; and (ii) permit any Third Party to access the Evaluation Board. As used herein, the term "Third Party" includes any entity other than ADI, Customer, their employees, affiliates and in-house consultants. The Evaluation Board is NOT sold to Customer; all rights not expressly granted herein, including ownership of the Evaluation Board, are reserved by ADI. CONFIDENTIALITY. This Agreement and the Evaluation Board shall all be considered the confidential and proprietary information of ADI. Customer may not disclose or transfer any portion of the Evaluation Board to any other party for any reason. Upon discontinuation of use of the Evaluation Board or termination of this Agreement, Customer agrees to promptly return the Evaluation Board to ADI. ADDITIONAL RESTRICTIONS. Customer may not disassemble, decompile or reverse engineer chips on the Evaluation Board. Customer shall inform ADI of any occurred damages or any modifications or alterations it makes to the Evaluation Board, including but not limited to soldering or any other activity that affects the material content of the Evaluation Board. Modifications to the Evaluation Board must comply with applicable law, including but not limited to the RoHS Directive. TERMINATION. ADI may terminate this Agreement at any time upon giving written notice to Customer. Customer agrees to return to ADI the Evaluation Board at that time. LIMITATION OF LIABILITY. THE EVALUATION BOARD PROVIDED HEREUNDER IS PROVIDED "AS IS" AND ADI MAKES NO WARRANTIES OR REPRESENTATIONS OF ANY KIND WITH RESPECT TO IT. ADI SPECIFICALLY DISCLAIMS ANY REPRESENTATIONS, ENDORSEMENTS, GUARANTEES, OR WARRANTIES, EXPRESS OR IMPLIED, RELATED TO THE EVALUATION BOARD INCLUDING, BUT NOT LIMITED TO, THE IMPLIED WARRANTY OF MERCHANTABILITY, TITLE, FITNESS FOR A PARTICULAR PURPOSE OR NON-INFRINGEMENT OF INTELLECTUAL PROPERTY RIGHTS. IN NO EVENT WILL ADI AND ITS LICENSORS BE LIABLE FOR ANY INCIDENTAL, SPECIAL, INDIRECT, OR CONSEQUENTIAL DAMAGES RESULTING FROM CUSTOMER'S POSSESSION OR USE OF THE EVALUATION BOARD, INCLUDING BUT NOT LIMITED TO LOST PROFITS, DELAY COSTS, LABOR COSTS OR LOSS OF GOODWILL. ADI'S TOTAL LIABILITY FROM ANY AND ALL CAUSES SHALL BE LIMITED TO THE AMOUNT OF ONE HUNDRED US DOLLARS (\$100.00). EXPORT. Customer agrees that it will not directly or indirectly export the Evaluation Board to another country, and that it will comply with all applicable United States federal laws and regulations relating to exports. GOVERNING LAW. This Agreement shall be governed by and construed in accordance with the substantive laws of the Commonwealth of Massachusetts (excluding conflict of law rules). Any legal action regarding this Agreement will be heard in the state or federal courts having jurisdiction in Suffolk County, Massachusetts, and Customer hereby submits to the personal jurisdiction and venue of such courts. The United Nations Convention on Contracts for the International Sale of Goods shall not apply to this Agreement and is expressly disclaimed.