

<IGBT Modules>

CM100RX-12A

HIGH POWER SWITCHING USE
INSULATED TYPE



sevenpack (3φ Inverter + Brake Chopper)

Collector current I_C 1 0 0 A
 Collector-emitter voltage V_{CES} 6 0 0 V
 Maximum junction temperature T_{jmax} 1 5 0 °C

- Flat base Type
- Copper base plate (non-plating)
- RoHS Directive compliant
- Recognized under UL1557, File E323585

APPLICATION

AC Motor Control, Motion/Servo Control, etc.

OUTLINE DRAWING & INTERNAL CONNECTION

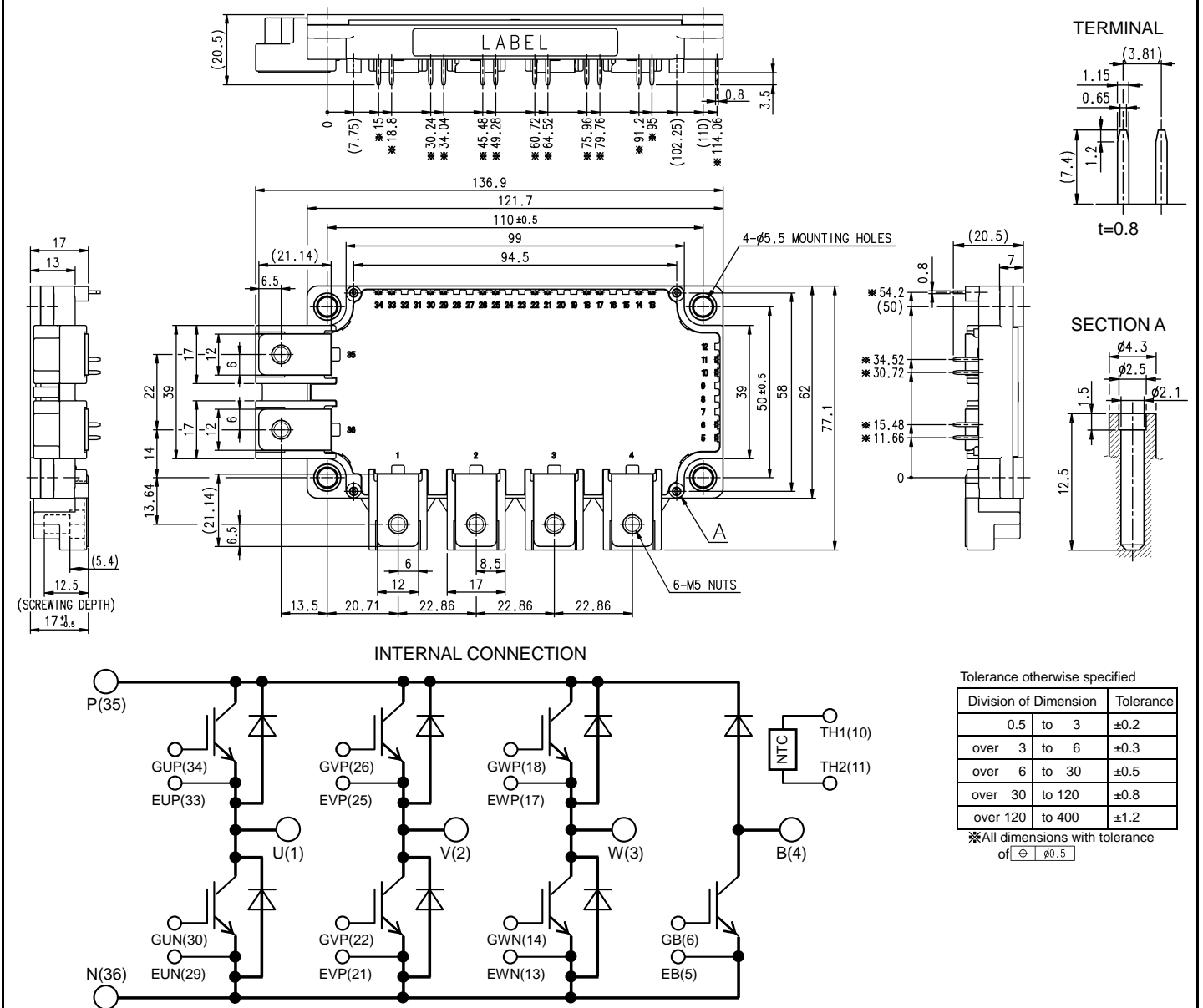

Tolerance otherwise specified

Division of Dimension	Tolerance
0.5 to 3	±0.2
over 3 to 6	±0.3
over 6 to 30	±0.5
over 30 to 120	±0.8
over 120 to 400	±1.2

※All dimensions with tolerance of ± 0.5

CM100RX-12AHIGH POWER SWITCHING USE
INSULATED TYPEMAXIMUM RATINGS ($T_J=25\text{ }^\circ\text{C}$, unless otherwise specified)

INVERTER PART IGBT/DIODE

Symbol	Item	Conditions	Rating	Unit
V_{CES}	Collector-emitter voltage	G-E short-circuited	600	V
V_{GES}	Gate-emitter voltage	C-E short-circuited	± 20	V
I_C	Collector current	DC, $T_C=75\text{ }^\circ\text{C}$ (Note2, 4)	100	A
I_{CRM}		Pulse, Repetitive (Note3)	200	
P_{tot}	Total power dissipation	$T_C=25\text{ }^\circ\text{C}$ (Note2, 4)	400	W
I_E (Note1)	Emitter current	DC (Note2)	100	A
I_{ERM} (Note1)		Pulse, Repetitive (Note3)	200	

BRAKE PART IGBT/DIODE

Symbol	Item	Conditions	Rating	Unit
V_{CES}	Collector-emitter voltage	G-E short-circuited	600	V
V_{GES}	Gate-emitter voltage	C-E short-circuited	± 20	V
I_C	Collector current	DC, $T_C=97\text{ }^\circ\text{C}$ (Note2, 4)	50	A
I_{CRM}		Pulse, Repetitive (Note3)	100	
P_{tot}	Total power dissipation	$T_C=25\text{ }^\circ\text{C}$ (Note2, 4)	280	W
V_{RRM}	Repetitive peak reverse voltage	G-E short-circuited	600	V
I_F	Forward current	DC (Note2)	50	A
I_{FRM}		Pulse, Repetitive (Note3)	100	

MODULE

Symbol	Item	Conditions	Rating	Unit
V_{isol}	Isolation voltage	Terminals to base plate, RMS, $f=60\text{ Hz}$, AC 1 min	2500	V
T_J	Junction temperature	-	-40 ~ +150	$^\circ\text{C}$
T_{stg}	Storage temperature	-	-40 ~ +125	
T_{Cmax}	Maximum case temperature	(Note4)	125	$^\circ\text{C}$

ELECTRICAL CHARACTERISTICS ($T_J=25\text{ }^\circ\text{C}$, unless otherwise specified)

INVERTER PART IGBT/DIODE

Symbol	Item	Conditions	Limits			Unit
			Min.	Typ.	Max.	
I_{CES}	Collector-emitter cut-off current	$V_{CE}=V_{CES}$, G-E short-circuited	-	-	1.0	mA
I_{GES}	Gate-emitter leakage current	$V_{GE}=V_{GES}$, C-E short-circuited	-	-	0.5	μA
$V_{GE(th)}$	Gate-emitter threshold voltage	$I_C=10\text{ mA}$, $V_{CE}=10\text{ V}$	5	6	7	V
V_{CEsat}	Collector-emitter saturation voltage	$I_C=100\text{ A}$, $V_{GE}=15\text{ V}$ (Note5)	-	1.7	2.1	V
		Refer to the figure of test circuit				
		$I_C=100\text{ A}$, $V_{GE}=15\text{ V}$, chip (Note5)	-	1.6	-	
C_{ies}	Input capacitance	$V_{CE}=10\text{ V}$, G-E short-circuited	-	-	13.3	nF
C_{oes}	Output capacitance		-	-	1.4	
C_{res}	Reverse transfer capacitance		-	-	0.45	
Q_G	Gate charge		$V_{CC}=300\text{ V}$, $I_C=100\text{ A}$, $V_{GE}=15\text{ V}$	-	270	
$t_{d(on)}$	Turn-on delay time	$V_{CC}=300\text{ V}$, $I_C=100\text{ A}$, $V_{GE}=\pm 15\text{ V}$, $R_G=6.2\text{ }\Omega$, Inductive load	-	-	100	ns
t_r	Rise time		-	-	100	
$t_{d(off)}$	Turn-off delay time		-	-	300	
t_f	Fall time		-	-	600	
r_g	Internal gate resistance	Per switch	-	0	-	Ω

CM100RX-12A

HIGH POWER SWITCHING USE
INSULATED TYPEELECTRICAL CHARACTERISTICS (cont.; T_j=25 °C, unless otherwise specified)
INVERTER PART IGBT/DIODE

Symbol	Item	Conditions	Limits			Unit	
			Min.	Typ.	Max.		
V _{EC} (Note1)	Emitter-collector voltage	I _E =100 A, G-E short-circuited (Note5)	T _j =25 °C	-	2.0	2.8	V
		Refer to the figure of test circuit		T _j =125 °C	-	1.95	
		I _E =100 A, G-E short-circuited, chip (Note5)	-	1.9	-		
t _{rr} (Note1)	Reverse recovery time	V _{CC} =300 V, I _E =100 A, V _{GE} =±15 V,	-	-	200	ns	
Q _{rr} (Note1)	Reverse recovery charge	R _G =6.2 Ω, Inductive load	-	3.6	-	μC	
E _{on}	Turn-on switching energy per pulse	V _{CC} =300 V, I _C =I _E =100 A,	-	1.6	-	mJ	
E _{off}	Turn-off switching energy per pulse	V _{GE} =±15 V, R _G =6.2 Ω, T _j =125 °C,	-	5.2	-		
E _{rr} (Note1)	Reverse recovery energy per pulse	Inductive load	-	1.1	-	mJ	

BRAKE PART IGBT/DIODE

Symbol	Item	Conditions	Limits			Unit	
			Min.	Typ.	Max.		
I _{CES}	Collector-emitter cut-off current	V _{CE} =V _{CES} , G-E short-circuited	-	-	1.0	mA	
I _{GES}	Gate-emitter leakage current	V _{GE} =V _{GES} , C-E short-circuited	-	-	0.5	μA	
V _{GE(th)}	Gate-emitter threshold voltage	I _C =5 mA, V _{CE} =10 V	5	6	7	V	
V _{CESat}	Collector-emitter saturation voltage	I _C =50 A, V _{GE} =15 V (Note5)	T _j =25 °C	-	1.7	2.1	V
		Refer to the figure of test circuit		T _j =125 °C	-	1.9	
		I _C =50 A, V _{GE} =15 V, chip (Note5)	-	1.6	-		
C _{ies}	Input capacitance	V _{CE} =10 V, G-E short-circuited	-	-	9.3	nF	
C _{oes}	Output capacitance		-	-	1.0		
C _{res}	Reverse transfer capacitance		-	-	0.3		
Q _G	Gate charge	V _{CC} =300 V, I _C =50 A, V _{GE} =15 V	-	200	-	nC	
I _{RRM}	Repetitive peak reverse current	V _R =V _{RRM} , G-E short-circuited	-	-	1.0	mA	
V _F	Forward voltage	I _F =50 A, G-E short-circuited (Note5)	T _j =25 °C	-	2.0	2.8	V
		Refer to the figure of test circuit		T _j =125 °C	-	1.95	
		I _F =50 A, G-E short-circuited, chip (Note5)	-	1.9	-		
r _g	Internal gate resistance	-	-	0	-	Ω	

NTC THERMISTOR PART

Symbol	Item	Conditions	Limits			Unit
			Min.	Typ.	Max.	
R ₂₅	Zero-power resistance	T _C =25 °C (Note4)	4.85	5.00	5.15	kΩ
ΔR/R	Deviation of resistance	R ₁₀₀ =493 Ω, T _C =100 °C (Note4)	-7.3	-	+7.8	%
B _(25/50)	B-constant	Approximate by equation (Note6)	-	3375	-	K
P ₂₅	Power dissipation	T _C =25 °C (Note4)	-	-	10	mW

THERMAL RESISTANCE CHARACTERISTICS

Symbol	Item	Conditions	Limits			Unit
			Min.	Typ.	Max.	
R _{th(j-c)Q}	Thermal resistance	Junction to case, per Inverter IGBT (Note4)	-	-	0.31	K/W
R _{th(j-c)D}		Junction to case, per Inverter DIODE (Note4)	-	-	0.59	
R _{th(j-c)Q}		Junction to case, Brake IGBT (Note4)	-	-	0.44	K/W
R _{th(j-c)D}		Junction to case, Brake DIODE (Note4)	-	-	0.85	
R _{th(c-s)}	Contact thermal resistance	Case to heat sink, per 1 module, Thermal grease applied (Note4, 7)	-	15	-	K/kW

CM100RX-12A

HIGH POWER SWITCHING USE
INSULATED TYPE

MECHANICAL CHARACTERISTICS

Symbol	Item	Conditions	Limits			Unit
			Min.	Typ.	Max.	
M _t	Mounting torque	Main terminals M 5 screw	2.5	3.0	3.5	N·m
M _s	Mounting torque	Mounting to heat sink M 5 screw	2.5	3.0	3.5	N·m
d _s	Creepage distance	Terminal to terminal	10.28	-	-	mm
		Terminal to base plate	12.46	-	-	
d _a	Clearance	Terminal to terminal	9.88	-	-	mm
		Terminal to base plate	10.12	-	-	
m	mass	-	-	350	-	g
e _c	Flatness of base plate	On the centerline X, Y (Note8)	±0	-	+100	µm

Note1. Represent ratings and characteristics of the anti-parallel, emitter-collector free wheeling diode (DIODE).

- Junction temperature (T_j) should not increase beyond T_{jmax} rating.
- Pulse width and repetition rate should be such that the device junction temperature (T_j) dose not exceed T_{jmax} rating.
- Case temperature (T_c) and heat sink temperature (T_s) are defined on the each surface (mounting side) of base plate and heat sink just under the chips. Refer to the figure of chip location.
- Pulse width and repetition rate should be such as to cause negligible temperature rise.

$$6. B_{(25/50)} = \ln\left(\frac{R_{25}}{R_{50}}\right) / \left(\frac{1}{T_{25}} - \frac{1}{T_{50}}\right),$$

R₂₅: resistance at absolute temperature T₂₅ [K]; T₂₅=25 [°C]+273.15=298.15 [K]

R₅₀: resistance at absolute temperature T₅₀ [K]; T₅₀=50 [°C]+273.15=323.15 [K]

7. Typical value is measured by using thermally conductive grease of λ=0.9 W/(m·K).

8. The base plate (mounting side) flatness measurement points (X, Y) are as follows of the following figure.

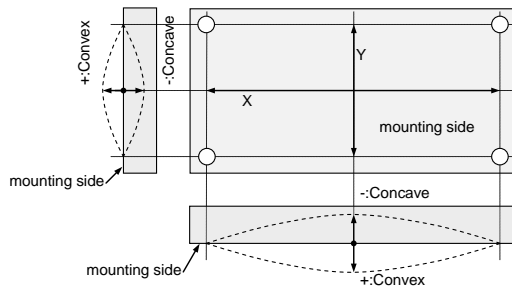

- Use the following screws when mounting the printed circuit board (PCB) on the standoffs.
"φ2.3×10 or φ2.3×12, B1 tapping screw"
The length of the screw depends on the thickness (t1.6~t2.0) of the PCB.

RECOMMENDED OPERATING CONDITIONS

Symbol	Item	Conditions	Limits			Unit	
			Min.	Typ.	Max.		
V _{CC}	(DC) Supply voltage	Applied across P-N terminals	-	300	400	V	
V _{GEon}	Gate (-emitter drive) voltage	Applied across GB-EB / G*P-E*P / G*N-E*N (*=U, V, W) terminals	13.5	15.0	16.5	V	
R _G	External gate resistance	Per switch	Inverter IGBT	6.0	-	62	Ω
			Brake IGBT	13	-	125	

CM100RX-12A

HIGH POWER SWITCHING USE
INSULATED TYPE

CHIP LOCATION (Top view)

Dimension in mm, tolerance: ±1 mm

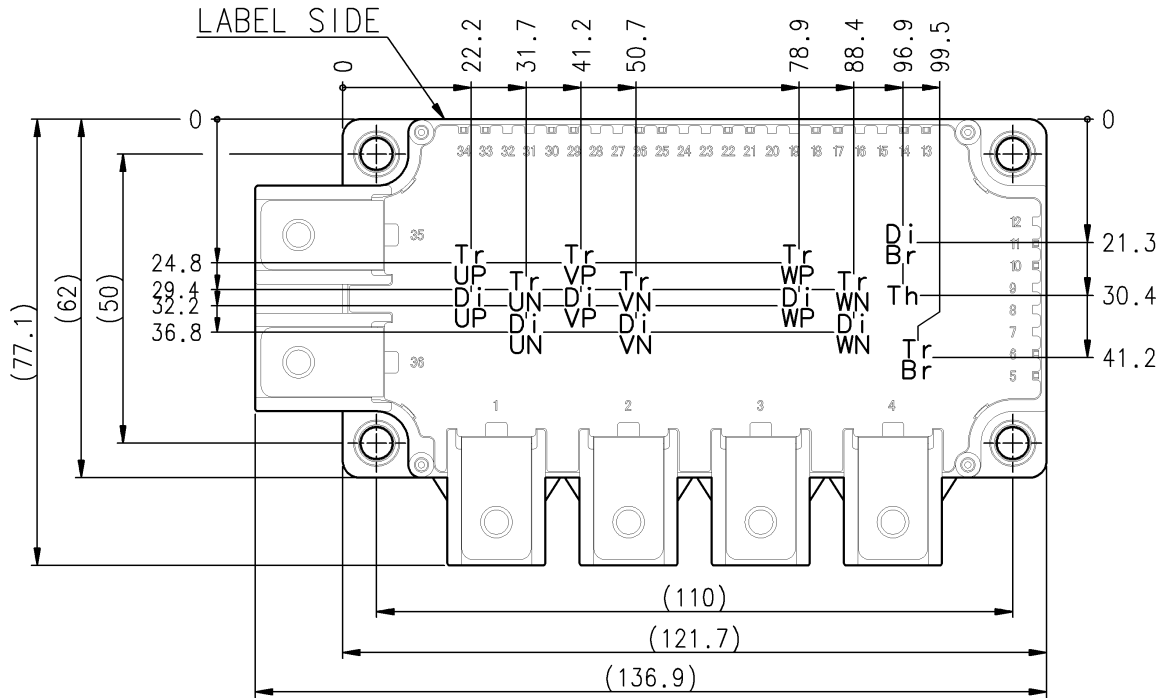

Tr*P/Tr*N/TrBr: IGBT, Di*P/Di*N: DIODE (*=U/V/W), DiBr: BRAKE DIODE, Th: NTC thermistor

TEST CIRCUIT AND WAVEFORMS

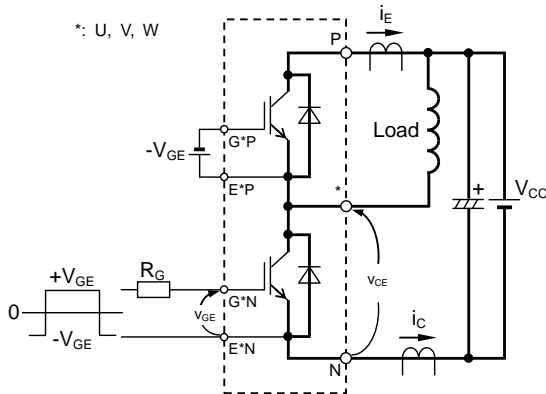

Switching test circuit and waveforms (ex. lower arm switching)

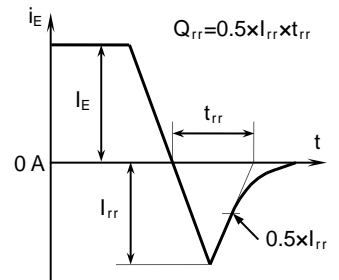
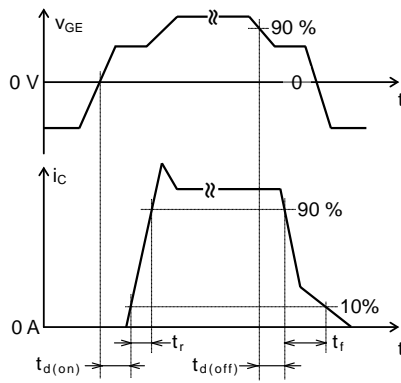

t_{rr} , Q_{rr} test waveform

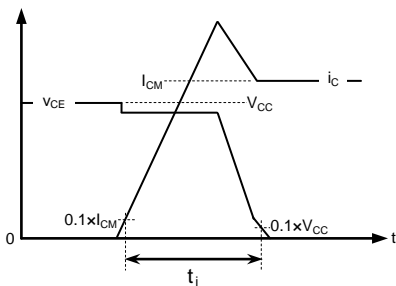

IGBT Turn-on switching energy

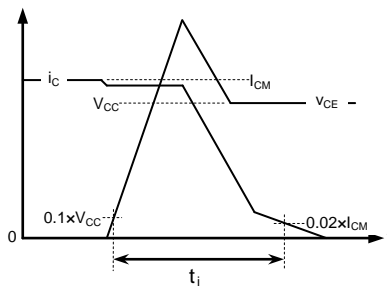

IGBT Turn-off switching energy

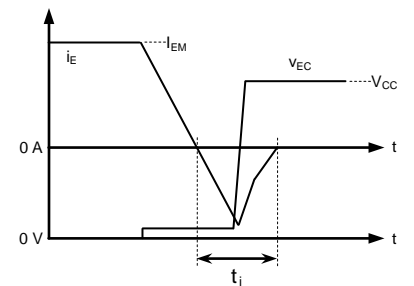

DIODE Reverse recovery energy

Turn-on / Turn-off switching energy and Reverse recovery energy test waveforms (Integral time instruction drawing)

CM100RX-12A

HIGH POWER SWITCHING USE
INSULATED TYPE

TEST CIRCUIT

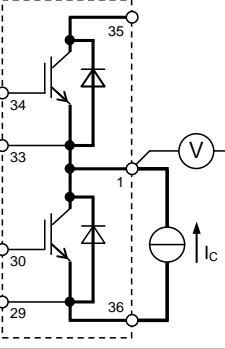
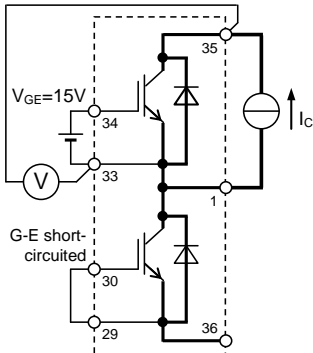

Gate-emitter GVP-EVP, GVN-EVN, short-circuited GWP-EWP, GWN-EWN, GB-EB

UP / UN IGBT

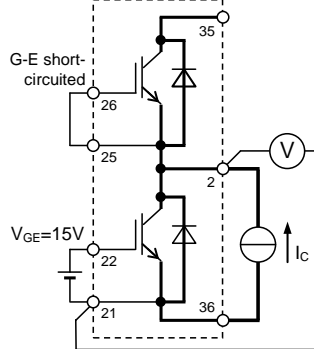
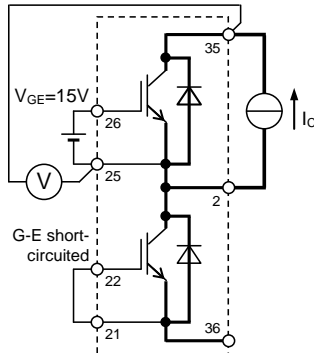

Gate-emitter GUP-EUP, GUN-EUN, short-circuited GWP-EWP, GWN-EWN, GB-EB

VP / VN IGBT

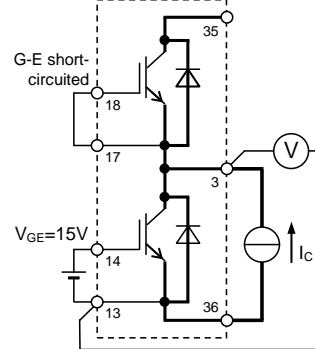
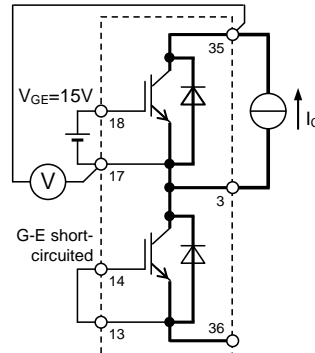

Gate-emitter GUP-EUP, GUN-EUN, short-circuited GVP-EVP, GVN-EVN, GWP-EWP, GWN-EWN, GB-EB

Brake IGBT

V_{CEsat} characteristics test circuit

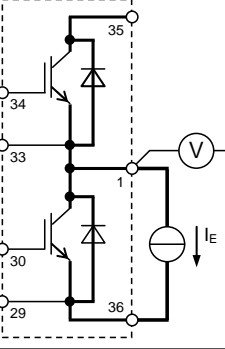
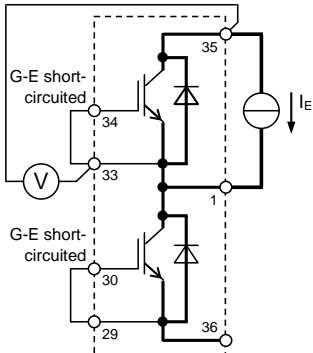

Gate-emitter GVP-EVP, GVN-EVN, short-circuited GWP-EWP, GWN-EWN, GB-EB

UP / UN DIODE

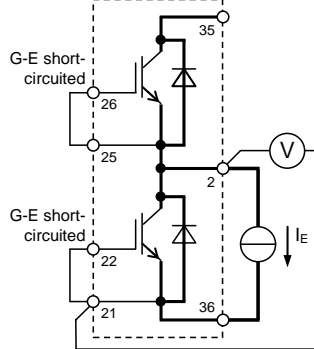
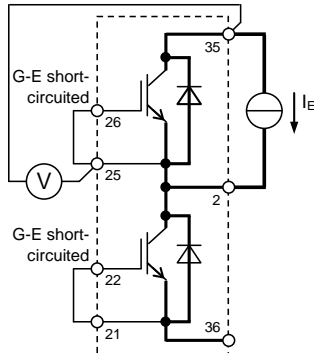

Gate-emitter GUP-EUP, GUN-EUN, short-circuited GWP-EWP, GWN-EWN, GB-EB

VP / VN DIODE

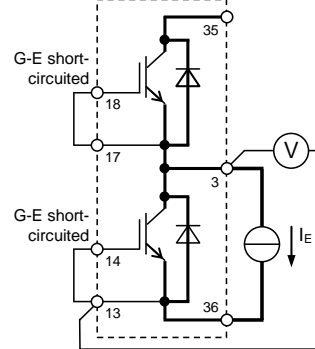
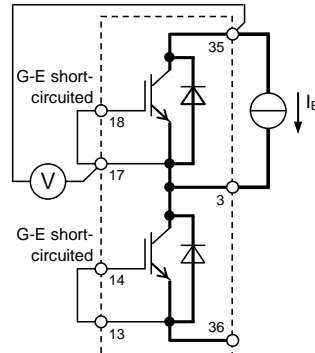

Gate-emitter GUP-EUP, GUN-EUN, short-circuited GVP-EVP, GVN-EVN, GWP-EWP, GWN-EWN

Brake DIODE

V_{EC} / Brake diode V_f characteristics test circuit

CM100RX-12A

HIGH POWER SWITCHING USE
INSULATED TYPE

PERFORMANCE CURVES

INVERTER PART

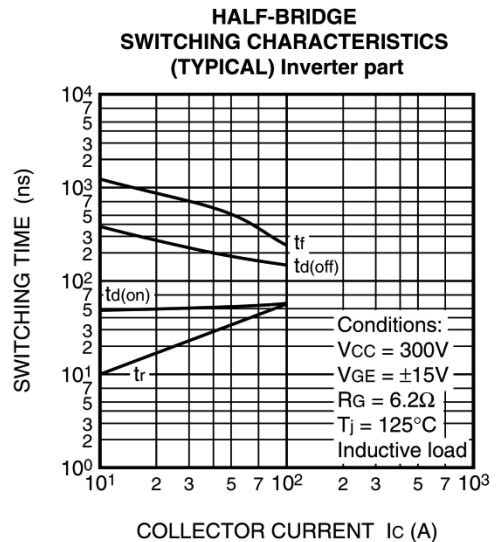
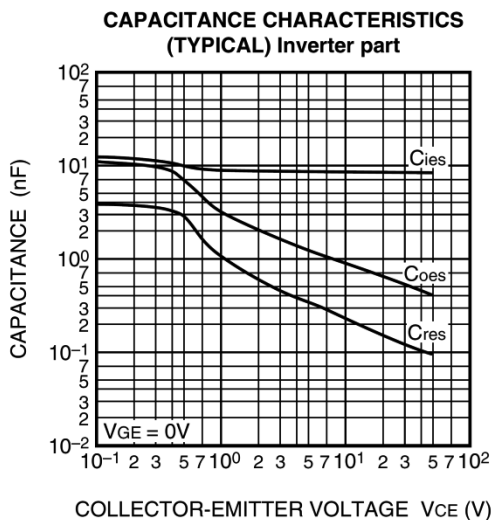
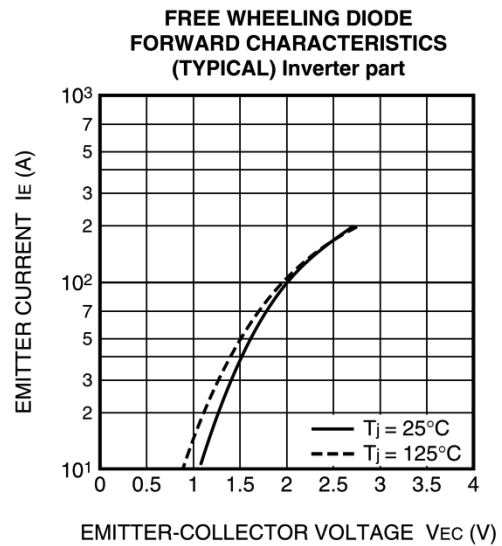
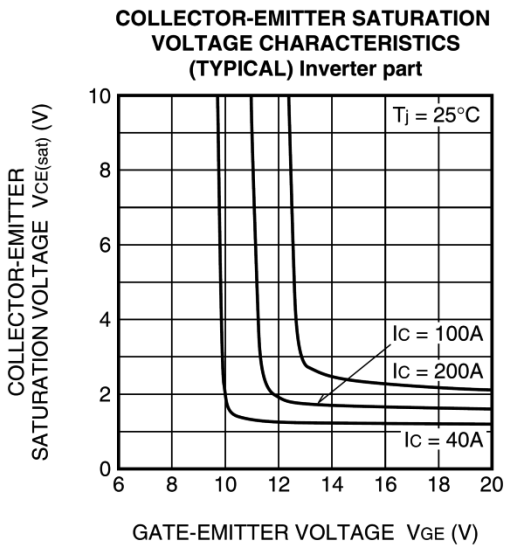
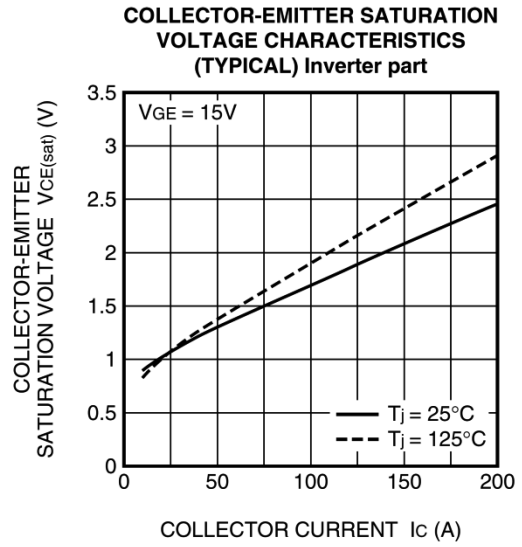
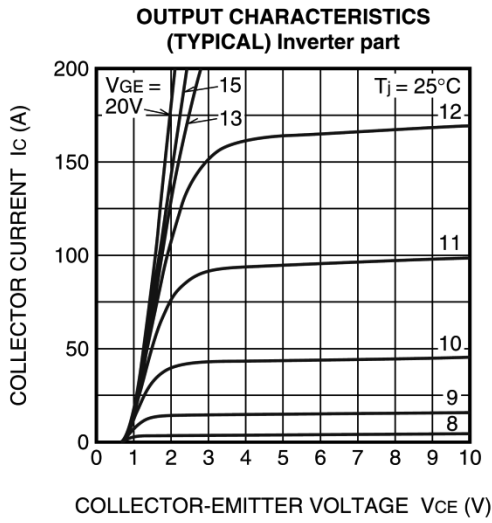

CM100RX-12A

HIGH POWER SWITCHING USE
INSULATED TYPE

PERFORMANCE CURVES

INVERTER PART

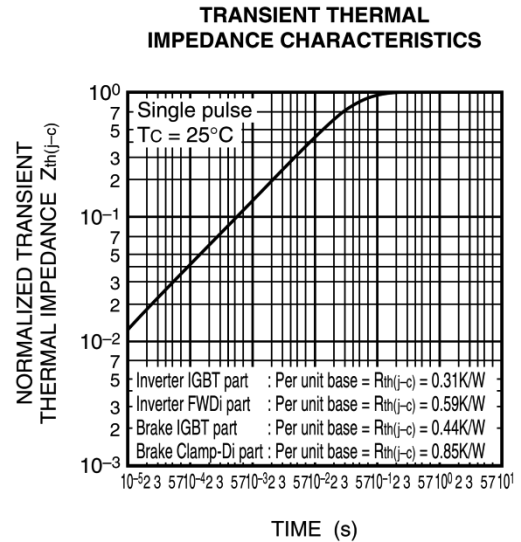
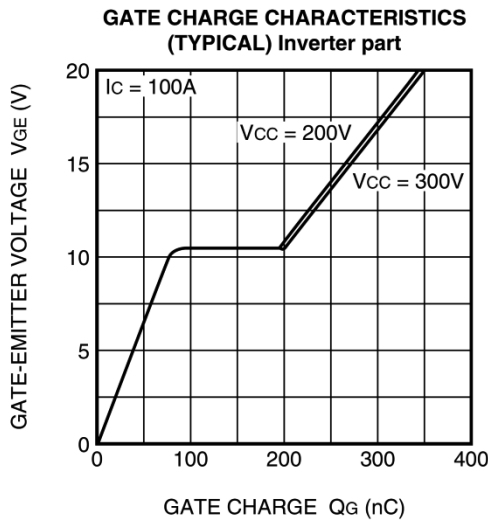
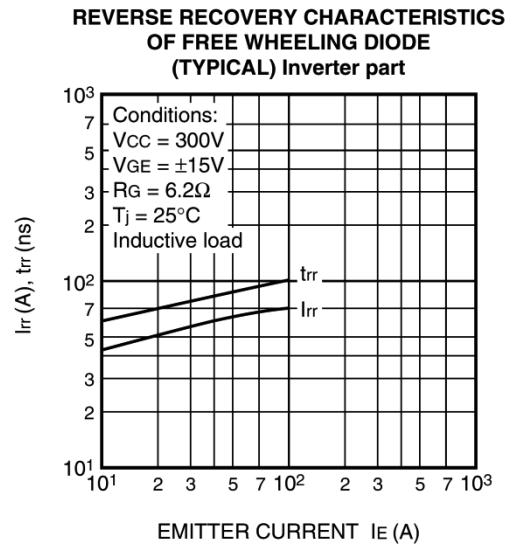
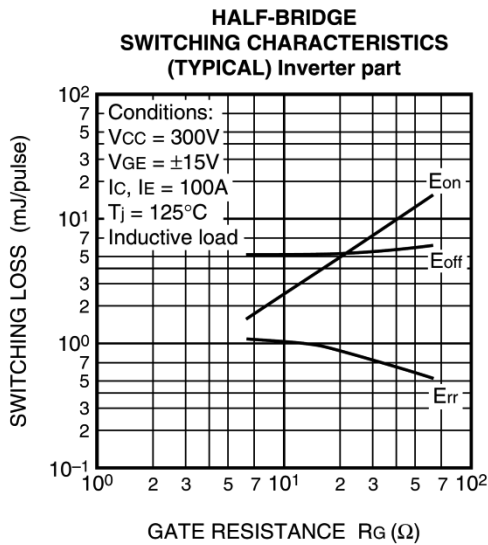
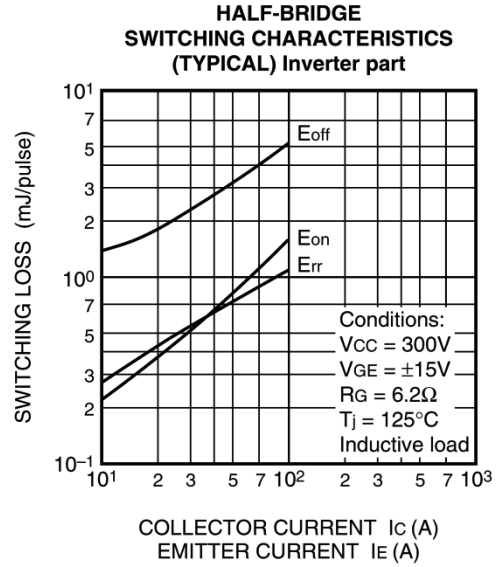
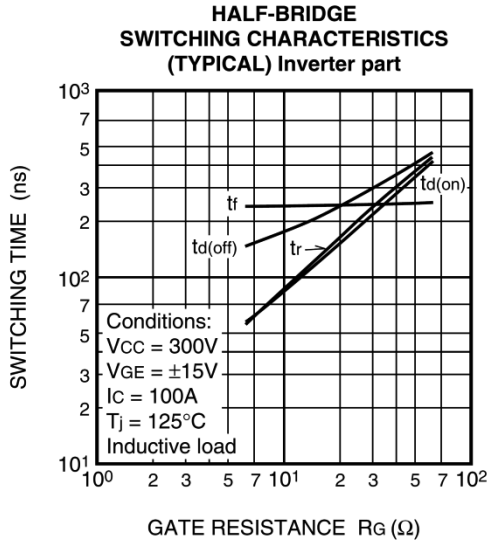

CM100RX-12A

HIGH POWER SWITCHING USE
INSULATED TYPE

PERFORMANCE CURVES

BRAKE PART

COLLECTOR-EMITTER SATURATION VOLTAGE CHARACTERISTICS (TYPICAL) Brake part

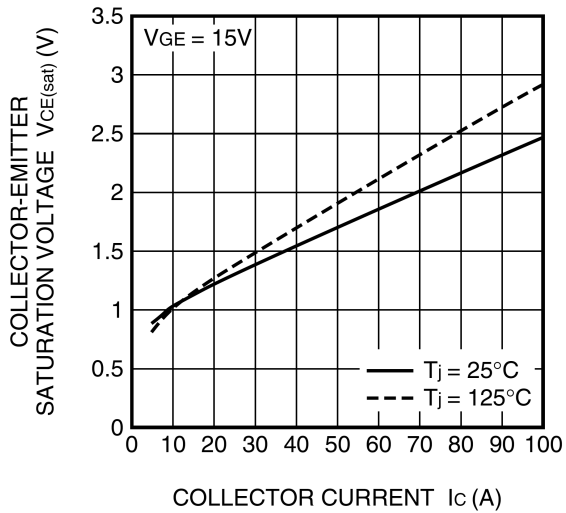

CLAMP DIODE FORWARD CHARACTERISTICS (TYPICAL) Brake part

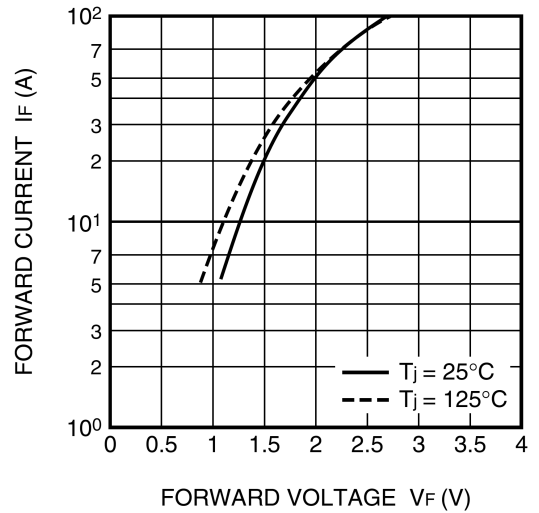

NTC thermistor part

TEMPERATURE CHARACTERISTICS (TYPICAL)

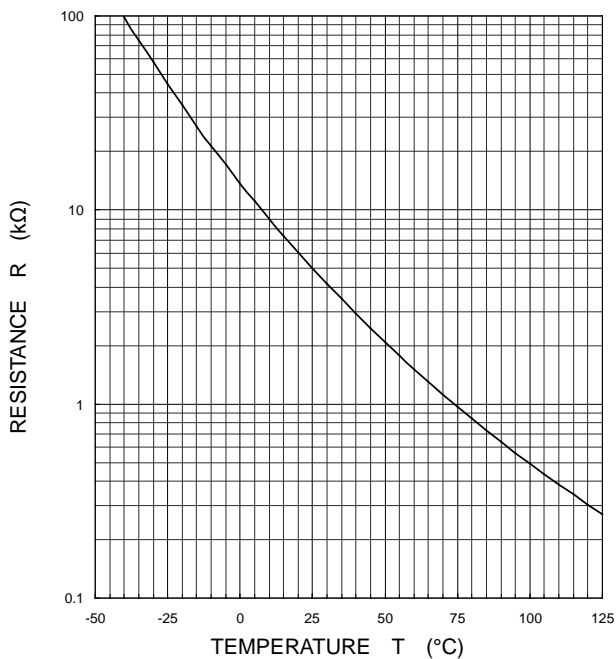

Keep safety first in your circuit designs!

Mitsubishi Electric Corporation puts the maximum effort into making semiconductor products better and more reliable, but there is always the possibility that trouble may occur with them. Trouble with semiconductors may lead to personal injury, fire or property damage. Remember to give due consideration to safety when making your circuit designs, with appropriate measures such as (i) placement of substitutive, auxiliary circuits, (ii) use of non-flammable material or (iii) prevention against any malfunction or mishap.

Notes regarding these materials

- These materials are intended as a reference to assist our customers in the selection of the Mitsubishi semiconductor product best suited to the customer's application; they do not convey any license under any intellectual property rights, or any other rights, belonging to Mitsubishi Electric Corporation or a third party.
- Mitsubishi Electric Corporation assumes no responsibility for any damage, or infringement of any third-party's rights, originating in the use of any product data, diagrams, charts, programs, algorithms, or circuit application examples contained in these materials.
- All information contained in these materials, including product data, diagrams, charts, programs and algorithms represents information on products at the time of publication of these materials, and are subject to change by Mitsubishi Electric Corporation without notice due to product improvements or other reasons. It is therefore recommended that customers contact Mitsubishi Electric Corporation or an authorized Mitsubishi Semiconductor product distributor for the latest product information before purchasing a product listed herein.
The information described here may contain technical inaccuracies or typographical errors. Mitsubishi Electric Corporation assumes no responsibility for any damage, liability, or other loss rising from these inaccuracies or errors.
Please also pay attention to information published by Mitsubishi Electric Corporation by various means, including the Mitsubishi Semiconductor home page (www.MitsubishiElectric.com/semiconductors/).
- When using any or all of the information contained in these materials, including product data, diagrams, charts, programs, and algorithms, please be sure to evaluate all information as a total system before making a final decision on the applicability of the information and products. Mitsubishi Electric Corporation assumes no responsibility for any damage, liability or other loss resulting from the information contained herein.
- Mitsubishi Electric Corporation semiconductors are not designed or manufactured for use in a device or system that is used under circumstances in which human life is potentially at stake. Please contact Mitsubishi Electric Corporation or an authorized Mitsubishi Semiconductor product distributor when considering the use of a product contained herein for any specific purposes, such as apparatus or systems for transportation, vehicular, medical, aerospace, nuclear, or undersea repeater use.
- The prior written approval of Mitsubishi Electric Corporation is necessary to reprint or reproduce in whole or in part these materials.
- If these products or technologies are subject to the Japanese export control restrictions, they must be exported under a license from the Japanese government and cannot be imported into a country other than the approved destination.
Any diversion or reexport contrary to the export control laws and regulations of Japan and/or the country of destination is prohibited.
- Please contact Mitsubishi Electric Corporation or an authorized Mitsubishi Semiconductor product distributor for further details on these materials or the products contained therein.