

# SERPAC 151R2AA (exploded isometric)

Electronic Enclosures

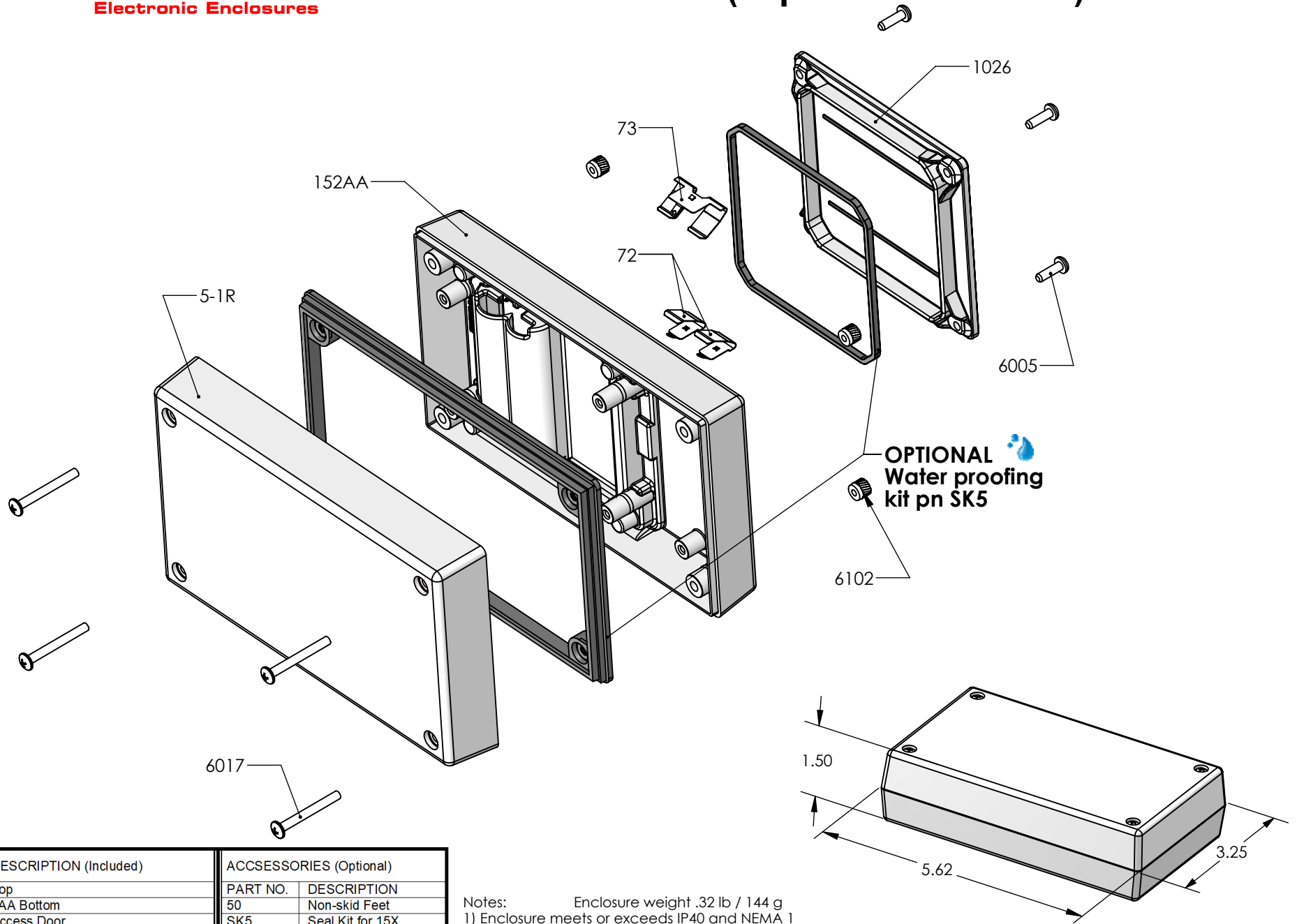

**OPTIONAL**  
Water proofing  
kit pn SK5

PART NO.	DESCRIPTION (Included)	ACCESSORIES (Optional)
5-1R	Top	
152AA	2AA Bottom	
1026	Access Door	
6005	#4X3/8" Self-Tapping Screw (4)	
6017	4-40 Screw (4)	
6102	4-40 Threaded Insert (4)	
73	Double Battery Contact (3)	
72	Single Battery Contact (2)	
		PART NO. DESCRIPTION
		50 Non-skid Feet
		SK5 Seal Kit for 15X

- Notes:
- 1) Enclosure weight .32 lb / 144 g
  - 2) Enclosure meets or exceeds IP40 and NEMA 1
  - 3) When used with SK5 the enclosure meets or exceeds IP 67 and NEMA 4X, 12 and 13 MIL-STD-810G 506.5 (.02 lb / 11g)
  - 4) Circuit Board drawings see sheet 3.
  - 5) All components are RoHS Compliant.



# SERPAC PCB for 15X compartment enclosures

Electronic Enclosures

CIRCUIT BOARD FOR TOP

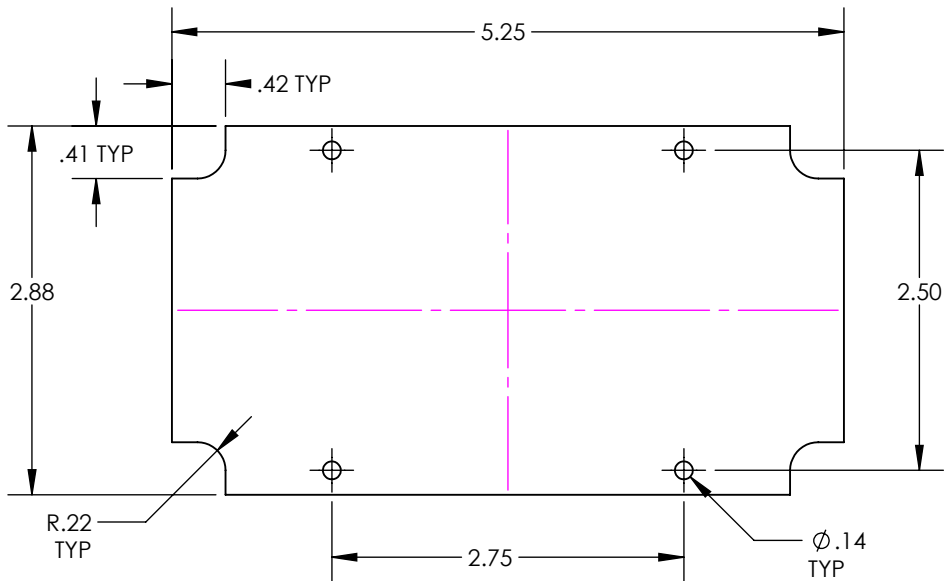

CIRCUIT BOARD FOR BOTTOM

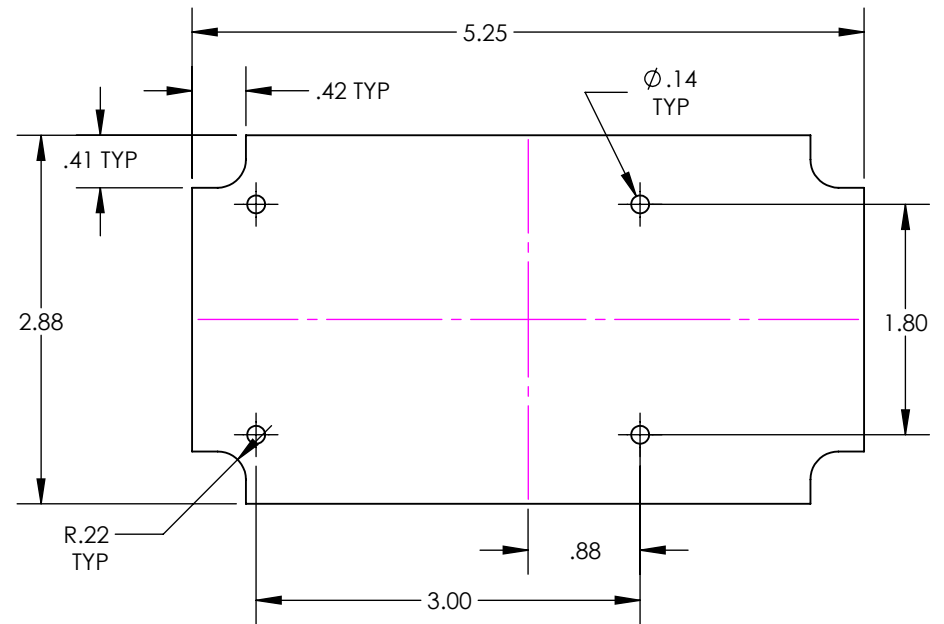

SMALL CIRCUIT BOARD FOR BOTTOM

