

SERPAC 153AC (exploded isometric)

Electronic Enclosures

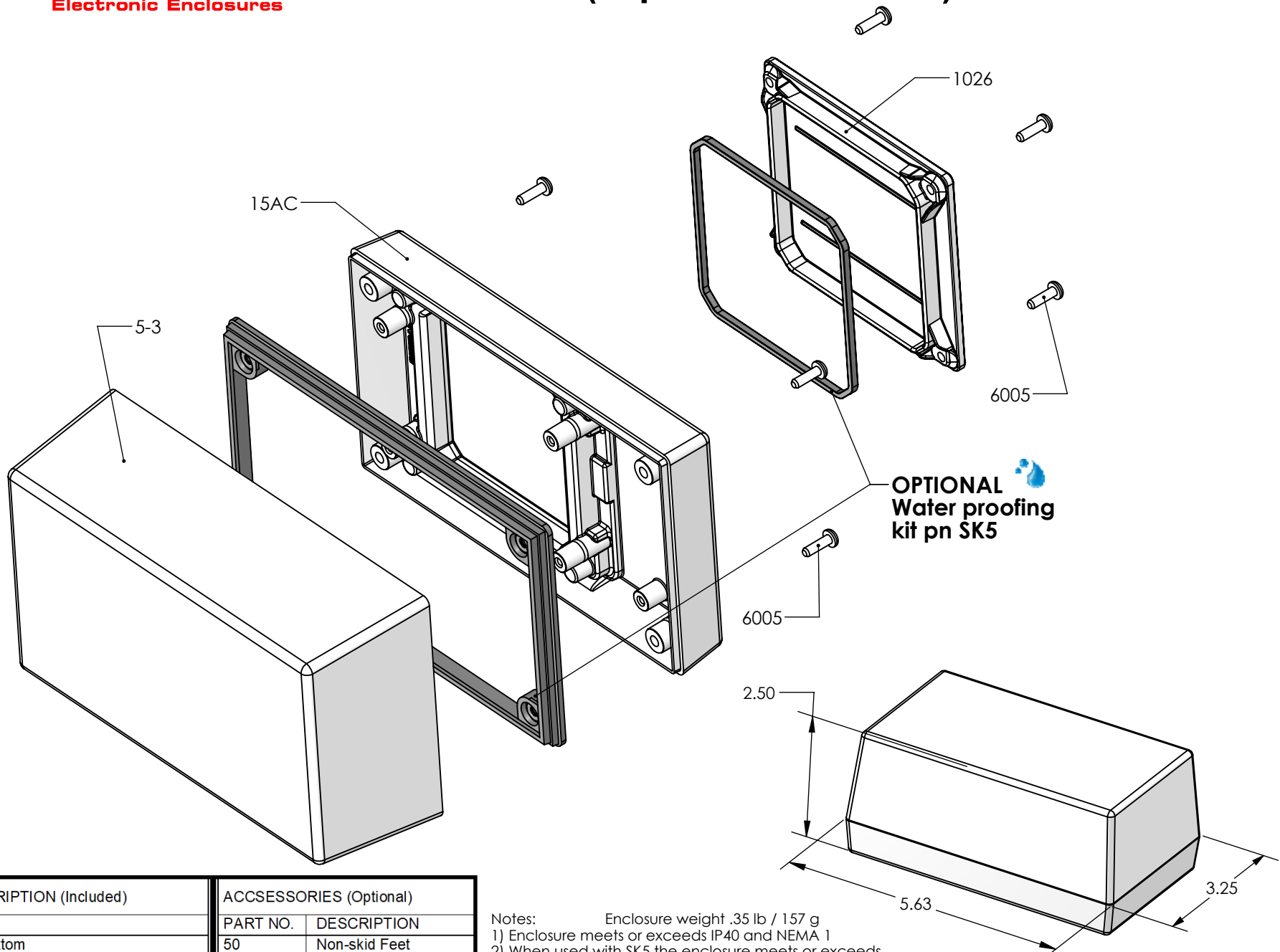

OPTIONAL
Water proofing
kit pn SK5

PART NO.	DESCRIPTION (Included)	ACCESSORIES (Optional)	
5-3	Top	PART NO.	DESCRIPTION
15AC	AC Bottom	50	Non-skid Feet
1026	Access Door	SK5	Seal Kit for 15X
6005	#4X3/8" Self-Tapping Screw (8)		

- Notes: Enclosure weight .35 lb / 157 g
- 1) Enclosure meets or exceeds IP40 and NEMA 1
 - 2) When used with SK5 the enclosure meets or exceeds IP 67 and NEMA 4X, 12 and 13 MIL-STD-810G 506.5 (.02 lb / 11g)
 - 3) Circuit Board drawings see sheet 3.
 - 4) All components are RoHS Compliant.

SERPAC 153AC

Electronic Enclosures

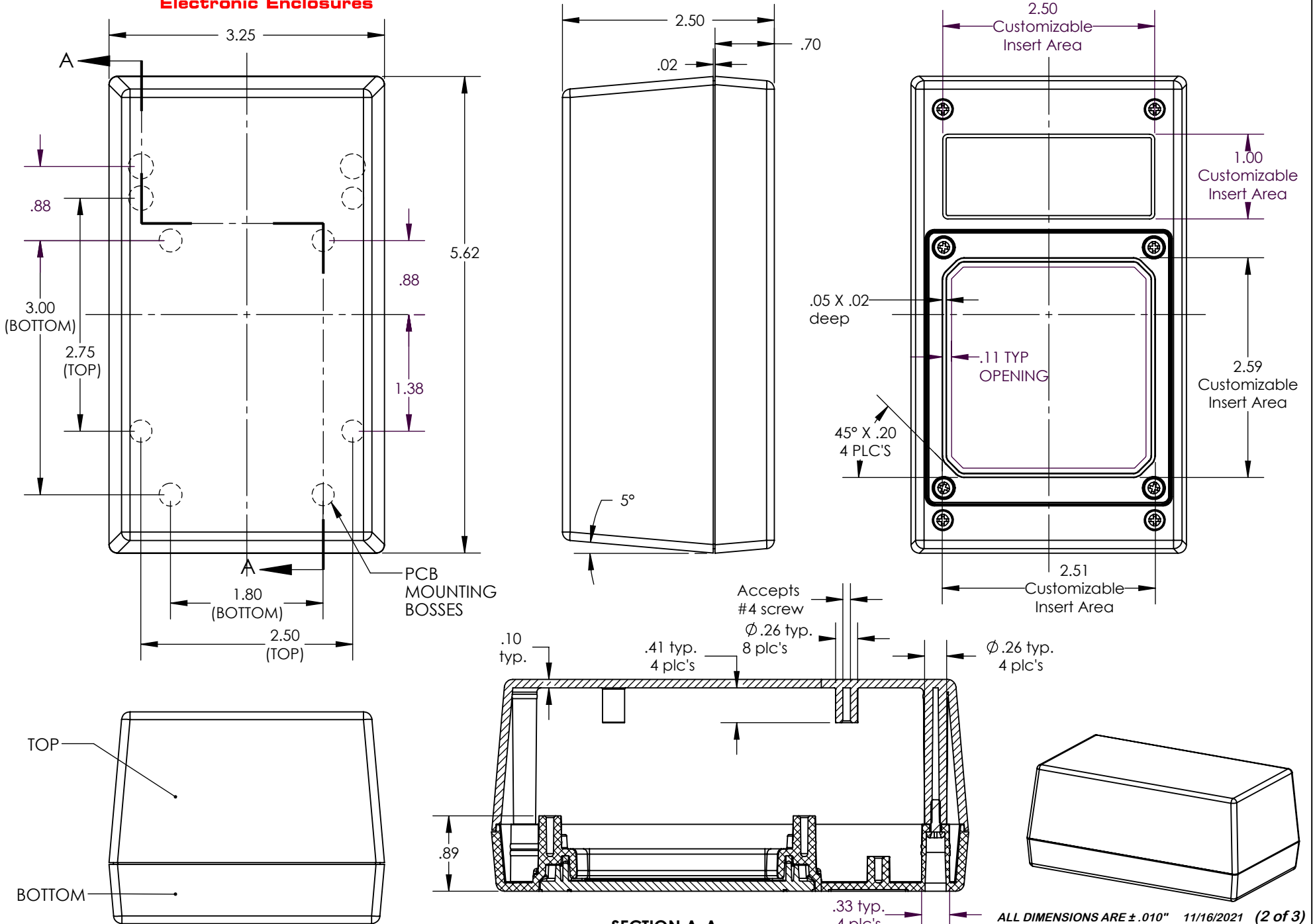

SECTION A-A

ALL DIMENSIONS ARE ±.010" 11/16/2021 (2 of 3)
 2009 Wright Ave. La Verne, CA 91750

Ph. (626) 331-0517 Fx. (626) 331-8584 www.serpac.com

SERPAC PCB for 15X compartment enclosures

Electronic Enclosures

CIRCUIT BOARD FOR TOP

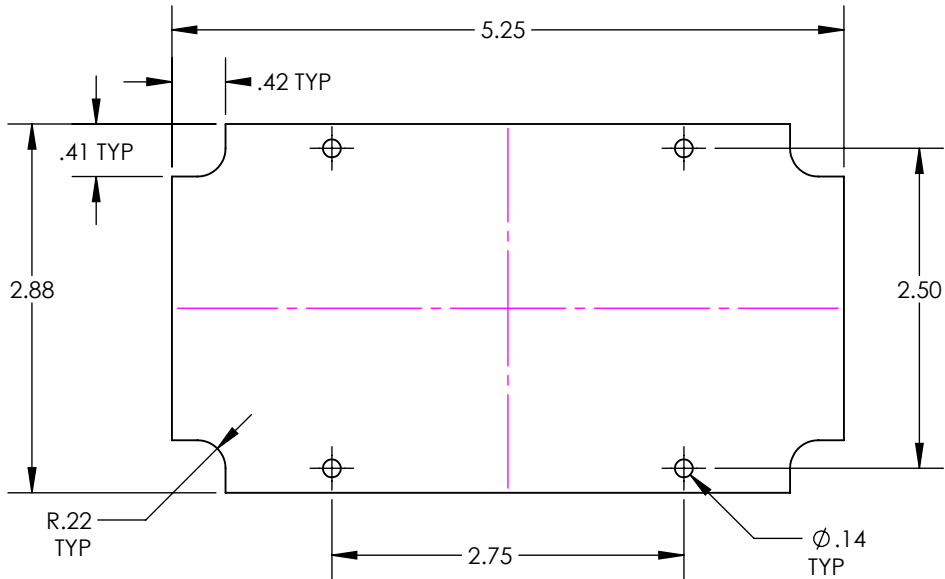

CIRCUIT BOARD FOR BOTTOM

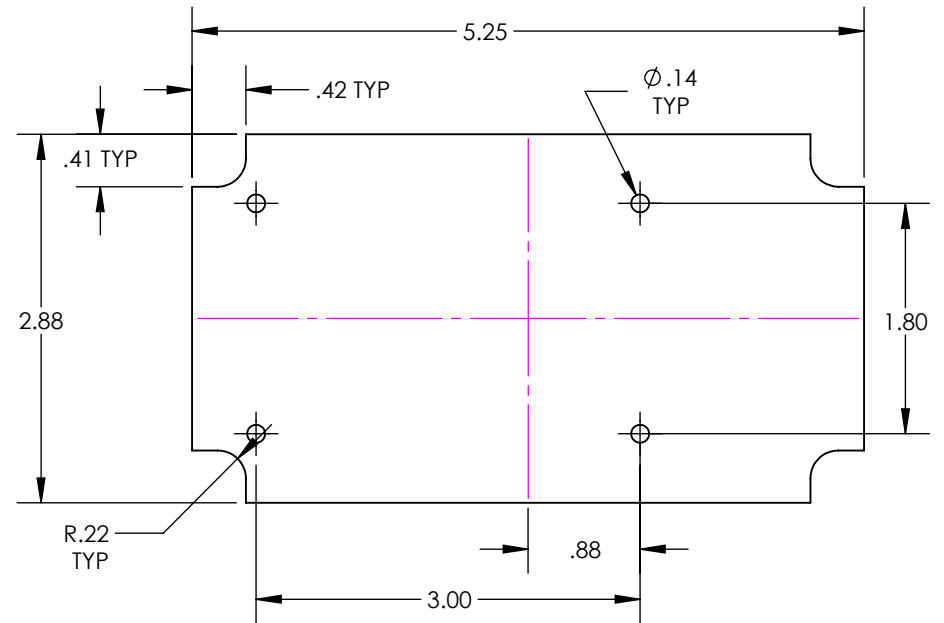

SMALL CIRCUIT BOARD FOR BOTTOM

