



## 3.3V CMOS Static RAM 1 Meg (64K x 16-Bit)

IDT71V016SA

### Features

- ◆ 64K x 16 advanced high-speed CMOS Static RAM
- ◆ Equal access and cycle times
  - Commercial: 10/12/15/20ns
  - Industrial: 10/12/15/20ns
- ◆ One Chip Select plus one Output Enable pin
- ◆ Bidirectional data inputs and outputs directly LVTTTL-compatible
- ◆ Low power consumption via chip deselect
- ◆ Upper and Lower Byte Enable Pins
- ◆ Single 3.3V power supply
- ◆ Available in 44-pin Plastic SOJ, 44-pin TSOP, and 48-Ball Plastic FBGA packages

### Description

The IDT71V016 is a 1,048,576-bit high-speed Static RAM organized as 64K x 16. It is fabricated using high-performance, high-reliability CMOS technology. This state-of-the-art technology, combined with innovative circuit design techniques, provides a cost-effective solution for high-speed memory needs.

The IDT71V016 has an output enable pin which operates as fast as 5ns, with address access times as fast as 10ns. All bidirectional inputs and outputs of the IDT71V016 are LVTTTL compatible and operation is from a single 3.3V supply. Fully static asynchronous circuitry is used, requiring no clocks or refresh for operation.

The IDT71V016 is packaged in a JEDEC standard 44-pin Plastic SOJ, a 44-pin TSOP Type II, and a 48-ball plastic 7 x 7 mm FBGA.

### Functional Block Diagram

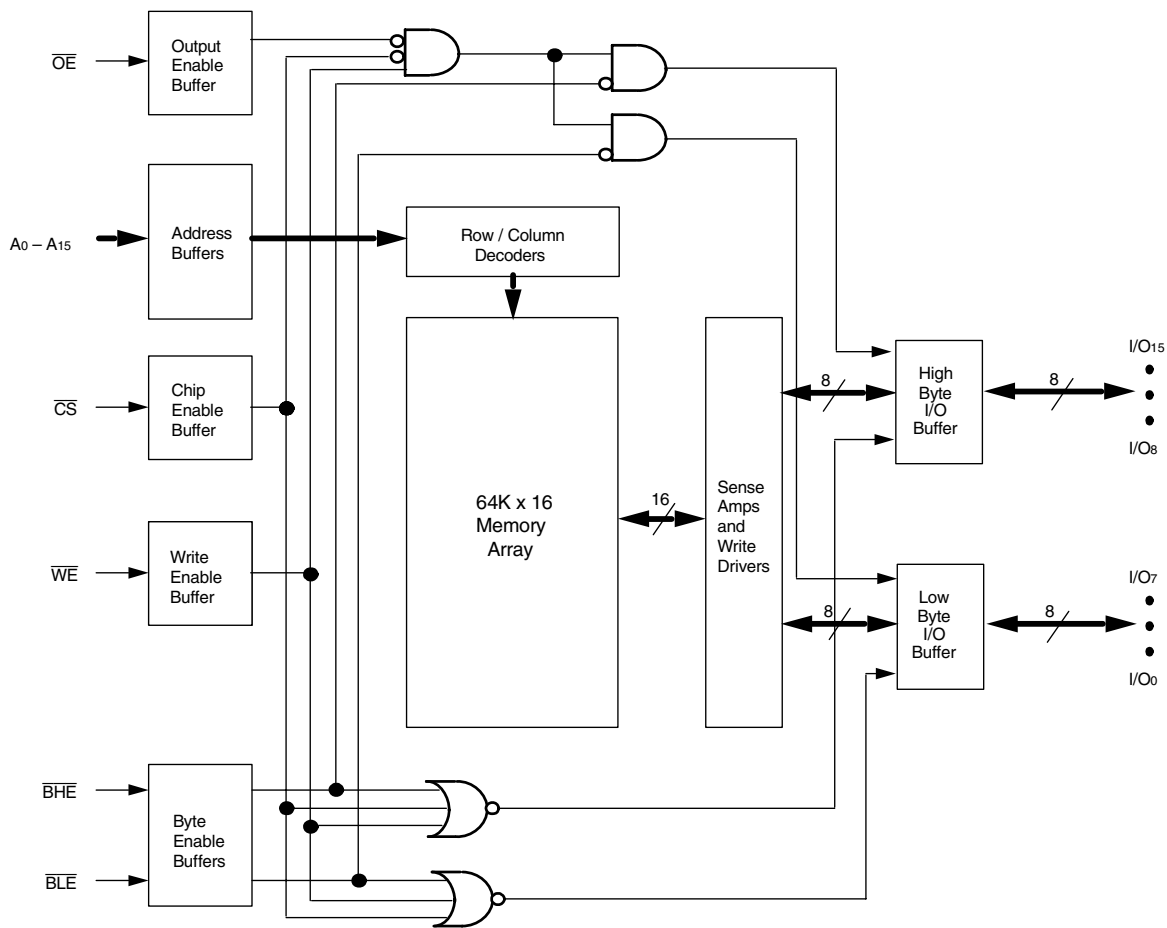

3834 drw 01

**AUGUST 2013**

## Pin Configurations

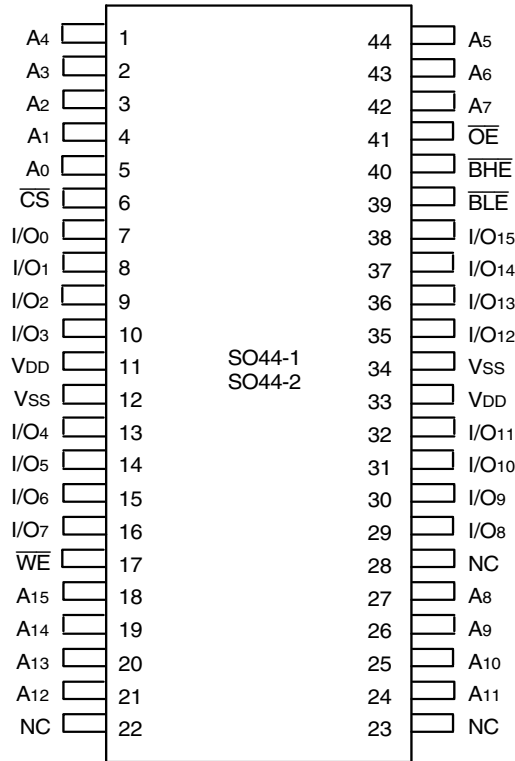

SOJ/T SOP  
Top View

3834 drw 02

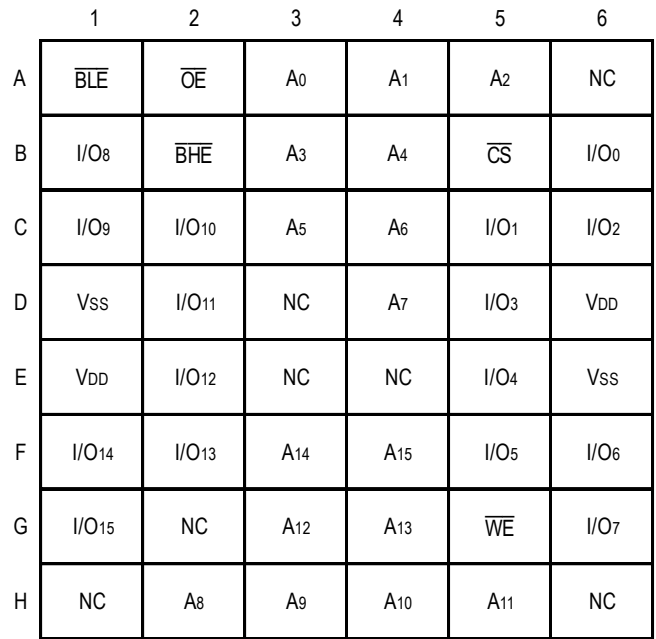

FBGA (BF48-1)  
Top View

3834 tbl 02a

## Pin Description

A0 – A15	Address Inputs	Input
$\overline{CS}$	Chip Select	Input
$\overline{WE}$	Write Enable	Input
$\overline{OE}$	Output Enable	Input
$\overline{BHE}$	High Byte Enable	Input
$\overline{BLE}$	Low Byte Enable	Input
I/O0 – I/O15	Data Input/Output	I/O
VDD	3.3V Power	Power
VSS	Ground	Gnd

3834 tbl 01

## Truth Table<sup>(1)</sup>

$\overline{CS}$	$\overline{OE}$	$\overline{WE}$	$\overline{BLE}$	$\overline{BHE}$	I/O0-I/O7	I/O8-I/O15	Function
H	X	X	X	X	High-Z	High-Z	Deselected – Standby
L	L	H	L	H	DATA <sub>OUT</sub>	High-Z	Low Byte Read
L	L	H	H	L	High-Z	DATA <sub>OUT</sub>	High Byte Read
L	L	H	L	L	DATA <sub>OUT</sub>	DATA <sub>OUT</sub>	Word Read
L	X	L	L	L	DATA <sub>IN</sub>	DATA <sub>IN</sub>	Word Write
L	X	L	L	H	DATA <sub>IN</sub>	High-Z	Low Byte Write
L	X	L	H	L	High-Z	DATA <sub>IN</sub>	High Byte Write
L	H	H	X	X	High-Z	High-Z	Outputs Disabled
L	X	X	H	H	High-Z	High-Z	Outputs Disabled

3834 tbl 02

**NOTE:**

1. H = V<sub>H</sub>, L = V<sub>L</sub>, X = Don't care.

## Absolute Maximum Ratings<sup>(1)</sup>

Symbol	Rating	Value	Unit
V <sub>DD</sub>	Supply Voltage Relative to V <sub>SS</sub>	-0.5 to +4.6	V
V <sub>IN</sub> , V <sub>OUT</sub>	Terminal Voltage Relative to V <sub>SS</sub>	-0.5 to V <sub>DD</sub> +0.5	V
T <sub>BIAS</sub>	Temperature Under Bias	-55 to +125	°C
T <sub>STG</sub>	Storage Temperature	-55 to +125	°C
P <sub>T</sub>	Power Dissipation	1.25	W
I <sub>OUT</sub>	DC Output Current	50	mA

**NOTE:**

- Stresses greater than those listed under ABSOLUTE MAXIMUM RATINGS may cause permanent damage to the device. This is a stress rating only and functional operation of the device at these or any other conditions above those indicated in the operational sections of this specification is not implied. Exposure to absolute maximum rating conditions for extended periods may affect reliability.

3834 tbl 03

## Capacitance

(T<sub>A</sub> = +25°C, f = 1.0MHz, SOJ package)

Symbol	Parameter <sup>(1)</sup>	Conditions	Max.	Unit
C <sub>IN</sub>	Input Capacitance	V <sub>IN</sub> = 3dV	6	pF
C <sub>I/O</sub>	I/O Capacitance	V <sub>OUT</sub> = 3dV	7	pF

**NOTE:**

- This parameter is guaranteed by device characterization, but not production tested.

3834 tbl 06

## Recommended Operating Temperature and Supply Voltage

Grade	Temperature	V <sub>SS</sub>	V <sub>DD</sub>
Commercial	0°C to +70°C	0V	See Below
Industrial	-40°C to +85°C	0V	See Below

3834 tbl 04

## Recommended DC Operating Conditions

Symbol	Parameter	Min.	Typ.	Max.	Unit
V <sub>DD</sub> <sup>(1)</sup>	Supply Voltage	3.15	3.3	3.6	V
V <sub>DD</sub> <sup>(2)</sup>	Supply Voltage	3.0	3.3	3.6	V
V <sub>SS</sub>	Ground	0	0	0	V
V <sub>IH</sub>	Input High Voltage	2.0	—	V <sub>DD</sub> +0.3 <sup>(3)</sup>	V
V <sub>IL</sub>	Input Low Voltage	-0.3 <sup>(4)</sup>	—	0.8	V

3834 tbl 05

**NOTES:**

- For 71V016SA10 only.
- For all speed grades except 71V016SA10.
- V<sub>IH</sub> (max.) = V<sub>DD</sub>+2V for pulse width less than 5ns, once per cycle.
- V<sub>IL</sub> (min.) = -2V for pulse width less than 5ns, once per cycle.

## DC Electrical Characteristics

(V<sub>DD</sub> = Min. to Max., Commercial and Industrial Temperature Ranges)

Symbol	Parameter	Test Condition	IDT71V016SA		Unit
			Min.	Max.	
I <sub>LI</sub>	Input Leakage Current	V <sub>DD</sub> = Max., V <sub>IN</sub> = V <sub>SS</sub> to V <sub>DD</sub>	—	5	μA
I <sub>LO</sub>	Output Leakage Current	V <sub>DD</sub> = Max., $\overline{CS}$ = V <sub>IH</sub> , V <sub>OUT</sub> = V <sub>SS</sub> to V <sub>DD</sub>	—	5	μA
V <sub>OL</sub>	Output Low Voltage	I <sub>OL</sub> = 8mA, V <sub>DD</sub> = Min.	—	0.4	V
V <sub>OH</sub>	Output High Voltage	I <sub>OH</sub> = -4mA, V <sub>DD</sub> = Min.	2.4	—	V

3834 tbl 07

## DC Electrical Characteristics<sup>(1,2)</sup>

(V<sub>DD</sub> = Min. to Max., V<sub>LC</sub> = 0.2V, V<sub>HC</sub> = V<sub>DD</sub> - 0.2V)

Symbol	Parameter		71V016SA10		71V016SA12		71V016SA15		71V016SA20		Unit
			Com'l	Ind'l	Com'l	Ind'l	Com'l	Ind'l	Com'l	Ind'l	
I <sub>CC</sub>	Dynamic Operating Current $\overline{CS} \leq V_{LC}$ , Outputs Open, V <sub>DD</sub> = Max., f = f <sub>MAX</sub> <sup>(3)</sup>	Max.	160	170	150	160	130	130	120	120	mA
		Typ. <sup>(4)</sup>	65	--	60	--	55	--	50	--	
I <sub>SB</sub>	Dynamic Standby Power Supply Current $\overline{CS} \geq V_{HC}$ , Outputs Open, V <sub>DD</sub> = Max., f = f <sub>MAX</sub> <sup>(3)</sup>		45	50	40	45	35	35	30	30	mA
I <sub>SB1</sub>	Full Standby Power Supply Current (static) $\overline{CS} \geq V_{HC}$ , Outputs Open, V <sub>DD</sub> = Max., f = 0 <sup>(3)</sup>		10	10	10	10	10	10	10	10	mA

**NOTES:**

- All values are maximum guaranteed values.
- All inputs switch between 0.2V (Low) and V<sub>DD</sub> - 0.2V (High).
- f<sub>MAX</sub> = 1/trc (all address inputs are cycling at f<sub>MAX</sub>); f = 0 means no address input lines are changing.
- Typical values are based on characterization data for H step only measured at 3.3V, 25°C and with equal read and write cycles.

3834 tbl 08

## AC Test Conditions

Input Pulse Levels	GND to 3.0V
Input Rise/Fall Times	1.5ns
Input Timing Reference Levels	1.5V
Output Reference Levels	1.5V
AC Test Load	See Figure 1, 2 and 3

3834 tbl 09

## AC Test Loads

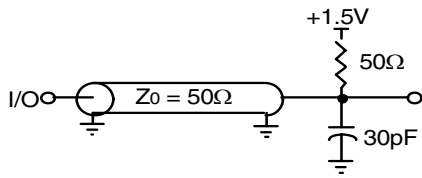

3834 drw 03

Figure 1. AC Test Load

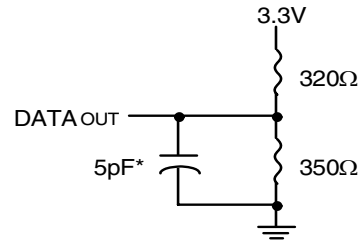

3834 drw 04

\*Including jig and scope capacitance.

Figure 2. AC Test Load  
(for tCLZ, tOLZ, tCHZ, tOHZ, tOW, and tWHZ)

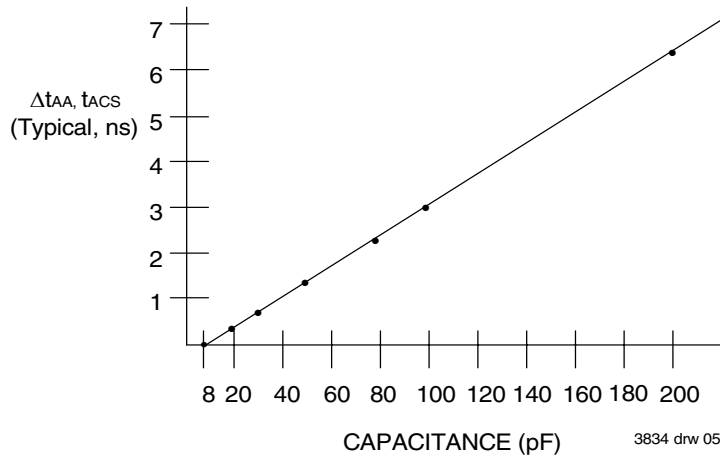

3834 drw 05

Figure 3. Output Capacitive Derating

### AC Electrical Characteristics (V<sub>DD</sub> = Min. to Max., Commercial and Industrial Temperature Ranges)

Symbol	Parameter	71V016SA10		71V016SA12		71V016SA15		71V016SA20		Unit
		Min.	Max.	Min.	Max.	Min.	Max.	Min.	Max.	
<b>READ CYCLE</b>										
t <sub>RC</sub>	Read Cycle Time	10	—	12	—	15	—	20	—	ns
t <sub>AA</sub>	Address Access Time	—	10	—	12	—	15	—	20	ns
t <sub>ACS</sub>	Chip Select Access Time	—	10	—	12	—	15	—	20	ns
t <sub>CLZ</sub> <sup>(1)</sup>	Chip Select Low to Output in Low-Z	4	—	4	—	5	—	5	—	ns
t <sub>CHZ</sub> <sup>(1)</sup>	Chip Select High to Output in High-Z	—	5	—	6	—	6	—	8	ns
t <sub>OE</sub>	Output Enable Low to Output Valid	—	5	—	6	—	7	—	8	ns
t <sub>OLZ</sub> <sup>(1)</sup>	Output Enable Low to Output in Low-Z	0	—	0	—	0	—	0	—	ns
t <sub>OHZ</sub> <sup>(1)</sup>	Output Enable High to Output in High-Z	—	5	—	6	—	6	—	8	ns
t <sub>OH</sub>	Output Hold from Address Change	4	—	4	—	4	—	4	—	ns
t <sub>BE</sub>	Byte Enable Low to Output Valid	—	5	—	6	—	7	—	8	ns
t <sub>BLZ</sub> <sup>(1)</sup>	Byte Enable Low to Output in Low-Z	0	—	0	—	0	—	0	—	ns
t <sub>BHZ</sub> <sup>(1)</sup>	Byte Enable High to Output in High-Z	—	5	—	6	—	6	—	8	ns
<b>WRITE CYCLE</b>										
t <sub>WC</sub>	Write Cycle Time	10	—	12	—	15	—	20	—	ns
t <sub>AW</sub>	Address Valid to End of Write	7	—	8	—	10	—	12	—	ns
t <sub>CW</sub>	Chip Select Low to End of Write	7	—	8	—	10	—	12	—	ns
t <sub>BW</sub>	Byte Enable Low to End of Write	7	—	8	—	10	—	12	—	ns
t <sub>AS</sub>	Address Set-up Time	0	—	0	—	0	—	0	—	ns
t <sub>WR</sub>	Address Hold from End of Write	0	—	0	—	0	—	0	—	ns
t <sub>WP</sub>	Write Pulse Width	7	—	8	—	10	—	12	—	ns
t <sub>DW</sub>	Data Valid to End of Write	5	—	6	—	7	—	9	—	ns
t <sub>DH</sub>	Data Hold Time	0	—	0	—	0	—	0	—	ns
t <sub>OW</sub> <sup>(1)</sup>	Write Enable High to Output in Low-Z	3	—	3	—	3	—	3	—	ns
t <sub>WHZ</sub> <sup>(1)</sup>	Write Enable Low to Output in High-Z	—	5	—	6	—	6	—	8	ns

**NOTE:**

3834 tbl 10

1. This parameter is guaranteed with the AC Load (Figure 2) by device characterization, but is not production tested.

### Timing Waveform of Read Cycle No. 1 (1,2,3)

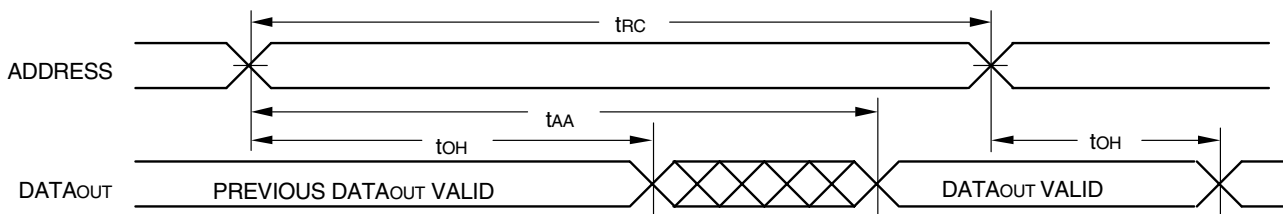

**NOTES:**

3834 drw 06

1.  $\overline{WE}$  is HIGH for Read Cycle.
2. Device is continuously selected,  $\overline{CS}$  is LOW.
3.  $\overline{OE}$ ,  $\overline{BHE}$ , and  $\overline{BLE}$  are LOW.

## Timing Waveform of Read Cycle No. 2<sup>(1)</sup>

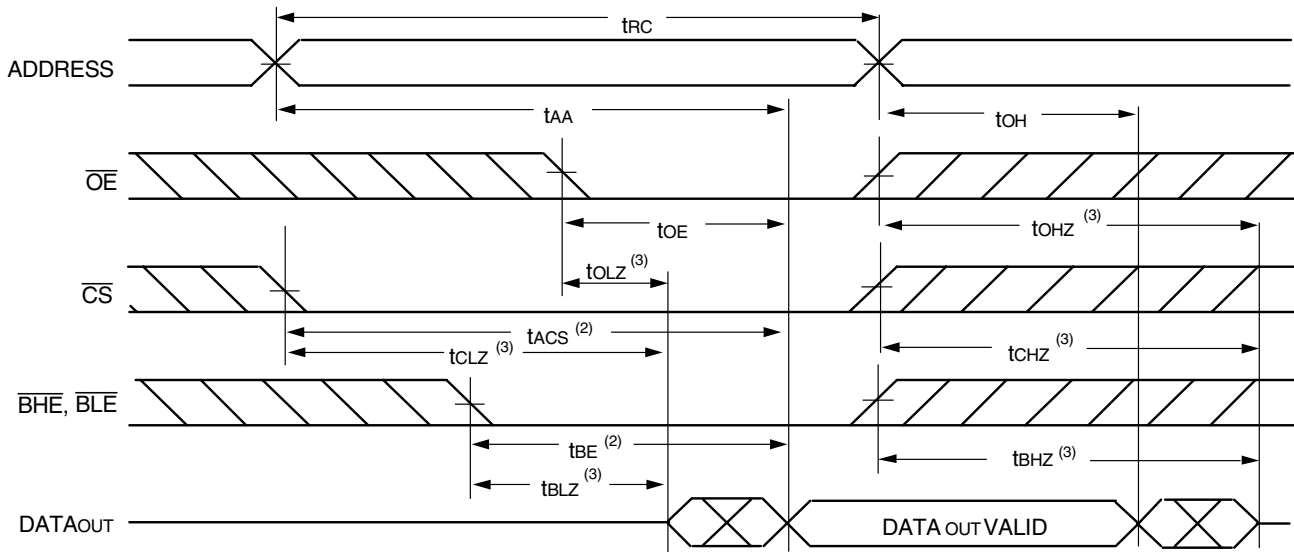

3834 drw 07

### NOTES:

1.  $\overline{WE}$  is HIGH for Read Cycle.
2. Address must be valid prior to or coincident with the later of  $\overline{CS}$ ,  $\overline{BHE}$ , or  $\overline{BLE}$  transition LOW; otherwise  $t_{AA}$  is the limiting parameter.
3. Transition is measured  $\pm 200\text{mV}$  from steady state.

## Timing Waveform of Write Cycle No. 1 ( $\overline{WE}$ Controlled Timing)<sup>(1,2,4)</sup>

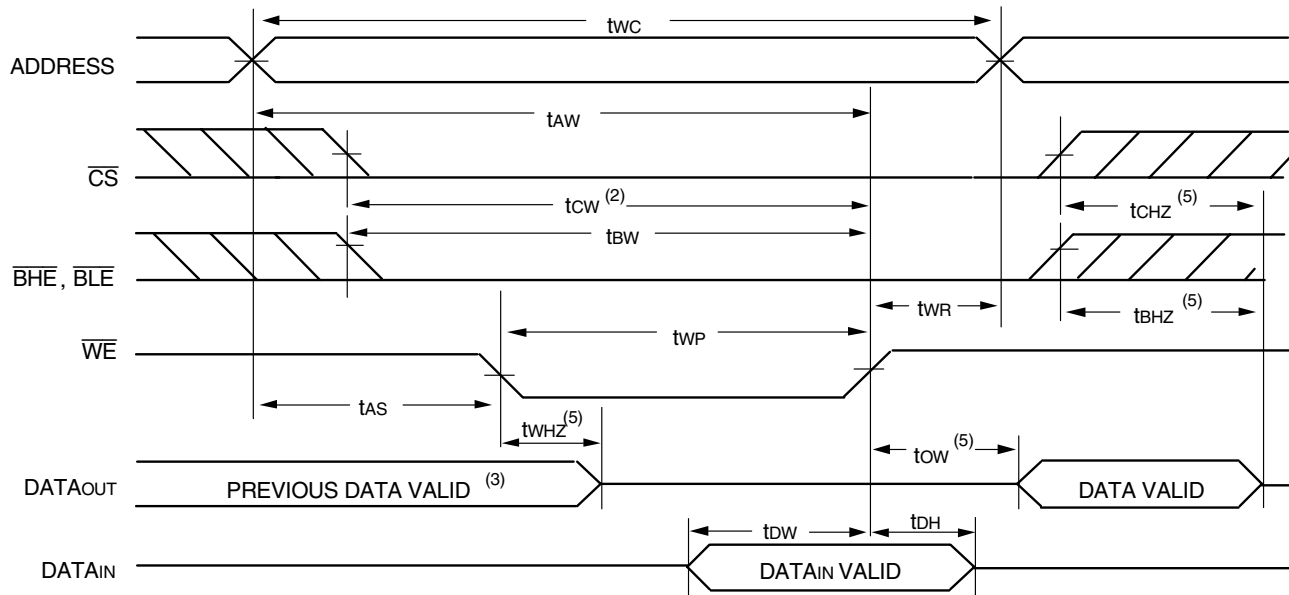

3834 drw 08

### NOTES:

1. A write occurs during the overlap of a LOW  $\overline{CS}$ , LOW  $\overline{BHE}$  or  $\overline{BLE}$ , and a LOW  $\overline{WE}$ .
2.  $\overline{OE}$  is continuously HIGH. If during a  $\overline{WE}$  controlled write cycle  $\overline{OE}$  is LOW,  $t_{WP}$  must be greater than or equal to  $t_{WHZ} + t_{DW}$  to allow the I/O drivers to turn off and data to be placed on the bus for the required  $t_{DW}$ . If  $\overline{OE}$  is HIGH during a  $\overline{WE}$  controlled write cycle, this requirement does not apply and the minimum write pulse is as short as the specified  $t_{WP}$ .
3. During this period, I/O pins are in the output state, and input signals must not be applied.
4. If the  $\overline{CS}$  LOW or  $\overline{BHE}$  and  $\overline{BLE}$  LOW transition occurs simultaneously with or after the  $\overline{WE}$  LOW transition, the outputs remain in a high-impedance state.
5. Transition is measured  $\pm 200\text{mV}$  from steady state.

### Timing Waveform of Write Cycle No. 2 ( $\overline{\text{CS}}$ Controlled Timing)<sup>(1,4)</sup>

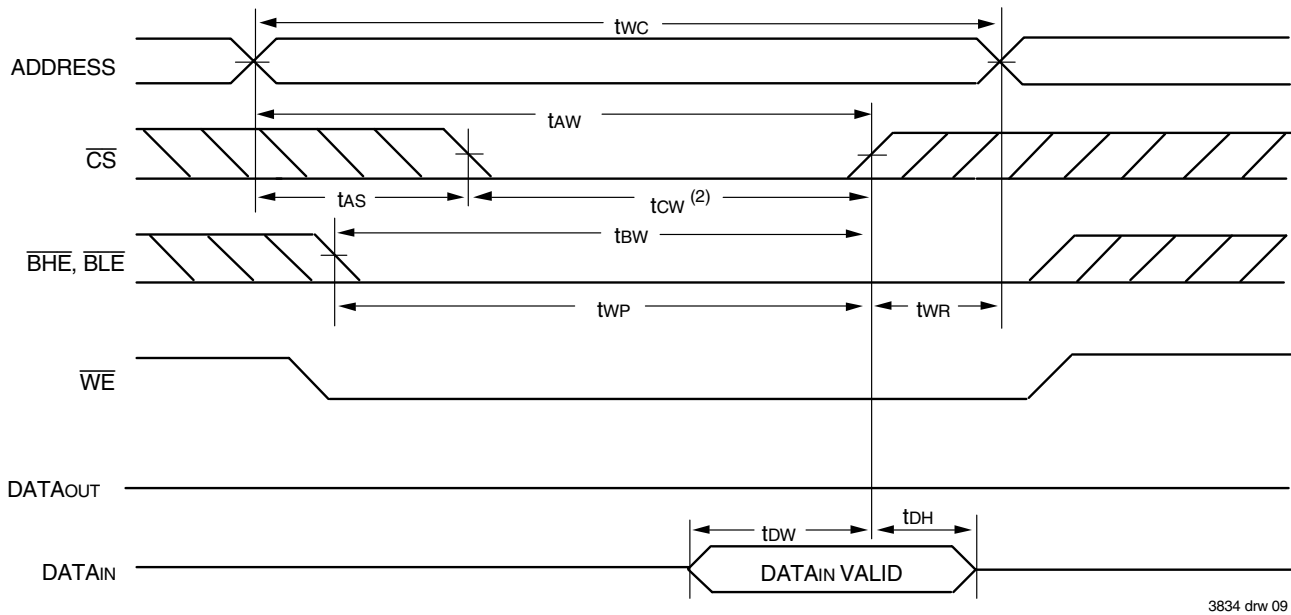

### Timing Waveform of Write Cycle No. 3 ( $\overline{\text{BHE}}$ , $\overline{\text{BLE}}$ Controlled Timing)<sup>(1,4)</sup>

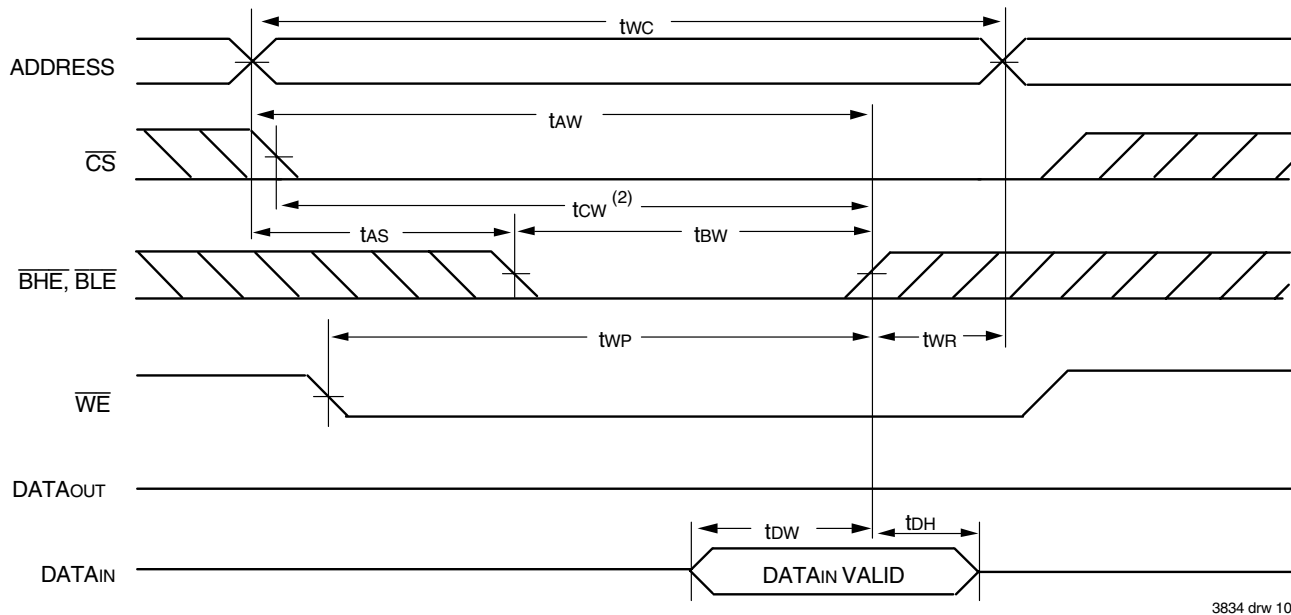

**NOTES:**

1. A write occurs during the overlap of a LOW  $\overline{\text{CS}}$ , LOW  $\overline{\text{BHE}}$  or  $\overline{\text{BLE}}$ , and a LOW  $\overline{\text{WE}}$ .
2.  $\overline{\text{OE}}$  is continuously HIGH. If during a  $\overline{\text{WE}}$  controlled write cycle  $\overline{\text{OE}}$  is LOW,  $t_{WP}$  must be greater than or equal to  $t_{WHZ} + t_{DW}$  to allow the I/O drivers to turn off and data to be placed on the bus for the required  $t_{DW}$ . If  $\overline{\text{OE}}$  is HIGH during a  $\overline{\text{WE}}$  controlled write cycle, this requirement does not apply and the minimum write pulse is as short as the specified  $t_{WR}$ .
3. During this period, I/O pins are in the output state, and input signals must not be applied.
4. If the  $\overline{\text{CS}}$  LOW or  $\overline{\text{BHE}}$  and  $\overline{\text{BLE}}$  LOW transition occurs simultaneously with or after the  $\overline{\text{WE}}$  LOW transition, the outputs remain in a high-impedance state.
5. Transition is measured  $\pm 200\text{mV}$  from steady state.

## Ordering Information

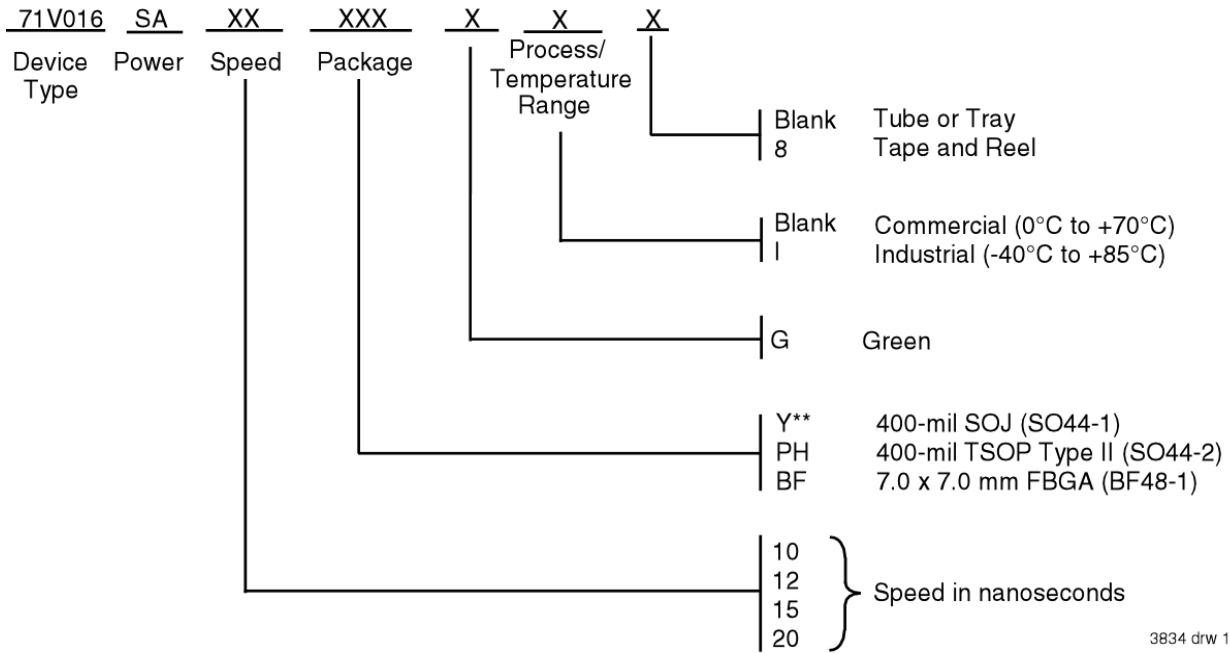

3834 drw 11

\*\* This package not available in 10ns Industrial temperature range.



## Datasheet Document History

01/07/00		Updated to new format
	Pg. 1, 3, 5, 8	Added Industrial Temperature range offerings
	Pg. 2	Numbered I/Os and address pins on FBGA Top View
	Pg. 6	Revised footnotes on Write Cycle No. 1 diagram
	Pg. 7	Revised footnotes on Write Cycle No. 2 and No. 3 diagrams
	Pg. 9	Added Datasheet Document History
08/30/00	Pg. 3	Tighten ICC and ISB.
	Pg. 5	Tighten tCLZ, tCHZ, tOHZ, tBHZ and tWHZ
08/22/01	Pg. 8	Removed footnote "available in 15ns and 20ns only"
06/20/02	Pg. 8	Added tape and reel field to ordering information
01/30/04	Pg. 8	Added "Restricted hazardous substance device" to ordering information.
09/27/06	Pg. 8	Corrected ordering information, changed position of I and G.
02/14/07	Pg. 8	Added H step generation to data sheet ordering information.
06/26/07	Pg. 3	Changed typical parameters for ICC, DC electrical characteristics table.
10/13/08	Pg. 8	Removed "IDT" from orderable part number
10/11/11	Pg. 1,8	Updated datasheet with removal of Obsolete HSA part number.
08/13/13	Pg. 1,3,5,8	Added 10ns for Industrial Temperature range offerings.



**CORPORATE HEADQUARTERS**  
6024 Silver Creek Valley Road  
San Jose, CA 95138

**for SALES:**  
800-345-7015 or  
408-284-8200  
fax: 408-284-2775  
[www.idt.com](http://www.idt.com)

**for Tech Support:**  
[ipchelp@idt.com](mailto:ipchelp@idt.com)  
800-345-7015

The IDT logo is a registered trademark of Integrated Device Technology, Inc.