

PART NAME: KNOB SCALE: 1:1 DATE: 1/6/92 DR. BY HD

THIS DRAWING IS THE PROPERTY OF DAVIES MOLDING COMPANY, IS SUBMITTED SOLELY AS A DESIGN OR ENGINEERING PROJECT. WE ACCEPT NO RESPONSIBILITY WHATSOEVER FOR THE PRACTICAL APPLICATION OF THE PIECES MADE TO THIS DESIGN.



DESIGNERS & MANUFACTURERS OF KNOBS, HANDLES, CASES & CUSTOM PLASTIC COMPONENTS

P/N 4202	
M NO. # 73-FRAME	
CAVITY	4202
CORE	4200
CAV. PLUG	4202
K.O.SLEEVE	M-4200
SLEEVE	4200
ⓐ OUTER PIN	4200
PIN	4200-B
INSERT	11334

CAD/REDRAWN : 2/25/93 : HD

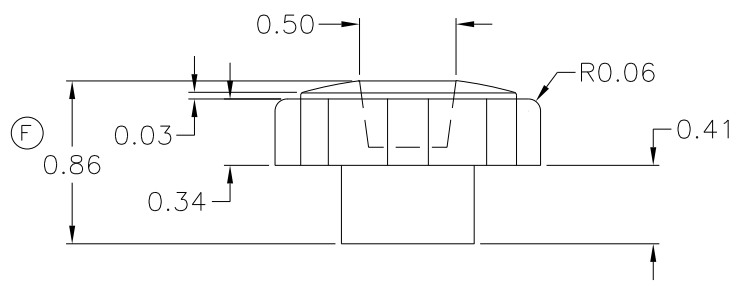
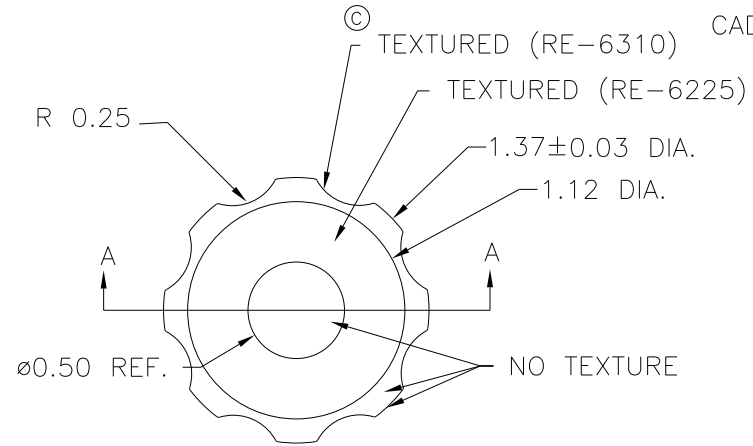

SECTION "A-A"

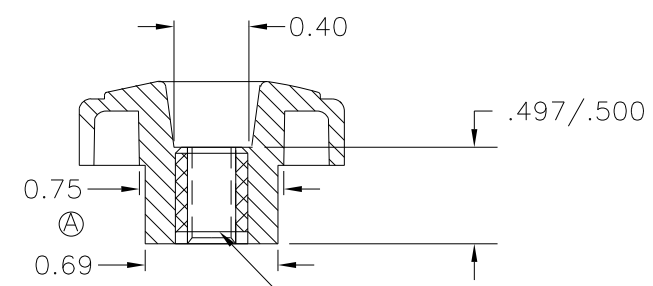

NOTE: ADD LEG & PILLAR SHIM 0.005 ONLY FOR FRAME 73-2.

1/4-20 UNC-2B THD'D. FM. 11334; H.H.BRASS

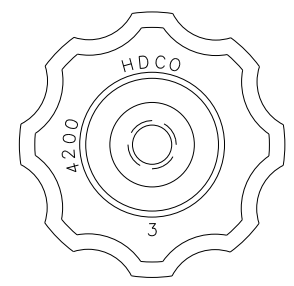

(C) (A)

(B) MATERIAL: 20% TALC-FILLED POLYPROPYLENE (BC9) (E)
COLOR: BLACK

TOLERANCES: UNLESS OTHERWISE SPECIFIED	DO NOT SCALE DRAWING
DECIMALS: X.XXX ± .005 X.XX ± .015	MM: X.XX ± 0.15MM X.X ± 0.4MM
FRACTIONS ± 1/64	ANG. ± 1°

F	WAS 0.84	JAM	11/17/14
E	ADDED MAT. CODE	DS	1/29/07
D	ADD OUTER PIN	LS	9/2/03
C	UPDATED TEXTURE NOTES, REMOVED REF. DIMENSIONS	JAM	12/18/01
B	Was Polypropylene	MH	2/16/99
A	ADD .75 DIM.	RP	11/27/96

CHANGES