

MAX14883E Evaluation Kit

Evaluates: MAX14883E

General Description

The MAX14883E evaluation kit (EV kit) is a fully assembled and tested PCB that demonstrates the functionality of the MAX14883E fault-protected controller area network (CAN) transceiver. The EV kit operates from a 5V supply.

Features

- Operates from a Single 5V Supply
- Terminal Block Connectors for Easy CAN System Evaluation
- Fully Assembled and Tested

Quick Start

Required Equipment

- MAX14883E EV Kit
- 5V, 500mA DC power supply
- Signal/function generator
- Oscilloscope

Startup Procedure

The MAX14883E EV kit is fully assembled and tested. Follow the steps below to verify board operation.

- 1) Set the power supply to 5V and connect the power supply to the V_{DD} test point (TP9). Connect the ground terminal of the power supply to the GND test point (TP8).
- 2) Ensure that all jumpers are in their default positions (see [Table 1](#)).
- 3) Turn on the power supply.
- 4) Set the signal/function generator to output a 500kHz 0V-to-5V square wave.
- 5) Connect the signal/function generator to the TXD test point (TP1).
- 6) Connect two oscilloscope probes to TXD (TP1) and RXD (TP3), respectively, to verify that the signal on RXD is the same as on TXD.
- 7) To view the CANH and CANL signals, connect the scope probes to the CANH test point (TP15) and the CANL test point (TP14).

[Ordering Information](#) appears at end of data sheet.

Detailed Description of Hardware

The MAX14883E EV kit is a fully assembled and tested circuit board for evaluating the MAX14883E fault-protected CAN transceiver (U3). The EV kit has been designed to allow for evaluating the MAX14883E alone or in a CAN system.

Powering the Board

Connect a 5V supply to the external supply to the V_{DD} test point (TP9) to power the MAX14883E transceiver. The ground terminal of the 5V supply must be connected.

On-Board Termination

A properly terminated CAN bus is terminated at each end with the characteristic impedance of the cable. For cat5 or cat6 cables, this is typically 120 Ω on each end for a

60 Ω load on the CAN driver. The MAX14883E EV kit features a selectable split 60 Ω -60 Ω -47nF termination circuit between the CANH and CANL driver outputs. If the board is being evaluated in a system and is connected at the end of the cable, close the J3 jumper and the J2 jumper to enable this termination. If the board is connected to a bus that is terminated elsewhere, open J3 and J2 to avoid loading the bus down further.

To evaluate performance with a non-split termination (resistive termination only between CANH and CANL), open the J2 jumper to disconnect the C3 capacitor from ground.

The termination resistors on the MAX14883E EV should be changed to 30 Ω -30 Ω -47nF (a 60 Ω load, total) to simulate a complete system load during evaluation.

Table 1. Jumper Table (J1-J7)

JUMPER	SHUNT POSITION	DESCRIPTION
J1	Open	V_L is not connected to V_{DD} . Apply an external voltage to V_L .
	Closed*	V_L is connected to V_{DD} .
J2	Open	Split termination capacitor is not connected.
	Closed*	Split termination capacitor is connected.
J3	Open	CANH and CANL are not connected through the on-board resistor termination network.
	Closed*	CANH and CANL are connected through the on-board resistor termination network.
J6	Open	External diode protection is not connected to CANH.
	Closed*	External diode protection is connected to CANH.
J7	Open	External diode protection is not connected to CANL.
	Closed*	External diode protection is connected to CANL.
J8	1-2	POL is connected to V_L .
	2-3*	POL is connected to GND.
J9	1-2	TXD is connected to V_L .
	2-3*	TXD is connected to GND.

*Default position.

MAX14883E EV Kit Bill of Materials

ITEM	REF_DES	DNI/DNP	QTY	MFG PART #	MANUFACTURER	VALUE	DESCRIPTION
1	C3	-	1	C0805C473J1RAC	KEMET	0.047UF	CAPACITOR; SMT; 0805; CERAMIC; 0.047uF;100V; 5%; X7R; -55degC to +125degC
2	C5, C6	-	2	C0603C104K5RAC; C1608X7R1H104K	KEMET;TDK	0.1UF	CAPACITOR; SMT (0603); CERAMIC CHIP; 0.1UF; 50V; TOL=10%; TG=-55 DEGC TO +125 DEGC; TC=X7R;
3	C7	-	1	C3216X5R1H106K; GRM31CR61H106KA12	TDK;MURATA	10UF	CAPACITOR; SMT (1206); CERAMIC CHIP; 10UF; 50V; TOL=10%; TG=-55 DEGC TO +85 DEGC; TC=X5R
4	D1, D2	-	2	SMAJ30A	LITTELFUSE	30V	DIODE; TVS; SMA (DO-214AC); VRM=30V; IF=8.3A
5	D3-D6	-	4	1N4001	ON SEMICONDUCTOR	1N4001G	DIODE; RECT; THROUGH HOLE-AXIAL LEAD (DO-41); PIV=50V; IF=1A
6	J1-J3, J6, J7	-	5	PBC02SAAN	SULLINS ELECTRONICS CORP.	PBC02SAAN	EVKIT PART-CONNECTOR; MALE; THROUGH HOLE; BREAKAWAY; STRAIGHT; 2PINS; -65 DEGC TO +125 DEGC;
7	J4	-	1	PBC05SAAN	SULLINS ELECTRONICS CORP.	PBC05SAAN	CONNECTOR; MALE; THROUGH HOLE; BREAKAWAY; STRAIGHT; 5PINS; -65 DEGC TO +125 DEGC
8	J5	-	1	OSTTC042162	ON-SHORE TECHNOLOGY INC	OSTTC042162	CONNECTOR; FEMALE; THROUGH HOLE; TERMINAL BLOCK ONE PIECE WIRE PROTECTOR; COLOR BLUE; RIGHT ANGLE; 4PINS
9	J8, J9	-	2	PCC03SAAN	SULLINS	PCC03SAAN	CONNECTOR; MALE; THROUGH HOLE; BREAKAWAY; STRAIGHT THROUGH; 3PINS; -65 DEGC TO +125 DEGC
10	R1, R2	-	2	CRCW060360R4FK	VISHAY DALE	60.4	RESISTOR; 0603; 60.4 OHM; 1%; 100PPM; 0.10W; THICK FILM
11	TP1-TP3, TP14, TP15	-	5	5014	KEystone	N/A	TEST POINT; PIN DIA=0.125IN; TOTAL LENGTH=0.445IN; BOARD HOLE=0.063IN; YELLOW; PHOSPHOR BRONZE WIRE SILVER PLATE FINISH;
12	TP7, TP8	-	2	5011	KEystone	N/A	TEST POINT; PIN DIA=0.125IN; TOTAL LENGTH=0.445IN; BOARD HOLE=0.063IN; BLACK; PHOSPHOR BRONZE WIRE SILVER PLATE FINISH;
13	TP9, TP10	-	2	5010	KEystone	N/A	TESTPOINT WITH 1.80MM HOLE DIA, RED, MULTIPURPOSE;
14	U3	-	1	MAX14883EASA+	MAXIM	MAX14883EASA+	IC; TXRX; CAN TRANSCEIVER WITH +/-60V FAULT PROTECTION AND SELECTABLE POLARITY; NSOIC8
15	PCB	-	1	MAX14883E	MAXIM	PCB	PCB:MAX14883E
TOTAL			32				

Ordering Information

PART	TYPE
MAX14883E EVKIT#	EV Kit

#Denotes RoHS compliant.

MAX14883E EV Kit Schematic

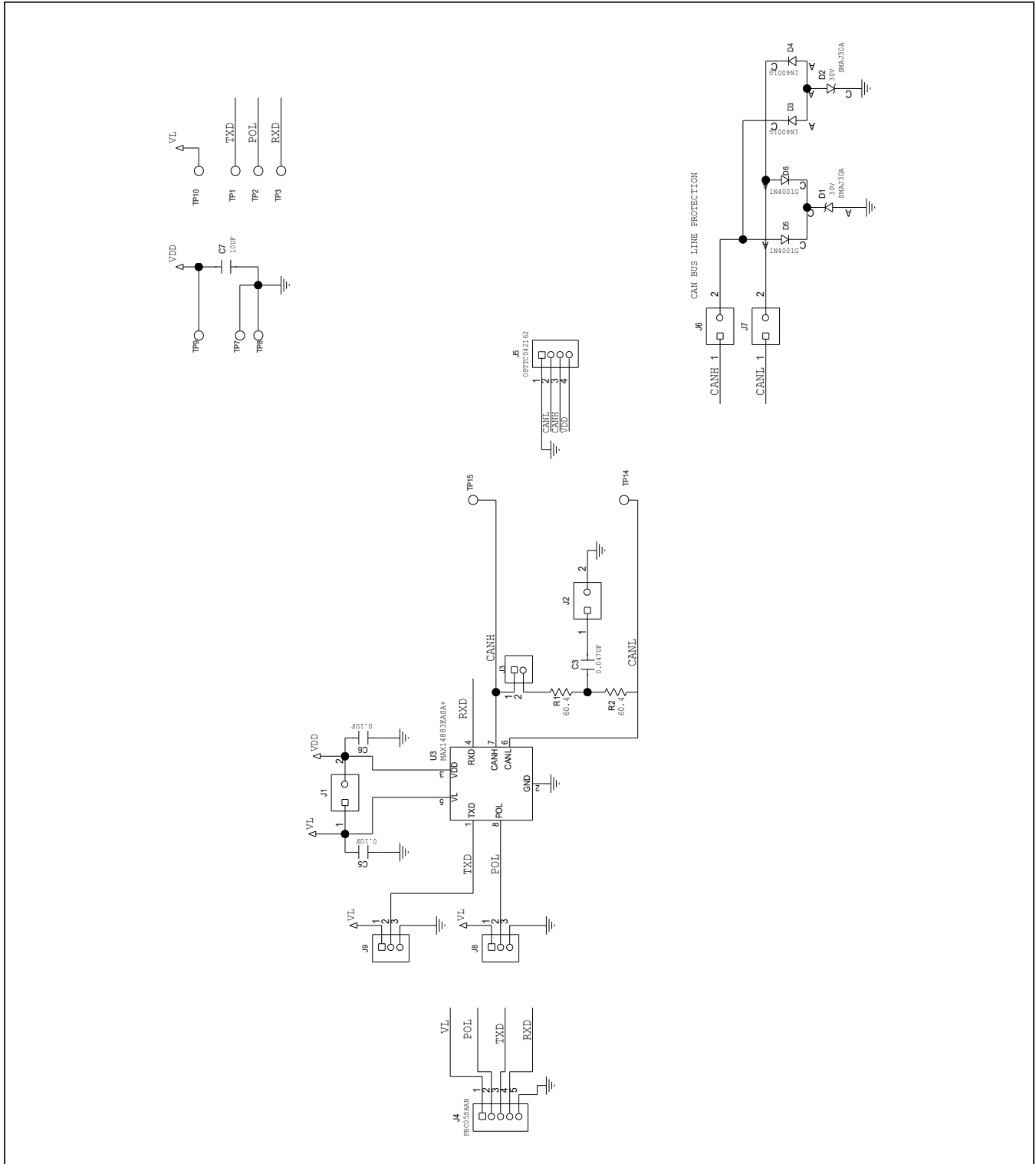

MAX14883E EV Kit PCB Layout Diagrams

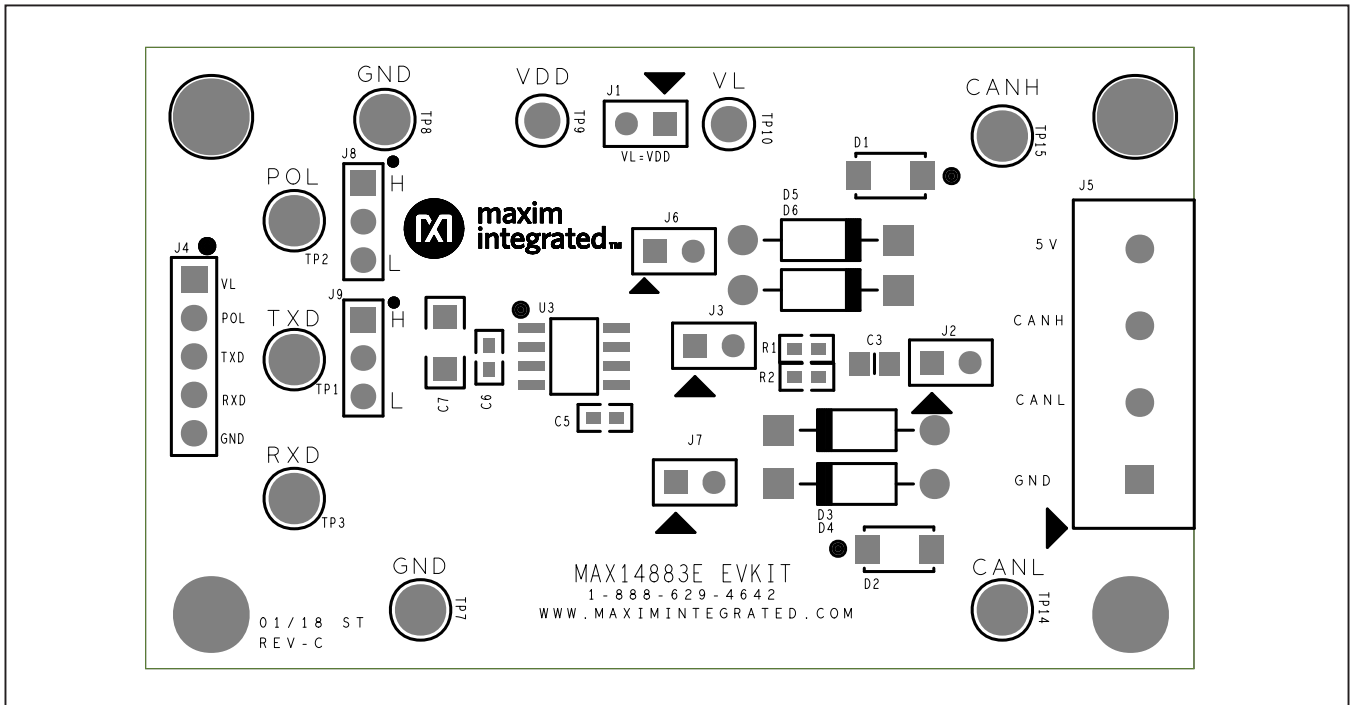

MAX14883E EV Kit—Top Silkscreen

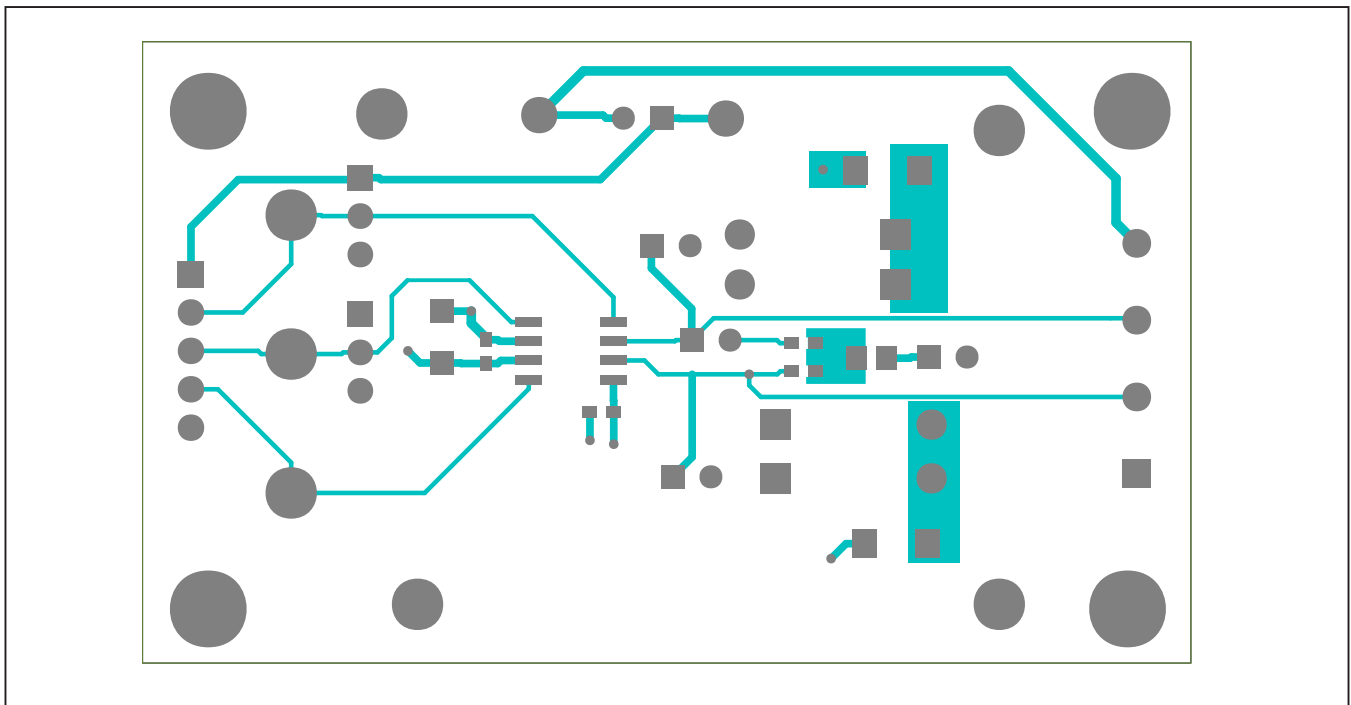

MAX14883E EV Kit—Top Layer

MAX14883E EV Kit PCB Layout Diagrams (continued)

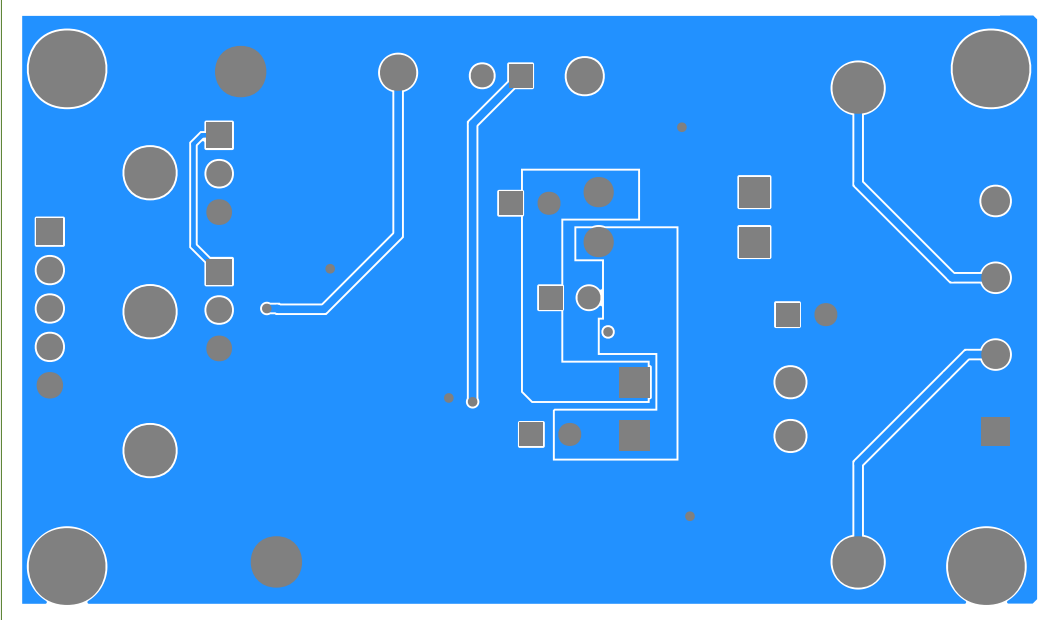

MAX14883E EV Kit— Bottom Layer

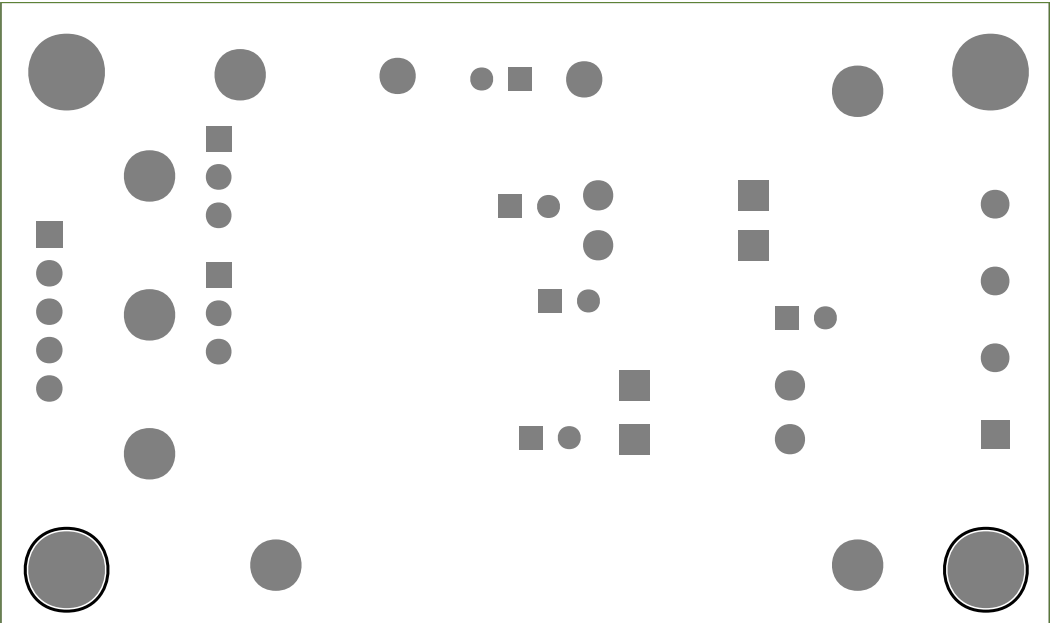

MAX14883E EV Kit—Bottom Silkscreen

Revision History

REVISION NUMBER	REVISION DATE	DESCRIPTION	PAGES CHANGED
0	3/17	Initial release	—
1	9/17	Updated bill of materials, PCB layout diagrams, and schematic	3–6
2	12/18	Updated all sections and corrected typo	1–6

For pricing, delivery, and ordering information, please visit Maxim Integrated's online storefront at <https://www.maximintegrated.com/en/storefront/storefront.html>.

Maxim Integrated cannot assume responsibility for use of any circuitry other than circuitry entirely embodied in a Maxim Integrated product. No circuit patent licenses are implied. Maxim Integrated reserves the right to change the circuitry and specifications without notice at any time.