

# PSR-MC42

## Safety relay for emergency stop, safety door and light grid monitoring

Data sheet  
108719\_en\_00

© PHOENIX CONTACT 2018-12-10



### 1 Description

#### Intended Use

The safety relay is used to monitor safety-related signal generators and to control actuators. The safety relay monitors two sensor circuits. The sensor circuits can be designed as single-channel or two-channel circuits. When at least one sensor circuit is interrupted, the safety relay initiates the safe state. The safety relay interrupts circuits in a safety-related way.

#### Possible signal generators

- Emergency stop button
- Door locking mechanisms
- Light grids

#### Contact type

- 2 sensor circuits
- 2 undelayed enabling current paths
- 1 digital signal output
- I/O link interface

The enabling current paths drop out without delay according to stop category 0 (EN 60204-1).

#### Control

- Single or two channel
- Automatic or manual, monitored start

#### Achievable safety integrity

- Suitable up to category 4, PL e (EN ISO 13849-1), SILCL 3 (EN 62061)

#### Additional features

- Diagnostic data via IO-Link in combination with PSR-CT safety switches
- Cross circuiting detection
- Option of screw or spring-cage terminal blocks for plug-in
- 17.5 mm housing width

#### Approvals



#### **WARNING: Risk of electric shock**

Observe the safety regulations and installation notes in the corresponding section.



Make sure you always use the latest documentation.

It can be downloaded from the product at [phoenixcontact.net/products](https://www.phoenixcontact.net/products).



This document is valid for the products listed in the "Ordering data".

This document meets the same requirements as the original operating instructions with respect to the contents.

---

<b>2</b>	<b>Table of contents</b>	
1	Description .....	1
2	Table of contents .....	2
3	Ordering data .....	3
4	Technical data .....	4
5	Notes regarding documentation .....	9
6	Safety regulations and installation notes.....	10
7	Function description .....	12
8	Function and time diagrams .....	15
9	Basic circuit diagram .....	16
10	Derating.....	17
11	Load curve.....	17
12	Operating and indication elements .....	18
13	Mounting and removing .....	19
14	Wiring .....	19
15	Startup.....	21
16	Calculating the power dissipation .....	22
17	Function test/proof test .....	22
18	Device diagnostics .....	23
19	IO-Link communication and diagnostic data.....	28
20	Application examples .....	33
21	Attachment .....	35

### 3 Ordering data

Description	Type	Order No.	Pcs./Pkt.
Safety relay with IO-Link for emergency stop, safety doors, and light grids, up to SILCL 3, Cat. 4, PL e, 2 sensor circuits, automatic or manual, monitored start, 2 enabling current paths, 1 signal output, $U_S = 24$ V DC, plug-in screw terminal block	PSR-MC42-2NO-1DO-24DC-SC	2702901	1
Safety relay with IO-Link for emergency stop, safety doors, and light grids, up to SILCL 3, Cat. 4, PL e, 2 sensor circuits, automatic or manual, monitored start, 2 enabling current paths, 1 signal output, $U_S = 24$ V DC, plug-in spring-cage terminal block	PSR-MC42-2NO-1DO-24DC-SP	2702902	1
Accessories	Type	Order No.	Pcs./Pkt.
Proximity safety circuit up to Cat. 4, PL e (EN ISO 13849), SIL 3 (IEC 61508), unicode sensor with RFID coding, model 4 (EN ISO 14119), automatic or manual start, integrated diagnostics, 24 V DC supply, IP69K, M12 connector	PSR-CT-C-SEN-1-8	2702972	1
Proximity safety circuit up to Cat. 4, PL e (EN ISO 13849), SIL 3 (IEC 61508), multicode sensor with RFID coding, model 4 (EN ISO 14119), automatic or manual start, integrated diagnostics, 24 V DC supply, IP69K, M12 connector	PSR-CT-M-SEN-1-8	2702975	1
Proximity safety circuit up to Cat. 4, PL e (EN ISO 13849), SIL 3 (IEC 61508), fixcode sensor with RFID coding, model 4 (EN ISO 14119), automatic or manual start, integrated diagnostics, 24 V DC supply, IP69K, M12 connector	PSR-CT-F-SEN-1-8	2702976	1
Proximity safety circuit up to Cat. 4, PL e (EN ISO 13849), SIL 3 (IEC 61508), coded actuator, compatible with all sensor coding types, supplied inductively via the sensor, IP69K	PSR-CT-C-ACT	2702973	1

## 4 Technical data

### Hardware/firmware version

HW/FW  $\geq 00/100$

The technical data and safety characteristics are valid as of the specified HW/FW version.

### Supply

Designation	A1/A2
Rated control circuit supply voltage $U_S$	24 V DC -20 % / +25 % (provide external protection)
Rated control supply current $I_S$	typ. 60 mA
Power consumption at $U_S$	typ. 1.44 W
Inrush current	typ. 2.5 A ( $\Delta t = 500 \mu s$ at $U_S$ )
Filter time	1 ms (at A1 in the event of voltage dips at $U_S$ )
Protective circuit	Serial protection against polarity reversal Suppressor diode

### IO-Link ports: Class A

Number of ports	1
Connection method	Screw connection/ Spring-cage connection
Connection technology	3-wire
Specification	Version 1.1
Transmission speed	230 kbps (COM3)
Cycle Time	5 ms
Process data update	5 ms
Amount of process data	max. 31 Byte (Input data) max. 16 Byte (Output data)

### IO-Link port supply: L+/L-

Nominal voltage for I/O supply	24 V DC -20 % / +25 % (is provided via the IO-Link interface of the IO-Link master.)
Current consumption	typ. 16 mA
Protective circuit	Serial protection against polarity reversal Suppressor diode

### IO-Link switching and communication cable: C/Q

Number of inputs	1
Protective circuit	Suppressor diode

### Digital inputs: Sensor circuit S0

Number of inputs	2 (safety-related sensor inputs: S12, S22)
Description of the input	NPN (S12), NPN/PNP (S22)
Input voltage range "0" signal	0 V DC ... 5 V DC (S12) For S22, see note in "Signal generator connection versions" section.
Input current range "0" signal	0 mA ... 2 mA (S12, S22)
Input voltage range "1" signal	11 V DC ... 30 V DC

<b>Digital inputs: Sensor circuit S0</b>	
Inrush current	< 5 mA (typ. with $U_S$ at S12, $\Delta t = 150$ ms) < 5 mA (typically with $U_S$ at S22/24 V, $\Delta t = 500$ $\mu$ s) > -5 mA (typically with $U_S$ at S22/0 V, $\Delta t = 500$ $\mu$ s)
Current consumption	< 5 mA (Typically with $U_S$ at S12) < 5 mA (typically with $U_S$ at S22/24 V) > -5 mA (typically with $U_S$ at S22/0 V)
Filter time	1.5 ms (Test pulse width of low test pulses) Test pulse rate = 5 x Test pulse width Deactivate switch-on pulses/light tests for safety applications.
Max. permissible overall conductor resistance	150 $\Omega$
Concurrency input 1/2	$\infty$
Protective circuit	Suppressor diode
<b>Digital inputs: Sensor circuit S1</b>	
Number of inputs	2 (safety-related sensor inputs: S32, S34)
Description of the input	NPN
Input voltage range "0" signal	0 V DC ... 5 V DC
Input current range "0" signal	0 mA ... 2 mA
Input voltage range "1" signal	11 V DC ... 30 V DC
Inrush current	< 20 mA (typically with $U_S$ )
Current consumption	< 5 mA (typically with $U_S$ )
Filter time	max. 1.5 ms (Test pulse width of low test pulses) Test pulse rate = 5 x Test pulse width Deactivate switch-on pulses/light tests for safety applications.
Max. permissible overall conductor resistance	150 $\Omega$
Concurrency input 1/2	$\infty$
Protective circuit	Suppressor diode
<b>Digital inputs: Diagnostic input</b>	
Number of inputs	1 (non-safety-related diagnostic input: DGN)
Current consumption	typ. 30 mA
Protective circuit	Suppressor diode
<b>Digital inputs: Start circuit</b>	
Number of inputs	1 (Start input: S34)
Description of the input	NPN (manual start), PNP (autostart)
Input voltage range "1" signal	19.2 V DC ... 30 V DC (manual start, autostart: 0 V)
Inrush current	< 10 mA (typically with $U_S$ , $\Delta t = 100$ ms)
Current consumption	< 5 mA (typically with $U_S$ at S34/24 V) > -5 mA (typically with $U_S$ at S34/0 V)
Max. permissible overall conductor resistance	150 $\Omega$
Protective circuit	Suppressor diode

<b>Relay outputs: Enabling current path</b>	
Number of outputs	2 (safety-related N/O contacts: 13/14, 23/24)
Output description	2 NO contacts each in series, without delay, floating
Contact material	AgSnO <sub>2</sub>
Switching voltage	min. 12 V AC/DC max. 250 V AC/DC (Observe the load curve)
Limiting continuous current	6 A
Inrush current	min. 3 mA max. 6 A
Sq. Total current $I_{TH}^2 = I_1^2 + I_2^2 + \dots + I_N^2$	72 A <sup>2</sup> (observe derating)
Switching capacity	min. 60 mW
Switching frequency	0.5 Hz
Mechanical service life	10x 10 <sup>6</sup> cycles
Switching capacity according to IEC 60947-5-1	4 A (24 V (DC13)) 5 A (250 V (AC15))
Output fuse	6 A gL/gG 4 A gL/gG (for low-demand applications)
<b>Alarm outputs</b>	
Designation	M1
Number of outputs	1 (non-safety-related)
Output description	PNP
Voltage	approx. 22 V DC (U <sub>s</sub> - 2 V)
Current	max. 100 mA
Maximum inrush current	500 mA (Δt = 1 ms at U <sub>s</sub> )
Protective circuit	Suppressor diode
<b>Times</b>	
Typical starting time with U <sub>s</sub>	< 250 ms (when controlled via A1)
Typical response time at U <sub>s</sub>	< 220 ms (automatic start) < 175 ms (manual, monitored start)
Typical release time with U <sub>s</sub>	< 20 ms (on demand via the sensor circuit) < 20 ms (on demand via A1)
Restart time	< 1 s (Boot time)
Recovery time	< 500 ms
<b>General data</b>	
Relay type	Electromechanical relay with forcibly guided contacts in accordance with IEC/EN 61810-3 (EN 50205)
Nominal operating mode	100% operating factor
Degree of protection	IP20
Min. degree of protection of inst. location	IP54
Mounting type	DIN rail mounting
Mounting position	vertical or horizontal
Assembly instructions	See derating curve

<b>General data</b>		
Type of housing	PBT yellow	
Operating voltage display	1 x green, yellow, red LED	
Status display	5 green LEDs	
Air clearances and creepage distances between the power circuits	according to DIN EN 60947-1	
Rated surge voltage/insulation See "Insulation coordination"	Basic insulation 4 kV between all current paths and housing Safe isolation, reinforced insulation 4 kV between input circuit and enabling current path (13/14) and enabling current path (23/24)	
Degree of pollution	2	
Overvoltage category	II	
Maximum power dissipation for nominal condition	6.45 W ( $U_S = 30 \text{ V}$ , $U_L = 30 \text{ V}$ , $I^2 = 72 \text{ A}^2$ )	
Note on power dissipation	See "Calculating the power dissipation"	
<b>Dimensions</b>	<b>Screw connection</b>	<b>Spring-cage connection</b>
W x H x D	17.5 x 112.2 x 114.5 mm	17.5 x 116.6 x 114.5 mm
<b>Connection data</b>	<b>Screw connection</b>	<b>Spring-cage connection</b>
Conductor cross section, solid	0.2 mm <sup>2</sup> ... 2.5 mm <sup>2</sup>	0.2 mm <sup>2</sup> ... 1.5 mm <sup>2</sup>
Conductor cross section, flexible	0.2 mm <sup>2</sup> ... 2.5 mm <sup>2</sup>	0.2 mm <sup>2</sup> ... 1.5 mm <sup>2</sup>
Conductor cross section AWG/kcmil	24 ... 12	24 ... 16
Stripping length	7 mm	8 mm
Screw thread	M3	
Torque	0.5 Nm ... 0.6 Nm	
<b>Ambient conditions</b>		
Ambient temperature (operation)	-25 °C ... 60 °C (observe derating)	
Ambient temperature (storage/transport)	-40 °C ... 85 °C	
Max. permissible relative humidity (operation)	75 % (on average, 85% infrequently, non-condensing)	
Max. permissible humidity (storage/transport)	75 % (on average, 85% infrequently, non-condensing)	
Information on operating height	See the "Using PSR devices at altitudes greater than 2000 m above sea level" section	
Shock	15g	
Vibration (operation)	10 Hz ... 150 Hz, 2g	
<b>Conformance/Approvals</b>		
Conformance	CE-compliant	
The full EC Declaration of Conformity can be downloaded for the product at <a href="http://phoenixcontact.net/products">phoenixcontact.net/products</a> .		
Approvals		
<b>Safety data</b>		
Stop category according to IEC 60204	0	

**Safety parameters for IEC 61508 - High demand**

Equipment type	Type A
HFT	1
SIL	3
PFH <sub>D</sub>	1.00 x 10 <sup>-9</sup> (4 A DC13; 5 A AC15; 8760 switching cycles/year)
Demand rate	< 12 Months
Proof test interval	240 Months
Duration of use	240 Months

**Safety parameters for IEC 61508 - Low demand**

Equipment type	Type A
HFT	1
SIL	3
PFD <sub>avg</sub>	3.76 x 10 <sup>-5</sup>
Proof test interval	36 Months
Duration of use	240 Months

**Safety characteristic data according to EN ISO 13849**

Category	4
Performance level	e (4 A DC13; 5 A AC15; 8760 switching cycles/year)
Duration of use	240 Months
For applications in PL e, the required demand rate for the safety function is once per month.	

**Safety parameters for EN 62061**

SILCL	3
For applications in SILCL 3 the required demand rate for the safety function is once per month.	



## 5 Notes regarding documentation

### 5.1 Explanation of symbols used and signal words



This is the safety alert symbol. It is used to alert you to potential personal injury hazards. Obey all safety measures that follow this symbol to avoid possible injury or death.

There are three different categories of personal injury that are indicated with a signal word.

- DANGER** This indicates a hazardous situation which, if not avoided, will result in death or serious injury.
- WARNING** This indicates a hazardous situation which, if not avoided, could result in death or serious injury.
- CAUTION** This indicates a hazardous situation which, if not avoided, could result in minor or moderate injury.



This symbol together with the signal word **NOTE** and the accompanying text alert the reader to a situation which may cause damage or malfunction to the device, hardware/software, or surrounding property.



This symbol and the accompanying text provide the reader with additional information or refer to detailed sources of information.

### 5.2 Validity

This data sheet is valid for the described product(s) from the hardware/firmware version specified in the technical data.

### 5.3 Target group

This data sheet is therefore aimed at:

- Qualified personnel who plan and design safety equipment for machines and systems and are familiar with regulations governing occupational safety and accident prevention.
- Qualified personnel who install and operate safety equipment in machines and systems.

### Qualified personnel:

Qualified personnel are people who, because of their education, experience, and instruction and their knowledge of relevant standards, regulations, accident prevention, and service conditions, have been authorized by those responsible for the safety of the system to carry out any required operations and who are able to recognize and avoid any possible dangers.

### Requirements:

Knowledge of the following topics is required:

- Handling safety components
- Valid EMC regulations
- Valid regulations governing occupational safety and accident prevention

## 6 Safety regulations and installation notes



### **WARNING: Death, serious personal injury or damage to equipment**

Depending on the application, incorrect handling of the device may pose serious risks for the user or cause damage to equipment.

- Observe all the safety notes and warning instructions provided in this chapter and elsewhere in this document.

### **General**

- Observe the safety regulations of electrical engineering and industrial safety and liability associations.

Disregarding these safety regulations may result in death, serious personal injury or damage to equipment.

### **Direct/indirect contact**

- Protection against direct and indirect contact according to VDE 0100 Part 410 must be ensured for all components connected to the system.

In the event of an error, parasitic voltages must not occur (single-fault tolerance).

### **Power supply units for 24 V supply**

- Only use power supply units with safe isolation and SELV/PELV according to EN 50178/VDE 0160.
- Protect the 24 V area with a suitable external fuse.
- Make sure that the power supply unit is able to supply **four times** the nominal current of the external fuse, to ensure that it trips in the event of an error.
- Make sure that the output voltage of the voltage supply does not exceed 32 V even in the event of error.

### **Startup, mounting, and modifications**

Startup, mounting, modifications, and upgrades may only be carried out by an electrically skilled person.

- Before working on the device, disconnect the power.
- Carry out wiring according to the application. Refer to the “Application examples” section for this.

Reliable operation is only ensured if the device is installed in housing protected from dust and humidity.

- Install the device in housing protected from dust and humidity (min. IP54).

### **In operation**

During operation, parts of electrical switching devices carry hazardous voltages.

- Protective covers must not be removed when operating electrical switching devices.

For emergency stop applications, automatic startup of the machine can pose serious risks for the user.

- The machine must be prevented from restarting automatically by a higher-level controller.

With the manual, monitored reset device, a machine start may not be triggered in accordance with EN ISO 13849-1.

Inductive loads can lead to welded relay contacts.

- Connect a suitable and effective protective circuit to inductive loads.
- Implement the protective circuit parallel to the load and not parallel to the switch contact.

Magnetic fields can influence the device. The magnetic field strength of the environment must not exceed 30 A/m.

- Do not use the device in the vicinity of strong magnetic fields (e.g., caused by transformers or magnetic iron).

Noise emission may occur when operating relay modules. Wireless reception may be disrupted in residential areas.

The device is a Class A product.

- Observe the requirements for noise emission for electrical and electronic equipment (EN 61000-6-4).
- Implement appropriate precautions against noise emission.

### Faulty devices

The devices may be damaged following an error. Correct operation can no longer be ensured.

- In the event of an error, replace the device.

Only the manufacturer or their authorized representative may perform the following activities. Otherwise the warranty is invalidated.

- Repairs to the device
- Opening the housing

### Taking out of service and disposal

- Dispose of the device in accordance with environmental regulations.
- Make sure that the device can never be reused.

## 6.1 Safety of machines or systems

### Draw up and implement a safety concept

The machine or system manufacturer and the operator are responsible for the safety of the machine or system and the application in which the machine or system is used. In order to use the device described in this document, you must have drawn up an appropriate safety concept for your machine or system. This includes a risk assessment in accordance with the directives and standards specified in the EC Declaration of Conformity, as well as other standards.



The EC Declaration of Conformity can be downloaded for the product at [phoenixcontact.net/products](http://phoenixcontact.net/products).

### Risk assessment, validation and function test

- Before using the device, perform a risk assessment on the machine or system.
- Validate your entire safety system.
- Carry out a new validation every time you make a safety-related modification.
- Perform a function test on a regular basis.

### Achievable safety integrity

Functional safety is guaranteed for the device as a single component. However, this does not guarantee functional safety for the entire machine or system. In order to achieve the desired safety level for the entire machine or system, define the safety requirements for the machine or system as well as how to implement them from both a technological and organizational perspective.

## 7 Function description

### 7.1 Safety instrumented function

#### 7.1.1 Monitoring of the sensor circuits

The safety relay monitors two sensor circuits. The sensor circuits can be designed as single-channel or two-channel circuits.

The safety relay can only be operated using both sensor circuits. If only one sensor circuit is used, the second sensor circuit must be bridged.

The sensor circuits evaluate various signal generators.

- **Sensor circuit S0** with cross-circuit detection, suitable for single-channel or two-channel safety sensors
- **Sensor circuit S1** suitable for OSSD signals, cross-circuit detection by signal generator

☞ See “Block diagram” section.

#### Single-channel sensor circuit

The sensor circuit is not designed with redundancy.

The safety relay does not detect short and cross-circuits in the sensor circuit.

#### Two-channel sensor circuit

The connection of the two-channel sensor circuit is equivalent.

With the corresponding wiring, the safety relay detects short and cross-circuits in the sensor circuit.

☞ See “Signal generator connection versions” section.

### 7.1.2 Startup behavior

#### Start conditions

- Both sensor circuits are closed
- Enable signal is present

☞ See “Enable principle” section.

#### Automatic start

If the start conditions are met, the device starts automatically.

#### Manual, monitored start

When the start conditions are met, the device starts once the start circuit has been closed and opened again by pressing and releasing the reset button.

A connected reset button is monitored.

☞ See “Start and feedback circuit connection versions” section.

### 7.1.3 Safe shutdown

If at least one sensor circuit is interrupted, the enabling current paths open without delay.

When the enabling current paths are open, the device is in the safe state.

## 7.2 IO-Link communication and functions

The safety relay is an IO-Link device.

Communication via IO-Link offers cyclic and acyclic data exchange.



The cyclic and acyclic data can be found in the "IO-Link communication and diagnostic data" section.

The following information is transmitted:

- Device information for the safety relay (electronic rating plate, device states)
- Status information regarding connected PSR-CT safety switches

In addition, IO-Link communication can be used for the following functions:

- Enable principle: non-safety-related control of the enabling current paths of the safety relay
- Chain reset: the PSR-CT safety switch chain is reset

### 7.2.1 Enable principle

The enabling current paths of the safety relay can be controlled via a non-safety-related enable signal by means of IO-Link communication. It is not necessary to press the reset button again.

When the safety relay detects an IO-Link connection, the enable signal must be set accordingly for operation via IO-Link communication.

This optional function is not safety-related and is subordinate to the safety instrumented function of the safety relay. This means that the non-safety-related enable signal cannot start the enabling current paths of the safety relay while the safety-related requirements for the sensor circuits and start circuit of the safety relay are not met.

The enable signal is controlled via cyclic data exchange.

### 7.2.2 Chain reset

A chain reset can be used to restart all PSR-CT safety switches in a chain centrally via IO-Link communication.

This function facilitates a return to the ready state after troubleshooting.

The chain reset command is controlled via cyclic data exchange.

## 7.3 Communication and functions with PSR-CT safety switches

### 7.3.1 Diagnostic Data

The DGN connection on the safety relay allows you to connect the diagnostic cable for a PSR-CT safety switch chain.

The DGN link represents non-safety-related communication between the safety relay and the safety switches.

When the safety switch chain is started up, the switches perform "head-counting" to address the individual switches. Addressing enables clear diagnostics for each safety switch.

Following a restart, the safety relay synchronizes with the safety switch chain. All safety switches are then available for communication and diagnostics.

### 7.3.2 Hot plugging – Swapping a PSR-CT safety switch

It is possible to swap a safety switch within a PSR-CT safety switch chain during operation. This process is known as "hot plugging".

In order to ensure that addressing is performed correctly after a swap, only one safety switch can be swapped at a time (1:1 swap).

If another safety switch needs to be swapped, the required switch-on delay of the previously swapped switch must be taken into consideration.



Observe the technical data for the PSR-CT safety switches in the corresponding product documentation.

## 7.4 Functions of signal output M1

### 7.4.1 When using IO-Link communication

When an IO-Link connection is detected, signal output M1 behaves as follows:

The signal level of the signal output is not equivalent to the state of the enabling current paths of the safety relay.

When the enabling current paths are closed, the signal output is inactive (Low level).

When at least one enabling current path is open, the signal output is active (High level).

### 7.4.2 Without IO-Link communication: serial diagnostics

When no IO-Link connection is detected, the safety relay offers serial diagnostics via signal output M1.

Serial diagnostics transmits the following non-safety-related information:

- State of sensor circuits and enabling current paths as well as the reset demand of the safety relay
- State of connected PSR-CT safety switches (16 switches)

The information transmitted via serial diagnostics can be evaluated in the higher-level controller.



The actual diagnostic data can be found in the “Serial diagnostics via signal output M1” section.

### Principle of serial diagnostics

The signal for serial diagnostics is inverted, i.e., a logical “0” is represented by 24 V and a logical “1” by 0 V.

Data transmission commences with a start bit. The start bit consists of a rising edge from the idle state, followed by a High signal for a symbol duration (bit length) of 60 ms.

The diagnostic data is then transmitted after this.

An even parity bit is connected to the diagnostic data for error detection.

Data transmission ends with a stop bit. The stop bit is followed by a rest period of 2800 ms.

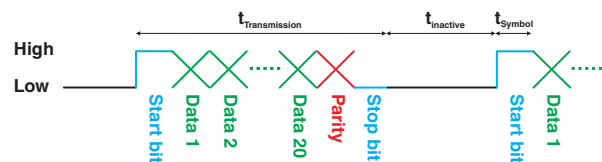

Figure 1 Data transmission serial diagnostics

#### Key:

$t_{\text{Transmission}}$	Transmission time = 1380 ms
$t_{\text{inactive}}$	Idle state = 2800 ms
$t_{\text{Symbol}}$	Symbol duration = 60 ms

### Evaluation in the controller



For reliable diagnostics, parameterize a constant cycle time of < 20 ms for the PLC input.

## 8 Function and time diagrams



All illustrated diagrams relate to the application with IO-Link.

### 8.1 Time diagram for automatic start

#### 8.1.1 Continuous autostart

- Permanent High signal at S34

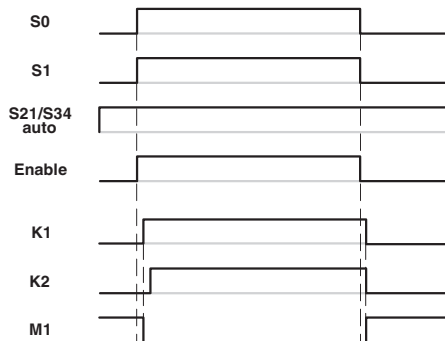

Figure 2 Time diagram for automatic start

#### 8.1.2 Autostart pulse

- Start on rising edge at S34

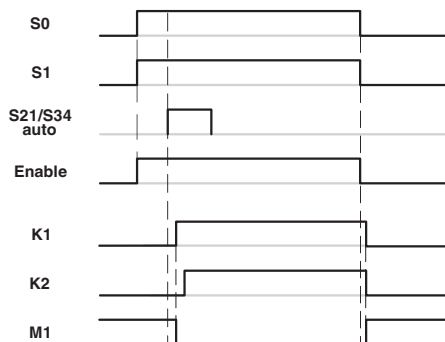

Figure 3 Time diagram for automatic start

### 8.2 Time diagram for manual, monitored start

- Start on falling edge at S34

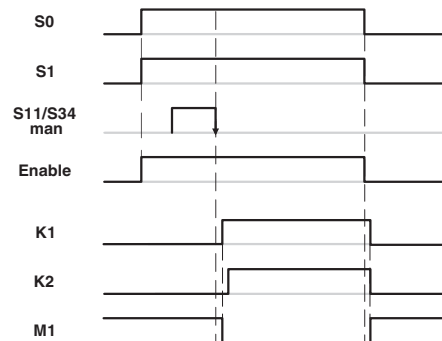

Figure 4 Time diagram for manual, monitored start

### 8.3 Time diagram enable principle

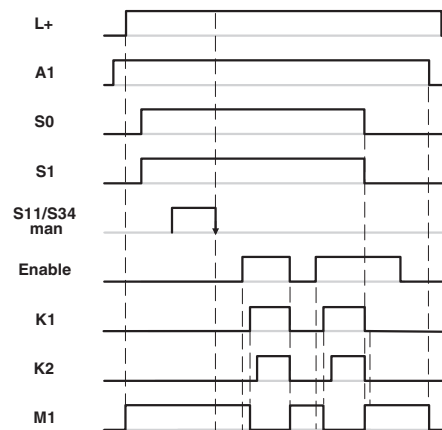

Figure 5 Time diagram enable principle

#### Key:

<b>S0/S1</b>	Sensor circuits
<b>S21/S34 auto</b>	Start circuit for autostart
<b>S11/S34 man</b>	Manual start circuit, monitored start
<b>K1/K2</b>	Output circuits
<b>M1</b>	Digital alarm output
<b>L+</b>	IO-Link power supply
<b>A1</b>	Power supply
<b>Enable</b>	Enable signal via IO-Link

## 9 Basic circuit diagram

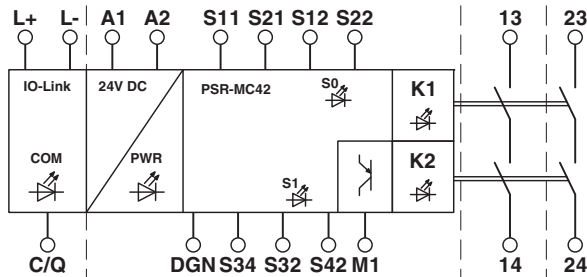

Figure 6 Block diagram

### Key:

<b>L+/L-</b>	IO-Link power supply
<b>C/Q</b>	IO-Link switching and communication cable
<b>A1</b>	24 V DC power supply
<b>A2</b>	0 V power supply
<b>S11</b>	Power supply output for S12
<b>S21</b>	Power supply input for S22
<b>S12</b>	Input sensor circuit S0 (channel 1)
<b>S22</b>	Input sensor circuit S0 (channel 2)
<b>DGN</b>	Diagnostic input safety switch
<b>S34</b>	Start circuit
<b>S32</b>	OSSD input sensor circuit S1 (channel 1)
<b>S42</b>	OSSD input sensor circuit S1 (channel 2)
<b>M1</b>	Digital alarm output
<b>13/14</b>	Undelayed enabling current paths
<b>23/24</b>	

### 9.1 Insulation coordination

	A1/A2, logic	IO-Link	13/14	23/24	Housing
A1/A2, logic	-	0.5 kV ST	4 kV ST	4 kV ST	4 kV BI
IO-Link	-	-	4 kV ST	4 kV ST	4 kV BI
13/14	-	-	-	4 kV ST	4 kV BI
23/24	-	-	-	-	4 kV BI
Housing	-	-	-	-	-

### Key:

<b>BI</b>	Basic insulation
<b>ST</b>	Safe isolation
<b>Logic</b>	Sensor and start circuits, signal output diagnostic input
<b>IO-Link</b>	IO-Link power supply, IO-Link switching and communication cable



#### **WARNING: loss of electrical safety**

Take measures outside the device to limit transient surge voltages to the respective value for overvoltage category II.



## 10 Derating

### 10.1 Vertical or horizontal mounting position

The derating curve applies for the following conditions:

- Mounting on a vertical or horizontal DIN rail
- Devices mounted next to each other without spacing
- at  $U_S$  up to max. 30 V DC

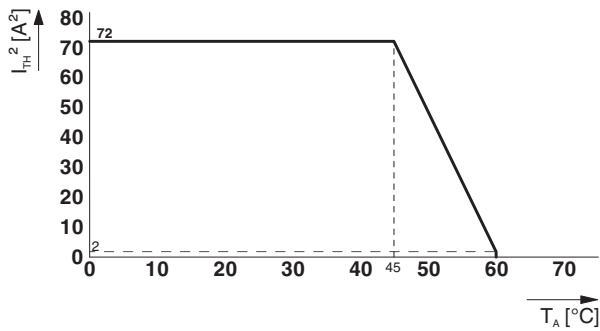

Figure 7 Derating curve

## 11 Load curve

### 11.1 Ohmic and inductive load

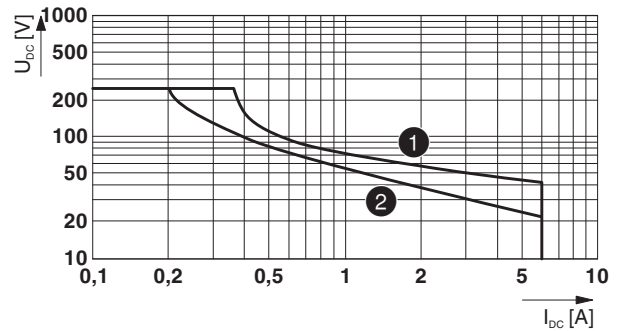

Figure 8 Relay load curve - ohmic and inductive load

Key:

- |   |                |               |
|---|----------------|---------------|
| ① | Ohmic load     | $L/R = 0$ ms  |
| ② | Inductive load | $L/R = 40$ ms |

## 12 Operating and indication elements

### 12.1 Connection versions

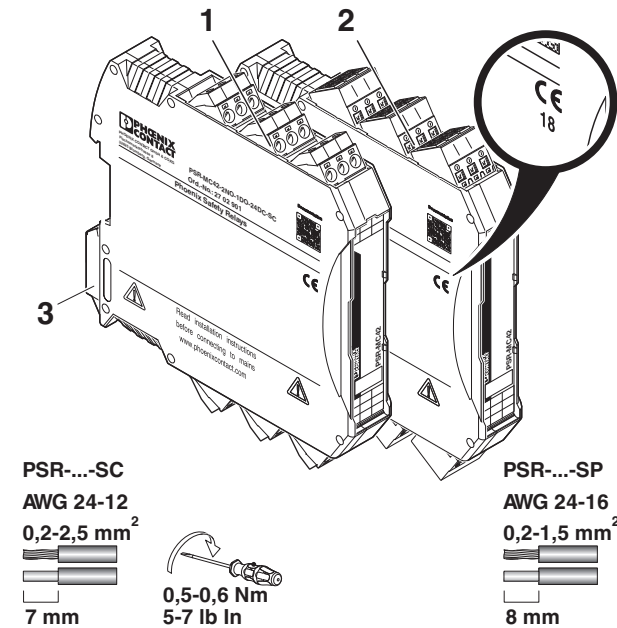

- 1 COMBICON plug-in screw terminal block
- 2 COMBICON plug-in spring-cage terminal block
- 3 Metal lock for fixing to DIN rail



The year the device was constructed can be found underneath the CE designation on the housing.

Figure 9 Connection versions

### 12.2 Connection assignment

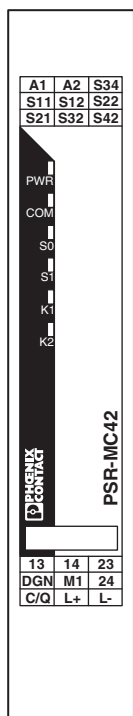

- A1** 24 V DC power supply
- A2** 0 V power supply
- S11** Power supply output for S12
- S21** Power supply input for S22
- S12** Input sensor circuit S0 (channel 1)
- S22** Input sensor circuit S0 (channel 2)
- S34** Start circuit
- S32** OSSD input sensor circuit S1 (channel 1)
- S42** OSSD input sensor circuit S1 (channel 2)
- PWR** Power LED (green, yellow, red)
- COM** Status indicator IO-Link communication; LED (green)
- S0** Status indicator sensor circuit S0; LED (green)
- S1** Status indicator sensor circuit S1; LED (green)
- K1** Status indicator safety circuit; LED (green)
- K2** Status indicator safety circuit; LED (green)
- 13/14** Enabling current path, undelayed
- 23/24** Enabling current path, undelayed
- DGN** Diagnostic input safety switch
- M1** Digital alarm output
- C/Q** IO-Link switching and communication cable
- L+/L-** IO-Link power supply

### 13 Mounting and removing

- Mount the device on a 35 mm DIN rail according to EN 60715.
- To remove the device, use a screwdriver to release the snap-on foot.

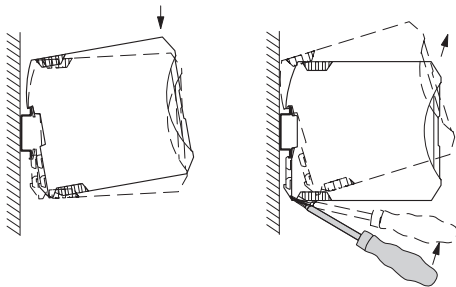

Figure 10 Mounting and removing

### 14 Wiring

- Connect the cables to the connection terminal blocks using a screwdriver.

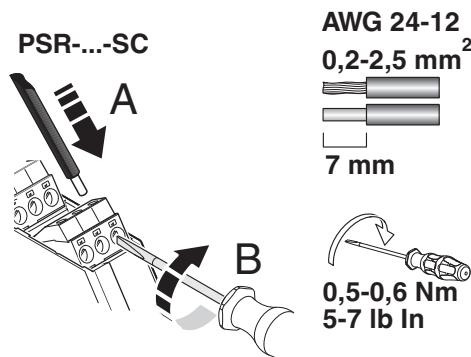

Figure 11 Connecting the cables for PSR-...-SC (screw terminal block)

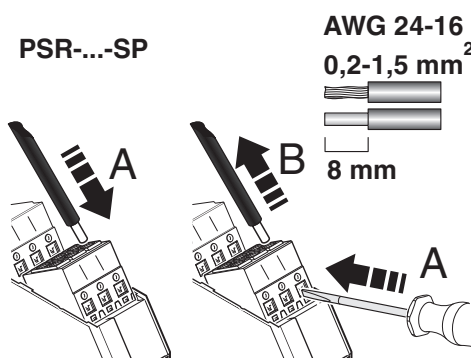

Figure 12 Connecting the cables for PSR-...-SP (spring-cage terminal block)



It is recommended that ferrules are used to connect stranded cables.



For compliance with UL approval, use copper wire that is approved up to 60°C/75°C.

#### 14.1 Signal generator connection versions



The safety relay can only be operated using both sensor circuits. If only one sensor circuit is used, the second sensor circuit must be bridged.

#### Sensor circuit S0

- Connect suitable signal generators to S11/S12/S21/S22.

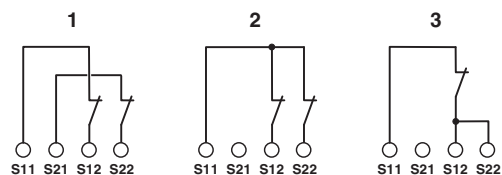

Figure 13 Connection variants signal generator sensor circuit S0

- 1 Two-channel connection with cross-circuit detection
- 2 Two-channel connection without cross-circuit detection
- 3 Single-channel connection



#### WARNING: Risk of automatic machine restart

Low-resistance PLC outputs can be interpreted at the S22 input of the safety relay as a continuous high-signal (permanently on). Therefore, a safe switch-off via a low-resistance PLC output at S22 is not possible.

- Do not use low-resistance PLC outputs at the S22 input.

**Sensor circuit S1**

- Connect suitable signal generators to S32/S42.

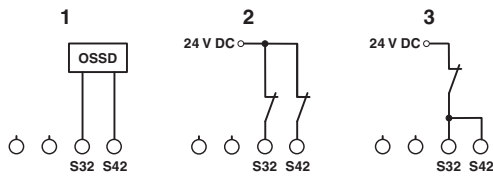

Figure 14 Connection variants sensor circuit S1

- 1 Two-channel connection with **external** cross-circuit detection by the signal generator
- 2 Two-channel connection without cross-circuit detection
- 3 Single-channel connection



Sensor circuit S1 does not offer cross-circuit detection. If cross-circuit detection is required, this must be performed externally via suitable signal generators.

**14.2 Start and feedback circuit connection variants**

**Automatic start**

- Bridge the contacts S21/S34.

**Manual, monitored start**

- Connect a reset button to S11/S34.

A connected reset button is monitored.

**Start and feedback circuit**

- Place the relevant N/C contact in path S21/S34 or S11/S34 to monitor external contactors or extension devices with force-guided contacts.

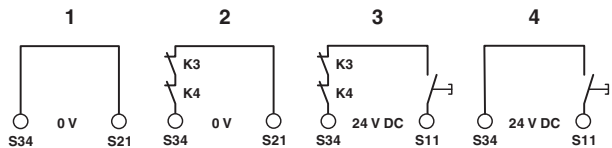

Figure 15 Start and feedback circuit connection variants

- 1 Automatic start
- 2 Automatic start with monitored contact extension
- 3 Manual, monitored start with monitored contact extension
- 4 Manual, monitored start



**WARNING: Risk of automatic machine restart**

If the manual reset function with monitored start is used, a cross-circuit between A2/S21/0 V and the cable from the reset button to S34 can result in automatic machine startup.

This applies in particular for safety functions with increased risk potential.

- Prevent a cross-circuit between A2/S21/0 V and the cable from the reset button to S34 by means of design measures (see error prevention in accordance with EN ISO 13849-2).



**WARNING: Risk of automatic machine restart**

Low-resistance PLC outputs can be interpreted at input S34 of the safety relay as a ground signal and can trigger an autostart.

## 15 Startup

### 15.1 With IO-Link communication

#### Integrating the device description file

- Depending on the number of PSR-CT safety switches that are connected, integrate the corresponding device description file (IODD, FDCML, GSDML) in the engineering tool.
  - See “Device description file” section.
- Download the configuration to the IO-Link master.

#### Starting up safety relays

- Apply the rated control circuit supply voltage (24 V DC) at terminal blocks A1/A2.
- Connect the IO-Link power supply L+/L- and the switching and communication cable C/Q to the corresponding port of the IO-Link master.

The PWR LED lights up green.

The COM LED flashes green then IO-Link communication is established.

- Close the sensor circuits according to their wiring.
  - See “Signal generator connection versions” section.

The S0 and S1 LEDs light up green.

#### Activating the enable signal

- To control the enabling current paths, set the enable signal via the cyclic data item in byte 0, bit 0.
  - See “Cyclic data” section.

#### Automatic start

The enabling current paths 13/14 and 23/24 close.

The K1 and K2 LEDs light up green.

#### Manual, monitored start

- Press the reset button.
- Release the reset button.

The enabling current paths 13/14 and 23/24 close.

The K1 and K2 LEDs light up green.

#### Possible diagnostics

The status information for the individual PSR-CT safety switches and the device information for the safety relay can be processed by means of cyclic data.

See “Cyclic data” section.

### 15.2 Without IO-Link communication

- Apply the rated control circuit supply voltage (24 V DC) at terminal blocks A1/A2.
- Bridge terminal points A1 with L+ and A2 with L-.

The PWR LED lights up green.

The COM LED is off.

- Close the sensor circuits according to their wiring.
  - See “Signal generator connection versions” section.

The S0 and S1 LEDs light up green.

#### Internal enable signal

In the operating mode without IO-Link, the safety relay automatically sets the enable signal internally in the device. It is therefore not possible to control the enabling current paths.

#### Resetting IO-Link mode

If the safety relay was previously operated in IO-Link mode and is then to be used without IO-Link, you must first reset IO-Link mode.

Use the acyclic write service index 250, subindex 0 for this.

See “Write services” section.

On the next restart, the safety relay internally activates the enable signal again after < 1 s, provided IO-Link communication has not been established in the meantime.

### Automatic start

The enabling current paths 13/14 and 23/24 close.

The K1 and K2 LEDs light up green.

### Manual, monitored start

- Press the reset button.
- Release the reset button.

The enabling current paths 13/14 and 23/24 close.

The K1 and K2 LEDs light up green.

### Possible diagnostics

To use serial diagnostics, connect signal output M1 to a digital input of a PLC.



For reliable diagnostics, parameterize a constant cycle time of < 20 ms for the PLC input.  
See "Principle of serial diagnostics" section.

The status information for the individual PSR-CT safety switches and the device information for the safety relay can be processed by means of serial diagnostics.

☰ See "Serial diagnostics via signal output M1" section.

## 16 Calculating the power dissipation



The total power dissipation of the safety relay is based on the input power dissipation and the contact power dissipation for the same and for different load currents.

### Input power dissipation

$$P_{\text{Input}} = U_B^2 / (U_S / I_S)$$

$$P_{\text{IO-Link}} = U_{B,\text{IO-L}}^2 / (U_{\text{IO-L}} / I_{\text{IO-L}})$$

### Contact power dissipation

With the same load currents:

$$P_{\text{Contact}} = n \cdot I_L^2 \cdot 50 \text{ m}\Omega$$

With different load currents:

$$P_{\text{Contact}} = (I_{L1}^2 + I_{L2}^2) \cdot 50 \text{ m}\Omega$$

### Total power dissipation

$$P_{\text{Total}} = P_{\text{Input}} + P_{\text{IO-Link}} + P_{\text{Contact}}$$

therefore

$$P_{\text{Total}} = U_B^2 / (U_S / I_S) + U_{B,\text{IO-L}}^2 / (U_{\text{IO-L}} / I_{\text{IO-L}}) + n \cdot I_L^2 \cdot 200 \text{ m}\Omega$$

or

$$P_{\text{Total}} = U_B^2 / (U_S / I_S) + U_{B,\text{IO-L}}^2 / (U_{\text{IO-L}} / I_{\text{IO-L}}) + (I_{L1}^2 + I_{L2}^2) \cdot 50 \text{ m}\Omega$$

### Key:

<b>P</b>	Power dissipation in mW
<b>U<sub>B</sub></b>	Applied operating voltage
<b>U<sub>S</sub></b>	Rated control circuit supply voltage
<b>I<sub>S</sub></b>	Rated control supply current
<b>U<sub>B,IO-L</sub></b>	Applied IO-Link I/O supply voltage
<b>U<sub>IO-L</sub></b>	Nominal IO-Link I/O supply voltage
<b>I<sub>IO-L</sub></b>	Current consumption for IO-Link port supply
<b>n</b>	Number of enabling current paths used
<b>I<sub>L</sub></b>	Contact load current

## 17 Function test/proof test

To verify the device function, proceed as follows for each individual sensor circuit:

- Demand the safety function by actuating the corresponding safety equipment.
- Check whether the safety function was executed correctly by switching the device on again.

If the device does not switch on again, the proof test failed.



If the proof test contains errors, the device no longer functions correctly.

- Replace the device.

## 18 Device diagnostics



Plausibility errors are deleted when the supply voltage is switched off (power down reset).



In the event of an error or fault that is not listed, please contact Phoenix Contact.

### 18.1 Diagnostics via the LED indicators

#### 18.1.1 General states

##### Key:

- LED OFF
- LED is permanently **green**



##### Behavior of the COM LED

In the operating mode **without** IO-Link, the COM LED is **off**.

In the operating mode **with** IO-Link, the COM LED **flashes** green while IO-Link communication is active.

If the COM LED is off in the operating mode with IO-Link, this means that communication has been lost. In this case, check the IO-Link connection.

No.	LED					State	Notes
	PWR	S0	S1	K1	K2		
1	●	○	○	○	○	No relay has picked up. The sensor circuit is inactive.	-
2	●	●	○	○	○	Only sensor circuit S0 is active.	-
3	●	○	●	○	○	Only sensor circuit S1 is active.	-
4	●	●	●	○	○	The sensor circuits are active. Relays K1 and K2 are ready to start and await reset/start command (S34).	Possible error see error messages
5	●	●	●	●	●	The sensor circuits are active. All relays are picked up.	-

### 18.1.2 Error messages

#### Key:

- LED OFF
- LED is permanently **green**
- LED is permanently **red**
- ☼ LED is flashing **red/yellow slowly**
- ☼ LED is flashing **green/red slowly**
- ☼ LED is flashing **green/yellow slowly**
- ☼ LED is flashing **green slowly**
- ☼ LED is flashing **red slowly**
- ☼ LED is flashing **red quickly**



#### Behavior of the COM LED

In the operating mode **without** IO-Link, the COM LED is **off**.

In the operating mode **with** IO-Link, the COM LED **flashes** green while IO-Link communication is active.

If the COM LED is off in the operating mode with IO-Link, this means that communication has been lost. In this case, check the IO-Link connection.

No.	LED					State	Possible cause	Corrective
	PWR	S0	S1	K1	K2			
1	○	○	○	○	○	The sensor circuits are actively controlled, but no input LEDs are lit up.	No supply voltage at L+/L-.	Check the supply voltage.
2	☼	○	○	○	○	-	Undervoltage at L+/L-.	Check the supply voltage.
3	☼	●	○	○	○	Only sensor circuit S0 is active.	Undervoltage at L+/L-.	Check the supply voltage.
4	☼	○	●	○	○	Only sensor circuit S1 is active.	Undervoltage at L+/L-.	Check the supply voltage.
5	☼	●	●	●	●	The sensor circuits are active. All relays are picked up.	Undervoltage at L+/L-.	Check the supply voltage.
6	☼	○	○	○	○	The sensor circuits are active.	Undervoltage at A1/A2.	Check the supply voltage.
7	☼	☼	●	●	○	Sensor circuit S0 has been deactivated. Safety circuit (K1) is not dropping out.	External error: both channels of sensor circuit S0 were not opened or requested.	Check whether the second channel opens when the sensor is requested.
							Internal error	Perform a power down reset with subsequent function test. <b>If the error occurs again after the function test, replace the device.</b>



No.	LED					State	Possible cause	Corrective
	PWR	S0	S1	K1	K2			
8	☀	☀	●	○	●	Sensor circuit S0 has been deactivated. Safety circuit (K2) is not dropping out.	External error: both channels of sensor circuit S0 were not opened or requested.	Check whether the second channel opens when the sensor is requested.
							Internal error	Perform a power down reset with subsequent function test. <b>If the error occurs again after the function test, replace the device.</b>
9	☀	●	☀	●	○	Sensor circuit S1 has been deactivated. Safety circuit (K1) is not dropping out.	External error: both channels of sensor circuit S1 were not opened or requested.	Check whether the second channel opens when the sensor is requested.
							Internal error	Perform a power down reset with subsequent function test. <b>If the error occurs again after the function test, replace the device.</b>
10	☀	●	☀	○	●	Sensor circuit S1 has been deactivated. Safety circuit (K2) is not dropping out.	External error: both channels of sensor circuit S1 were not opened or requested.	Check whether the second channel opens when the sensor is requested.
							Internal error	Perform a power down reset with subsequent function test. <b>If the error occurs again after the function test, replace the device.</b>
11	☀	☀	○	○	○	Sensor circuits S0 and S1 have been deactivated.	External error: both channels of sensor circuit S0 were not opened or requested.	Check whether the second channel opens when the sensor is requested.
							Internal error	Perform a power down reset with subsequent function test. <b>If the error occurs again after the function test, replace the device.</b>

No.	LED					State	Possible cause	Corrective
	PWR	S0	S1	K1	K2			
12	☀	○	☀	○	○	Sensor circuits S0 and S1 have been deactivated.	External error: both channels of sensor circuit S1 were not opened or requested.	Check whether the second channel opens when the sensor is requested.
							Internal error	Perform a power down reset with subsequent function test. <b>If the error occurs again after the function test, replace the device.</b>
13	☀	●	●	○	○	The sensor circuits are active. The reset/start circuit (S34) is/was activated. The safety circuit (K1 and K2) is not picking up.	Error during manual reset S34 (stuck-at at the input).	Remove the error in the reset/start circuit. Then perform a function test.

## 18.2 Serial diagnostics via signal output M1

On corresponding signal evaluation, the safety relay transmits the following information via signal output M1.



The signal for serial diagnostics is inverted, i.e., a logical "0" is represented by 24 V and a logical "1" by 0 V.



For additional information and requirements regarding signal evaluation, please refer to the "Principle of serial diagnostics" section.

Bit	Description	Value
Bit 1	Sensor circuit S0	0: sensor circuit S0 inactive
		1: sensor circuit S0 active
Bit 2	Sensor circuit S1	0: sensor circuit S1 inactive
		1: sensor circuit S1 active
Bit 3	Output circuits K1 and K2	0: output circuits K1 and K2 inactive
		1: output circuits K1 and K2 active
Bit 4	Reset circuit	0: no start acknowledgment required
		1: start acknowledgment required
Bit 5	Safety switch 1	0: safety switch 1 open
		1: safety switch 1 closed
Bit 6	Safety switch 2	0: safety switch 2 open
		1: safety switch 2 closed
...	...	...
Bit 20	Safety switch 16	0: safety switch 16 open
		1: safety switch 16 closed

### Addressing

Refer to the figure below for the addressing of a PSR-CT safety switch chain.

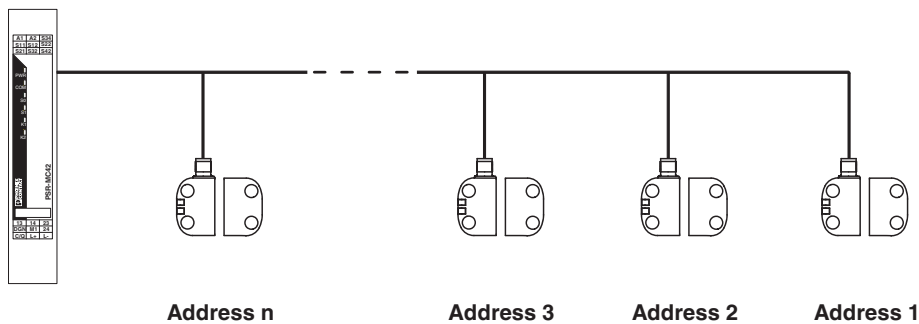

Figure 16 Addressing

## 19 IO-Link communication and diagnostic data

### 19.1 Device description file

Depending on the number of PSR-CT safety switches that are connected, you will require a corresponding device description file (IO Device Description, IODD).

The device description file can be used to configure and start up IO-Link devices. It contains information for identification, device parameters, process and diagnostic data, communication properties, and the structure of the user interface in engineering tools.

Valid device description files can be downloaded via the product page at [phoenixcontact.net/products](http://phoenixcontact.net/products).

In addition, you can download the device description file from the official IO-Link site [ioddfinder.iolink.com](http://ioddfinder.iolink.com) using the "IODDfinder".



If you have selected an incorrect IODD, the engineering tool will display a corresponding error message.

### Overview of IODDs

Vendor ID		Device ID		Input size	Output size	Number of PSR-CT
hex	dec	hex	dec			
B0	176	30110	196880	6	1	1 ... 5
B0	176	30111	196881	11	1	6 ... 10
B0	176	30112	196882	21	1	11 ... 20
B0	176	30113	196883	31	1	21 ... 30

### 19.2 Process data structure and addressing

Refer to the figure below and the corresponding table for the structure of the process data and the addressing of a PSR-CT safety switch chain.

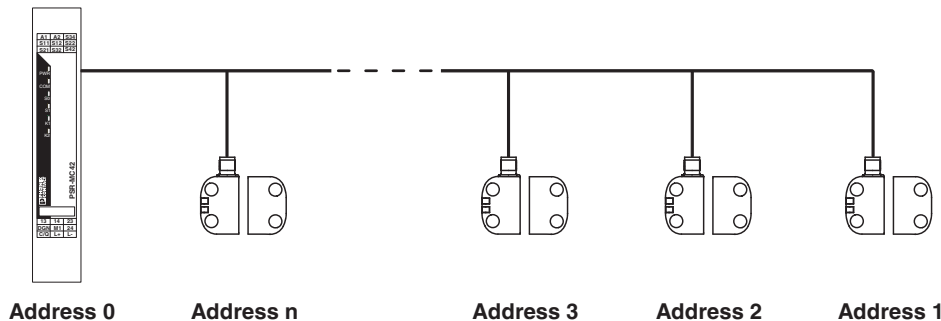

Figure 17 Addressing

Byte	0	1	2	3	...	n
Input process data	PSR-MC42	PSR-CT No. 1	PSR-CT No. 2	PSR-CT No. 3	...	PSR-CT No. n
Output process data	PSR-MC42	-	-	-	-	-

### 19.3 Cyclic data

Depending on the corresponding IO-Link, the device uses 6 / 11 / 21 / 31 input process data items.

#### 19.3.1 Input data

##### Byte 0 (IO-Link diagnostic bits/status of PSR-MC42)

Bit	Description	Value
Bit 0	Sensor circuit S0	0: sensor circuit S0 inactive
		1: sensor circuit S0 active
Bit 1	Sensor circuit S1	0: sensor circuit S1 inactive
		1: sensor circuit S1 active
Bit 2	Output circuits K1 and K2	0: output circuits K1 and K2 inactive
		1: output circuits K1 and K2 active
Bit 3	Reset circuit	0: no start acknowledgment required
		1: start acknowledgment required
Bit 4 ... bit 7	Error messages	See device status and error messages

#### Device status and error messages



If several error codes are active at the same time, the error code with the highest priority supplants the other active error codes.

Error code 0000 "Active operation" is permanently active.

Bit 4 ... bit 7	Description	Possible cause	Corrective
0111	System error	Internal error	Perform a power down reset with subsequent function test. <b>If the error occurs again after the function test, replace the device.</b>
0110	Input error	Plausibility error in the sensor circuit, cross-circuit	Check whether the second channel opens when the sensor is requested.
		Internal error	Perform a power down reset with subsequent function test. <b>If the error occurs again after the function test, replace the device.</b>
0101	IO-Link undervoltage		Check the supply voltage.
0100	PSR-MC42 undervoltage		Check the supply voltage.
0011	Communication error diagnostics	One/several safety switches cannot be accessed.	Restart the safety switch chain.
0010	Parameter error	Wrong manufacturer code for a switch. The configured fixed process data size is not sufficient.	Only use suitable PSR-CT safety switches. Remove the fixed configuration of the process data size.
0001	Diagnostics active	Internal error	Perform a power down reset with subsequent function test. <b>If the error occurs again after the function test, replace the device.</b>
0000	Active operation	-	-

**Byte 1 (IO-Link diagnostic bits/status of PSR-CT No. 1)**

Bit	Description	Value
Bit 0	Actuator detection	0: no/wrong actuator detected
		1: actuator detected
Bit 1	Limit range actuator	0: normal operation
		1: actuator within the limit range
Bit 2	Reset circuit	0: no start acknowledgment required
		1: start acknowledgment required
Bit 3	Not used	
Bit 4	Not used	
Bit 5	Input error	0: no error
		1: error
Bit 6	Output error	0: no error
		1: error
Bit 7	Internal error	0: no error
		1: error

**Byte 2 ... byte 30 (IO-Link diagnostic bits/status of PSR-CT No. 2 to PSR-CT No. 30)**

The input process data in byte 2 to byte 30 indicates the status of PSR-CT safety switch No. 2 to No. 30. The bits are used analog to byte 1 and relate to the respective switch.

**19.3.2 Output data****Byte 0 (IO-Link diagnostic bits/status of PSR-MC42)**

Bit	Description	Value
0	Enable signal	0: deactivated (enabling current paths blocked)
		1: activated (enabling current paths can be closed)
1	Chain reset	A chain reset is performed on a transition from 1 to 0
2 ... 7	Reserved	

## 19.4 Acyclic data

### 19.4.1 Write and read services

#### Index 100, subindex 0

Index dec (hex)	Subindex dec (hex)	No.	Type	Description	
100 (64)	0 (0)	1 (1)	1	UInt8	Manufacturer code safety switch 1
			2	UInt8	Input process data size safety switch 1
			3	UInt8	Output process data size safety switch 1
		2 (2)	4	UInt8	Manufacturer code safety switch 2
			5	UInt8	Input process data size safety switch 2
			6	UInt8	Output process data size safety switch 2
		...	...	UInt8	...
	30 (1E)	88	UInt8	Manufacturer code safety switch 30	
		89	UInt8	Input process data size safety switch 30	
		90	UInt8	Output process data size safety switch 30	
		31 (1F)	91	UInt8	Number of safety switches



The manufacturer code for Phoenix Contact is 0x02.

#### Index 101

Index dec (hex)	Subindex dec (hex)	No.	Type	Description	
101 (65)	0 (0)	1 (1)	1	UInt8	Manufacturer code safety switch 1
		2 (2)	2	UInt8	Manufacturer code safety switch 2
		...	...	UInt8	...
		30 (1E)	30	UInt8	Manufacturer code safety switch 30
		31 (1F)	31	UInt8	Number of safety switches

#### Index 102

Index dec (hex)	Subindex dec (hex)	No.	Type	Description	
102 (66)	0 (0)	1 (1)	1	UInt8	Input process data size safety switch 1
		2 (2)	2	UInt8	Input process data size safety switch 2
		...	...	UInt8	...
		30 (1E)	30	UInt8	Input process data size safety switch 30
		31 (1F)	31	UInt8	Number of safety switches

#### Index 103

Index dec (hex)	Subindex dec (hex)	No.	Type	Description	
103 (67)	0 (0)	1 (1)	1	UInt8	Output process data size safety switch 1
		2 (2)	2	UInt8	Output process data size safety switch 2
		...	...	UInt8	...
		30 (1E)	30	UInt8	Output process data size safety switch 30
		31 (1F)	31	UInt8	Number of safety switches

## Index 201 ... 230

Index dec (hex)	Subindex dec (hex)	No.	Type	Description
201 (C9)	0 (0)	1	UInt8	User data length of the telegram for safety switch 1
		2 ... 7	UInt8	User data of the telegram for safety switch 1
202 (CA)	0 (0)	1	UInt8	User data length of the telegram for safety switch 2
		2 ... 7	UInt8	User data of the telegram for safety switch 2
...	...	...	...	...
230 (E6)	0 (0)	1	UInt8	User data length of the telegram for safety switch 30
		2 ... 7	UInt8	User data of the telegram for safety switch 30

## 19.4.2 Write services

## Index 250

Index dec (hex)	Subindex dec (hex)	No.	Type	Description
250 (FA)	0 (0)	1	UInt8	Reset of IO-Link mode <ul style="list-style-type: none"> <li>- <b>0x01</b>: reset IO-Link mode</li> <li>- <b>0xFF</b>: maintain IO-Link mode</li> </ul>

## 19.4.3 Read services

## Index 10 ... 17

Index dec (hex)	Subindex dec (hex)	No.	Type	Description
16 (10)	0 (0)	-	String	Manufacturer
17 (11)	0 (0)	-	String	Manufacturer text
18 (12)	0 (0)	-	String	Product name
19 (13)	0 (0)	-	String	Product ID
20 (14)	0 (0)	-	String	Product text
21 (15)	0 (0)	-	String	Serial number
22 (16)	0 (0)	-	String	Hardware version
23 (17)	0 (0)	-	String	Firmware version



## 20 Application examples

### 20.1 Two-channel monitoring of emergency stop button and safety switch chain without IO-Link

**Application description:**

- Two-channel emergency stop monitoring at sensor circuit S0
- Two-channel monitoring of safety switch chain at safety switch circuit S1
- Manual, monitored start of the safety relay by reset button S2 (connection S34)
- Monitoring of external, force-guided contactors in reset circuit at S34
- Reset of safety switch S5 by reset button S6

**Notes:**



**WARNING: Loss of functional safety**  
 Make sure that the signal generator and the safety relay have the same ground potential.



Observe the information regarding applications with PSR-CT safety switches in the corresponding product documentation.

**Achievable safety integrity:**

- Suitable up to category 4, PL e (EN ISO 13849-1), SIL 3 (EN 62061)

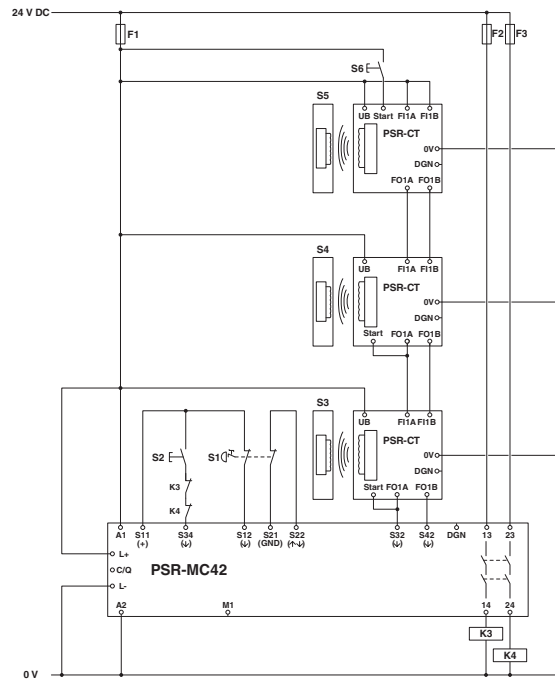

Figure 18 Monitoring of emergency stop button and safety switch chain without IO-Link

**Key:**

- S1** Emergency stop button
- S2** Manual reset device
- S3 ... S5** PSR-CT safety switch
- S6** Manual reset device
- F1 ... F3** External fuses
- K3/K4** Force-guided contactors

## 20.2 Two-channel monitoring of emergency stop button and safety switch chain with IO-Link

### Application description:

- Two-channel emergency stop monitoring at sensor circuit S0
- Two-channel monitoring of safety switch chain at safety switch circuit S1
- Manual, monitored start of the safety relay by reset button S2 (connection S34)
- Monitoring of external, force-guided contactors in reset circuit at S34
- Reset of safety switch S5 by reset button S6
- IO-Link connection between the safety relay and an IO-Link master

### Notes:



**WARNING: Loss of functional safety**  
Make sure that the signal generator and the safety relay have the same ground potential.



Observe the information regarding applications with PSR-CT safety switches in the corresponding product documentation.

### Achievable safety integrity:

- Suitable up to category 4, PL e (EN ISO 13849-1), SIL 3 (EN 62061)

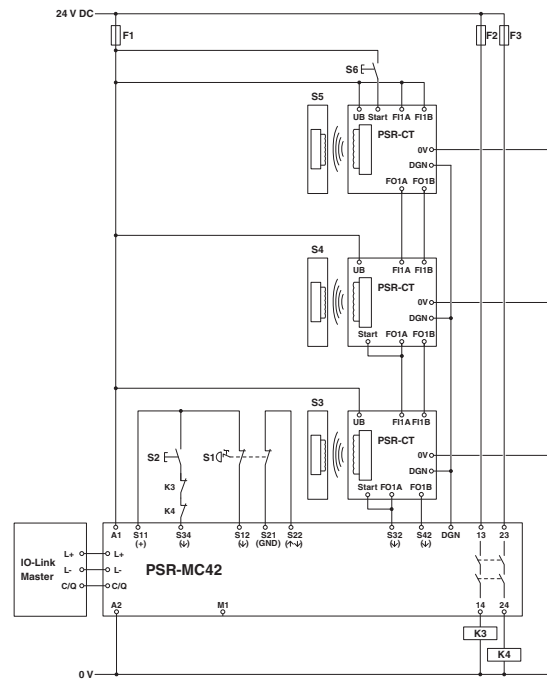

Figure 19 Monitoring of emergency stop button and safety switch chain with IO-Link

### Key:

- S1** Emergency stop button
- S2** Manual reset device
- S3 ... S5** PSR-CT safety switch
- S6** Manual reset device
- F1 ... F3** External fuses
- K3/K4** Force-guided contactors

## 21 Attachment

### 21.1 Using PSR devices at altitudes greater than 2000 m above sea level



The following section describes the special conditions for using PSR devices at altitudes greater than 2000 m above sea level. Observe the relevant device-specific data (technical data, derating, etc.) according to the product documentation for the individual device.

Using the device at altitudes **greater than 2000 m above sea level up to max. 4500 m above sea level** is possible under the following conditions:

1. Limit the rated control circuit supply voltage ( $U_S$ ) in accordance with the table below. Observe the technical data for the device.

$U_S$ according to the technical data for the device	$U_S$ when used at altitudes greater than 2000 m above sea level
< 150 V AC/DC	$U_S$ according to the technical data for the device still valid
> 150 V AC/DC	Limited to max. 150 V AC/DC

2. Limit the maximum switching voltage in accordance with the table below. Observe the technical data for the device.

Max. switching voltage according to the technical data for the device	Max. switching voltage when used at altitudes greater than 2000 m above sea level
< 150 V AC/DC	Max. switching voltage according to the technical data for the device still valid
> 150 V AC/DC	Limited to max. 150 V AC/DC

3. Reduce the maximum ambient temperature for operation by the corresponding factor in accordance with the table below.
4. If derating is specified, offset all the points of the derating curve by the corresponding factor in accordance with the table below.

Altitude above sea level	Temperature derating factor
2000 m	1
2500 m	0.953
3000 m	0.906
3500 m	0.859
4000 m	0.813
4500 m	0.766

#### Example calculation for 3000 m



The following calculation and the illustrated derating curve are provided as examples. Perform the actual calculation and offset the derating curve for the device used according to the technical data and the "Derating" section.

$$27\text{ °C} \cdot 0.906 \approx 24\text{ °C}$$

$$55\text{ °C} \cdot 0.906 \approx 49\text{ °C}$$

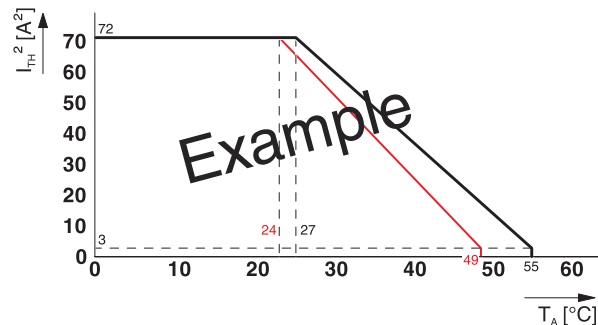

Figure 20 Example of a suspended derating curve (red)

---

## 21.2 Revision history

Version	Date	Contents
00	2018-11-22	First publication