



Hex Inverter, 4-Bit and 2-Bit, 3-State

ELECTRICALLY TESTED PER:
MIL-M-38510/32204

This device is a high-speed hex buffer with 3-state outputs. It is organized as a single 6-bit or 2-bit/4-bit, with inverting or non-inverting data (D) paths. The outputs are designed to drive 15 TTL Unit Loads or 60 Low Power Schottky loads when the Enable (E) is LOW.

When the Output Enable (E) is HIGH, the outputs are forced to a high impedance "off" state. If the outputs of the 3-state devices are tied together, all but one device must be in the high impedance state to avoid high currents that would exceed the maximum ratings. Designers should ensure that Output Enable signals to 3-state devices whose outputs are tied together are designed so there is no overlap.

LOGIC DIAGRAM

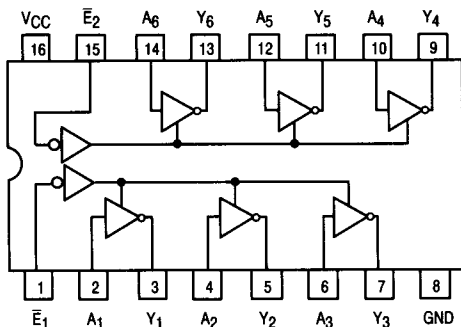

AC TEST CIRCUIT

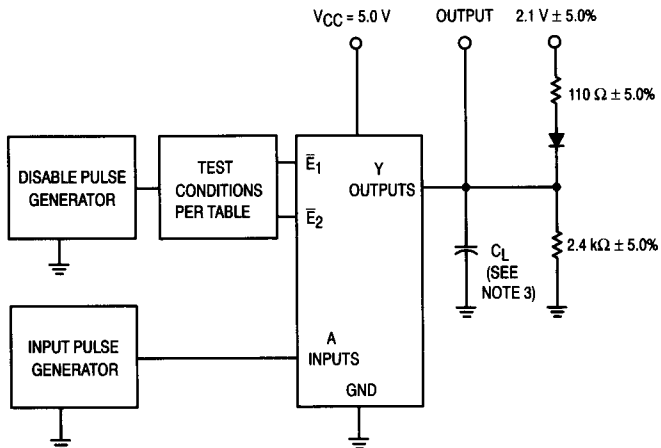

REFERENCE NOTES ON PAGE 5-376

Military 54LS368A



AVAILABLE AS:

- 1) JAN: JM38510/32204BXA
- 2) SMD: N/A
- 3) 883: 54LS368A/BXAJC

X = CASE OUTLINE AS FOLLOWS:
PACKAGE: CERDIP: E
CERFLAT: F
LCC: 2

THE LETTER "M" APPEARS BEFORE THE / ON LCC.

PIN ASSIGNMENTS

FUNCT.	DIL 620-09	FLATS 650-05	LCC 756A-02	BURN-IN (COND. A)
\bar{E}_1	1	1	2	GND
A ₁	2	2	3	GND
Y ₁	3	3	4	VCC
A ₂	4	4	5	GND
Y ₂	5	5	7	VCC
A ₃	6	6	8	GND
Y ₃	7	7	9	VCC
GND	8	8	10	GND
Y ₄	9	9	12	VCC
A ₄	10	10	13	GND
Y ₅	11	11	14	VCC
A ₅	12	12	15	GND
Y ₆	13	13	17	VCC
A ₆	14	14	18	GND
\bar{E}_2	15	15	19	GND
VCC	16	16	20	VCC

BURN-IN CONDITIONS:
VCC = 5.0 V MIN/6.0 V MAX

TRUTH TABLE

Inputs		Output
\bar{E}	D	
L	L	H
L	H	L
H	X	(Z)

54LS368A

VOLTAGE WAVEFORMS PROPAGATION DELAY TIMES

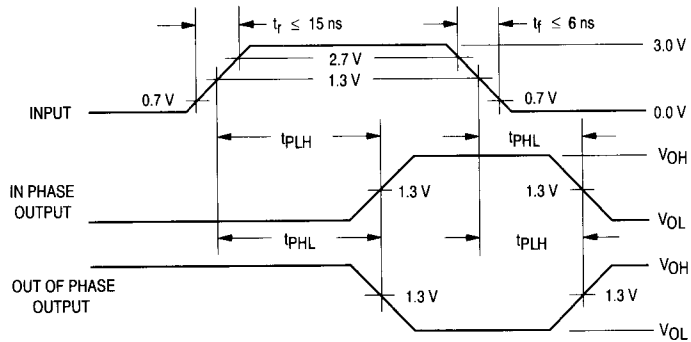

VOLTAGE WAVEFORMS ENABLE AND DISABLE TIMES, THREE-STATE OUTPUTS

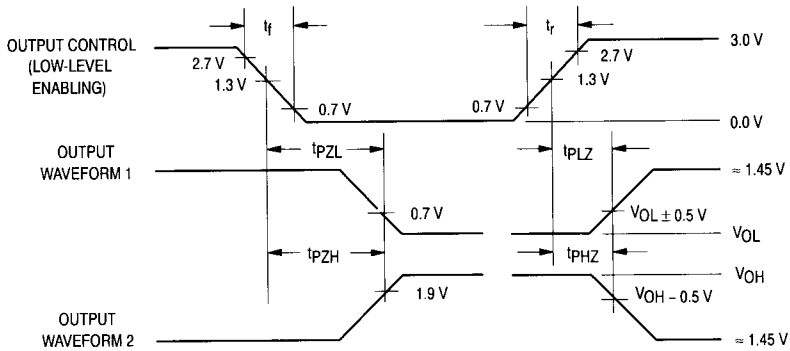

NOTES:

1. Pulse generator has the following characteristics:
 $t_r \leq 15 \text{ ns}$, $t_f \leq 6.0 \text{ ns}$.
2. Terminal conditions (pins not designated may be high $\geq 2.0 \text{ V}$, low $\leq 0.7 \text{ V}$, or open).
3. $C_L = 50 \text{ pF} \pm 10\%$, including scope probe, wiring and stray capacitance.
4. Voltage measurements are to be made with respect to network ground terminal.

54LS368A

Symbol	Parameter	Limits						Unit	Test Condition (Unless Otherwise Specified)
		+ 25°C		+ 125°C		- 55°C			
		Subgroup 1		Subgroup 2		Subgroup 3			
		Min	Max	Min	Max	Min	Max		
V _{OH}	Logical "1" Output Voltage	2.4		2.4		2.4		V	V _{CC} = 4.5 V, I _{OH} = - 1.0 mA, V _{IL} = 0.7 V, \bar{E}_n = 0.7 V, other inputs are open.
V _{OL}	Logical "0" Output Voltage		0.4		0.4		0.4	V	V _{CC} = 4.5 V, I _{OL} = 12 mA, V _{IH} = 2.0 V, \bar{E}_n = 0.7 V, other inputs are open.
V _{IC}	Input Clamping Voltage		- 1.5					V	V _{CC} = 4.5 V, I _{IN} = - 18 mA, other inputs are open.
I _{IH}	Logical "1" Input Current		20		20		20	μA	V _{CC} = 5.5 V, V _{IH} = 2.7 V, other inputs are open.
I _{IHH}	Logical "1" Input Current		100		100		100	μA	V _{CC} = 5.5 V, V _{IHH} = 5.5 V, other inputs are open.
I _{IL}	Logical "0" Input Current	- 160	- 400	- 160	- 400	- 160	- 400	μA	V _{CC} = 5.5 V, V _{IN} = 0.4 V, \bar{E}_n = 0.4 V or open, other inputs are open.
I _{IL} (\bar{E}_n)	Logical "0" Input Current	- 160	- 400	- 160	- 400	- 160	- 400	μA	V _{CC} = 5.5 V, V _{IN} = 0.4 V (\bar{E}_n), other inputs are open.
I _{OS}	Output Short Circuit Current	- 30	- 130	- 30	- 130	- 30	- 130	mA	V _{CC} = 5.5 V, V _{IN} = GND, V _{OUT} = GND, \bar{E}_n = 0.7 V or open, other inputs are open.
I _{OZH}	Output Off Current High		20		20		20	μA	V _{CC} = 5.5 V, V _{IH} = 2.0 V, \bar{E}_n = 2.0 V or open, V _{IL} = 0.7 V, V _{OUT} = 2.4 V, other inputs are open.
I _{OZL}	Output Off Current Low		- 20		- 20		- 20	μA	V _{CC} = 5.5 V, V _{IL} = 0.7 V, \bar{E}_n = 2.0 V or open, V _{IH} = 2.0 V, V _{OUT} = 0.4 V, other inputs are open.
I _{CC}	Power Supply Current		21		21		21	mA	V _{CC} = 5.5 V, V _{IN} = GND, \bar{E}_n = 4.5 V.
V _{IH}	Logical "1" Input Voltage	2.0		2.0		2.0		V	V _{CC} = 4.5 V.
V _{IL}	Logical "0" Input Voltage		0.7		0.7		0.7	V	V _{CC} = 4.5 V.
	Functional Tests	Subgroup 7		Subgroup 8A		Subgroup 8B			per Truth Table with V _{CC} = 5.0 V, V _{INL} = 0.4 V, and V _{INH} = 2.4 V.

54LS368A

Symbol	Parameter	Limits						Unit	Test Condition (Unless Otherwise Specified)
		+ 25°C		+ 125°C		- 55°C			
		Subgroup 9		Subgroup 10		Subgroup 11			
		Min	Max	Min	Max	Min	Max		
t _{PHL} t _{PHL}	Propagation Delay /Data-Output Output <u>High-Low</u>	2.0 —	18 18	2.0 —	23 23	2.0 —	23 23	ns	V _{CC} = 5.0 V, C _L = 50 pF, R _L = 110 Ω ± 5.0%. V _{CC} = 5.0 V, C _L = 45 pF, R _L = 667 Ω.
t _{PLH} t _{PLH}	Propagation Delay /Data-Output Output <u>Low-High</u>	2.0 —	15 15	2.0 —	20 19	2.0 —	20 19	ns	V _{CC} = 5.0 V, C _L = 50 pF, R _L = 110 Ω ± 5.0%. V _{CC} = 5.0 V, C _L = 45 pF, R _L = 667 Ω.
t _{PZH} t _{PZH}	Propagation Delay /Data-Output Output <u>High-Low</u>	2.0 —	35 35	2.0 —	45 44	2.0 —	45 44	ns	V _{CC} = 5.0 V, C _L = 50 pF, R _L = 110 Ω ± 5.0%. V _{CC} = 5.0 V, C _L = 45 pF, R _L = 667 Ω.
t _{PZL} t _{PZL}	Propagation Delay /Data-Output Output <u>Low-High</u>	2.0 —	45 45	2.0 —	58 56	2.0 —	58 56	ns	V _{CC} = 5.0 V, C _L = 50 pF, R _L = 110 Ω ± 5.0%. V _{CC} = 5.0 V, C _L = 45 pF, R _L = 667 Ω.
t _{PHZ} t _{PHZ}	Propagation Delay /Data-Output Output <u>High-Low</u>	2.0 —	32 32	2.0 —	42 40	2.0 —	42 40	ns	V _{CC} = 5.0 V, C _L = 50 pF, R _L = 110 Ω ± 5.0%. V _{CC} = 5.0 V, C _L = 5.0 pF, R _L = 667 Ω.
t _{PLZ} t _{PLZ}	Propagation Delay /Data-Output Output <u>Low-High</u>	2.0 —	35 35	2.0 —	45 44	2.0 —	45 44	ns	V _{CC} = 5.0 V, C _L = 50 pF, R _L = 110 Ω ± 5.0%. V _{CC} = 5.0 V, C _L = 5.0 pF, R _L = 667 Ω.

NOTE:

1. The limits specified for C_L = 45 pF and C_L = 5.0 pF are guaranteed but not tested.