

**PROPRIETARY INFORMATION:**  
 PROPRIETARY OF GLOBTEK, INC. ANY REPRODUCTION, DISCLOSURE OR USE OF THIS DRAWING, IN WHOLE OR IN PART, IS HEREBY PROHIBITED EXCEPT AS SPECIFIED IN WRITING BY GLOBTEK, INC.

REVISION			
REV	DESCRIPTION	DATE	APPROVED
A	INITIAL RELEASE, RFS. 9042, BS	08/02/06	BS

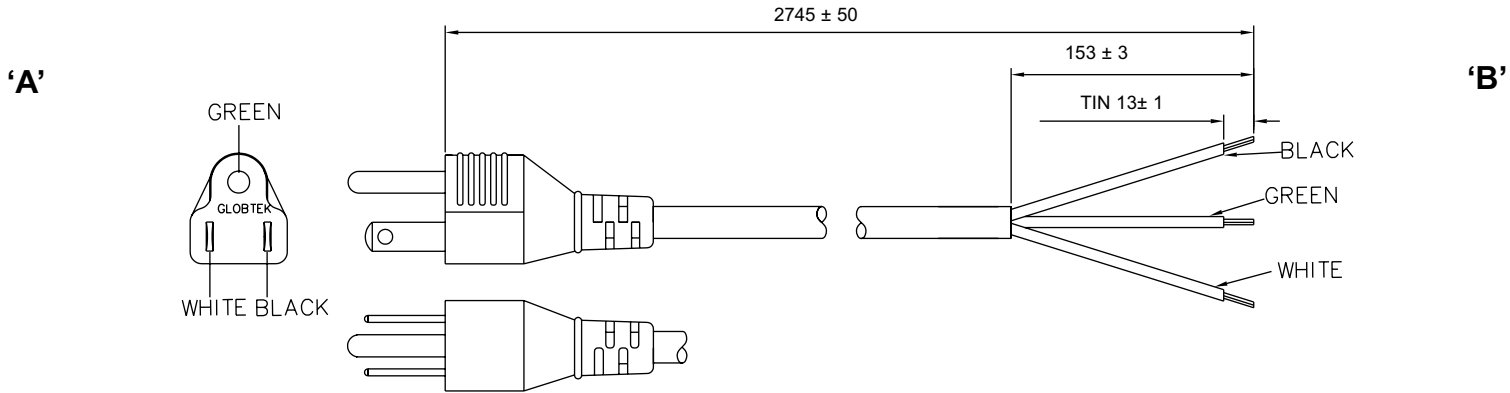

**GENERAL SPECIFICATIONS:**

RATING: 10A / 125V AC  
 CABLE TYPE / SIZE: SJT, # 18 AWG, 3 CONDUCTOR  
 TEMPERATURE RATING: 60° C MIN.  
 CONDUCTOR COLORS: BLACK / WHITE / GREEN  
 CABLE JACKET COLOR: PEA GREEN, PANTONE 617U  
 OVERALL LENGTH (L): 2745 ± 50 mm  
 CABLE OUTER DIAMETER: 7.8 ± 0.1 mm  
 END 'A' PLUG; NEMA 5-15P  
 END 'B' SEE TERMINATION TABLE  
 APPROVALS PLUG: UL, CSA or cUL  
 APPROVALS CABLE: UL, CSA or cUL

**NOTES:**

1. CORD AND PLUG MUST BE MARKED WITH APPROVAL SYMBOLS AND/ OR FILE NUMBERS.



**CONDUCTOR TERMINATION TABLE:**

Wire	Color	ROJ ± 3 mm	STRIP ± 1mm	TERMINATION
NEUTRAL	WHITE	153	13	STRIPPED & TINNED
LINE	BLACK	153	13	STRIPPED & TINNED
GROUND	GREEN	153	13	STRIPPED & TINNED

**PACKING:**

BULK PACK, BUNDLES OF 25



DASH NO.	PART NO	REV.	DESCRIPTION	NOTES
<b>TABULATION BLOCK</b>				
		<b>TOLERANCES:</b> DECIMALS ANGULAR .xx +/- 0.1 +/- 1° .xxx +/- .005		<b>GlobTek, Inc.</b> 186 Veterans Dr. Northvale, NJ 07647 www.globtek.com Tel. 201-784-1000 Fax 201.784.0111
		MILLIMETERS ANGULAR .xx +/- 0.3 +/- 1° .xxx +/- .013		
INIT.BY: BS	DATE: 08/02/06	<b>DWG TITLE: NORTH AMERICAN NON-DETACHABLE CORDSET</b>		REV. A  PART NO: <b>3021069F0GN(R)</b>  SHEET 1/1
DRAWN: NF	DATE: 08/02/06	FSCN No.: G, CC	SIZE A	
APRVD: HM	DATE: 08/02/06	SCALE: NONE		

Foot Note:  
 Globtek Inc. will not be liable for the safety and performance of these power supplies if unauthorized access and repair occurs. End user should consult the applicable UL, CSA or EN Standards for proper installation instruction.

Limitation of Use:  
 Globtek product are not authorized for use as mission critical components in life support, hazardous environment, nuclear or aircraft applications without prior written approval from the CEO of Globtek Inc.

Contents of this document are subject to change without prior notice