

INSTALLATION INSTRUCTIONS FOR THE **SMART POSITION SENSOR,** **35 MM, 75 MM, 225 MM LINEAR CONFIGURATIONS**

50046793

Issue 5

GENERAL INFORMATION





Why is the SMART Position Sensor smart? SMART means that this is a sensor that can essentially think for itself. The SMART Position Sensor has the ability to self-calibrate because it uses a patented combination of an ASIC (Application-Specific Integrated Circuit) and an array of MR (magneto-resistive) sensors to accurately and reliably determine the position of a magnet attached to a moving object (e.g., elevator, valve, machinery, etc.) so that the object's position can be determined.

The MR array measures the output of the MR sensors mounted along the magnet's direction of travel. The output and the MR sensor sequence determine the nearest pair of MR sensors to the center of the magnet location. The output of these two MR sensors is then used to determine the position of the magnet between them. With this sensor, Honeywell has utilized MR technology through the ASIC at a level never before accomplished.

MOUNTING AND WIRING INFORMATION (see Fig. 2)

1. Locate sensor and magnet in desired position. Ensure:
 - Air gap between sensor and magnet does not exceed that given in Table 1.
 - Alignment of magnet along length of sensor does not exceed $2,0 \pm 2,5$ mm [0.078 ± 0.098 in] from the center line of each component.
2. Mount sensor:
 - Drill two holes, one for each mounting ear.
 - Secure sensor using two 1/4-20 or M6 screws through each mounting ear.
 - Torque screws to 6 N m to 10 N m [53.1 in lb to 88.5 in lb].
3. Mount magnet (Does not apply to 35 mm version.):
 - Drill two holes:
 - One for the single mounting ear.
 - One at $10,25 \pm 0.10$ mm [0.403 ± 0.004] dia., and at least 3 mm [0.118 in] deep, for the mounting dog (helps stabilize magnet).
 - While ensuring the mounting dog is seated in its hole, secure magnet using one 1/4-20 or M6 screw through the mounting ear.
 - Torque screws to 6 N m to 10 N m [53.1 in lb to 88.5 in lb].
4. Wire sensor according to the lead colors given in Table 1. (Does not apply to 35 mm version.)

TABLE 1. SPECIFICATIONS

CHARACTERISTIC	COMPONENT	PARAMETER			
		35 mm	75 mm	225 mm	
		SPS-L035-LATS (analog) 	SPS-L075-HALS (analog) 	SPS-L225-HALS (analog) 	SPS-L225-HDLS (digital) 
Sensing range	sensor only	0 mm to 35 mm [0 in to 1.38 in]	0 mm to 75 mm [0 in to 2.95 in]	0 mm to 225 mm [0 in to 8.86 in]	
Resolution		0,04 mm [0.0016 in]	0,05 mm [0.002 in]	0,14 mm [0.0055 in]	0,0035 mm [0.000137 in]
Supply voltage		4.75 Vdc to 5.25 Vdc	6 Vdc to 24 Vdc		
Output		0.55 Vdc to 4.15 Vdc	0 Vdc to 5 Vdc		RS 232-type digital
Supply current		20 mA max.	32 mA max.	34 mA max.	88 mA max.
Linearity ¹		±1.0% full scale output	±0.4% full scale output		
Reverse polarity		-5 V	26.4 V at 125°C [257°F]		
Sensitivity		103 mV/mm typ.	50 mV/mm typ.	17.78 mV/mm typ.	282.16 counts/mm typ.
Update rate		476 µs	400 µs		3200 µs
Baud rate			-		57.6 kbits/s
Initial startup time		5 ms	30 ms		
Termination		TYCO Super Seal 282087-1 integral connector	flying leads		
Cable bend radius		-	40 mm [1.6 in] min.		
Operating temperature			-40°C to 125°C [-40°F to 257°F]		
Storage temperature		-40°C to 150°C [-40°F to 302°F]			
Air gap		8,5 ±1,0 mm [0.334 ±0.039 in]	3,0 ±2,5 mm [0.118 ±0.098 in]		
Sealing		IP67, IP69K			
Radiated immunity	sensor and magnet actuator	100 V/m per ISO 11452-2	-		
Conducted immunity		100 mA BCI per ISO 11452-4	-		
Shock		50 G half sine wave with 11 ms duration			
Vibration		20 G from 10 Hz to 2000 Hz	10 G from 10 Hz to 2000 Hz		
Housing material		thermoplastic			
Approvals		CE, UKCA			
Mounting: screws recommended torque		¼-20 or M6 6 N m to 10 N m [53.1 in-lb to 88.5 in-lb]			
Material	magnet	neodymium iron boron			
Strength	actuator only	13,500 Gauss	10,000 Gauss		

¹ Percent linearity is the quotient of the measured output deviation from the best fit line at the measured temperature to the full scale output span.

NOTICE

- Ferrous metal within a 100 mm [3.9 in] radius of the magnet actuator may affect sensor performance.
- Always use fresh, non-magnetic stainless steel washers when mounting the sensor.

SMART POSITION SENSOR, 35 MM, 75 MM, 225 MM LINEAR CONFIGURATIONS

Issue 5
50046793

FIGURE 1. SPS-L035-LATS MOUNTING DIMENSIONS (FOR REFERENCE ONLY: MM)
AND SENSOR OUTPUT PERFORMANCE GRAPH

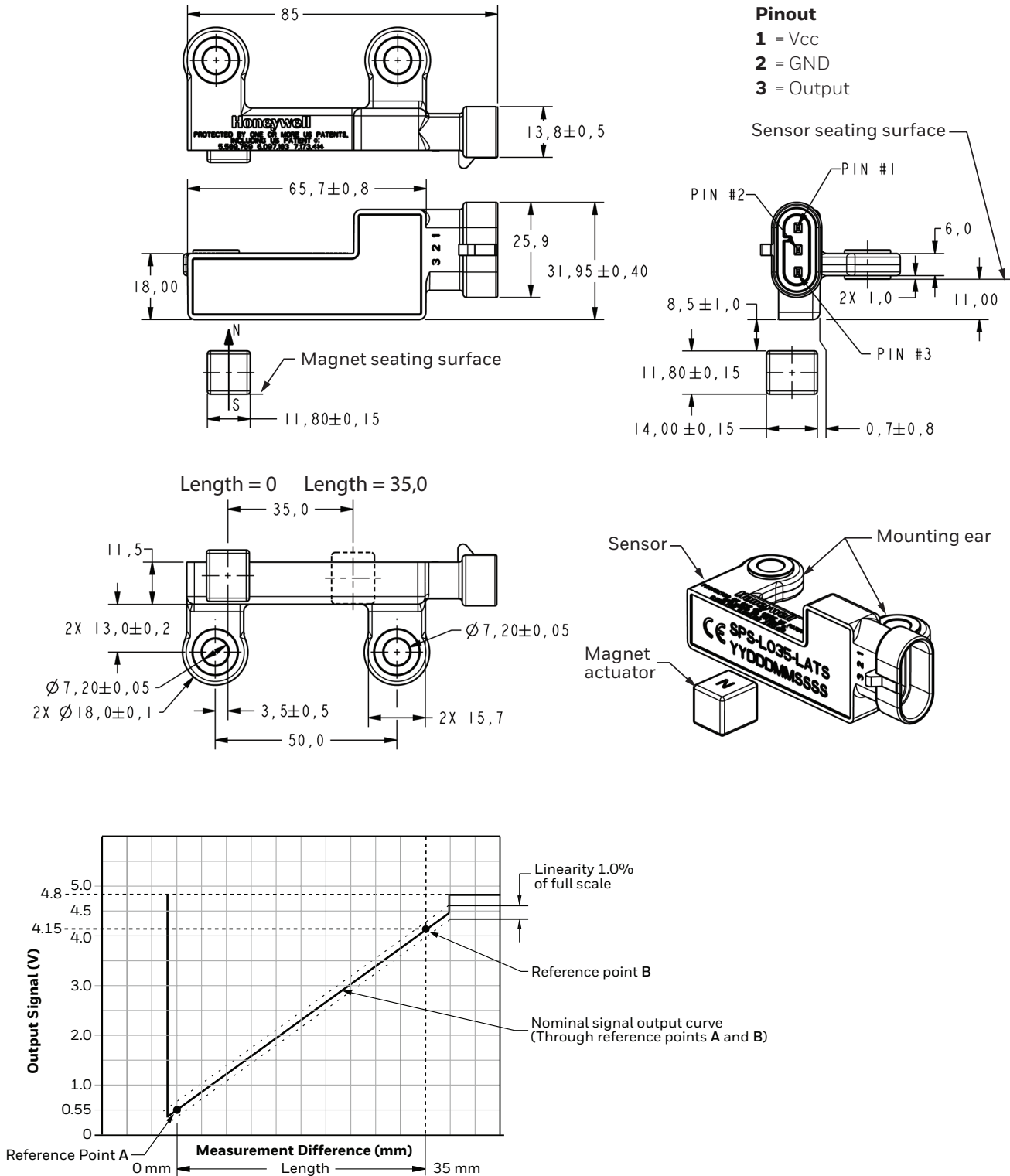

SMART POSITION SENSOR, 35 MM, 75 MM, 225 MM LINEAR CONFIGURATIONS

Issue 5
50046793

FIGURE 2. SPS-L075-HALS MOUNTING DIMENSIONS (FOR REFERENCE ONLY: MM)
AND SENSOR OUTPUT PERFORMANCE GRAPH

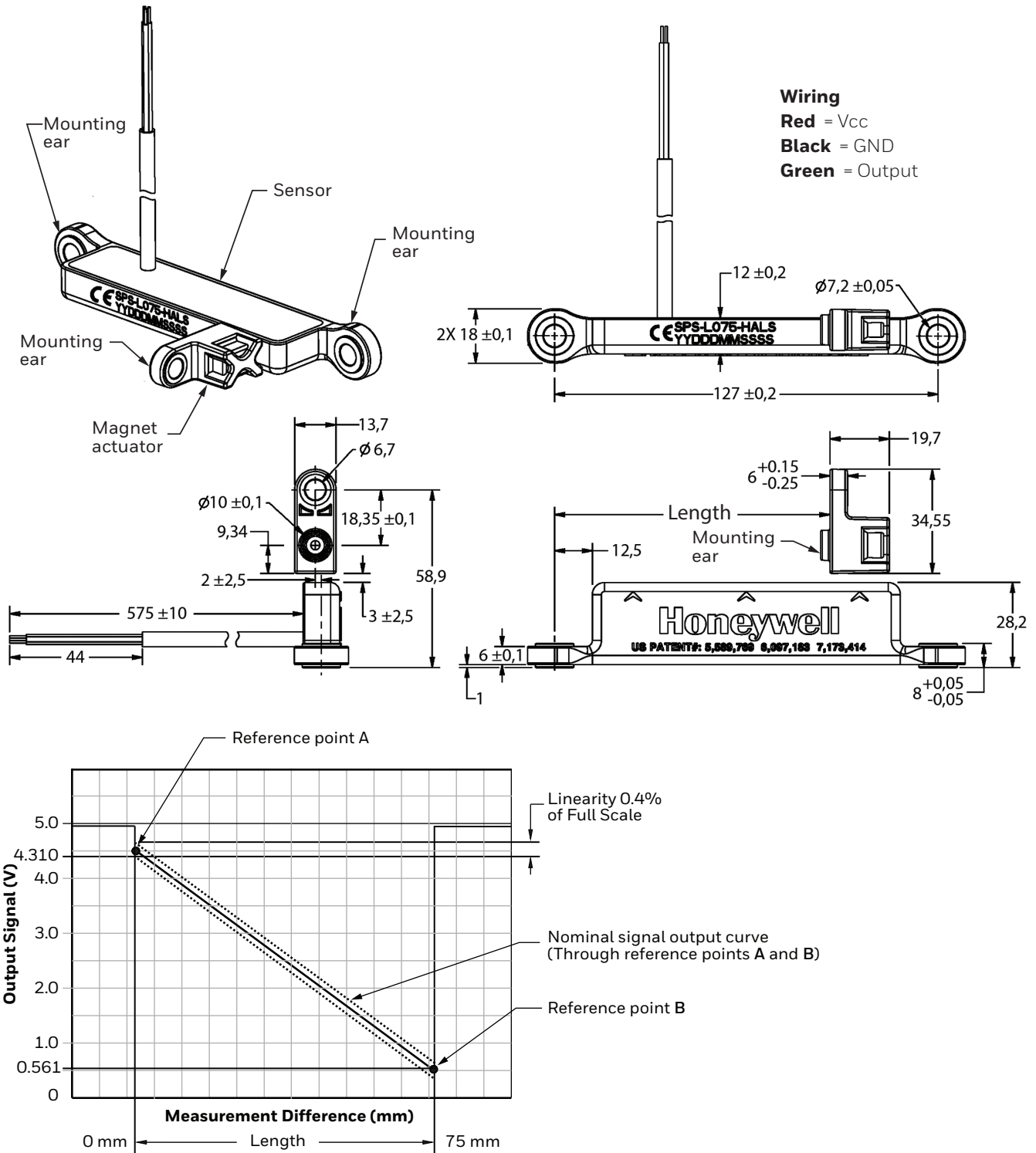

SMART POSITION SENSOR, 35 MM, 75 MM, 225 MM LINEAR CONFIGURATIONS

Issue 5
50046793

FIGURE 3. SPS-L225-HALS MOUNTING DIMENSIONS (FOR REFERENCE ONLY: MM)
AND SENSOR OUTPUT PERFORMANCE GRAPH

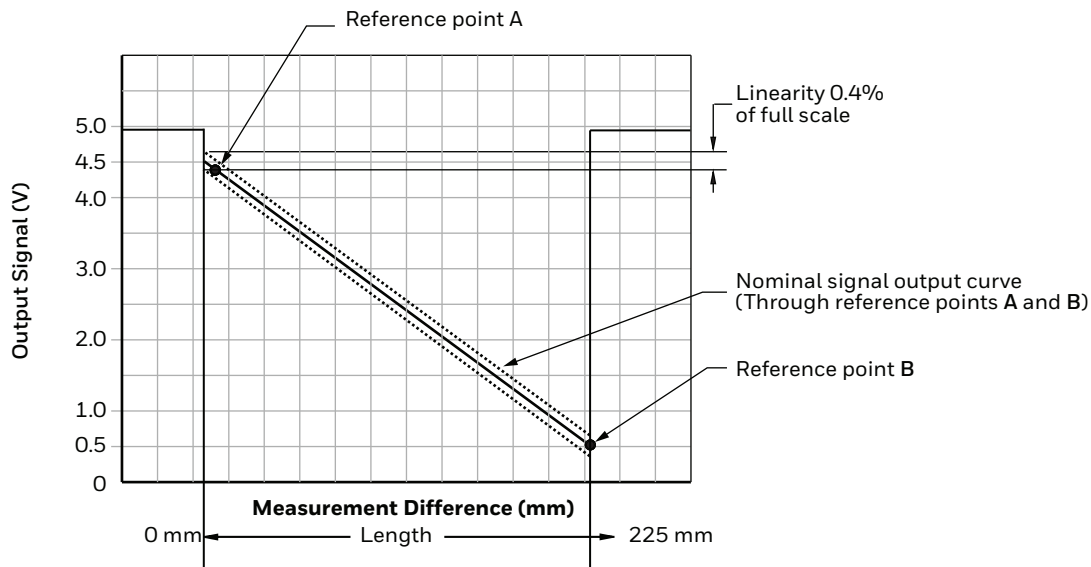
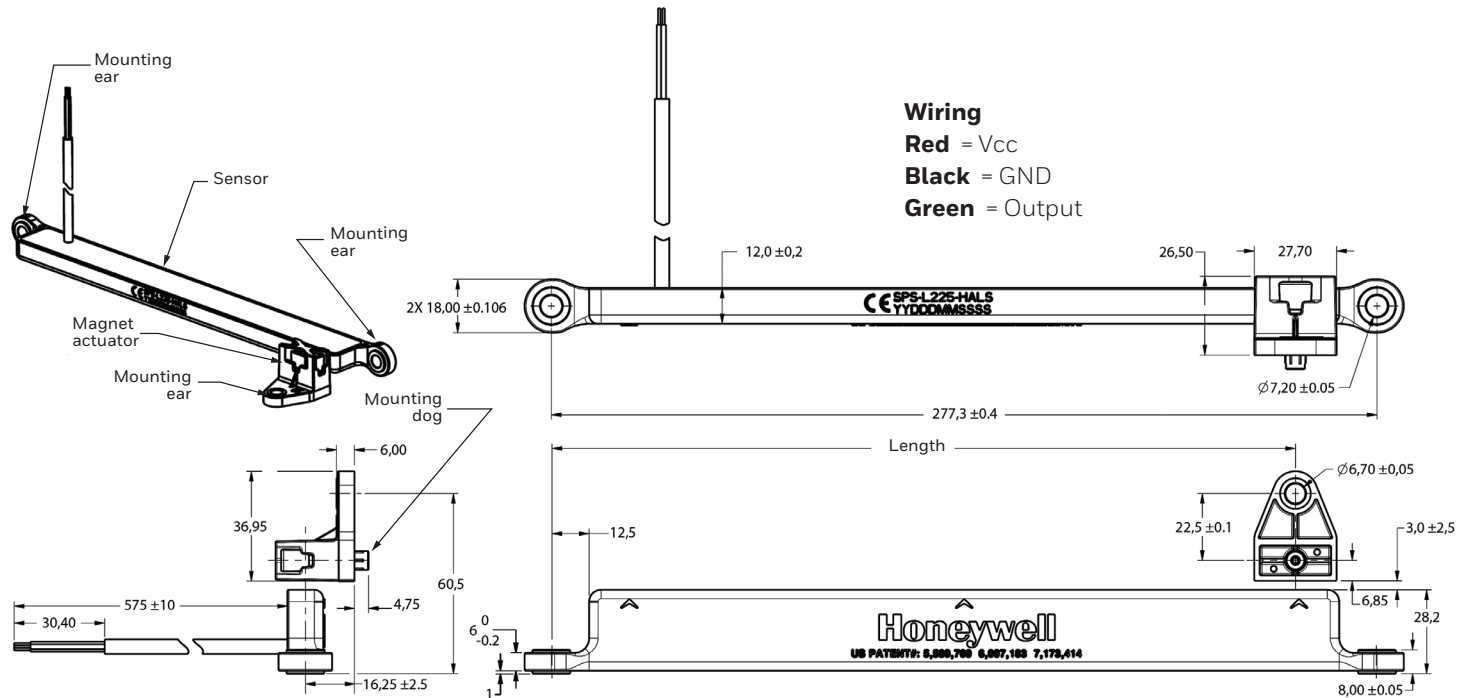

SMART POSITION SENSOR, 35 MM, 75 MM, 225 MM LINEAR CONFIGURATIONS

Issue 5
50046793

FIGURE 4. SPS-L225-HDLS MOUNTING DIMENSIONS (FOR REFERENCE ONLY: MM) AND SENSOR OUTPUT PERFORMANCE GRAPH

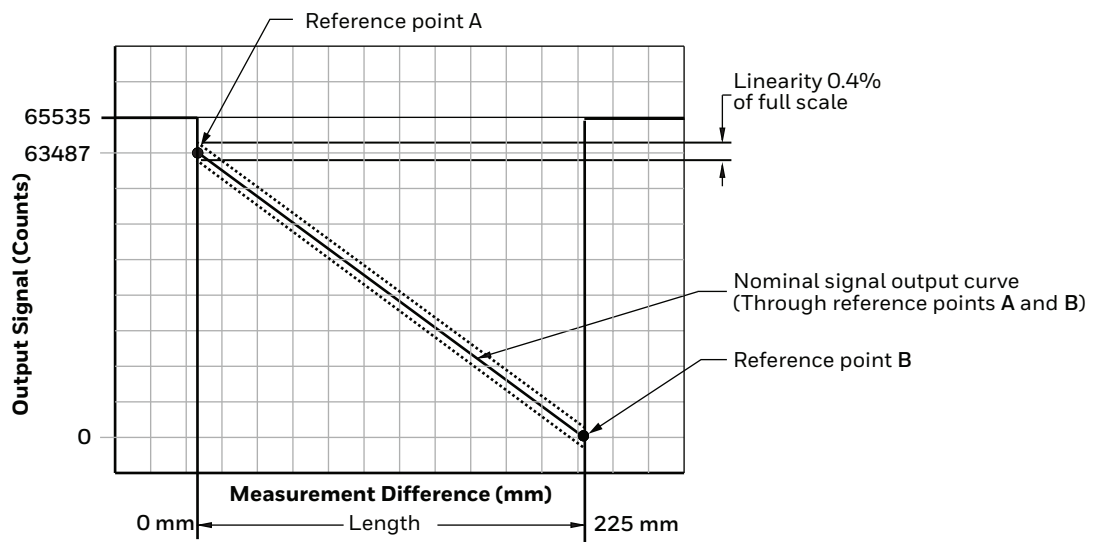
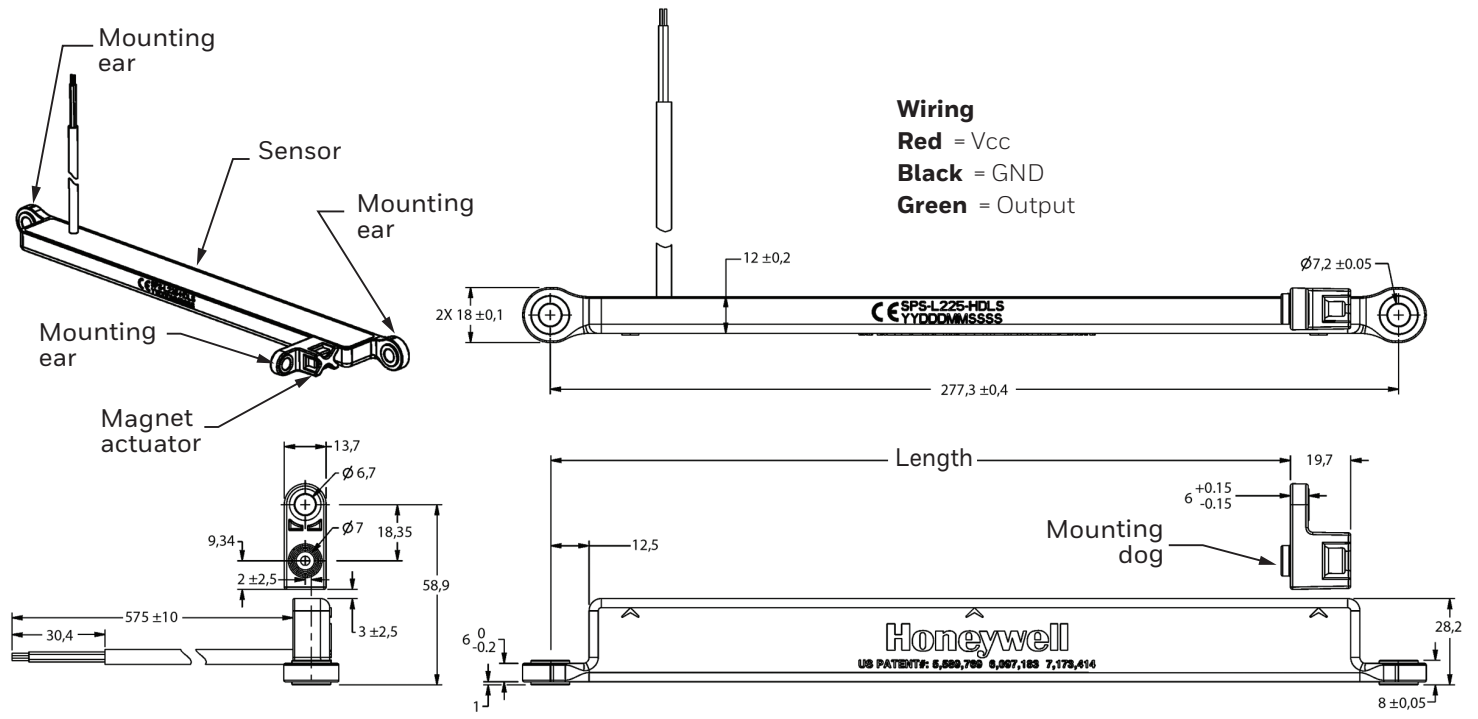

⚠️ WARNING **PERSONAL INJURY**

DO NOT USE these products as safety or emergency stop devices or in any other application where failure of the product could result in personal injury.

Failure to comply with these instructions could result in death or serious injury.

⚠️ WARNING **MISUSE OF** **DOCUMENTATION**

- The information presented in this product sheet is for reference only. Do not use this document as a product installation guide.
- Complete installation, operation, and maintenance information is provided in the instructions supplied with each product.

Failure to comply with these instructions could result in death or serious injury.

FOR MORE INFORMATION

Honeywell Advanced Sensing Technologies services its customers through a worldwide network of sales offices and distributors. For application assistance, current specifications, pricing or the nearest Authorized Distributor, visit [our website](#) or call:

USA/Canada	+1 302 613 4491
Latin America	+1 305 805 8188
Europe	+44 1344 238258
Japan	+81 (0) 3-6730-7152
Singapore	+65 6355 2828
Greater China	+86 4006396841

Honeywell
Advanced Sensing Technologies
830 East Arapaho Road
Richardson, TX 75081
sps.honeywell.com/ast

WARRANTY/REMEDY

Honeywell warrants goods of its manufacture as being free of defective materials and faulty workmanship during the applicable warranty period. Honeywell's standard product warranty applies unless agreed to otherwise by Honeywell in writing; please refer to your order acknowledgment or consult your local sales office for specific warranty details. If warranted goods are returned to Honeywell during the period of coverage, Honeywell will repair or replace, at its option, without charge those items that Honeywell, in its sole discretion, finds defective. **The foregoing is buyer's sole remedy and is in lieu of all other warranties, expressed or implied, including those of merchantability and fitness for a particular purpose. In no event shall Honeywell be liable for consequential, special, or indirect damages.**

While Honeywell may provide application assistance personally, through our literature and the Honeywell web site, it is buyer's sole responsibility to determine the suitability of the product in the application.

Specifications may change without notice. The information we supply is believed to be accurate and reliable as of this writing. However, Honeywell assumes no responsibility for its use.