

CA3000/...

High-Reliability
DC Amplifier

The CA3000 Slash (/) Series type is supplied in the 10-lead TO-5 style package.

TABLE A. POST BURN-IN, FINAL ELECTRICAL AND GROUP A SAMPLING TESTS

Characteristics	Symbol	Test Conditions $V^+ = +6\text{ V}$, $V^- = -6\text{ V}$	Limits for Indicated Temp.(°C)						Units	
			Minimum			Maximum				
			-55	+25	+125	-55	+25	+125		
STATIC										
Input Offset Voltage	V_{IO}	—	—	—	—	6.5	5	6.5	mV	
Input Offset Current	I_{IO}	—	—	—	—	20	10	20	μA	
Input Bias Current	I_I	—	—	—	—	70	36	25	μA	
Quiescent Operating Voltage	V_8 or V_{10}	Terminal 4	Terminal 5							
		NC	NC	—	1.5	—	—	3.2	—	V
Device Dissipation	P_T	Terminal 4	Terminal 5							
		NC	NC	30	25	20	60	60	50	mW
		NC	-V _{EE}	25	20	15	55	55	50	mW
		-V _{EE}	NC	55	50	45	105	105	90	mW
		-V _{EE}	-V _{EE}	35	35	25	70	70	65	mW
DYNAMIC										
Differential Voltage Gain	A_{Diff}		Single-Ended Output	—	28	—	—	—	dB	
Maximum Output Voltage	$V_{OUT(p-p)}$			—	5	—	—	—	V_{p-p}	
Bandwidth at -3 dB Point	BW			—	600	—	—	—	kHz	
Common-Mode Rejection Ratio	CMR			—	70	—	—	—	dB	
AGC Range (Maximum Voltage Gain to Complete Cut-off)	AGC			—	80	—	—	—	dB	

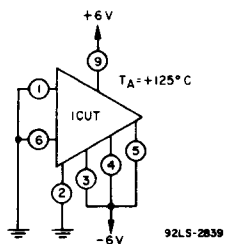

Burn-in and operating life test circuit

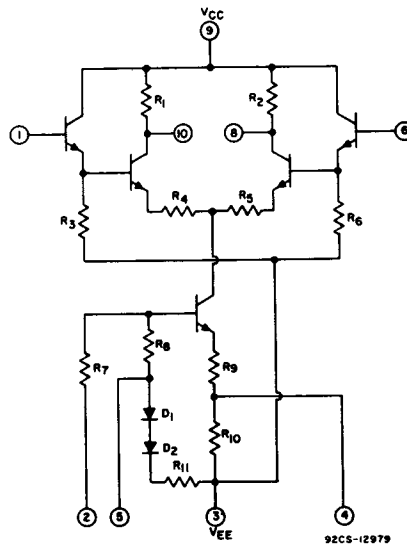

Schematic Diagram

TABLE B. DELTA LIMITS at $T_A = 25^\circ C$, $V^+ = +6 V$, $V^- = -6 V$ (/1 only)

CHARACTERISTIC	SYMBOL	TEST CONDITIONS	LIMITS	UNITS
			MAX. Δ	
Input Bias Current	I_I	—	± 4	μA
Quiescent Operating Voltage	V_8 or V_{10}	Terminal 4: NC Terminal 5: NC	± 0.3	V
Device Dissipation	P_T	Terminal 4: NC Terminal 5: NC	± 6	mW
Input Offset Current	I_{IO}	—	± 2	μA
Input Offset Voltage	V_{IO}	—	± 1	mV

TABLE C. GROUPS C AND D END-POINT TESTS at $T_A = 25^\circ C$

Characteristic	Symbol	TEST CONDITIONS $V^+ = +6 V$, $V^- = -6 V$	Limits		Units
			Min.	Max.	
Input Offset Voltage	V_{IO}		—	5	mV
Input Offset Current	i_{IO}		—	10	μA
Input Bias Current	I_I		—	36	μA
Quiescent Operating Voltage	V_8 or V_{10}		1.5	3.2	V
Device Dissipation	P_T	Terminal 4 NC Terminal 5 NC	25	60	mW
Differential Voltage Gain Single-Ended Input	A_{DIFF}	Single Ended Output $f = 1$ kHz	28	—	dB