

# HiPerFAST™ IGBT Lightspeed™ Series

**IXGA 7N60C  
IXGP 7N60C**

$V_{CES} = 600 \text{ V}$   
 $I_{C25} = 14 \text{ A}$   
 $V_{CE(sat)} = 2.7 \text{ V}$   
 $t_{fi} = 45 \text{ ns}$

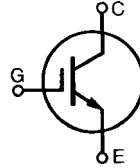

Symbol	Test Conditions	Maximum Ratings	
$V_{CES}$	$T_J = 25^\circ\text{C to } 150^\circ\text{C}$	600	V
$V_{CGR}$	$T_J = 25^\circ\text{C to } 150^\circ\text{C}; R_{GE} = 1 \text{ M}\Omega$	600	V
$V_{GES}$	Continuous	$\pm 20$	V
$V_{GEM}$	Transient	$\pm 30$	V
$I_{C25}$	$T_C = 25^\circ\text{C}$	14	A
$I_{C90}$	$T_C = 90^\circ\text{C}$	7	A
$I_{CM}$	$T_C = 25^\circ\text{C}, 1 \text{ ms}$	30	A
<b>SSOA (RBSOA)</b>	$V_{GE} = 15 \text{ V}, T_{VJ} = 125^\circ\text{C}, R_G = 22 \Omega$ Clamped inductive load, $L = 300 \mu\text{H}$	$I_{CM} = 14$ @ $0.8 V_{CES}$	A
$P_C$	$T_C = 25^\circ\text{C}$	54	W
$T_J$		-55 ... +150	C
$T_{JM}$		150	C
$T_{stg}$		-55 ... +150	C
Maximum lead temperature for soldering 1.6 mm (0.062 in.) from case for 10 s		300	C
$M_d$	Mounting torque, (TO-220)	M3 M3.5	0.45/4 Nm/lb.in. 0.55/5 Nm/lb.in.
<b>Weight</b>	TO-220		4 g
	TO-263		2 g

**TO-220AB (IXGP)**

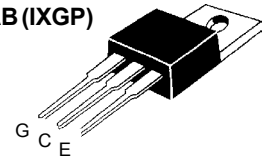

**TO-263 AA (IXGA)**

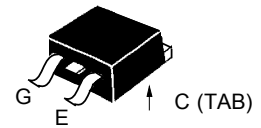

G = Gate, C = Collector,  
E = Emitter, TAB = Collector

### Features

- International standard packages JEDEC TO-263 surface mountable and JEDEC TO-220 AB
- High frequency IGBT
- High current handling capability
- HiPerFAST™ HDMOS™ process
- MOS Gate turn-on - drive simplicity

### Applications

- Uninterruptible power supplies (UPS)
- Switched-mode and resonant-mode power supplies
- AC motor speed control
- DC servo and robot drives
- DC choppers

### Advantages

- High power density
- Suitable for surface mounting
- Very low switching losses for high frequency applications

Symbol	Test Conditions	Characteristic Values ( $T_J = 25^\circ\text{C}$ , unless otherwise specified)		
		min.	typ.	max.
$BV_{CES}$	$I_C = 250 \mu\text{A}, V_{GE} = 0 \text{ V}$	600		V
$V_{GE(th)}$	$I_C = 250 \mu\text{A}, V_{CE} = V_{GE}$	2.5		5.5 V
$I_{CES}$	$V_{CE} = 0.8 \cdot V_{CES}$ $V_{GE} = 0 \text{ V}$	$T_J = 25^\circ\text{C}$		100 $\mu\text{A}$
		$T_J = 125^\circ\text{C}$		500 $\mu\text{A}$
$I_{GES}$	$V_{CE} = 0 \text{ V}, V_{GE} = \pm 20 \text{ V}$			$\pm 100 \text{ nA}$
$V_{CE(sat)}$	$I_C = I_{C90}, V_{GE} = 15 \text{ V}$	2.0	2.7	V

Symbol	Test Conditions	Characteristic Values ( $T_J = 25^\circ\text{C}$ , unless otherwise specified)		
		min.	typ.	max.
$g_{fs}$	$I_C = I_{C90}, V_{CE} = 10\text{ V}$ , Pulse test, $t \leq 300\ \mu\text{s}$ , duty cycle $\leq 2\%$	3	7	S
$C_{ies}$	$V_{CE} = 25\text{ V}, V_{GE} = 0\text{ V}, f = 1\text{ MHz}$		500	pF
$C_{oes}$			50	pF
$C_{res}$			17	pF
$Q_g$	$I_C = I_{C90}, V_{GE} = 15\text{ V}, V_{CE} = 0.5 V_{CES}$		25	nC
$Q_{ge}$			5	nC
$Q_{gc}$			10	nC
$t_{d(on)}$	<b>Inductive load, <math>T_J = 25^\circ\text{C}</math></b> $I_C = I_{C90}, V_{GE} = 15\text{ V}, L = 300\ \mu\text{H}$ , $V_{CE} = 0.8 V_{CES}, R_G = R_{off} = 22\ \Omega$ Remarks: Switching times may increase for $V_{CE}$ (Clamp) $> 0.8 \cdot V_{CES}$ , higher $T_J$ or increased $R_G$		9	ns
$t_{ri}$			10	ns
$E_{on}$			0.07	mJ
$t_{d(off)}$			65	130 ns
$t_{fi}$			45	110 ns
$E_{off}$			0.12	0.25 mJ
$t_{d(on)}$	<b>Inductive load, <math>T_J = 125^\circ\text{C}</math></b> $I_C = I_{C90}, V_{GE} = 15\text{ V}, L = 300\ \mu\text{H}$ $V_{CE} = 0.8 V_{CES}, R_G = R_{off} = 22\ \Omega$ Remarks: Switching times may increase for $V_{CE}$ (Clamp) $> 0.8 \cdot V_{CES}$ , higher $T_J$ or increased $R_G$		10	ns
$t_{ri}$			15	ns
$E_{on}$			0.07	mJ
$t_{d(off)}$			120	ns
$t_{fi}$			85	ns
$E_{off}$			0.22	mJ
$R_{thJC}$				2.3 K/W
$R_{thCK}$	(TO-220)		0.25	K/W

### TO-220 AB Outline

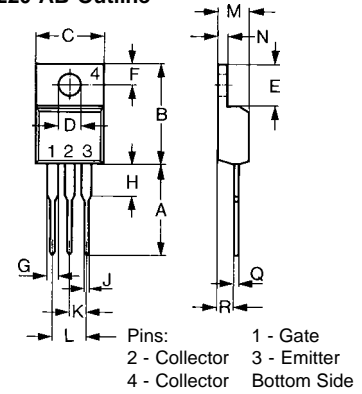

Dim.	Millimeter		Inches	
	Min.	Max.	Min.	Max.
A	12.70	13.97	0.500	0.550
B	14.73	16.00	0.580	0.630
C	9.91	10.66	0.390	0.420
D	3.54	4.08	0.139	0.161
E	5.85	6.85	0.230	0.270
F	2.54	3.18	0.100	0.125
G	1.15	1.65	0.045	0.065
H	2.79	5.84	0.110	0.230
J	0.64	1.01	0.025	0.040
K	2.54	BSC	0.100	BSC
M	4.32	4.82	0.170	0.190
N	1.14	1.39	0.045	0.055
Q	0.35	0.56	0.014	0.022
R	2.29	2.79	0.090	0.110

### TO-263 AA Outline

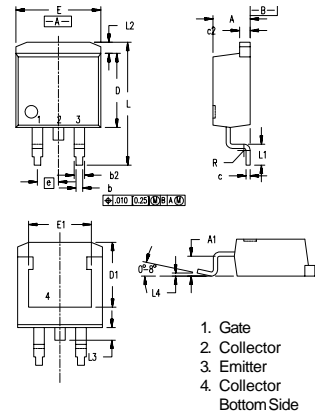

Dim.	Millimeter		Inches	
	Min.	Max.	Min.	Max.
A	4.06	4.83	.160	.190
A1	2.03	2.79	.080	.110
b	0.51	0.99	.020	.039
b2	1.14	1.40	.045	.055
c	0.46	0.74	.018	.029
c2	1.14	1.40	.045	.055
D	8.64	9.65	.340	.380
D1	7.11	8.13	.280	.320
E	9.65	10.29	.380	.405
E1	6.86	8.13	.270	.320
e	2.54	BSC	.100	BSC
L	14.61	15.88	.575	.625
L1	2.29	2.79	.090	.110
L2	1.02	1.40	.040	.055
L3	1.27	1.78	.050	.070
L4	0	0.38	0	.015
R	0.46	0.74	.018	.029

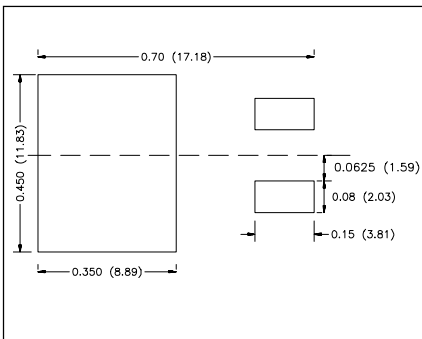

### Min. Recommended Footprint (Dimensions in inches and mm)

IXYS reserves the right to change limits, test conditions, and dimensions.