

GNSS ZOE CLICK

PID: MIKROE-3660
Weight: 24 g

GNSS ZOE Click is a evaluation board for ultra small ZOE-M8Q GNSS SiP receiver from u-blox. Thanks to u-blox's advanced algorithms and complete GNSS solution, the GNSS ZOE click meets even the most stringent requirements in versatile industrial and consumer applications, such as UAVs, vehicles and assets tracking, navigation devices based on GPS and GLONASS, road navigation devices, public transport, wearable devices, and many more. GNSS ZOE is mainly targeted for applications that require a small size device without compromising performance.

GNSS ZOE click is supported by a mikroSDK compliant library, which includes functions that simplify software development. This Click board™ comes as a fully tested product, ready to be used on a system equipped with the mikroBUS™ socket.

GNSS ZOE click features high precision GNSS, dual-frequency RF front-end, onboard serial flash memory, message integrity protection, anti-jamming, anti-spoofing, and many more, makes this Click board™ meet even the most stringent requirements in versatile industrial and consumer applications, such as UAVs, vehicles and assets tracking. For RF optimization, the ZOE-M8Q module features the integrated front-end SAW filter and an additional front-end LNA for increased jamming immunity and easier antenna integration. GNSS ZOE click is designed mainly for using with GNSS/GLONASS compatible active antennas.

HOW DOES IT WORK?

GNSS ZOE click features the ZOE-M8Q are u-blox's super small, highly integrated GNSS SiP (System in Package) modules based on the high performing u-blox M8 concurrent positioning engine. The ultra-miniature form factor integrates a complete GNSS receiver including SAW filter, LNA and TCXO. Incorporating ZOE-M8 into customer designs is simple and straightforward, thanks to the fully integrated design, single voltage supply, low power consumption, simple interface and sophisticated interference suppression that ensure maximum performance even in GNSS-hostile environments.

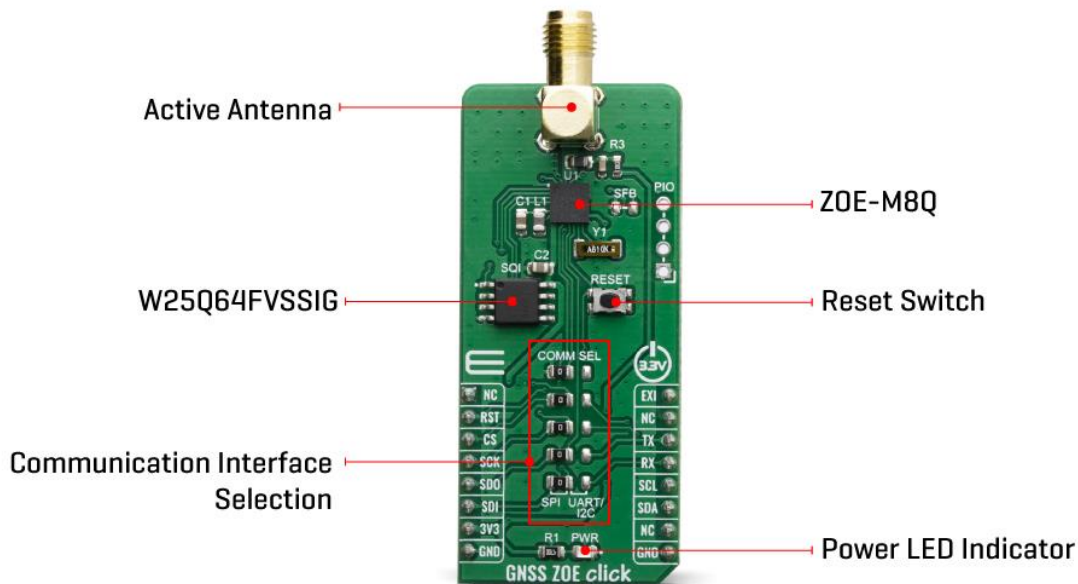

The ZOE-M8 GNSS SiPs are concurrent GNSS receivers which can receive and track multiple GNSS systems: GPS, Galileo, GLONASS and BeiDou. Owing to the dual-frequency RF front-end architecture, either GLONASS or BeiDou can be processed concurrently with GPS and Galileo signals, thereby providing reception of three GNSS systems. By default, the M8 receivers are configured for concurrent GPS and GLONASS, including SBAS and QZSS reception. If power consumption is a key factor, then the receiver should be configured for a single GNSS operation using GPS, Galileo, GLONASS or BeiDou and disabling QZSS and SBAS.

Thanks to onboard 64 Mbit SQI flash memory, GNSS ZOE click can also be used in data logging applications. The data logging feature enables continuous storage of position, velocity and time information to the flash memory. The information can be downloaded from the receiver later for further analysis or for conversion to a mapping tool. Besides the data logging feature, the flash memory can also be used for the AssistNow Offline service, which allows the users to download long-term orbit data over the Internet at their convenience and store it to the onboard 64 Mbit SQI flash memory.

The ZOE-M8 SiP supports both SPI and I2C/UART communication protocol configurations. Therefore, this Click board™ have communication interface selection jumpers, named COMM SEL, in order to allow the user to set whether to use SPI communication or I2C/UART combination. Note that there is five SMD jumpers and all of them should be in the same position.

The Click board™ can operate with 3.3V MCUs only, it is set to work over the I2C by default, and it is already equipped with the pull-up resistors. It is ready to be used as soon as it is inserted into a mikroBUS™ socket of the development system.

SPECIFICATIONS

Type	GPS/GNSS
Applications	UAVs, vehicles and assets tracking, navigation devices based on GPS and GLONASS, road navigation devices, public transport, wearable devices, and many more.
On-board modules	ZOE-M8Q are u-blox's super small, highly integrated GNSS SiP (System in Package) modules from u-blox
Key Features	High precision GNSS, dual-frequency RF front-end, onboard serial flash memory, message integrity protection, anti-jamming, anti-spoofing, and many more
Interface	I2C,SPI,UART
Input Voltage	3.3V
Click board size	L (57.15 x 25.4 mm)

PINOUT DIAGRAM

This table shows how the pinout on GNSS ZOE corresponds to the pinout on the mikroBUS™ socket (the latter shown in the two middle columns).

Notes	Pin					Pin	Notes
	NC	1	AN	PWM	16	EXI	External Interrupt
Reset module	RST	2	RST	INT	15	NC	
SPI Chip Select	CS	3	CS	RX	14	RX	UART Receive
SPI Clock	SCK	4	SCK	TX	13	TX	UART Transmit
SPI SDO	SDO	5	MISO	SCL	12	SCL	I2C Clock
SPI SDI	SDI	6	MOSI	SDA	11	SDA	I2C data
Power Supply	3.3V	7	3.3V	5V	10	NC	
Ground	GND	8	GND	GND	9	GND	Ground

ONBOARD SETTINGS AND INDICATORS

Label	Name	Default	Description
LD1	PWR	-	Power LED Indicator
JP1- JP5	COMM SEL	Left	Communication interface selection: left position SPI, right position UART/I2C

SOFTWARE SUPPORT

We provide a library for the GNSS ZOE click on our LibStock page, as well as a demo application (example), developed using MikroElektronika compilers. The demo can run on all the main MikroElektronika development boards.

Library Description

This library allows user to perform a control of the GNSS ZOE click board. Also user can check the indication status from the charger to get charging state. Fault condition also can be checked. For more details check documentation.

Key functions:

- `void gnsszoe_spi_get(uint8_t * register_buffer, uint16_t number_of_registers)` - gets specified number of register values and stores those values into register buffer.
- `uint8_t gnsszoe_uart_get(void)` - receives bytes via UART.
- `void gnsszoe_i2c_get(uint8_t register_address, uint8_t * register_buffer, uint16_t number_of_registers)` - gets specified number of register values and stores those values into register buffer.

Examples description

The application is composed of three sections :

- System Initialization - Initializes GPIO pins, SPI, UART, I2C and LOG modules.
- Application Initialization - Initializes SPI, UART, I2C driver and resets the device .
- Application Task - Executes `gnsszoe_task()` function.
-

```
void gnsszoe_task( )
{
    if (communication_module == _GNSSZOE_MODULE_SPI)
    {
        gnsszoe_spi_capture( );
    }
    else if (communication_module == _GNSSZOE_MODULE_UART)
    {
        gnsszoe_uart_capture( );
    }
    else if (communication_module == _GNSSZOE_MODULE_I2C)
    {
        gnsszoe_i2c_capture( );
    }
}
```

```
else
{
    mikrobus_logWrite( "> Setup error", _LOG_LINE );
}
gnsszoe_parse( );
}
```

Additional Functions :

- gnsszoe_spi_capture() - Captures message bytes via SPI interface
- gnsszoe_wait_for_uartReady() - Waits for UART ready indication
- gnsszoe_uart_capture() - Captures message bytes via UART interface
- gnsszoe_i2c_capture() - Captures message bytes via I2C interface
- gnsszoe_parse() - Parses received message
- gnsszoe_task() - Executes gnsszoe_XXX_capture() and gnsszoe_parse() functions

The full application code, and ready to use projects can be found on our LibStock page.

Other mikroE Libraries used in the example:

- SPI
- I2C
- UART
- Conversionst

Additional notes and informations

Depending on the development board you are using, you may need USB UART click, USB UART 2 click or RS232 click to connect to your PC, for development systems with no UART to USB interface available on the board. The terminal available in all MikroElektronika compilers, or any other terminal application of your choice, can be used to read the message.

MIKROSDK

This Click board™ is supported with mikroSDK - MikroElektronika Software Development Kit. To ensure proper operation of mikroSDK compliant Click board™ demo applications, mikroSDK should be downloaded from the LibStock and installed for the compiler you are using.

For more information about mikroSDK, visit the official page.

DOWNLOADS

mikroBUS™ Standard specification

LibStock: mikroSDK

Click board catalog

GNSS ZOE click example on Libstock

GNSS ZOE click schematic

GNSS ZOE click 2D and 3D files

ZOE-M8 datasheet



<https://www.mikroe.com/gnss-zoe-click/7-16-19>