

RECOMMENDED MOUNTING HARDWARE

PCB THICKNESS	SCREW LENGTH	SCREW SIZE	FLAT WASHER SPEC.S (DIN 9021)	BELLEVILLE WASHER SPEC.S (DIN 6796)
0.063"	6.0mm	M3	MAT'L: STAINLESS STEEL WASHER OUTER DIA.: 9.0mm WASHER INNER DIA.: 3.2mm	MAT'L: STAINLESS STEEL WASHER OUTER DIA.: 7.0mm WASHER INNER DIA.: 3.2mm
0.093"	8.0mm	M3	WASHER THICKNESS: 0.7mm	WASHER THICKNESS: 0.6mm
0.125"	8.0mm	M3		

NOTES:

1. MATERIAL: LCP, GLASS FILLED, BLACK, CONTACTS: COPPER ALLOY
2. PLATING: SEE CHART
3. PRODUCT SPECIFICATION: PS-76001-001.
4. PACKAGING SPECIFICATION: PK-76001-901.
5. TO REMOVE FROM PCB, SEE Z-POWER EXTRACTION TOOL INSTRUCTION SHEET ATS-621005300. USE EXTRACTION TOOL 621005300.

- * SCREW MAT'L: STAINLESS STEEL
- * RECOMMENDED TORQUE = .75Nm/6.6In-Lbs.

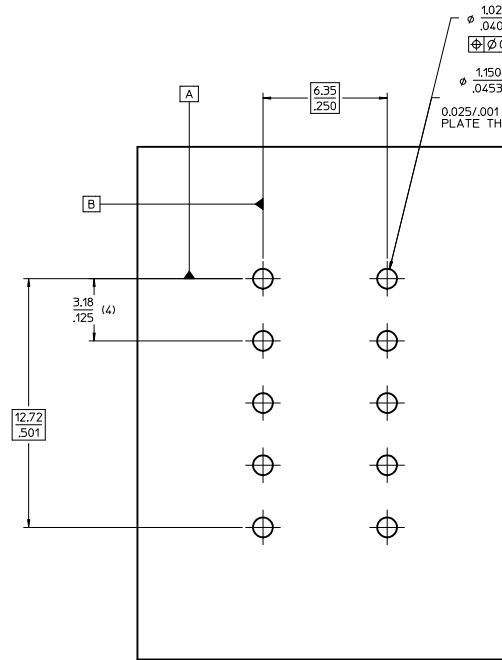
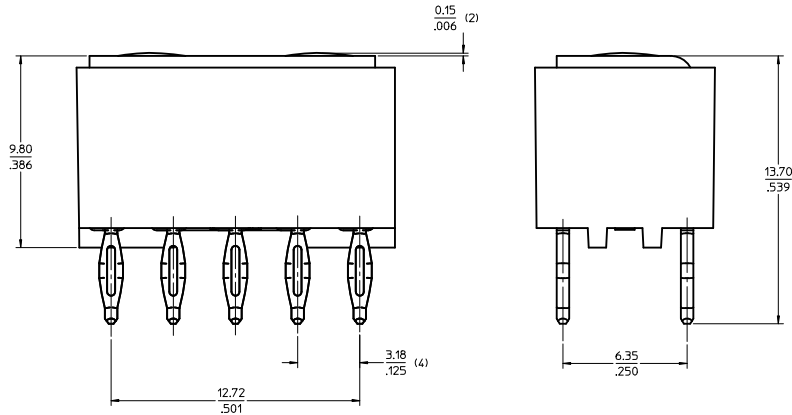
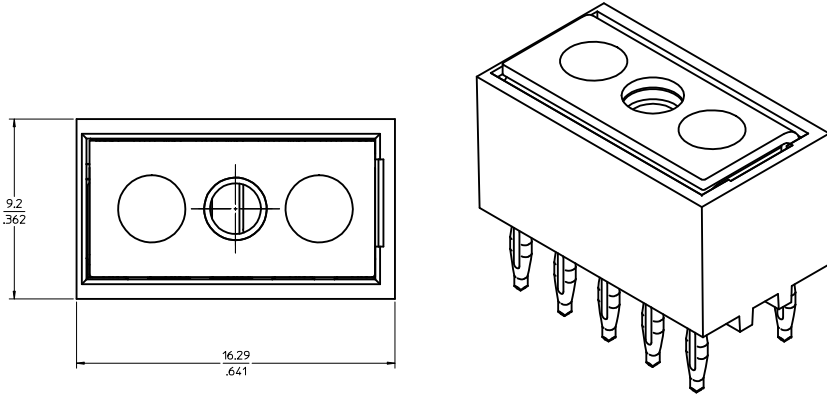

RECOMMENDED PCB FOOT PRINT LAYOUT
 PCB THICKNESS 2.36/.093 MIN
 PCB COMPLIANT TAIL INSERTION FORCE
 = 20LBS PER TAIL

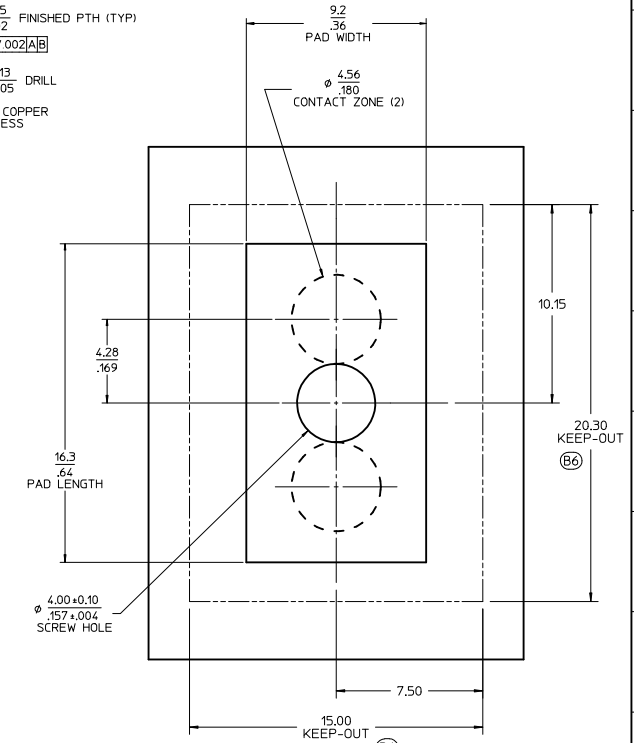

RECOMMENDED PCB PAD LAYOUT

PART NUMBER	DESCRIPTION	PLATING
76001-0010	GOLD PLATED	SELECT GOLD: 30µ IN MIN SELECT MATTE TIN: 100µ IN MIN BOTH OVER NICKEL: 50µ IN MIN
76001-0110	TIN PLATED	MATTE TIN OVERALL: 100µ IN MIN NICKEL UNDERPLATE: 50µ IN MIN

Ⓢ

ADD PCB KEEP-OUT DEC NO: UCP2011-1320 DRAWN: BHANDRA CHKD: APATEL APPR: APATEL DATE: 2010/11/15 REV: B6	QUALITY SYMBOLS	GENERAL TOLERANCES (UNLESS SPECIFIED)	DIMENSION STYLE	SCALE	DESIGN UNITS	THIRD ANGLE PROJECTION	
	∇=0 ∇=0 ∇=0	mm: ±.02 INCH: ±.005 ANGULAR: ±1/2°	MM/IN	8:1	METRIC	DRAWN BY: DMCGOWAN CHECKED BY: MSANDBERG APPROVED BY: APATEL DATE: 2005/11/07 DATE: 2006/02/04 DATE: 2010/11/15	TITLE: Z-POWER 10 TAIL ASSEMBLY MOLEX INCORPORATED
	DRAFT WHERE APPLICABLE MUST REMAIN WITHIN DIMENSIONS			MATERIAL NO. SEE CHART	DOCUMENT NO. SD-76001-001	SHEET NO. 1 OF 1	
	THIS DRAWING CONTAINS INFORMATION THAT IS PROPRIETARY TO MOLEX INCORPORATED AND SHOULD NOT BE USED WITHOUT WRITTEN PERMISSION						