

SS Stainless Steel

3 Type

- L** Fixing angle piece left
- R** Fixing angle piece right

Metric table

2

Dimensions in: millimeters - inches

l ₁	d	h ₁	h ₂	h ₃	l ₂	l ₃	l ₄	l ₅	l ₆	l ₇	l ₈	l ₉	m ₁	m ₂	r	s	x	y
40	5.3	7.5	28	2.5	26	36	70.1	105.2	74.5	27.4	101.9	16	25	5	78.5	4	13	29.5
1.57	.21	.30	1.10	.10	1.02	1.42	2.76	4.14	2.93	1.08	4.01	.63	.98	.20	3.09	.16	.51	1.16
50	6.5	10	35	2.5	35	46	92.3	140	102.8	39.3	134.7	27.8	30	6	105	5	18	38
1.97	.26	.39	1.38	.10	1.38	1.81	3.63	5.51	4.05	1.55	5.30	1.09	1.18	.24	4.13	.20	.71	1.50
60	8.5	12.5	40	2.5	40	61	116.5	179.5	125.2	51.3	172.2	37.2	36	8	137.5	5	19	47
2.36	.33	.49	1.57	.10	1.57	2.40	4.59	7.07	4.93	2.02	6.78	1.46	1.42	.31	5.41	.20	.75	1.85

Specification

1

4

- Body
Stainless steel **NI**
European Standard No. 1.4301 (AISI 304)
Matte tumbled finish **MT**
- Friction bearing
Bronze, self-lubricated
- **RoHS compliant**

On request

- Other opening angles
- Other fixing angle pieces
- Other materials
- Other finishes
- Other max. wall thicknesses
- Other lifting motion
- With pneumatic spring connection

Information

GN 7237 stainless steel multiple-joint hinges are installed on the inside of flaps, hatches and doors to save space and ensure protection against vandalism. The hinges have a maximum opening angle of 180°, which provides optimal accessibility and avoids the blocking of escape routes by open doors, for example.

Use of this hinge type leaves housing exteriors free of attachments that do not match the design or that should be avoided entirely in the interests of fast and easy cleaning.

Stainless steel multiple-joint hinges are generally used in pairs, meaning that one Type L and one type R are used per opening. For higher loads, e.g. from large hatches, these can be supplemented with additional hinges of either type.

see also...

- *Construction Instructions and Load Capacity*
- *Spacer Plates GN 2370 (Stainless Steel)*
- *Stainless Steel Spacer Plates GN 2372 (Stainless Steel, with Tapped Insert)*
- *Stainless Steel Spacer Plates GN 2376 (with Threaded Studs)*

How to order

GN 7237-NI-40-L-MT

1	Material
2	Length l₁
3	Type
4	Finish

Installation position – pivot characteristics

The stainless steel multiple-joint hinges can be installed to the housing either with slotted holes on the fixing angle piece that are either perpendicular or parallel to the hinge axis. This results in the two pivot characteristics depicted.

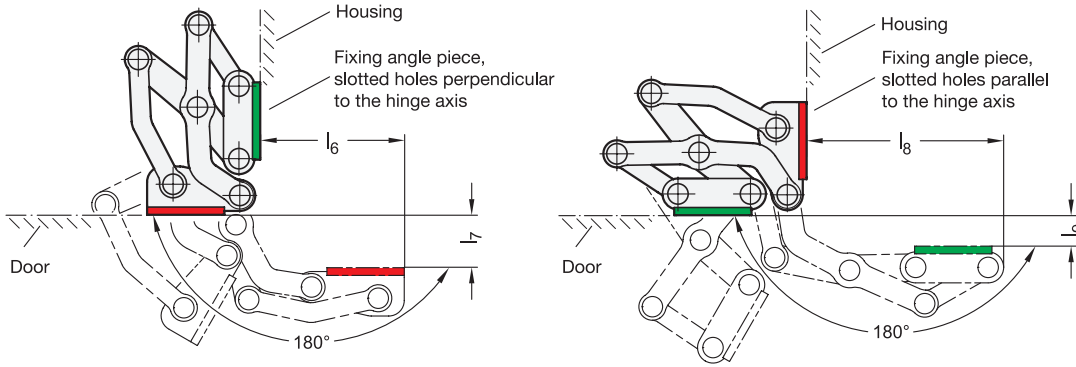

Application examples

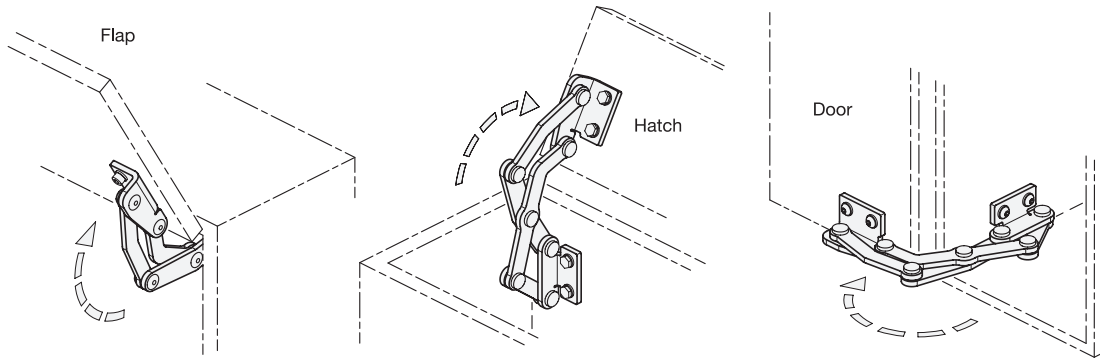

Adjustment and fastening options

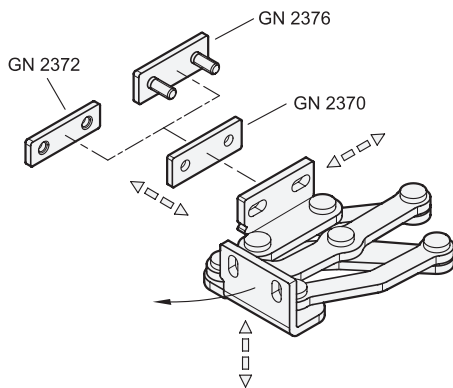

The stainless steel multiple-joint hinges can be adjusted in three planes during installation. For example, this allows adjustment for tolerances or establishing of required compressive forces for seals.

Two planes can be adjusted via parallel or perpendicular slotted holes in the fixing angle pieces. In the third plane, position corrections can be made using the GN 2370 stainless steel spacer plates.

GN 2372 stainless steel spacer plates with tapped holes as well as GN 2376 stainless steel spacer plates with threaded studs are also available for fastening the hinges. The latter can be welded on or inserted through the wall from the outside and fastened in place. All accessory items are designed for use with both fixing angle pieces.

3.1
3.2
3.3
3.4
3.5
3.6
3.7
3.8
3.9
3.10

Design variants

Flaps, hatches and doors can be inset, surface-mounted or mitered. The maximum wall thicknesses and bend sizes for planned sheet metal constructions arise from the respective installation type.

1. Fixing angle pieces mounted to the housing with slotted holes perpendicular to the hinge axis:

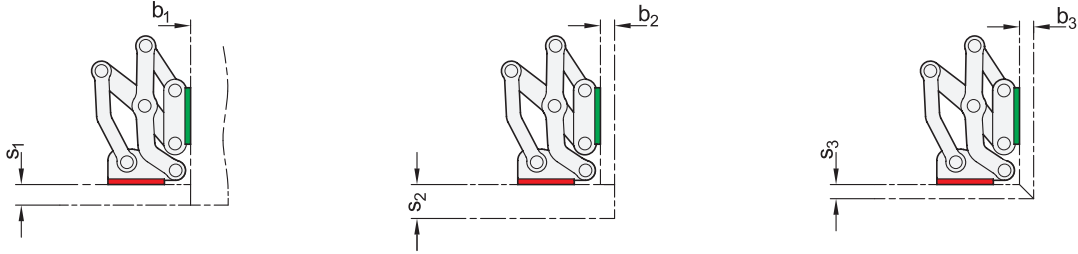

l_1	s_1 max.	b_1	s_2 max.	b_2 max.	s_3 max.	b_3 max.
40 1.57	13 .51	1 ... ∞	24 .94	10 .39	10 .39	10 .39
50 1.97	19 .75	1 ... ∞	34 1.34	17 .67	16 .63	16 .63
60 2.36	25 .98	1 ... ∞	44 1.73	24 .94	21 .83	21 .83

2. Fixing angle pieces mounted to the housing with slotted holes parallel to the hinge axis:

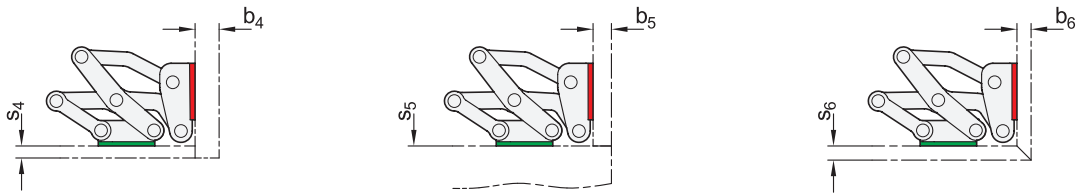

l_1	s_4 max.	b_4 max.	s_5	b_5 max.	s_6 max.	b_6 max.
40 1.57	9 .35	27 1.06	1 ... ∞	13 .51	10 .39	10 .39
50 1.97	17 .67	35 1.38	1 ... ∞	19 .75	16 .63	16 .63
60 2.36	23 .91	45 1.77	1 ... ∞	25 .98	21 .83	21 .83

The design variants shown represent standard installation conditions. If the installation position of the hinge is changed or one of the two wall thickness dimensions s or b are lower, the maximum achievable dimensions change independently of each other. This makes it possible in some cases to work with larger wall thickness dimensions than those specified with the same hinge size. A simple design check via CAD or a test setup is therefore recommended.

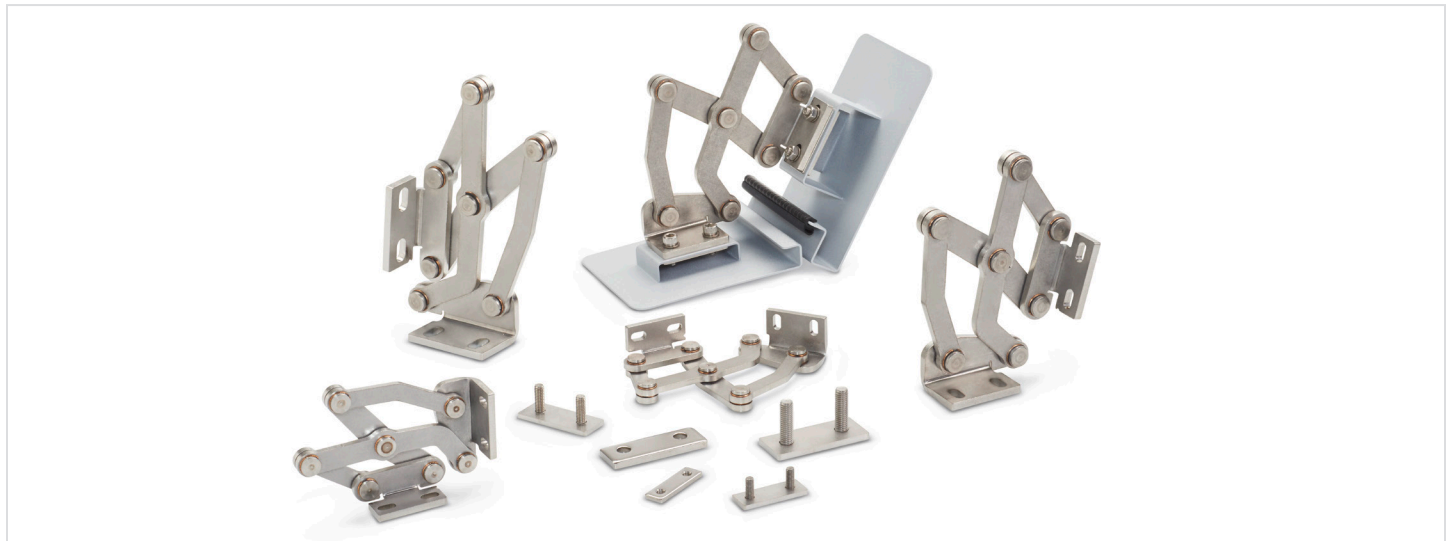

Construction assembly

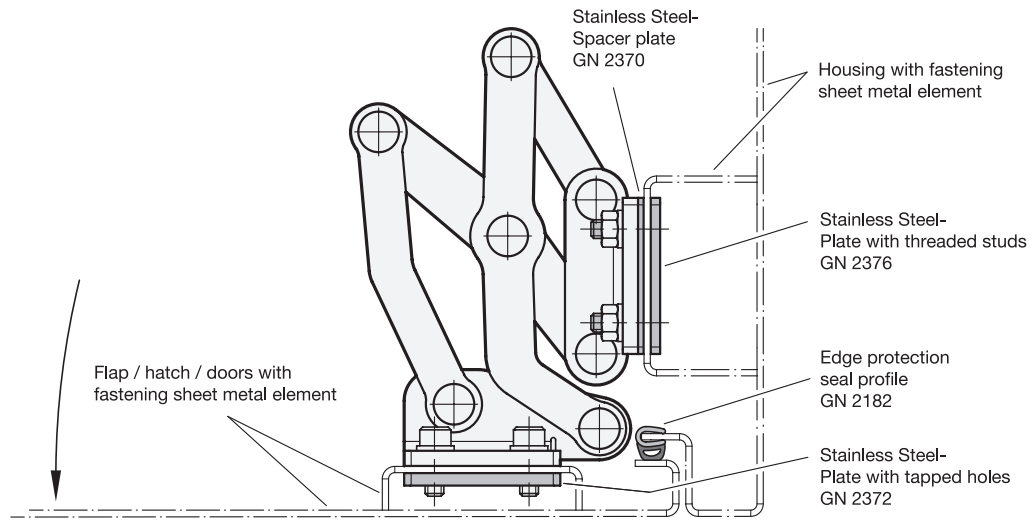

Load capacity

The maximum load of the stainless steel multiple-joint hinges specified below applies to the standard use cases and serves for orientation in the case of deviating applications. The resulting forces lead to slight elastic deformation, which can be compensated for by means of the adjustment options, if necessary.

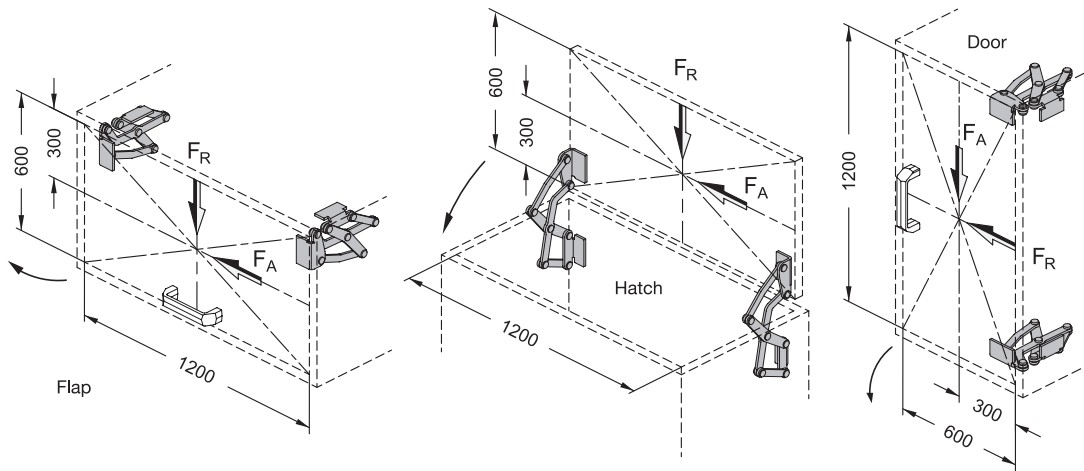

Load capacity per hinge pair		
I_1	F_A (axial)	F_R (radial)
40 N <i>8.99 lbf</i>	125 N <i>28.10 lbf</i>	450 N <i>101.16 lbf</i>
50 N <i>11.24 lbf</i>	125 N <i>28.10 lbf</i>	600 N <i>134.89 lbf</i>
60 N <i>13.49 lbf</i>	125 N <i>28.10 lbf</i>	450 N <i>101.16 lbf</i>