

Infrared Sensing Solutions

New, Updated Edition 4.1

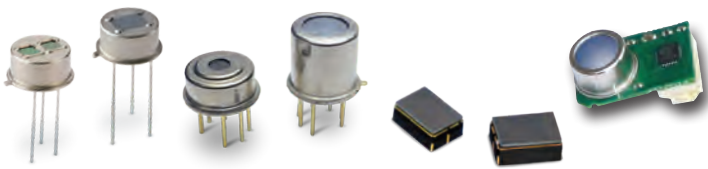

Motion Detection, Presence Monitoring,
Temperature Measurement
and Gas Detection.

EXCELITAS
TECHNOLOGIES®

Infrared Sensing Technologies

For Your Cutting-edge Applications.

Excelitas infrared sensing technologies play a vital role in creating a healthier, cleaner and safer tomorrow. Excelitas is world renowned for the design and production of high-performance pyroelectric detectors, thermopile detectors and sensor modules which – every day – contribute to safeguarding homes, saving energy, and providing comfort. From motion and presence detection to gas detection, thermometry and indoor climate control applications, our cutting edge IR sensing technologies and growing IR product range are meeting your challenges. We are sensing what you need for your cutting-edge applications.

Sensing what you need – from motion sensors for secure homes to gas detection systems, indoor climate control systems and ear thermometers.

Our Infrared Sensing Solutions provide:

- Excellent performance
- Strong reliability
- Innovative features

We support our products with:

- Applications expertise
- Suitable features and functions
- Special optical filters for gas sensing

■ **WORLDWIDE COMMITMENT TO YOUR CHALLENGES**

You can depend on Excelitas' world-class global network of optoelectronic production, R&D, and distribution centers for detection technologies including Montreal, Canada; Wiesbaden, Germany; Singapore; Batam, Indonesia; and Shenzhen, China. We have customer service hubs conveniently located on each continent to ensure just-in-time delivery. We believe in forging a collaborative partnership in which we are communicating proactively with you and refining our forecasts to your requirements to better serve you.

We have the detection technologies and capabilities needed to enhance and accelerate your OEM designs. Our R&D groups are focusing on new product innovations and capabilities to meet your new and emerging applications. We pride ourselves on deep application expertise to respond to and anticipate your detection requirements. Feel confident that you can discuss your requirements with our engineers. We thrive on addressing your challenges and will always try to provide you with responsive assistance based on our know-how and expertise.

■ **UNPARALLELED QUALITY**

The consistent quality of our products is the foundation upon which we build our relationship with you. Market-wide adoption of our leading-edge detectors in a host of consumer products as well as medical, industrial and commercial applications is testimony to our quality commitment and to your confidence in us.

We implement cutting-edge quality assurance systems and measures; SPC and reliability testing are standard procedures at Excelitas. Of course, everything begins with the quality of our raw materials. Inspection procedures transcend all processes and conclude with 100% final inspection for all major parameters. We maintain our certification to major quality and environmental standards, which are subject to regular audits. All of our factories have received certifications for ISO 9001, OHSAS 18001, NLF/ILO-OSH 2001.

IR SENSING FOR YOUR DAILY LIFE	4
INFRARED BASICS	6
PYROELECTRIC DETECTOR TECHNIQUES	8
Pyroelectric Detectors Standard Analog Range and Data	10
Introduction to DigiPyro®	14
DigiPyro Product Range Dual Element and Data	15
DigiPyro Product Range Four Element and Data	18
THERMOPILE DETECTOR TECHNIQUES	20
Thermopile Detectors Range and Data	22
Thermopile Sensors DigiPile™ SMD	28
CaliPile® Sensors and Data	29
Thermopile Sensors DigiPile	32
Thermopile Modules TPML™	34
GAS MONITORING AND SPECTRAL FILTERS	36
Pyroelectric Detector Data for Gas Monitoring Systems	37
Thermopile Data for Gas Monitoring Systems	40
HANDLING AND PRECAUTIONS	42
RECOMMENDATION & SELECTION GUIDE	43

Applications and design ideas with IR Sensors



Smart Home

Private homes are an ideal application space for smart sensing products. Outdoor applications include automatic safety lighting to illuminate driveways, pathways and entrances, as well as motion-activated surveillance cameras and smart door bell cameras for home security and property surveillance.

Indoor applications can sense a car in the garage, trigger stairway lighting, and activate TV and PC monitors. Motion and presence activated heating, room air conditioners, and automatic wall switches for room lights require suited IR Sensors.

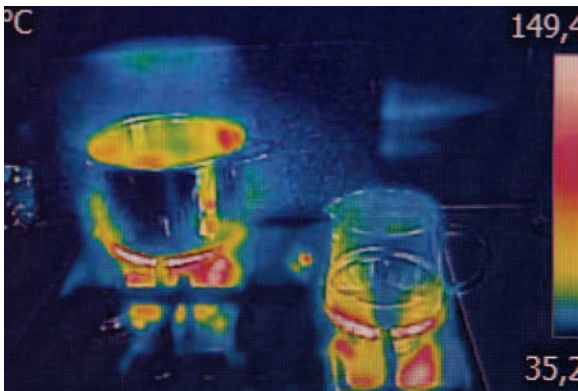

In the Kitchen

Modern kitchens are suited with many sophisticated devices and appliances for smart food preparation and storage. In addition to being a part of smart home infrastructure, the kitchen may be linked onto LAN or KNX bus. The equipment with its electronic control circuitry is perfectly suited to accomplish added functionalities by adding sensors. In refrigerators and freezers, food temperature can be controlled without probes to ensure optimal preservation. With microwave ovens, defrost and heating functions can be monitored and controlled with similar IR sensor applications. Stove-top cooking can also be monitored by various sensors and exhaust fans can be automatically activated for safety and comfort. Gas detectors alert us of dangerous gas concentrations for added safety in smart home infrastructures.



Home Health

One of the most popular IR sensing devices in our homes is fever temperature measuring using ear thermometers. The function is realized by a non-contact IR sensor measurement looking at the ear canal. A similar sensor is applied for a more easy measurement. The forehead thermometer is well suited to quicktest a baby's temperature without putting harm to the infant. In more clinical applications, IR sensor based gas monitors help during surgery to provide suitable breathing support.

For these applications Excelitas DigiPyro® and CaliPile® IR Sensors provide motion activation and presence monitoring to optimize energy usage in real time based upon human presence.

Public Buildings

Public facilities and buildings are an ideal space for smart sensing applications. As a more effective alternative to pre-defined clock dusk-to-dawn set lights, motion activated light controls offer the forefront of energy conservation and reduce light pollution. In storage buildings, high bay luminaire control saves significant amounts of power and money by activating lights only when a person is present in that sector.



In the Office

Offices require ample lighting to maximize efficient work spaces during operating hours. Often enough these lights are manually operated, or may be left on when work spaces are not in use. This presents a significant opportunity for power savings and economy gains if controlled by IR based presence sensors.

Motion detection, presence monitoring and high-bay luminaire controls represent the future of energy-efficient work environments. Monitor displays, PCs and AV equipment may be hibernated when users depart their terminals or meeting space and even HVAC can be sensor controlled for intelligent and dynamic room temperature controls based upon presence, sunlight shift and ambient temperatures.



Industry

All industrial processes require sensor-based supervision and control. Whenever heating processes are applied, non contact temperature measurement is the preferred method of collecting process data.

Gas monitors of various physical principles contribute to safe and controlled areas. Among critical gases, the infrared based NDIR gas sensor modules provide long-term stable measurement and reliability.

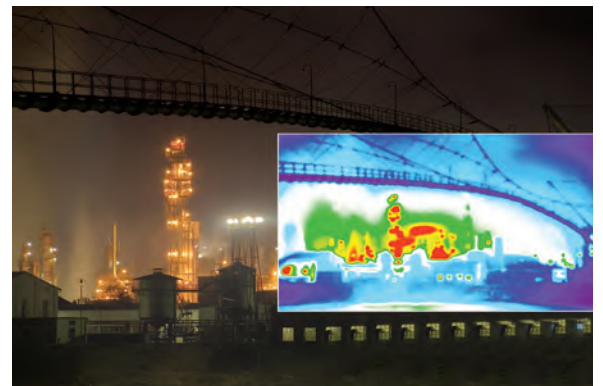

Infrared Basics

All solid bodies when having temperatures above the absolute zero (-273 °C) emit electromagnetic waves. The range of longer wave lengths beyond the visual spectrum is referenced as infrared radiation. Scientist Wilhelm Wien (1864–1928) has described the relation between a solid body's temperature and its emitting peak wave length by following equation:

$$\lambda_{\max} = 2898 / T$$

T = Temperature in K (Kelvin)
 λ = Wavelength in μm

With this formula the peak emission wave length of any material may be calculated.

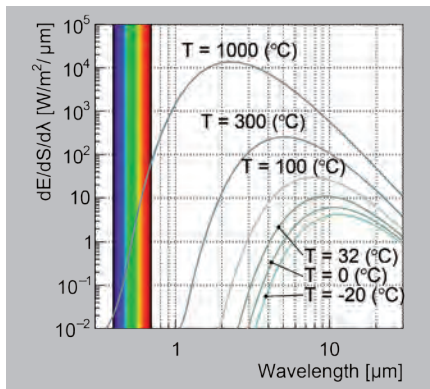

Fig 1: Radiated Energy vs. Wavelength

Max Planck (1858–1947) has described the relation between a solid body's surface temperature and its emitting wave length.

According to Max Planck, the intensity curve of all emitted wave lengths for a solid body is rather broad. For the case

of an ideal emitting body the emission spectrum is shown in Figure 1 for selected surface temperatures. Ideal emitters are called "black body".

With the naked eye we can see hot objects at about 1000°C glow red and we can feel the heat, whereas colder objects that cannot be seen glowing, still may emit heat. The human eye's sensitivity is limited to the so-called visible range of 300 to 750 nm. To detect the non-visible infrared-radiation, we need sensors that work in the range beyond, which is 1 μm and further. Typical sensors for motion detection use windows 5 μm to 14 μm .

Temperature Dependence

The radiation sent from emitting bodies is temperature dependent. There is another parameter which determines the body's surface property. With this Emissivity factor we can estimate the total emitted radiation power P of a warm object:

$$P_{\text{net}} \sim \epsilon T_{\text{obj}}^4 + (1 - \epsilon) T_{\text{amb}}^4$$

The radiated Power is proportional to its surface temperature T [Kelvin] to the Power of 4 and its emissivity. The emissivity ϵ of the surface of an ideal black body is 1. An opaque object with an emissivity lower than 1 (gray body) will additionally reflect the temperature of the ambient.

Hot objects generally dominate any total radiation over cold objects due to the power of 4 dependence.

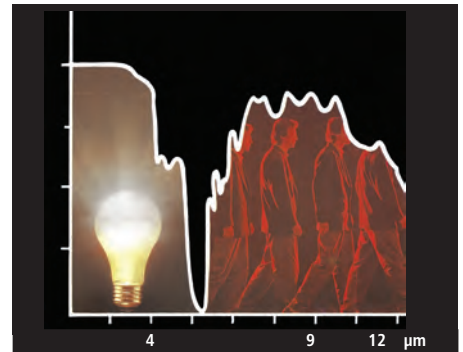

Spectral working range versus visible light

The Real World

The human skin as well as water have a very high emissivity in the far infrared of above 0.9. The peak emission for human skin temperature is around 10 μm and it is barely radiating below 3 μm .

Typically, specular objects are highly reflective in the infrared region and contribute less to the total radiation received from the objects surface temperature. Diffuse objects can have a high emissivity and are better suited for measuring their surface radiation. We further need to consider that properties in the visible spectrum may totally differ from the properties in the IR spectrum.

A human head with a surface temperature of approx. 35°C or 308 K calculates into a peak wavelength of 9.4 μm ; the body of a cat at 38°C temperature calculates to 9.3 μm . Pets like cat or dogs have similar body temperature. By this, their radiation is very similar to human, and it is not possible to distinguish humans from cats or dogs by their infrared spectrum.

Infrared Detectors

With detectors for the infrared spectrum there are two major classes by their physical principles: Photon Detectors and Thermal Detectors. Photon Detectors convert radiation directly into free electrons. Thermal Detectors receive radiation, transfer it to raising temperature of the sensing material which changes its electrical property in response to the temperature rise. Photon Detectors such as Photodiodes and Phototransistors range from visible to near infrared.



To detect the radiation of objects at typical ambient temperatures, and slightly above, simple photonic detectors based on PN-doped silicon structures such as CCD or CMOS will not work. Advanced technologies, specific for that use, separate into two major classes: **Photon Detectors** and **Thermal Detectors**. Photon Detectors convert radiation directly into electrons and are typically made from cooled exotic semiconducting materials - these detectors are not the scope of this overview.

Thermal Detectors receive radiation, transfer it to raising temperature of the sensing material which changes its electrical property. The spectral range is also dependant from the absorption of the material. These detectors have a broad response from below visible light up to over 100µm. Thermal Detectors are sensitive to the net radiation.

$$P_{net} = \epsilon T_{obj}^4 + (1 - \epsilon) T_{amb}^4 - T_{sens}^4$$

Fitted with special infrared windows as spectral filters they work in the mid to far infrared range without ambient visible light interference. Excelitas offers a variety of thermal detectors, including Pyrodetectors and Thermopile Detectors. Pyroelectric sensors require a modulated radiation over time in order to respond with a charge flow. While the response of pyroelectric sensors is generally higher than response of Thermopiles, Thermopiles provide a constant voltage output, which is proportional to the net radiation.

Both technologies respond to radiation changes within several milliseconds making them optimal to detect fast temperature modulations. Details are discussed in the corresponding sections.

Filters for Infrared Sensors

Material used for filters and windows must be transparent in the wavelength of interest. Glass for example is generally not suited to sense the temperature of human skin since it absorbs wavelengths above 4µm. Common materials with a broad transmission range are Germanium and Silicon for being used as the internal filter window for IR Sensors. For outside protection only few materials are suitable. Among many plastics, only PP or HD-PE can be used as protection or as fresnel structured optics for presence and motion detection.

Detectors by Excelitas Technologies are fitted with special infrared windows used as spectral filters. They work in the mid to far infrared range and usually block the visible range. Common applications in infrared reference wavelengths from 2 to 20µm. Thus the many windows allow transmission from 5-14µm. Infrared windows for pyrometric applications are defined for the atmospheric window. To avoid atmospheric absorption long range pyrometers apply a sharp cut-on/cut-off window of 8-14µm (G9).

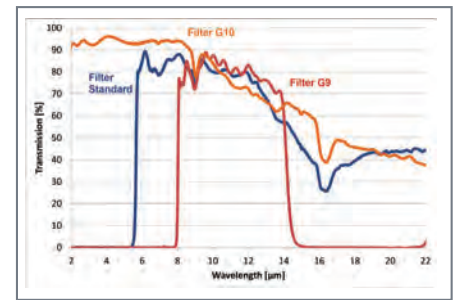

Fig.2

In Fig.2 we show the graph for standard infrared window and the “G9” window. For the special application of Gas Sensing by non-dispersive infrared absorption (NDIR) of a modulated radiation source we offer narrow band filters. The appropriate narrow band optical filters enable detection of Carbon Monoxide, Carbon Dioxide, Natural Gas and other environmental gases, as well as some technical gases. Please refer to the section dedicated to Gas Sensing for details.

Environmental Remarks

Thermal Detectors achieve best results at thermally stable conditions. This applies not only to the detector but also to the environmental conditions. Temperature gradients and temperature changes through direct and indirect heat transfer as well as other thermal influences shall be minimized in order to obtain best measurement results.

Pyroelectric Effect

Since ancient times the pyroelectric effect has been known as a property of ferroelectric materials. It is based on a specific behavior of dielectric materials, the phenomenon of a permanent electrical polarization. When changing temperature of such materials, this polarization will increase or decrease. We observe a charge displacement when applying electrodes to the surface.

This pyroelectric effect is the basic principle for detectors that can recognize temperature variations. The characteristic value for the permanent polarization, called pyroelectric coefficient, disappears above the Curie point.

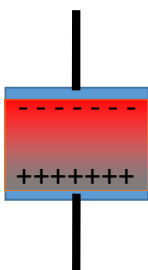

The Curie temperature limits the operation temperature range for such detectors. Pyroelectric detectors do not require cooling in order to operate.

Detector Design

Within our detectors, a thin slice of pyroelectric material is fitted with electrodes to form a capacitor. To compensate for ambient temperature changes, typically pairs of capacitors in opposed orientation are used.

Incoming radiation on one of the two paired elements will generate extremely low levels of thermal energy, so the pyroelectric current flow is rather small. It needs an amplification circuit to convert this small current into a convenient signal. Traditional analog detectors apply a high ohmic resistor and a dedicated low-leakage current FET in order to transform the high impedance of the detector material to a common output resistance. The pyroelectric element's

capacitance and the high gate resistance of the FET form an RC circuit with a time constant of about 1 second.

At very low frequencies the self-discharge dominates: with the electrical and thermal time constants the detector forms a band-pass like transfer function.

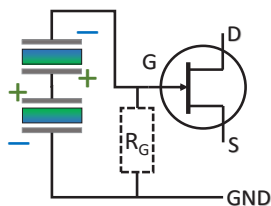

Dual Element Analog Detector with source follower circuit

Excelitas is the first to have introduced digital technology to Pyroelectric Detectors with its DigiPyro® family. A high-resolution ADC circuit provides direct analog to digital conversion. DigiPyro will drastically reduce your development and testing time. No further amplification chain is required and electro-magnetic interference (EMI) is significantly less severe.



Motion Detection

The most typical application of pyroelectric sensors is motion detection. Since only one of two compensating elements must be irradiated to generate a signal, pyroelectric sensors are placed behind optical components such as mirrors or multi-faceted Fresnel lenses.

A lens or mirror projects the thermal signature of the object onto the elements. Generally for long distance sensing long focal lengths are recommended.

For wall (horizontally) mounted applications, dual-element sensors (PYD) will give the best signal-to-noise performance. Optionally four (PYQ)

element sensors with dual output can be used allowing an advanced differential signal analysis.

Ceiling mounted applications require four element sensors with diagonally oriented elements. Best signal-to-noise performance is achieved with two separate channels, one for each element pair. As a cost effective alternative, a design with all four elements in a row with a single output can be used.

Detector Characteristics

The most important electrical data of the IR-Sensor are its responsivity, match and noise. Some special applications refer to NEP or D*.

Responsivity

As shown before, responsivity features a natural band-pass behavior with a maximum at about 0.1Hz radiation modulation. Excelitas measures the responsivity in front of a modulated black body while covering one of the two compensated elements. The result is provided as a voltage per radiation power V/W at a 1Hz modulation frequency, unless specified differently. That unit is not normalized to the active sensor area, which means that small element sizes will provide larger responsivity values as compared to large elements when using the same pyroelectric material.

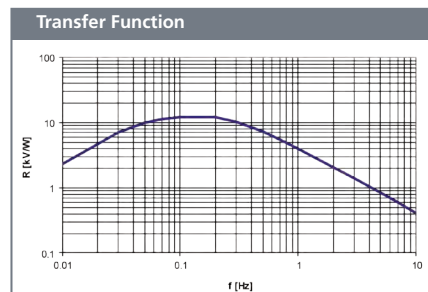

Example of transfer function of Dual Element Pyro

Match/ Common Mode Balance

The match between compensating elements of a pyroelectric detector indicates the ability for the "so-called" common mode rejection.

It is an important value for the performance of detectors, which are used for motion detection. It measures how well a signal can be suppressed when the origin is changing its temperature but not its position in the field-of-view. Stationary objects such as heaters will be rejected well when the match is low. The match is typically given as a signal by all illuminated elements of a detector relative to the responsivity of one element.



Noise

The noise of the sensor consists of three parts: the basic thermal noise of the sensing material, the (Johnson) noise of the high ohmic resistor and the input noise of the FET. The total output of these three parts is rather stable for temperatures below 40°C. Above this temperature, noise increases exponentially as a function of the temperature like it can be observed with typical other active electronic components. Noise is given in μV peak-to-peak or zero-peak.

Environmental Conditions

High humidity, condensation, dust or other radiation absorbing residuals will influence the detector performance. For the application of remote temperature measurement, generally it is required to have the sensor and all components around it at the same temperature as the ambient in order to calculate the correct absolute object temperature.

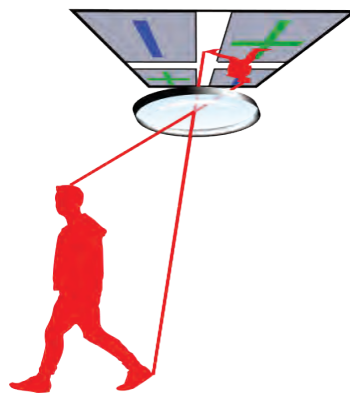

Example for a Four Element Detector

For the application of motion detection, the objects temperature must differ from the ambient in order to modulate the net radiation power over time.

Electro-Magnetic Interference

Like in any other component with small signals, EMI can influence the measurement results of thermal detectors. Metal TO-cans perform the best in difficult conditions. Excelitas digital solutions achieve the highest EMI tolerance since they do not require any additional amplification of analog signals.

The Analog Approach

A typical motion detection layout consist of five components. The analog detector signal requires an amplification stage in order to be processed. The amplification factor is typically above 1000 and is very sensitive to any electro-magnetic interference. It requires a very careful design and is very often the topic of last minute design changes when it comes to testing for conformity with international regulations.

Moreover, the signal is floating when ambient conditions change even slightly. Hence, a band-pass filter of typically 0.4 Hz to 10 Hz is applied prior to digitization with an ADC input stage. Finally, the signal analyzed for motion signatures meeting user defined criteria.

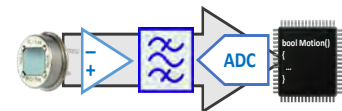

PYD 1378 • PYD 1388 • PYD 1398

Dual-Element Pyrodetectors

This Dual-Element Detector family offers standard TO-5 housings with varying window sizes. Whereas PYD 1378 is designed for economy and features a small optical window, PYD 1388 offers standard window size and is regarded as the standard Dual-Element Pyrodetector which is well suited for all kind of motion detection applications.

PYD 1398 with its even larger window size provides superior protection against white light interferences. PYD 1388 and PYD 1398 further provide an added 1kOhm Drain Resistor, which improves resistance to electromagnetic interferences, that may be introduced into the unit power supply. This makes PYD 1398 ideally suited for intrusion alarm applications.

Features and Benefits

- TO-5 metal housing
- Different window sizes
- EMI protection
- Suited for alarms and light switch applications

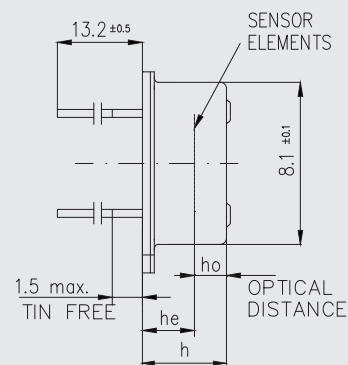
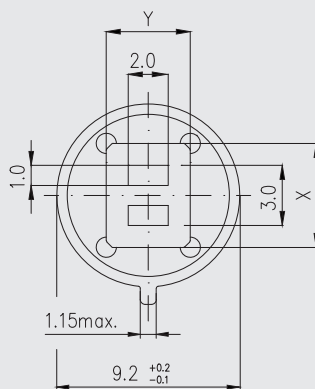
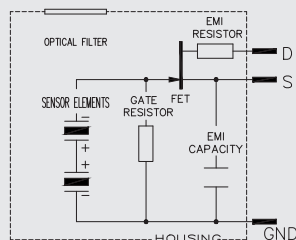

PYD 1378 - PYD 1388 - PYD 1398

Parameter	Symbol	PYD 1378	PYD 1388	PYD 1398	Unit	Remarks
Responsivity, min.	R_{min}	3.3	3.3	3.3	kV/W	$f = 1 \text{ Hz}$
Responsivity, typ.	R	4.2	4.2	4.2	kV/W	$f = 1 \text{ Hz}$
Match, max.	M_{max}	10	10	10	%	
Noise, max.	N_{max}	50	50	50	μV_{pp}	0.4...10Hz/20°C
Noise, typ.	N	25	25	25	μV_{pp}	0.4...10Hz/20°C
Source Voltage		0.2 ... 1.55	0.2 ... 1.55	0.2 ... 1.55	V	47 K Ω , 20°C, $V_{DD}=10V$
Operating Voltage		2.0...10	2.0...10	2.0...10	V	47 K Ω , 20°C
Field of View, horizontal	FoV	71°	95°	100°		unobstructed
Field of View, vertical		71°	87°	100°		unobstructed
Filter Size	X/Y	4.0 / 3.0	4.6 / 3.4	5.2 / 4.2	mm	
Housing height	h	4.2	4.2	4.2	mm	
Optical Element Location	he/ho	3.2 / 0.75	3.2 / 0.75	2.6 / 0.95	mm	h0= optical

PYD 1384 • PYD 1394

Dual-Element Pyrodetectors

This Dual-Element Detector series represents the low-profile, TO-39 housing version of the standard Pyro family and is available with two different window sizes. The PYD 1384 is designed for optimal economy in cost-sensitive applications while the PYD 1394 offers the standard window size for enhanced performance. The 1kOhm Drain Resistor included helps to reduce sensitivity against electromagnetic disturbances.

In both models, the low-profile TO-39 housing saves space and enables applications which require lens optics with small focal lengths. It is very suitable for placing two detectors at juxtaposed angles to one another other on a single PCB to provide wider fields of view such as 180°.

Features and Benefits

- TO-39 metal low-profile housing
- Different window sizes
- EMI protection
- Suited for motion detection

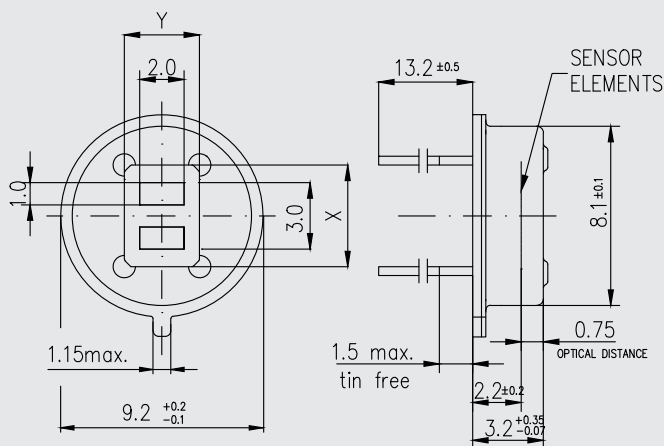
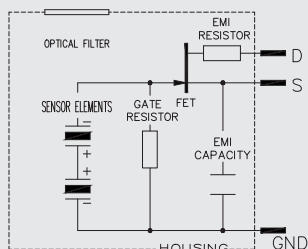

PYD 1384 - PYD 1394

Parameter	Symbol	PYD 1384	PYD 1394	Unit	Remarks
Responsivity, min.	R _{min}	3.3	3.3	kV/W	f = 1 Hz
Responsivity, typ.	R	4.2	4.2	kV/W	f = 1 Hz
Match, max.	M _{max}	10	10	%	
Noise, max.	N _{max}	50	50	µV _{pp}	0.4...10Hz/20°C
Noise, typ.	N	25	25	µV _{pp}	0.4...10Hz/20°C
Source Voltage		0.2 ... 1.55	0.2 ... 1.55	V	47 KΩ, 20°C, V _{DD} =10V
Operating Voltage		2.0...10	2.0...10	V	47 KΩ, 20°C
Field of View, horizontal	FoV	95°	110°		unobstructed
Field of View, vertical		87°	110°		unobstructed
Filter Size	X/Y	4.6 / 3.4	5.2 / 4.2	mm	
Optical Element Location	he/ho	2.2 / 0.75	2.2 / 0.75	mm	h0= optical



PYQ 1398 • PYQ 1348

Quad-Element Detectors, low-cost

This series of Four-Element “Quad” Detectors provides all four elements connected to one common output. This configuration enables specific applications in ceiling-mount locations when applied with suitable lens- or mirror-optic designs. Two different window options are available to accommodate different fields-of-view. PYQ 13## Quad-Element Detectors further provide added 1K Ohm Resistor in the drain connection and a built-in capacitor to ground. Both contribute to reduced sensitivity to electromagnetic disturbances.

The standard geometric element layout offers equal distance and spacing with cross polarity. Customized options of other polarities and geometries are available upon request.

Features and Benefits

- TO-5 metal housing
- Different window sizes
- EMI protection
- Designed for ceiling mount motion detection

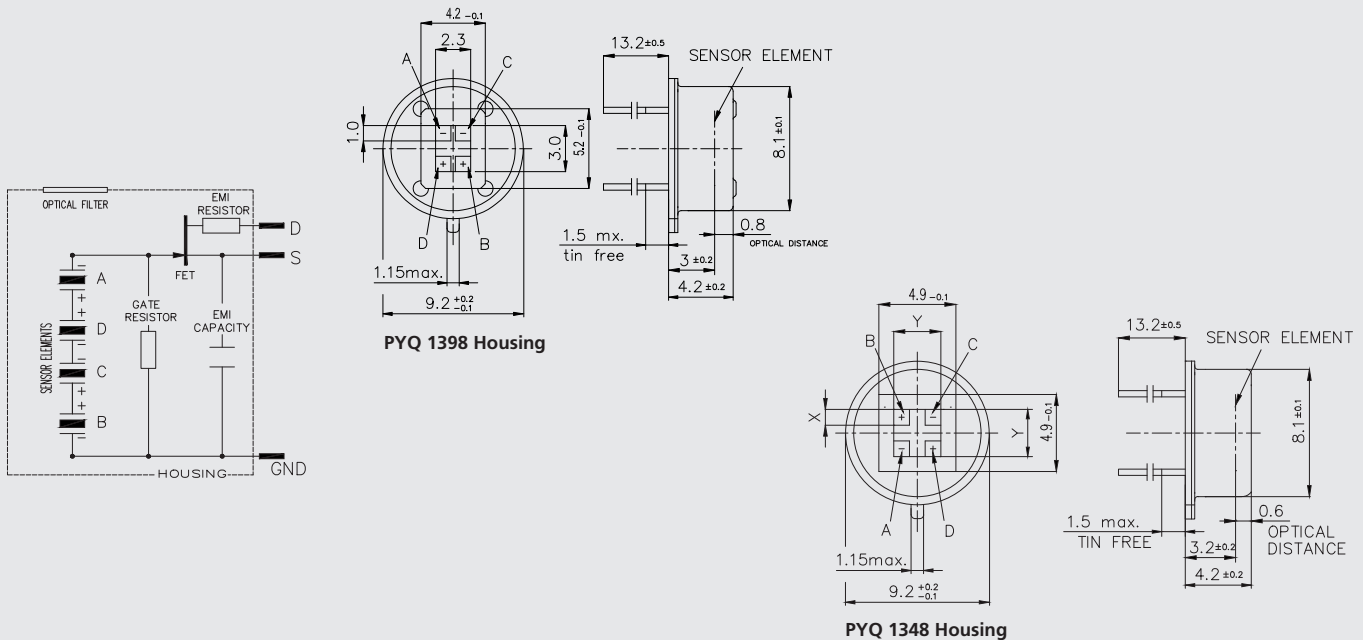

PYQ 1398 - PYQ1348

Parameter	Symbol	PYQ 1388	PYQ 1348	Unit	Remarks
Responsivity, min.	R_{min}	5.4	5.4	kV/W	f = 1 Hz
Responsivity, typ.	R	6.5	6.5	kV/W	f = 1 Hz
Match, max.	M_{max}	15	15	%	
Noise, max.	N_{max}	100	100	μV_{pp}	0.4...10Hz/20°C
Noise, typ.	N	40	40	μV_{pp}	0.4...10Hz/20°C
Source Voltage		0.2 ... 1.55	0.2 ... 1.55	V	47 K Ω , 20°C, $V_{DD}=10V$
Operating Voltage		2.0...10	2.0...10	V	47 K Ω , 20°C
Field of View, horizontal	FoV	103°	124°		unobstructed
Field of View, vertical		100°	124°		unobstructed
Filter Size	X/Y	5.2 / 4.2	4.9 / 4.9	mm	



PYQ 2498 • PYQ 5448

Quad-Element Pyro, Dual-Channel Output

This Detector family is distinguished by two pair of sensing elements, each with its individual output. As to the spacing of the sensing elements, various designs are available. The TO-5 housing is provided with suitable window size to accommodate the field-of-view of the element configuration.

Features and Benefits

- TO-5 metal housing
- Dual Channel Output
- Square / rectangular window options
- Customized Element configuration options
- Suitable for wall mount and ceiling mount applications

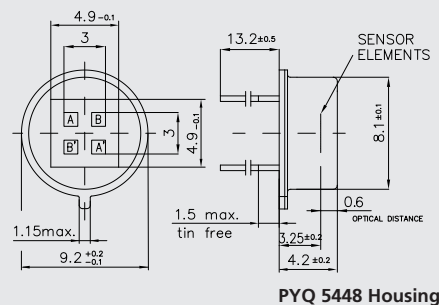
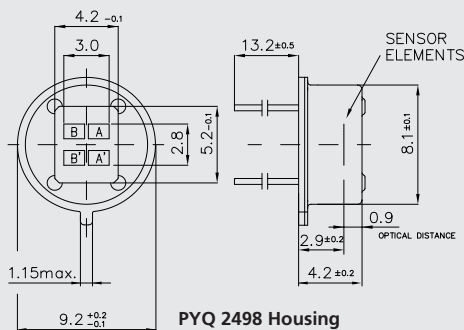
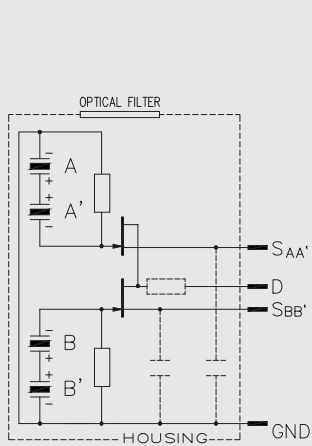

PYQ 2498 - PYQ 5448

Parameter	Symbol	PYQ 2498	PYQ 5448	Unit	Remarks
Responsivity, min.	R_{min}	3.5	4.4	kV/W	$f = 1 \text{ Hz}$
Responsivity, typ.	R	5.5	8	kV/W	$f = 1 \text{ Hz}$
Match, max.	M_{max}	15	15	%	
Noise, max.	N_{max}	75	75	μV_{pp}	0.4...10Hz/20°C
Noise, typ.	N	30	30	μV_{pp}	0.4...10Hz/20°C
Source Voltage		0.2 ... 1.55	0.2 ... 1.55	V	47 K Ω , 20°C, $V_{DD}=10\text{V}$
Operating Voltage		2.0...10	2.0...10	V	47 K Ω , 20°C
Field of View, horizontal	FoV	110°	95		unobstructed
Field of View, vertical		87°	95		unobstructed
Filter Size	X/Y	5.2 / 4.2	4.9 / 4.9	mm	

From Analog to Digital

Excelitas Technologies was the first to introduce a digital interface to pyroelectric sensors. The DigiPyro® family features a highly sensitive ADC input stage, which does not require further amplification. This allows for the lowest supply currents and is therefore ideal for energy efficient, battery operated applications. Selecting a digital sensor in a TO-can will significantly expedite your design process and lower the susceptibility to EMI. This is particularly important when you design a device with wireless communication features. Excelitas offers several digital solutions meeting various requirements.



DigiPyro

The simplest DigiPyro solution consists of a high-resolution ADC within the component housing. The data is transferred digitally through the proprietary direct link interface to the host system. In addition, an internal temperature reference channel is implemented in order to monitor component temperature changes. Excelitas offers one-channel (PYx x7xx series) and two-channel (PYx x8xx) solutions. While one-channel is optimal for dual-element sensors, two-channels allow for differential signal analysis with four-channel detectors.

Typically, a digital band-pass filter is applied on the host system's analysis code prior to the search for user defined motion criteria.

Direct Link Interface

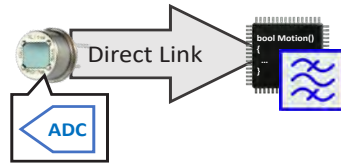

The Direct Link Interface was specially designed for pyroelectric sensors. This one wire interface does not require any external clock since communication speed is controlled by the host system. Either the host system or the sensor can initiate the transmission of data packages. Only one pin is required allowing for extremely compact metal can designs. Since the component drains very little current through the internal ASIC, the disturbance to the heat sensitive pyro-electric material is minimized.

Low-Power DigiPyro

In addition to the digitization stage, the Low Power DigiPyro Series (PYx x5xx and PYx x9xx) also contain an internal band-pass filter as well as a motion detection unit. After power-up, the host system configures the sensor and waits for an interrupt signal by the sensor.

The host system can adjust, via band-pass properties, the threshold which the amplitude has to cross, define the number of threshold crossings, the window time and a dead time to suppress immediate re-triggering.

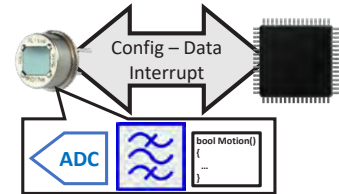

While the PYx x5xx feature lowest possible power consumption with one PIR channel, PYx x9xx Series have two separately configurable PIR motion detection channels. This allows for differential signal analysis and improved signal-to-noise performance.

The optimal choice of parameters depends on the application and the selected lens. To determine those, the raw data can be accessed and analyzed.

The low power DigiPyro series are the optimal choice for battery-operated systems since the host system can be put to sleep while the sensor is continuously monitoring motion of people.



PYD 1788 • PYD 1798

Dual-Element DigiPyro®

This series represents DigiPyro in standard Dual-Element TO-5 housing with different window sizes. Both the PYD 1788 and PYD 1798 models include a built-in temperature reference. The output signals are communicated in one digital bit stream of 2x14 bit, output via a single wire "Direct Link" connection to a suitable host microprocessor.

The DigiPyro PYD 1788 is the economy version with standard size window, while PYD 1798 features a larger filter window offering wider fields-of-view.

Features and Benefits

- TO-5 metal housing
- Digital direct link
- Different window sizes
- Excellent EMI protection

Target applications

- Passive intrusion alarm
- Auto light switch
- Auto lamps

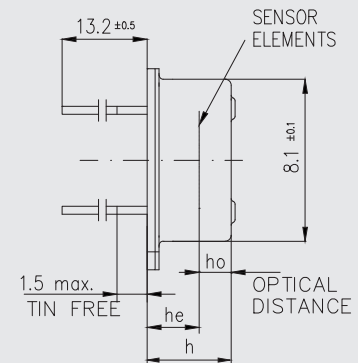
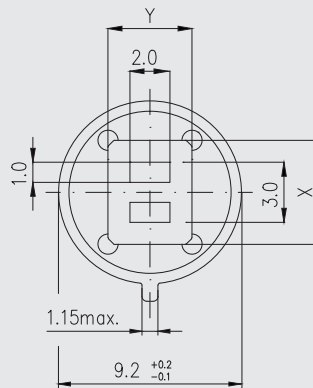
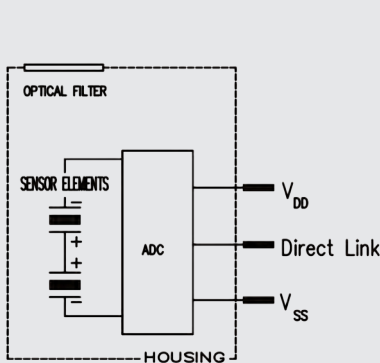

PYD 1788 - PYD 1798					
Parameter	Symbol	PYD 1788	PYD 1798	Unit	Remarks
Responsivity, min.	R_{min}	3.3	3.3	kV/W	$f = 1 \text{ Hz}$
Responsivity, typ.	R	4.0	4.0	kV/W	$f = 1 \text{ Hz}$
Match, max.	M_{max}	10	10	%	
Noise, max.	N_{max}	78	78	μV_{pp}	0.4...10Hz/20°C
Noise, typ.	N	20	20	μV_{pp}	0.4...10Hz/20°C
Operating Voltage		1.8...3.6	1.8...3.6	V	
Supply Current	I_{DDmax}	7	7	μA	$V_{DD} = 3.3V$, no load
Field of View, horizontal	FoV	100	120	°	unobstructed, typ.
Field of View, vertical		90	120	°	unobstructed, typ.
Filter Size	XY	4.6 / 3.4	5.2 / 4.2	mm	
ADC Data					
Resolution		14	14	bit	typ.
Sensitivity		6.5	6.5	$\mu V/count$	typ.
Offset		8192	8192	bitcount	typ.
Optical Element Location	he/ho	3.1/0.7	3.1/0.7	mm	ho=optical
Housing height	h	4.2	4.2	mm	

PYD 1794 • PYD 2792

Dual-Element DigiPyro®

PYD 1794 DigiPyro represents the low-profile TO-39 housing version of standard DigiPyro. The output signal includes an internal temperature reference diode and is communicated in one digital bit stream of 2x14 bit, output via a single wire "Direct Link" connection to a suitable host microprocessor.

The DigiPyro PYD 2792 represents the new SMD version of this design, equipped with the standard Dual Element configuration. It is provided in Excelitas' new 5x7 low profile SMD housing.

Features and Benefits

- TO-39 & SMD housing options
- Digital direct link
- Excellent EMI protection
- Suited for passive intrusion alarm and all types of motion-activated devices

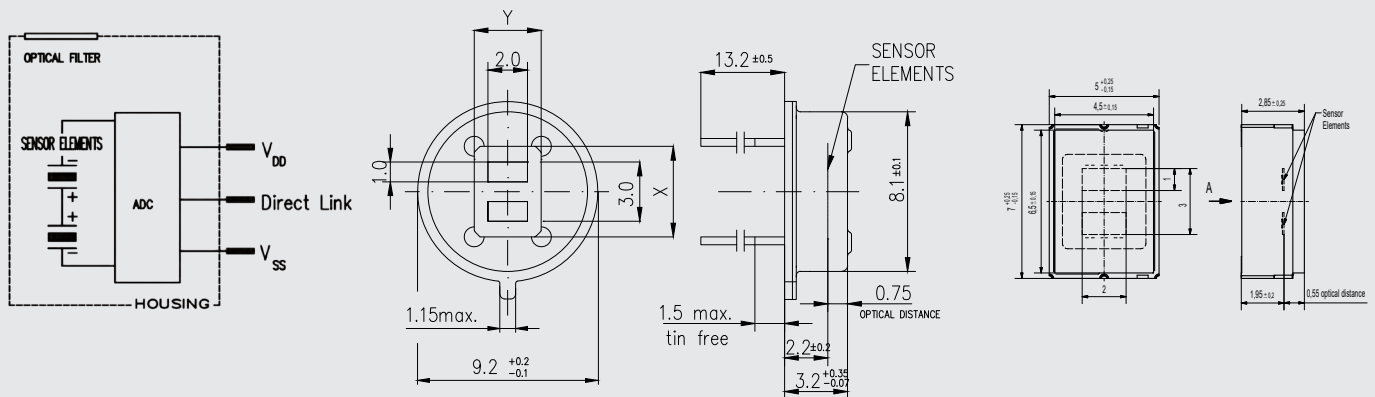

PYD 1794 - PYD 2792

Parameter	Symbol	PYD 1794	PYD 2792	Unit	Remarks
Responsivity, min.	R_{min}	3.3	3	kV/W	$f = 1$ Hz
Responsivity, typ.	R	4.0	3.7	kV/W	$f = 1$ Hz
Match, max.	M_{max}	10	10	%	
Noise, max.	N_{max}	78	90	μV_{pp}	0.4...10Hz/20°C
Noise, typ.	N	20	30	μV_{pp}	0.4...10Hz/20°C
Operating Voltage		1.8...3.6	1.8...3.6	V	
Supply Current	I_{DDmax}	7	7	μA	$V_{DD} = 3.3V$, no load
Field of View, horizontal	FoV	115	147	°	unobstructed, typ.
Field of View, vertical		115	130	°	unobstructed, typ.
Filter Size	X/Y	5.2 / 4.2	5.5 / 3.7	mm	
ADC Data					
Resolution		14	14	bit	typ.
Sensitivity		6.5	6.5	$\mu V/count$	typ.
Offset		8192	8192	bitcount	typ.

PYD 1588 • PYD 1598 • PYD 2592

Dual-Element, Low-Power DigiPyro®

This series is designed with the utmost features of a digital Dual Element Pyro. In TO-5 housing this family is offered with two different window sizes. With its significant reduction of current requirements, this family provides wide range of operation voltage from 1.8V to 3.3V supply at a low current consumption in all operation modes.

The internal electronic circuitry of PYD 1588 and PYD1598 enable the user to select and set individual functions. The output signals are communicated in one digital bit stream of 14 bit via a single wire "Direct Link" connection to a suitable host microprocessor. A similar single wire connection with separate input pin allows the settings of functional parameters such as sensitivity, bandpass selection, pulse count and wake up function. This Pyro provides the full functionality of a complete PIR sensing device when all following circuitry is in sleep mode.

The DigiPyro PYD 1588 is provided with standard size window, while PYD 1598 with its larger filter window offers better White-Light-Immunity (WLI) performance and Field of View.

The DigiPyro PYD 2592 represents the new SMD version of this design, equipped with the standard Dual Element configuration. It is provided in Excelitas' new 5x7 low profile SMD housing. (Refer to SMD package drawing on page 16.)



Features and Benefits

- Wake up/Sleep operation
- Sensitivity setting
- Bandpass selection
- Window time
- Digital Direct Link
- Ideal for battery operated devices

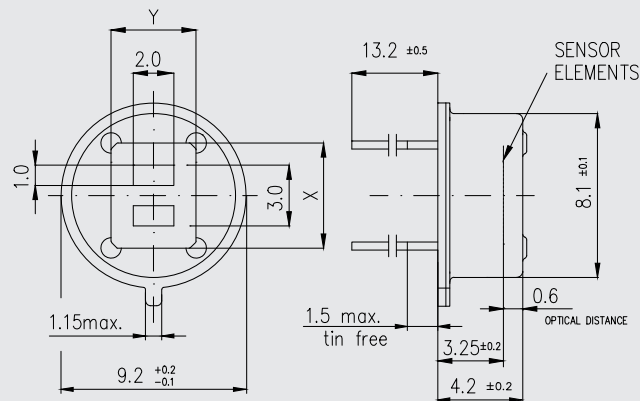
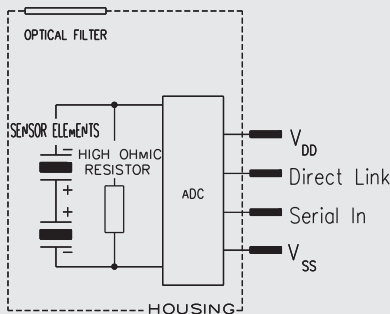

PYD 1588 - PYD 1598 - PYD 2592

Parameter	Symbol	PYD 1588	PYD 1598	PYD 2592	Unit	Remarks
Responsivity, min.	R_{min}	3.3	3.3	3.0	kV/W	f = 1 Hz
Responsivity, typ.	R	4.0	4.0	3.7	kV/W	f = 1 Hz
Match, max.	M_{max}	10	10	10	%	
Noise, max.	N_{max}	78	78	90	μV_{pp}	0.4...10Hz/20°C
Noise, typ.	N	20	20	30	μV_{pp}	0.4...10Hz/20°C
Operating Voltage		1.8...3.6	1.8...3.6	1.8...3.6	V	
Supply Current	I_{DDmax}	3.5	3.5	3.5	μA	$V_{DD} = 3.3V$, no load
Field of View, horizontal	FoV	115	130	147	°	unobstructed, typ.
Field of View, vertical		107	130	130	°	unobstructed, typ.
Filter Size	X/Y	4.6 / 3.4	5.2 / 4.2	5.5 / 3.7	mm	
ADC Data						
Resolution		14	14	14	bit	typ.
Sensitivity		6.5	6.5	6.5	$\mu V/count$	typ.
Offset		8000	8000	8000	bitcount	typ.

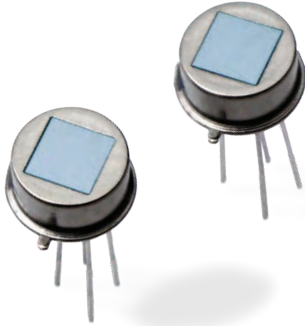

PYQ 1548

Quad-Element Low Power DigiPyro®

This Quad-Element DigiPyro configures all four elements combined to one output with exceptional energy-efficiency. The user selects and sets individual functions. A single-wire connection with separate input pin allows setting of sensitivity, bandpass selection, pulse count and wake up. This provides full functionality of a complete PIR sensing device when all following circuitry is in sleep mode.

PYQ 1748

Quad-Element DigiPyro®

This DigiPyro provides economical Quad configuration with all four elements combined to one common output. This enables ceiling-mount applications when applied with suitable lens optics. TO-5 housing is provided with rectangular window to accommodate wider field-of-view. Standard geometrical element layout offers equal distance and spacing with cross polarity.

Features and Benefits

- TO-5 metal housing
- Equal element spacing
- Digital output via direct link
- Designed for ceiling-mount applications

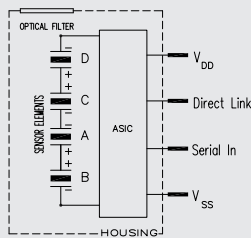

PYQ 1548 Electrical

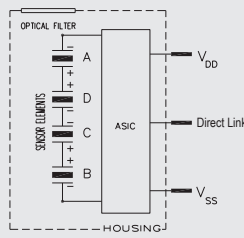

PYQ 1748 Electrical

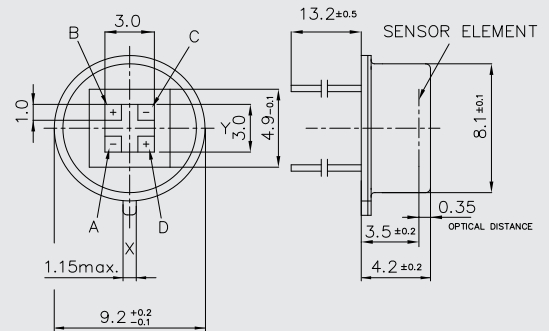

PYQ 1548 Housing and PYQ 1748 Housing

PYQ 1548 - PYQ 1748

Parameter	Symbol	PYQ 1748	PYQ 1548	Unit	Remarks
Responsivity, min.	R _{min}	5.4	5.4	kV/W	f = 1 Hz
Responsivity, typ.	R	6.5	6.5	kV/W	f = 1 Hz
Match, max.	M _{max}	10	10	%	
Noise, max.	N _{max}	140	140	µV _{pp}	0.4...10Hz/20°C
Noise, typ.	N	30	30	µV _{pp}	0.4...10Hz/20°C
Operating Voltage		1.8...3.6	1.8...3.6	V	
Supply Current	I _{DDmax}	7	7	µA	V _{DD} = 3.3V, no load
Field of View, horizontal	FoV	148	124	°	unobstructed, typ.
Field of View, vertical		148	124	°	unobstructed, typ.
Filter Size	X/Y	4.9 / 4.9	4.9 / 4.9	mm	
ADC Data					
Resolution		14	15	bit	typ.
Sensitivity		6.5	6.5	µV/count	typ.
Offset		8192	8000	bitcount	typ.



PYQ 2898 • PYQ 5848

Quad-Element DigiPyro®

This Detector family is distinguished by two pairs of sensing elements with digitized signals for each pair. Together with the signal of an internal reference diode, the output via digital link forms a 3x14 bit stream. As to the spacing of the sensing elements, various designs are available. The TO-5 housing is provided with suitable window size to accommodate the field-of-view of the element configuration.

Features and Benefits

- TO-5 metal housing
- Dual-channel output
- Square / rectangular window
- Different element configuration options
- Suitable for wall and ceiling mount applications

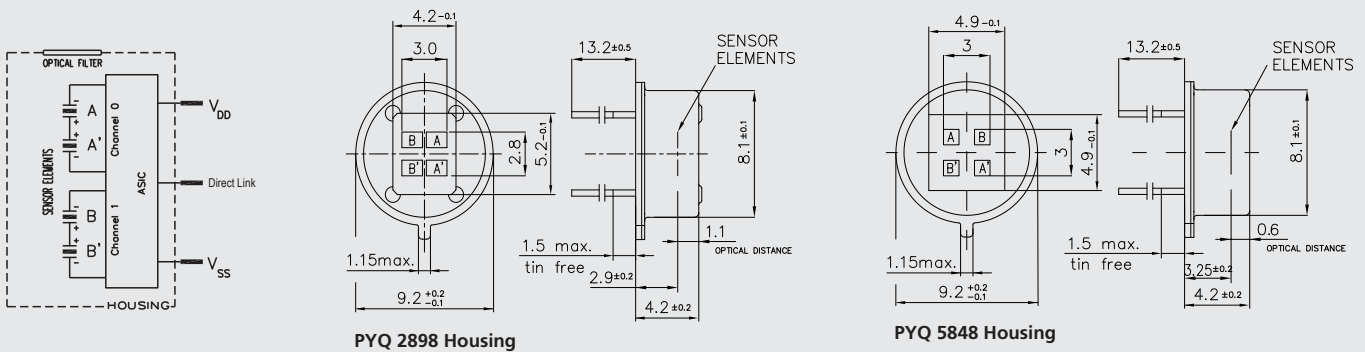

PYQ 2898 - PYQ 5848						
Parameter	Symbol	PYQ 2898	PYQ 5848	Unit	Remarks	
Responsivity, min.	R _{min}	3.5	6.0	kV/W	f = 1 Hz	
Responsivity, typ.	R	4.5	8.0	kV/W	f = 1 Hz	
Match, max.	M _{max}	10	10	%		
Noise, max.	N _{max}	80	100	μV _{pp}	0.4...10Hz/20°C	
Noise, typ.	N	30	40	μV _{pp}	0.4...10Hz/20°C	
Operating Voltage		2.7...3.6	2.7...3.6	V		
Supply Current	I _{DDmax}	15	15	μA	V _{DD} = 3.3V, no load	
Field of View, horizontal	FoV	100	124	°	unobstructed, typ.	
Field of View, vertical		60	124	°	unobstructed, typ.	
Filter Size	X/Y	5.2 / 4.2	4.9 / 4.9	mm		
ADC Data						
Resolution		14	14	bit	typ.	
Sensitivity		6.5	6.5	μV/count	typ.	
Offset		8192	8192	bitcount	typ.	

The Thermoelectric Effect

The thermoelectric effect (or Seebeck-effect) is known as reverse to the Peltier-effect. By applying a temperature difference to two junctions of two dissimilar materials A and B, a voltage U , which is proportional to the temperature difference is observed.

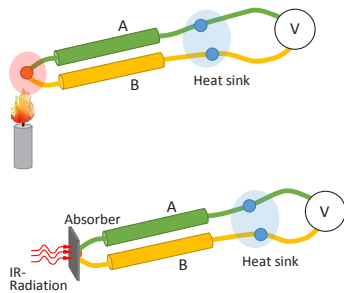

Fig 7: The Seebeck effect

Detector Design

Leopoldo Nobili (1784 - 1835) first used the thermoelectric effect for IR radiation measurement using a “pile” of Bismuth and Antimony contacts. The measure of this effect is called the thermoelectricor Seebeck-coefficient.

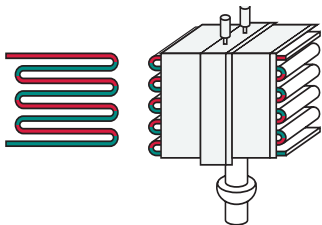

Fig 8: Nobili's Thermopile

For most conducting materials this coefficient is rather low, only few semiconductors possess rather high coefficients. Since the voltage of a single thermoelectric cell is very low, lots of such cells arranged in a series connection achieve a larger signal, making a “pile” of thermo-elements.

Excelitas Thermopile Design

Our thermopile sensors are based on silicon micromachining technology. The central part of a silicon chip is removed leaving only a $1\mu\text{m}$ thin layer (membrane) of $\text{SiO}_2/\text{Si}_3\text{N}_4$, which has low thermal conductivity. Onto this membrane thin conductors of two different thermoelectric materials (to form thermocouples) are deposited.

Both conductors have junctions alternatively in the center of the membrane (hot junctions) and on the bulky part of the silicon substrate (cold junctions). A special IR-absorption layer covers the hot junctions forming the sensors sensitive area.

When exposed to infrared radiation, the absorbed energy leads to a temperature difference between “hot” and “cold” contacts. According to the thermoelectric coefficient of the thermocouples a signal voltage is generated.

The Thermopile Construction

The sensor chip is mounted in good thermal contact into a housing with infrared filter sealing the sensor chip from the environment. The infrared filter serves as window with spectral properties. Excelitas's product portfolio includes detectors of various housings as well as integrated sensors which include temperature compensation and calibration to specified measurement ranges. We further provide unique construction models with improved thermal shock performance, referred to as ISO-thermal sensor types.

Thermopile Detectors do not require mechanical chopper to sense infrared, they offer simple solutions to infrared measurements.

Thermopile Characteristics

The most important properties of the Thermopile Sensor are its responsivity, noise, field-of-view and response time.

Responsivity

The responsivity shows low-pass characteristics with a cut off at approximately 30 Hz. Responsivity is measured in Volt per Watt by means of a defined black body radiator. Responsivity data is usually cited with respect to the active detector area, given without the infrared filter. The data shows responsivity tested at 1 Hz electrical frequency.

Noise

The noise of the detector is dominated by the Johnson noise due to the resistance of the thermopile. Noise is given as RMS value in $\text{nV}/\sqrt{\text{Hz}}$.

Sensitivity

The data tables do also mention sensitivity, as a characteristic output voltage versus target temperature at 25°C environment temperature. The data are given with standard IR filter and specified at 25°C ambient temperature and different object / blackbody temperatures, e.g. 40°C $S(25/40)$ and 100°C $S(25/100)$. Sensitivity is dependent upon the field-of-view of the detector construction. An example can be seen below for selected thermopile detector series.

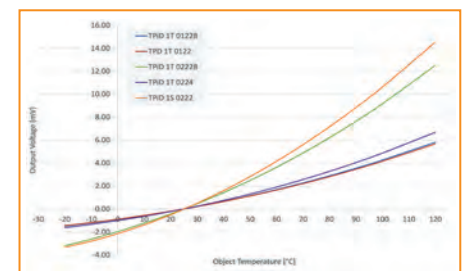

Fig 9: Sensitivity curves

Ambient Temperature Reference

As temperature reference the thermopile detectors include a thermistor which senses the internal temperature.

For exact measurements, the temperature of the detector housing (cold thermopile contacts) must be known. A 100 kOhm thermistor inside the detector housing serves as the ambient temperature reference.

The dependence of the resistance on temperature can be approximated by the following equation:

$$R_T = R_R \cdot e^{B \cdot \left(\frac{1}{T} - \frac{1}{T_R} \right)}$$

RT	NTC resistance in Ω at temperature T in K
RR	NTC resistance in Ω at rated temperature TR in K
T	Temperature in K
TR	Rated temperature in K
B	B value, material-specific constant of NTC thermistor
e	Euler number (e = 2.71828)

The actual characteristic of an NTC thermistor can be roughly described by the exponential relation. This approach, however, is only suitable for describing a restricted range around the rated temperature or resistance with sufficient accuracy. For practical applications, a more precise description of the real R/T curve is required. Either more complicated approaches (e.g. the Steinhart-Hart equation) are used or the resistance / temperature relation is given in tabulated form.

The Field-of-View

The most common use of thermopile detectors is non-contact temperature sensing. All target points within

the field-of-view will contribute to the measurement signal. To meet requirements of different applications, Excelitas offers a broad range of sensors with different windows and optics. The field-of-view data describes the dependence of signal from incident angles.

DigiPile® Sensors

Excelitas DigiPile was the first digital output Thermopile Sensor to reach the market, enabling direct connection to a microprocessor and streamlining integration. The Excelitas DigiPile line of Thermal IR Detectors are designed specifically for non-contact temperature measurement and are available in traditional TO-46 and TO-5 metal housings, as well as our SMD (Surface Mount Device) models in an ultra-compact, ceramic-type package.

Our DigiPile sensors feature a highly sensitive ADC input stage, which does not require further amplification, enabling easier integration into customer applications. The DigiPile sensors are available in an ISO-thermal package suited for applications such as ear thermometry.

CaliPile® Sensors

The CaliPile sensors represent the latest innovation in IR sensing. The only one of its kind, the CaliPile is a multifunction thermal infrared sensor. In addition to traditional non-contact temperature measurement capabilities, CaliPile sensors offer motion detection and presence monitoring across short to medium ranges. To enable these individual functions, the internal circuit combines data storage with calibration data and a number of digital filters. With selectable frequency filters and levels, the CaliPile enables users to set the product into different operating modes. The CaliPile receives calibration data to support temperature-related processing and output. Depending on the model, the sensor is calibrated for an object temperature range up to

200°C. Customers can use a maximum temperature setting to set the trigger level as the interrupt function will alert users when the level is exceeded.

Applications for the CaliPile Series include short-range presence detection with no additional lens requirements, non-contact temperature measurement and overheating protection. It is ideally suited for IoT and smart-home products, lighting and printer sensing, and general industry thermal IR detection.

Thermopile Modules

With its range of Thermopile Modules, Excelitas offers plug-and-play function and streamlined systems integration. The TPMI® modules include the thermopile sensor mounted on a PCB with a connector. The PCB caters to features such as voltage regulation and a noise-reduction filter.

The ISO-thermal module includes integrated temperature compensation for a defined temperature environment and the calibration to a certain object temperature range. TPMI Modules are offered as programmed per customer request, in addition to standard versions. For requirements of defined spot sizes, Excelitas offers sensors with a field-of-view defined by optical apertures, internal lenses or external mirror optics.

Applications for Thermopile Sensors

Thermopile Sensors have been designed for non-contact temperature measurement. The signal of the sensor follows the radiation energy receipt by the sensor. This enables measuring surface temperatures without contact.

For industrial process controls, thermopile sensors are used to remotely monitor temperature as overheating protection. Thermopiles are also suited for domestic appliances such as food monitoring during defrosting, warming-up or cooking. Typical medical applications are body and skin temperature measurement, e.g. forehead and ear thermometry.

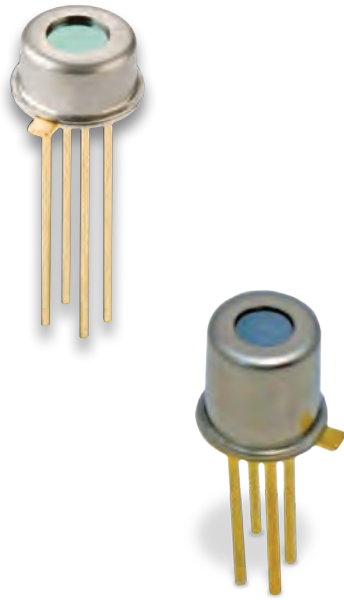

TPD 1T 0122

Miniature Thermopile Detector

This Thermopile Detector in TO-46 housing features a miniature housing including a sensitive chip with small optical window. The window is optically coated in the IR band 5-14 μ m. The housing includes a thermistor for ambient temperature compensation.

TPD 1T 0122 L3.0

Miniature Thermopile Detector with lens

This Thermopile Detector in miniature TO-46 housing includes a focusing lens built into the smallest TO housing based thermopile detector. It includes a specially designed sensing chip and a standard internal Thermistor as temperature reference for temperature compensation. The built-in lens provides the narrow field-of-view for long-range contactless temperature measuring applications.

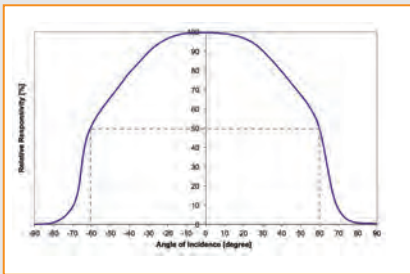

FoV TPD 1T 0122

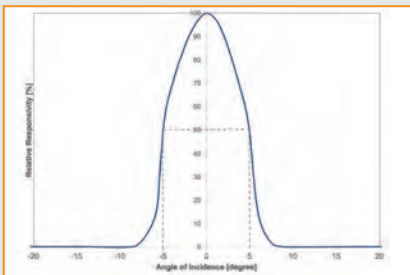

FoV TPD 1T 0122 L3.0

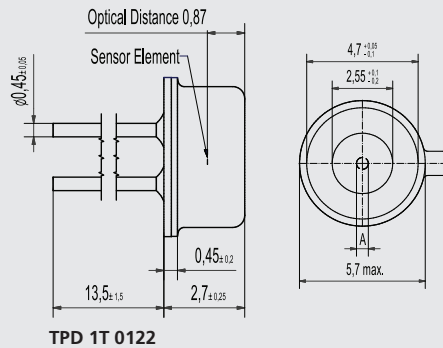

TPD 1T 0122

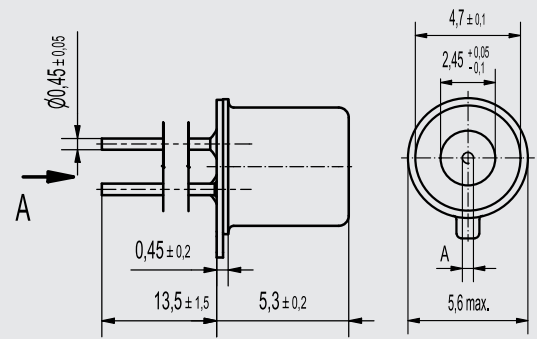

TPD 1T 0122 L3.0

TPD 1T 0122 L3.0 - TPD 1T 0122

Parameter	Symbol	TPD 1T 0122 L3.0	TPD 1T 0122	Unit	Remarks
Sensitive Area	A	Ø 0.5	Ø 0.5	mm	Absorber Area
Thermopile Resistance	R _{TP}	85...135	85...135	kΩ	25°C
Responsivity	R	77	77	V/W	500°K / 1Hz / Without IR-filter
Sensitivity (T _{det} 25 °C / T _{obj} 40 °C)	S ₄₀	18.6	43	μV/K	
Sensitivity (T _{det} 25 °C / T _{obj} 100 °C)	S ₁₀₀	25	56	μV/K	
Time Constant	t	15	15	ms	
Noise Voltage	V _n	42	42	nV/√Hz	25°C
Specific Detectivity	D*	0.8	0.8	10° cm√Hz/W	25°C
Temp. Coefficient of Resistance	TC _{RTP}	0,03	0,03	%/K	
Temp. Coefficient of Responsivity	TC _R	-0,05	-0,05	%/K	
Field of view	FoV	10	120	Degrees	at 50% intensity points
Thermistor resistance (25°C)	R ₂₅	100	100	kΩ	25 °C
Thermistor BETA-value	β	3964	3964	K	defined at 25 °C / 100 °C

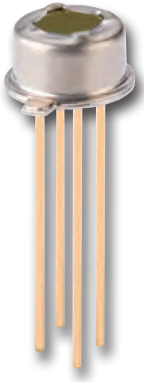

TPD 1T 0223

Miniature Thermopile Detector

Thermopile Detector in miniature TO housing for general-purpose Detectors in 4.7 mm diameter TO-46 type housings, feature a specially-designed element configuration. The window is available as standard infrared or optional with narrow band-pass for gas-sensing applications. With the narrowband filter a square window is provided.

TPD 1T 0223 provides the small absorbing area, and is equipped as standard with an internal thermistor as temperature reference for ambient temperature compensation.

Features and Benefits

- Small housing
- Square window
- Filter options

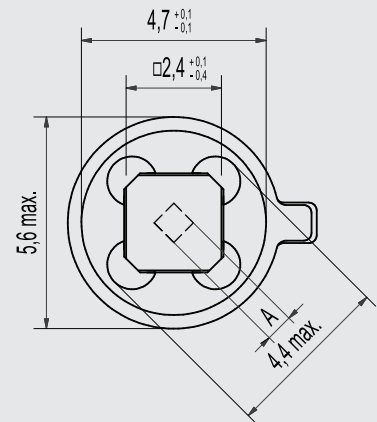
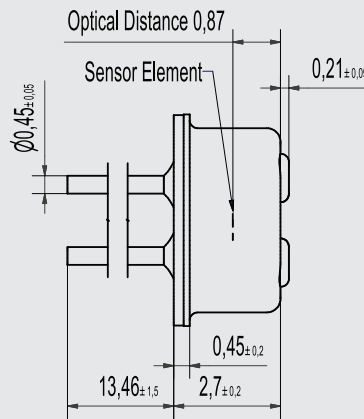
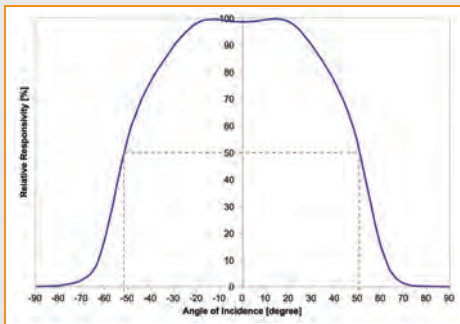

TPD 1T 0223				
Parameter	Symbol	TPD 1T 0223	Unit	Remarks
Sensitive Area	A	0.7 x 0.7	mm	Absorber Area
Thermopile Resistance	R _{TP}	50...100	kΩ	25°C
Responsivity	R	45	V/W	500°K / 1Hz / Without IR-filter
Sensitivity (T _{det} 25 °C / T _{obj} 40 °C)	S ₄₀	88	μV/K	
Sensitivity (T _{det} 25 °C / T _{obj} 100 °C)	S ₁₀₀	116	μV/K	
Time Constant	t	22	ms	
Noise Voltage	V _n	35	nV/√Hz	25°C
Specific Detectivity	D*	0.9	10° cm√Hz/W	25°C
Temp. Coefficient of Resistance	TC _{RTP}	0,03	%/K	
Temp. Coefficient of Responsivity	TC _R	-0,05	%/K	
Field of view	FoV	104	Degrees	at 50% intensity points
Thermistor resistance (25°C)	R ₂₅	100	kΩ	25 °C
Thermistor BETA-value	β	3964	K	defined at 25 °C / 100 °C

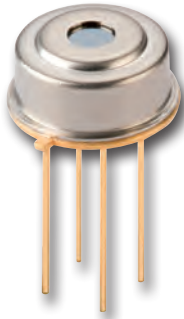

TPiD 1T 0224 • TPiD 1T 0624

Thermopile Detectors

This Thermopile Detector in TO-99 housing offers a sensitive chip placed into the housing with aperture-type, small optical window. This family provides the ISOthermal performance for improved thermal shock resistance. Excelitas offers a range of ISOthermal Thermopile Detectors in TO-99 type housings. Our patented ISOthermal feature provides improved system performance when subjected to thermal shock conditions.

Both types are provided with round window, which also serves as aperture. All feature a specially designed element configuration, each one with different sized absorbing areas. TPiD 1T 0224 provides the smallest absorbing area, TPiD 1T 0624 offers the largest absorbing sensor area and highest sensitivity. All types are equipped as standard with internal thermistor as temperature reference for ambient temperature compensation.

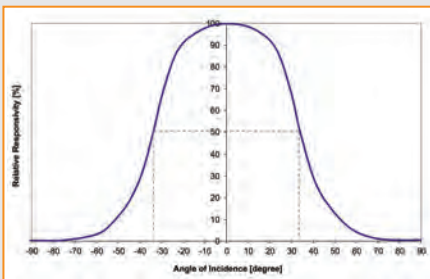

FoV TPiD 1T 0224

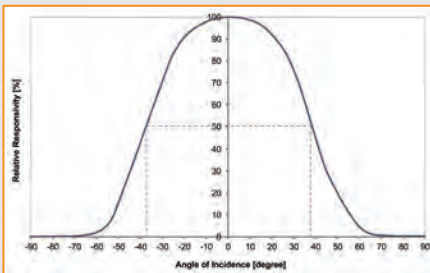

FoV TPiD 1T 0624

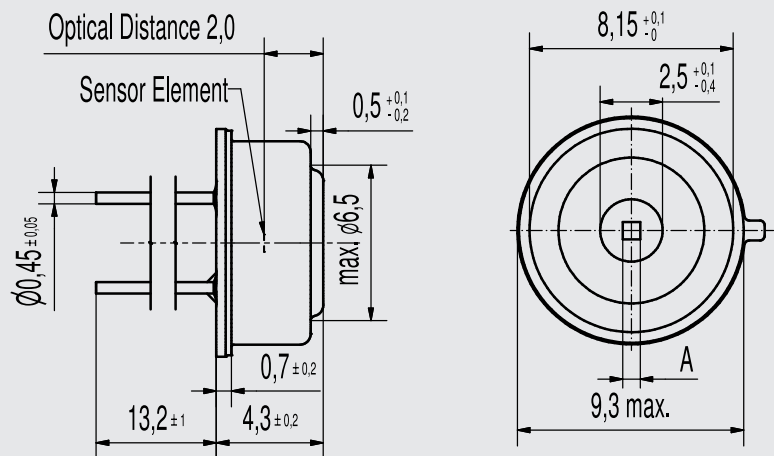

TPiD 1T 0224 - TPiD 1T 0624

Parameter	Symbol	TPiD 1T 0224	TPiD 1T 0624	Unit	Remarks
Sensitive Area	A	0.7 x 0.7	1.2 x 1.2	mm	Absorber Area
Thermopile Resistance	R _{TP}	50...100	50...110	kΩ	25°C
Responsivity	R	45	33	V/W	500°K / 1Hz / Without IR-filter
Sensitivity (Tdet 25 °C / Tobj 40 °C)	S ₄₀	50	92	μV/K	
Sensitivity (Tdet 25 °C / Tobj 100 °C)	S ₁₀₀	65	120	μV/K	
Time Constant	t	22	27	ms	
Noise Voltage	V _n	35	36	nV/√Hz	25°C
Specific Detectivity	D*	0.9	1.1	10 ⁸ cm ² /Hz/W	25°C
Temp. Coefficient of Resistance	TC _{RTP}	0,03	0,03	%/K	
Temp. Coefficient of Responsivity	TC _R	-0,05	-0,05	%/K	
Field of view	FoV	70	76	Degrees	at 50% intensity points
Thermistor resistance (25°C)	R ₂₅	100	100	kΩ	25°C
Thermistor BETA-value	β	3964	3964	K	defined at 25°C / 100°C

TPD 1T 0226 IRA • TPiD 1T 0226 L5.5

Thermopile Detector with integrated Optics

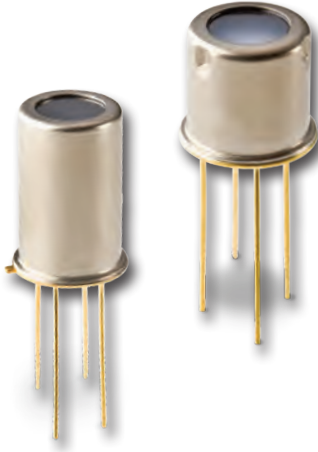

This Series of Thermopile Detectors with integrated optics offer two different alternatives: IRA type with high metal can which includes an integrated reflector for collecting the radiation receipt, or the L5.5 type with integral lens for focusing radiation towards the sensitive chip.

The IRA type thermopile is specially suited with an internal reflector that reduces the field-of-view and offers a smaller measurement "target" spot than conventional detectors without optics. Due to the reflector, the housing size is taller than other types, although the housing has the same diameter as a standard TO-5 housing.

The TPiD 1T 0226 L5.5 provides the ISOthermal performance feature and integral optics. A built-in internal lens provides a field-of-view slightly sharper than the IRA type.

All versions are equipped as standard with an internal thermistor as temperature reference for ambient temperature compensation.

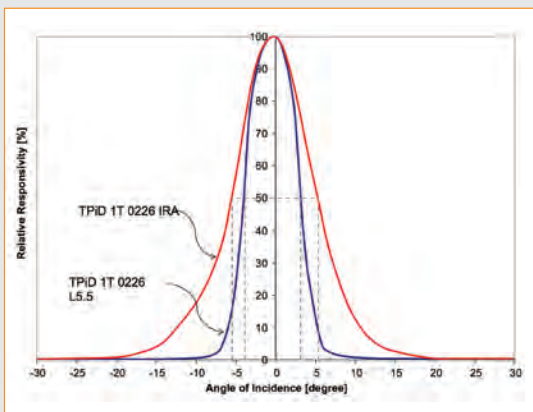

FoV TPD 1T 0226 IRA - TPiD 1T 0226 L5.5 Combined

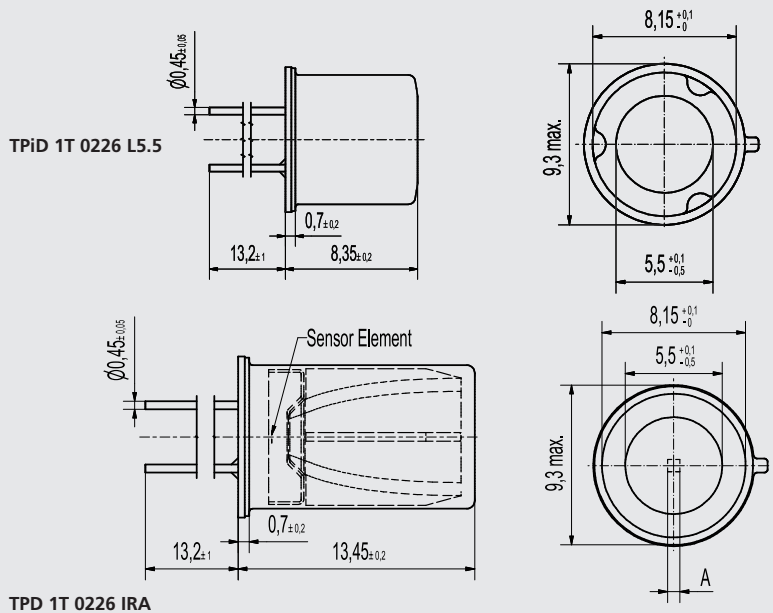

TPD 1T 0226 IRA - TPiD 1T 0226 L5.5

Parameter	Symbol	TPiD 1T 0226 L5.5	TPD 1T 0226 IRA	Unit	Remarks
Sensitive Area	A	0.7 x 0.7	0.7 x 0.7	mm	Absorber Area
Thermopile Resistance	R _{TP}	50...100	50...100	kΩ	25°C
Responsivity	R	45	45	V/W	500°K / 1Hz / Without IR-filter
Sensitivity (T _{det} 25 °C / Tobj 40 °C)	S ₄₀	20	62	μV/K	
Sensitivity (T _{det} 25 °C / Tobj 100 °C)	S ₁₀₀	27	82	μV/K	
Time Constant	t	22	22	ms	
Noise Voltage	V _n	35	35	nV/√Hz	25°C
Specific Detectivity	D*	0.9	0.9	10 ⁸ cm ² /Hz/W	25°C
Temp. Coefficient of Resistance	TC _{RTP}	0,03	0,03	%/K	
Temp. Coefficient of Responsivity	TC _R	-0,05	-0,05	%/K	
Field of view	FoV	7	15	Degrees	at 50% intensity points
Thermistor resistance (25°C)	R ₂₅	100	100	kΩ	25 °C
Thermistor BETA-value	β	3964	3964	K	defined at 25 °C / 100 °C

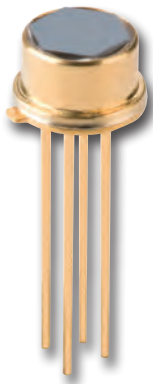

TPiD 1T 0122B • TPiD 1T 0222B • TPiD 1T 0622B

ISOthermal Thermopile Detector

This Excelitas Thermopile Detector with ISOthermal design features a special housing concept matched with a sensitive chip and small optical window. As the industry standard for ear thermometry applications, these Thermopile Detectors are referenced as ISOthermal detectors. The patented designs provide superior performance under thermal shock conditions and thereby are best suited for the tympanon ear thermometry.

The range comprises TPiD 1T 0122B as the low cost version, whereas the versions TPiD 1T 0222B and TPiD 1T 0622B provide higher signal by high sensitive element designs and larger element area. The physical dimensions of the ISO thermal sensors are equivalent to our TO-46 sensor housings and include a special aperture. All types are equipped with an internal Thermistor as temperature reference for ambient temperature compensation.

Features and Benefits

- Patented ISOthermal design
- TO-46 type housing

Target applications

- Ear thermometry

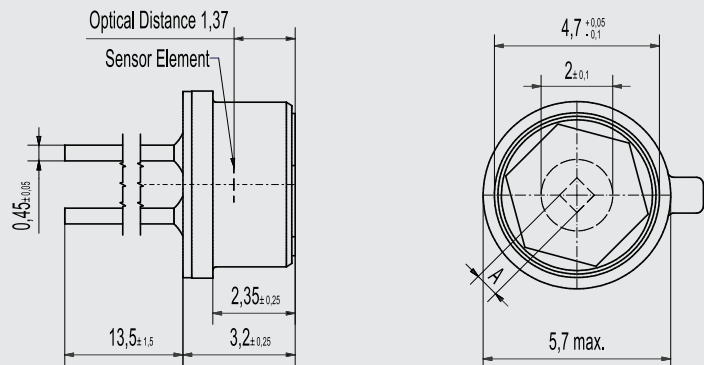
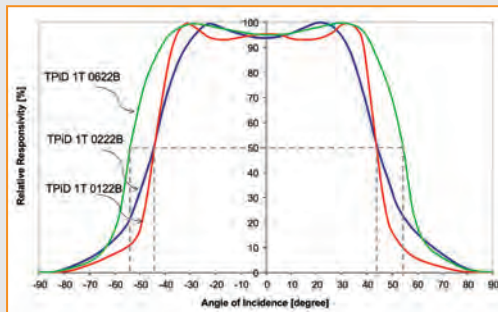

TPiD 1T 0122B, TPiD 1T 0222B, TPiD 1T 0622B

Parameter	Symbol	TPiD 1T 0122B	TPiD 1T 0222B	TPiD 1T 0622B	Unit	Remarks
Sensitive Area	A	∅ 0.5	0.7 x 0.7	1.2 x 1.2	mm	Absorber Area
Thermopile Resistance	R _{TP}	85...135	50...100	50...110	kΩ	25°C
Responsivity	R	92	60	40	V/W	500°K/ 1Hz/ Without IR-filter
Sensitivity (T _{det} 25 °C / T _{obj} 40 °C)	S ₄₀	44	95	150	μV/K	
Sensitivity (T _{det} 25 °C / T _{obj} 100 °C)	S ₁₀₀	58	125	200	μV/K	
Time Constant	t	15	22	27	ms	
Noise Voltage	V _n	42	35	36	nV/√Hz	25°C
Specific Detectivity	D*	1.0	1.2	1.3	10 ⁸ cm ² /Hz/W	25°C
Temp. Coefficient of Resistance	TC _{RTP}	0,03	0,03	0,03	%/K	
Temp. Coefficient of Responsivity	TC _R	-0,05	-0,05	-0,05	%/K	
Field of view	FoV	90	90	110	Degrees	at 50% intensity points
Thermistor resistance (25°C)	R ₂₅	100	100	100	kΩ	25 °C
Thermistor BETA-value	β	3964	3964	4092	K	defined at 25 °C / 100 °C

TPiD 1S 0121 • TPiD 1S 0222

Thermopile Detectors, SMD

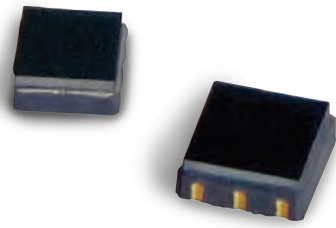

Thermopile Detectors in SMD housings offer two different sensitive chips which require different SMD housing sizes to accommodate either smaller form factor or higher sensitivity performance.

This enables standard SMT assembly processes and affords smaller host system designs. The SMD versions feature the unique ISOthermal performance for applications that are subjected to thermal shock conditions.

The TPiD 1S 0121 is the smallest SMD version we offer, whereas the TPiD 1S 0222 provides an element with higher sensitivity. Again, these detectors are equipped with an internal thermistor as temperature reference for Thermopile temperature compensation. All SMD parts are supplied in volume in tape & reel packaging.

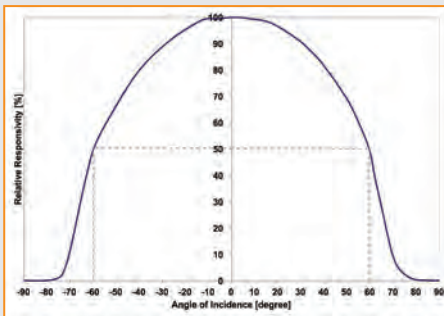

FoV TPiD 1S 0121 - TPiD 1S 0222 Combined

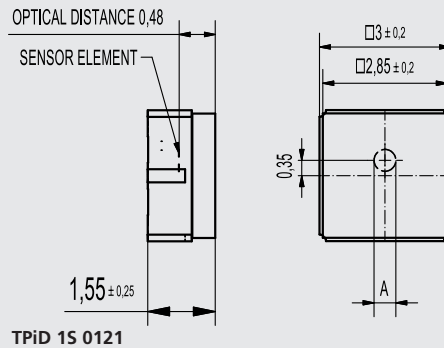

TPiD 1S 0121

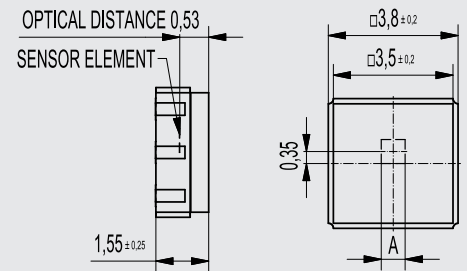

TPiD 1S 0222

TPiD 1S 0121 - TPiD 1S 0222

Parameter	Symbol	TPiD 1S 0121	TPiD 1S 0222	Unit	Remarks
Sensitive Area	A	Ø 0.5	0.7 x 0.7	mm	Absorber Area
Thermopile Resistance	R _{TP}	85...135	50...100	kΩ	25°C
Responsivity	R	77	45	V/W	500°/ 1Hz/ Without IR-filter
Sensitivity (T _{det} 25 °C / T _{obj} 40 °C)	S ₄₀	42	107	µV/K	
Sensitivity (T _{det} 25 °C / T _{obj} 100 °C)	S ₁₀₀	56	142	µV/K	
Time Constant	t	15	22	ms	
Noise Voltage	V _n	42	35	nV/√Hz	25°C
Specific Detectivity	D*	0.8	1.2	10° cm√Hz/W	25°C
Temp. Coefficient of Resistance	TC _{RTP}	0,03	0,03	%/K	
Temp. Coefficient of Responsivity	TC _R	-0,05	-0,05	%/K	
Field of view	FoV	120	120	Degrees	at 50% intensity points
Thermistor resistance (25°C)	R ₂₅	100	100	kΩ	25 °C
Thermistor BETA-value	β	4092	4092	K	defined at 25 °C / 100 °C

TPiS 1S 1051 • TPiS 1S 1252

DigiPile® Sensors, SMD

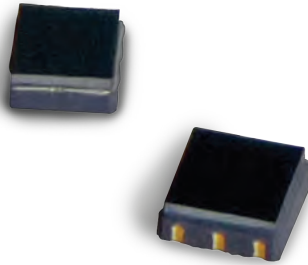

The DigiPile Sensor features a Thermopile sensing chip connected to an internal ADC which provides for amplification and digital conversion. Housed in a specially designed SMD carrier with optical window, the DigiPile offers two different versions of sensing chips.

The SMD type DigiPile provides for a Thermopile with digital 17-bit output. As many other types, this detector is offered with our patented ISOthermal performance. Within the bit stream the thermopile signal is followed by another signal given by an internal temperature reference diode. With the digital output, low interference of electric disturbance is achieved. These features enable optimum designs for a wide range of temperature measurement applications. With TPiS 1S 1051 we provide the smallest housing and smallest thermopile chip available. With TPiS 1S 1252 the housing is slightly larger due to a higher sensitivity thermopile chip to provide enhanced performance.

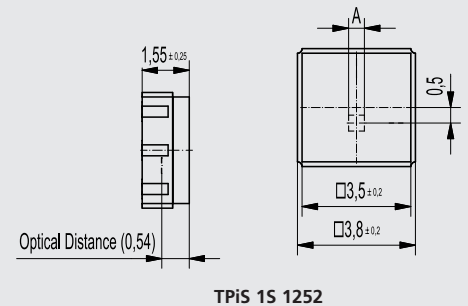
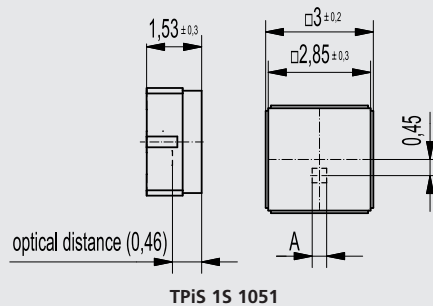
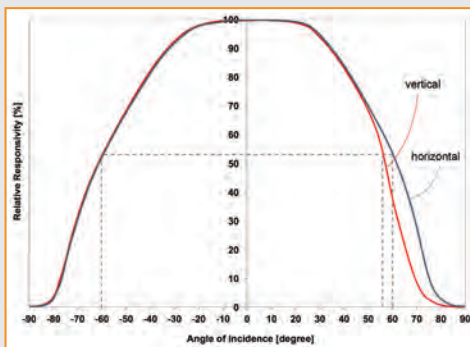

TPiS 1S 1051 - TPiS 1S 1252						
Parameter	Symbol	TPiS 1S 1252	TPiS 1S 1051	Unit	Remarks	
Operating Conditions						
Operating Voltage	V_{DD}	2,4...3,6	2,4...3,6	V		
Supply Current	I_{DD}	max. 15	15 max.	μA	$V_{DD} = 3.3 V$	
Operating Temperature	T_o	-20...70	-20...70	$^{\circ}C$	Parameters may vary from specified values with temperature dependence.	
Storage Temperature	T_s	-40...100	-40...100	$^{\circ}C$		
Thermopile Characteristics						
Sensitive Area	A	0,51 x 0,51	0,4 x 0,4	mm^2	Absorber area	
Sensitivity ($T_{det} 25^{\circ}C / T_{obj} 40^{\circ}C$)	S_{40}	400	210	counts/K		
Sensitivity ($T_{det} 25^{\circ}C / T_{obj} 100^{\circ}C$)	S_{100}	530	280	counts/K		
Noise of TP		8	8	counts	$T_{obj} = 40^{\circ}C, T_{amb} = 25^{\circ}C$	
Time Constant	t	45	15	ms		
Ambient Temperature Sensor Characteristics						
Sensitivity of T_{amb}		90	90	counts/K	Linear for T_{amb} from $0^{\circ}C$ to $90^{\circ}C$	
Count @ $T_{amb} = 25^{\circ}C$		7000...9400	7000...9400	counts	Range	
Optical Characteristics						
Field of View	FoV	120	120 / 116	Degree	At 50% intensity points	
Electrical Characteristics						
ADC Resolution T_{obj}		17	17	Bits	Max Count = 2^{17}	
ADC Resolution T_{amb}		14	14	Bits	Max Count = 2^{14}	
ADC Sensitivity of T_{obj}		0,7...0,9	0,7...0,9	$\mu V/count$		
ADC Offset T_{obj}		64000...65000	64000...65000	counts	Range	

TPiS 1S 1385 • TPiS 1S 0185

CaliPile® Sensor in SMD Housing

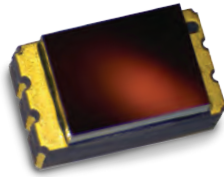

The CaliPile Sensors represent the latest innovation in IR sensing from Excelitas. The only one of its kind, the CaliPile is a multifunction, thermal infrared sensor. In addition to traditional non-contact temperature measurement capabilities, the CaliPile offers motion detection and presence monitoring across short to medium ranges.

The CaliPile thermopile sensing chip is connected to an internal circuitry and housed in tiny SMD housing. The integrated electronics provide digital conversion and further filtering and processing. The TPiS 1S xx85 Sensor is the SMD version of the CaliPile Series providing I2C bus communication and signal output. An additional interrupt may serve as a 'Yes/No' output for the motion, presence and temperature applications. The TPiS 1S 1385 facilitates an extremely compact SMD form factor, suited for medium-distance human presence detection without additional lens requirements. For short-range and low-cost sensor applications, we offer a less sensitive chip with TPiS 1S 0185.

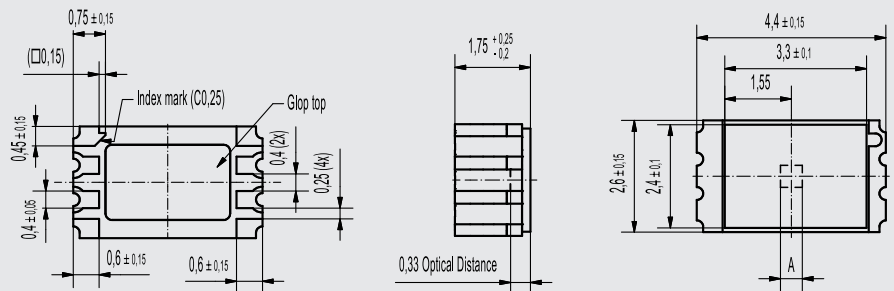
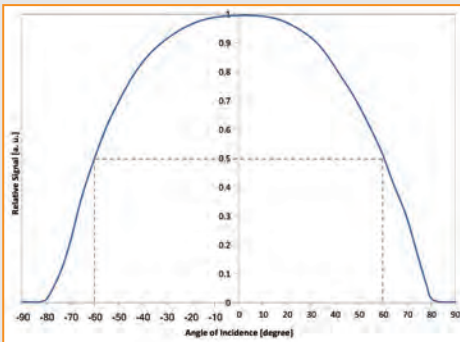

TPiS 1S 1385 - TPiS 1S 0185

Parameter	Symbol	TPiS 1S 1385	TPiS 1S 0185	Unit	Remarks
Operating Conditions					
Operating Voltage	V_{DD}	2,6...3,6	2,6...3,6	V	
Supply Current	I_{DD}	15 max.	15 max.	μA	$V_{DD} = 3.3 V$
Operating Temperature	T_o	-20...85	-20...85	$^{\circ}C$	Parameters may vary from specified values with temperature dependence.
Storage Temperature	T_s	-40...100	-40...100	$^{\circ}C$	
Thermopile Characteristics					
Sensitive Area	A	0,56 x 0,56	$\varnothing 0.5$	mm^2	Absorber area
Sensitivity ($T_{det} 25^{\circ}C / T_{obj} 40^{\circ}C$)	S_{40}	400	75	counts/K	
Noise of TP		8	8	counts	$T_{obj} = 40^{\circ}C, T_{amb} = 25^{\circ}C$
Time Constant	t	30	15	ms	
Ambient Temperature Sensor Characteristics					
Sensitivity of T_{amb}		170	170	counts/K	Linear for T_{amb} from $0^{\circ}C$ to $85^{\circ}C$
Count @ $T_{amb} = 25^{\circ}C$		11000...17000	11000...17000	counts	Range
Optical Characteristics					
Field of View	FoV	120	120	Degree	At 50% intensity points
Electrical Characteristics					
ADC Resolution T_{obj}		17	17	Bits	Max Count = 2^{17}
ADC Resolution T_{amb}		15	15	Bits	Max Count = 2^{15}
ADC Sensitivity of T_{obj}		0,7...0,9	0,7...0,9	$\mu V/count$	
ADC Offset T_{obj}		64000...65000	64000...65000	counts	Range

TPiS 1T 1086 L5.5 • TPiS 1T 0186 L5.5

CaliPile® Sensor TO-5 Housing with Lens



CaliPile Sensors represent the latest innovation in IR sensing from Excelitas. The only one of its kind, the CaliPile is a multifunction, thermal infrared sensor. In addition to traditional non-contact temperature measurement capabilities, the CaliPile offers motion detection and presence monitoring across short to medium ranges.

The CaliPile sensing chip is connected to an internal circuitry within a tall TO-5 housing with built in optical lens. The integrated electronics provide digital conversion and further filtering and processing. The sensor is available as calibrated for temperature ranges of max object temperature 250°C at +/- 3°C for temperature measurement applications working up to 350 / 600°C maximum range. Users may reference the maximum temperature setting as trigger level since the interrupt function will alert users when the level has exceeded.

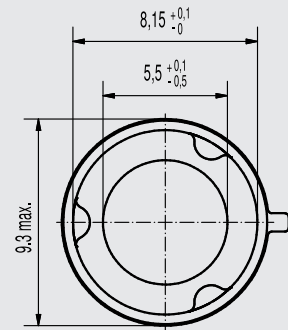
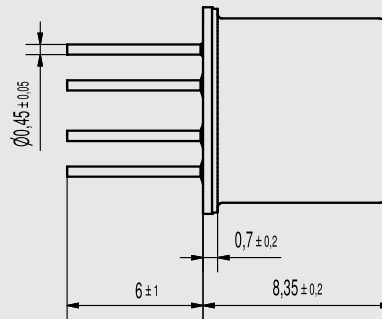
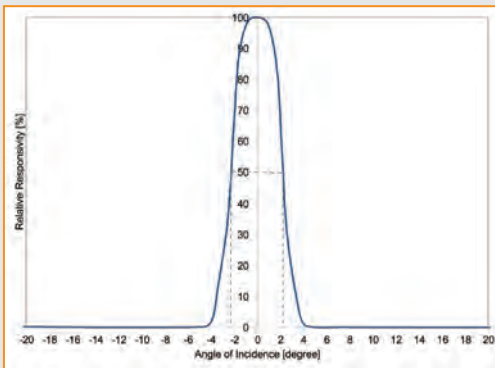

TPiS 1T 1086 L5.5 - TPiS 1T 0186 L5.5

Parameter	Symbol	TPiS 1T 1086 L5.5	TPiS 1T 0186 L5.5	Unit	Remarks
Operating Conditions					
Operating Voltage	V _{DD}	2,6...3,6	2,6...3,6	V	
Supply Current	I _{DD}	15 max.	15 max.	µA	V _{DD} = 3.3 V
Operating Temperature	T _o	-20...85	-20...85	°C	Parameters may vary from specified values with temperature dependence.
Storage Temperature	T _s	-40...100	-40...100	°C	
Thermopile Characteristics					
Sensitive Area	A	0,41 x 0,41	Ø 0.5	mm ²	Absorber area
Sensitivity (T _{det} 25 °C / T _{obj} 40 °C)	S ₄₀	30	10	counts/K	
Noise of TP	S ₁₀₀	8	8	counts	T _{obj} = 40°C, T _{amb} = 25°C
Time Constant		15	15	ms	
Ambient Temperature Sensor Characteristics					
Sensitivity of T _{amb}	t	170	170	counts/K	Linear for T _{amb} from 0°C to 85°C
Count @ T _{amb} = 25°C		11000...17000	11000...17000	counts	Range
Optical Characteristics					
Field of View	FoV	5	5	Degree	At 50% intensity points
Electrical Characteristics					
ADC Resolution T _{obj}		17	17	Bits	Max Count = 2 ¹⁷
ADC Resolution T _{amb}		15	15	Bits	Max Count = 2 ¹⁵
ADC Sensitivity of T _{obj}		0,7...0,9	0,7...0,9	µV/count	
ADC Offset T _{obj}		64000...65000	64000...65000	counts	Range

TPiS 1T 1084

CaliPile® Sensor in TO-39 Housing with Window

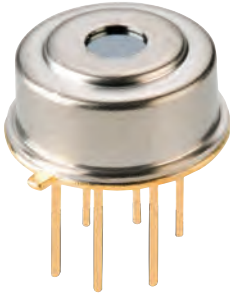

CaliPile Sensors represent the latest innovation in IR sensing from Excelitas. The only one of its kind, the CaliPile is a multifunction, thermal infrared sensor. In addition to traditional non-contact temperature measurement capabilities, the CaliPile offers motion detection and presence monitoring across short to medium ranges.

The TPiS 1T 1084 sensor represents the TO-39 housing version of the CaliPile IR Sensor Series with small optical window also serving as aperture. The sensor is available as calibrated for temperature ranges of 40- 200°C with +/- 3°C for temperature measurement applications working up to 300°C maximum range. Users may reference the maximum temperature setting as trigger level since the interrupt function will alert users when the level is exceeded.

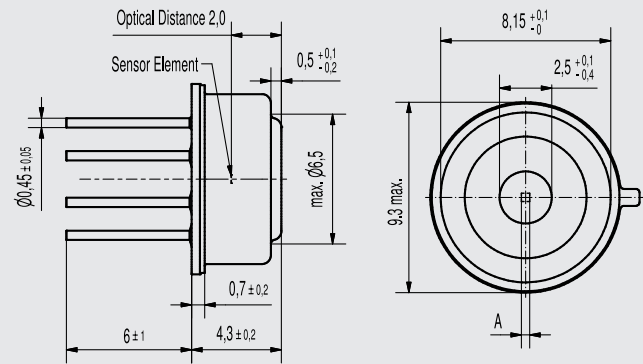
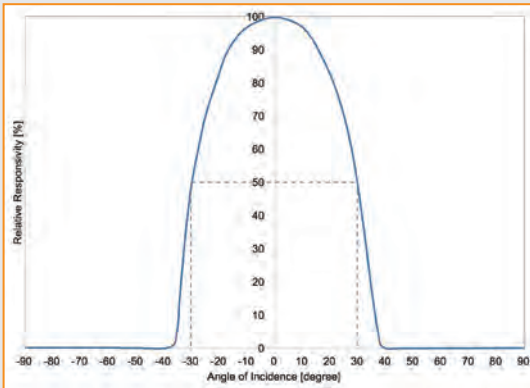

TPiS 1T 1084

Parameter	Symbol	TPiS 1T 1084	Unit	Remarks
Operating Conditions				
Operating Voltage	V _{DD}	2,6...3,6	V	
Supply Current	I _{DD}	15 max.	µA	V _{DD} = 3.3 V
Operating Temperature	T _o	-20...85	°C	Parameters may vary from specified values with temperature dependence.
Storage Temperature	T _s	-40...100	°C	
Thermopile Characteristics				
Sensitive Area	A	0,41 x 0,41	mm ²	Absorber area
Sensitivity (T _{det} 25 °C / T _{obj} 40 °C)	S ₄₀	80	counts/K	
Noise of TP		8	counts	T _{obj} = 40°C, T _{amb} = 25°C
Time Constant	t	15	ms	
Ambient Temperature Sensor Characteristics				
Sensitivity of T _{amb}		170	counts/K	Linear for T _{amb} from 0°C to 85°C
Count @ T _{amb} = 25°C		11000...17000	counts	Range
Optical Characteristics				
Field of View	FoV	60	Degree	At 50% intensity points
Electrical Characteristics				
ADC Resolution T _{obj}		17	Bits	Max Count = 2 ¹⁷
ADC Resolution T _{amb}		15	Bits	Max Count = 2 ¹⁵
ADC Sensitivity of T _{obj}		0,7...0,9	µV/count	
ADC Offset T _{obj}		64000...65000	counts	Range

TPiS 1T 1252B • TPiS 1T 1254 • TPiS 1T 1256 L5.5

DigiPile® – ISOthermal Thermopile Sensors

As continuation of Excelitas' focus on innovation and digitization the DigiPile is a Thermopile with digital 17-bit output. The complete range of detectors is offered with our patented ISOthermal performance. Within the bit stream the thermopile signal is followed by another signal given by an internal temperature reference diode. With the digital output, low interference of electric disturbance is achieved. These features enable optimum designs for ear and forehead thermometry.



TPiS 1T 1252B, TPiS 1T 1254, TPiS 1T 1256 L5.5						
Parameter	Symbol	TPiS 1T 1252B	TPiS 1T 1254	TPiS 1T 1256 L5.5	Unit	Remarks
Operating Conditions						
Operating Voltage	V _{DD}	2,4...3,6	2,4...3,6	2,4...3,6	V	
Supply Current	I _{DD}	15 max.	15 max.	15 max.	µA	V _{DD} = 3.3 V
Operating Temperature	T _O	-20...70	-20...70	-20...70	°C	Parameters may vary from specified values with temperature dependence.
Storage Temperature	T _S	-40...100	-40...100	-40...100	°C	
Thermopile Characteristics						
Sensitive Area	A	0,51 x 0,51	0,51 x 0,51	0,51 x 0,51	mm ²	Absorber area
Sensitivity (T _{det} 25 °C / T _{obj} 40 °C)	S ₄₀	290	150	67	counts/K	
Sensitivity (T _{det} 25 °C / T _{obj} 100 °C)	S ₁₀₀	370	200	85	counts/K	
Noise of TP		8	8	8	counts	T _{obj} = 40°C, T _{amb} = 25°C
Time Constant	t	45	45	45	ms	
Ambient Temperature Sensor Characteristics						
Sensitivity of T _{amb}		90	90	90	counts/K	Linear for T _{amb} from 0°C to 90°C
Count @ T _{amb} = 25°C		7000...9400	7000...9400	7000...9400	counts	Range
Optical Characteristics						
Field of View	FoV	84	56	5	Degree	At 50% intensity points
Electrical Characteristics						
ADC Resolution T _{obj}		17	17	17	Bits	Max Count = 2 ¹⁷
ADC Resolution T _{amb}		14	14	14	Bits	Max Count = 2 ¹⁴
ADC Sensitivity of T _{obj}		0,7...0,9	0,7...0,9	0,7...0,9	µV/count	
ADC Offset T _{obj}		64000...65000	64000...65000	64000...65000	counts	Range

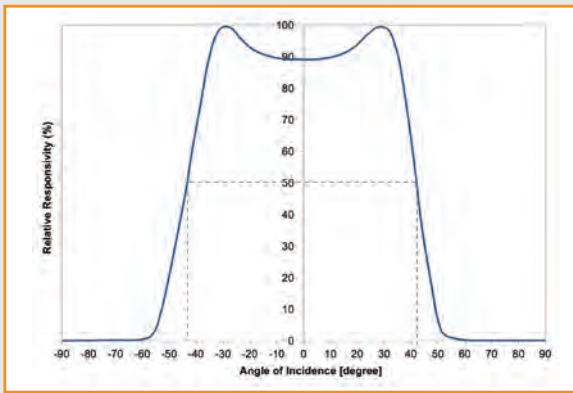

FoV TPIS 1T 1252B

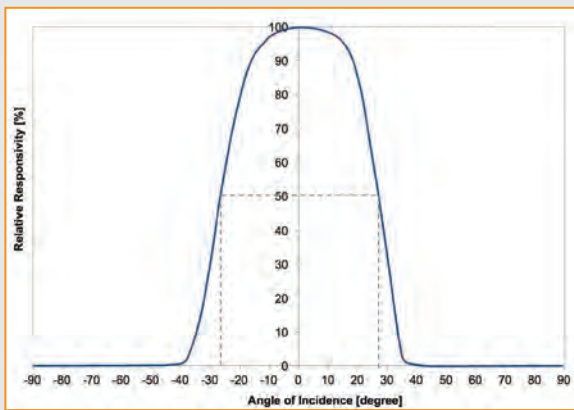
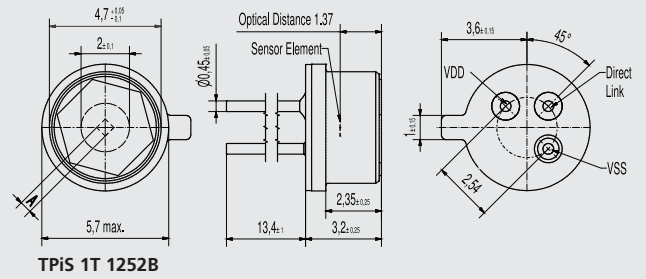

FoV TPIS 1T 1254

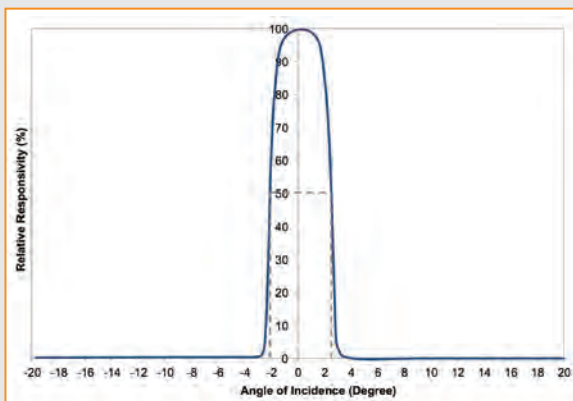
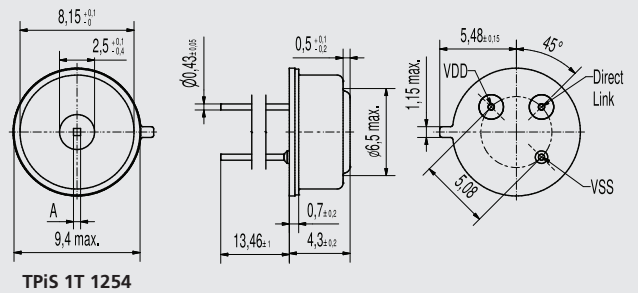

FoV TPIS 1T 1256 L5.5

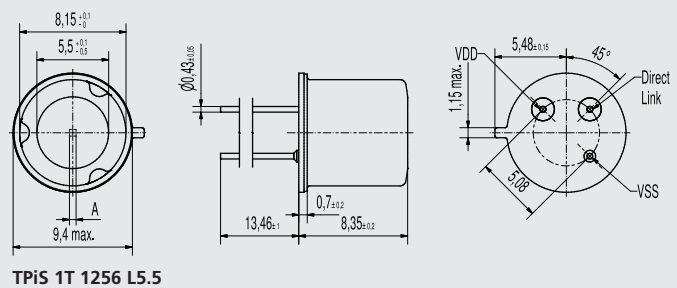

TPiM 1T 0136 L5.5

Thermopile Sensor Module with lens



The Module includes the proven concept of TPMI® in TO-5 housing with integral lens sensor on a PCB with connector for easy plug and play. It senses the thermal radiation emitted by objects and converts this to an analog voltage. The product is fully factory-calibrated for an accurate signal output over a specified temperature range and includes optional temperature compensation. The internal signal processing with 8-bit resolution of the control registers and the EEPROM technology allow for calibration as per customer requirements. The Module includes PCB with connector.

As standard two calibration ranges are provided:

- TPiM 1T 0136 L5.5 OAA250 P7 for up to 250°C
- TPiM 1T 0136 L5.5 OAA060 P7 for up to 60°C

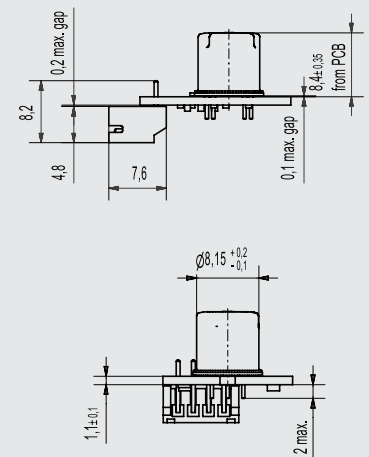
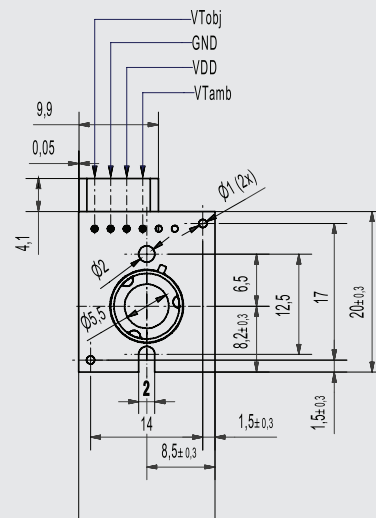
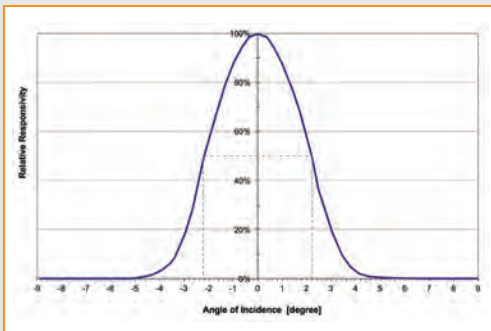

TPiM 1T 0136 L5.5

Parameter	Symbol	TPiM 1T 0136 L5.5	Unit	Remarks
Output Voltage Swing	V _O	0.25...(V _{DD} - 0.25)	V	
Resistive Output Load	R _L	50	kΩ	min.
Object Temp Accuracy		1.5	K	+ / -
Response Time	t _{resp}	100	ms	typ.
Supply Voltage	V _{DD}	4.5...5.5	V	
Supply Current	I _{DD}	1.5	mA	typ. ; R _L > 1MΩ
Operating Temp range	T _O	-25...+100	°C	
Storage Temp range	T _S	-40...+100	°C	
ESD tolerance		2.5	kV	Human body model
Field of View, typ.	FoV	4.5	°	at 50% intensity points
Distance to Spot size ratio	D:S	11:1	Degrees	at 50% intensity points

TPM 1T 0134 M

Thermopile Sensor Module

The Module includes the proven concept of TPMI® in TO-5 housing serving as aperture on a PCB with connector for easy plug and play. The product is fully factory-calibrated for an accurate signal output over a specified temperature range and includes optional temperature compensation. The Module includes PCB with connector and is available with reflector allowing narrow field of view, either to right, left or front side.

As standard calibration we provide:

- TPM 1T 0134 OAA140 P6 M for up to 140°C

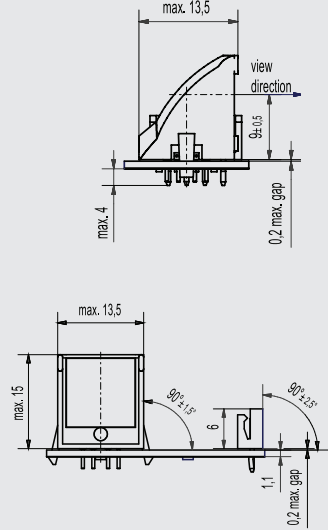
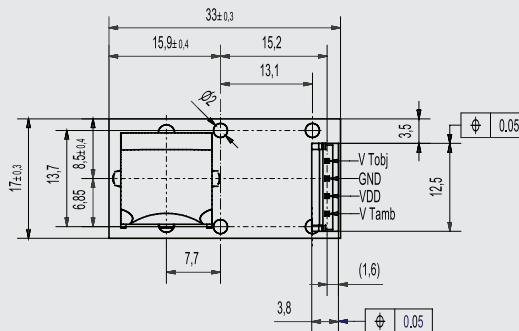
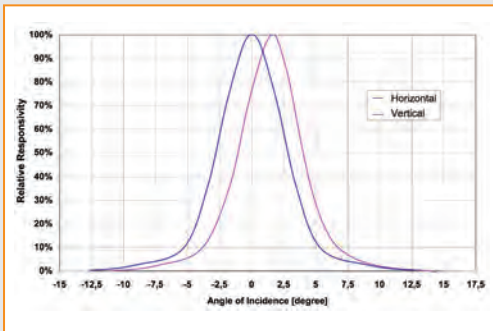
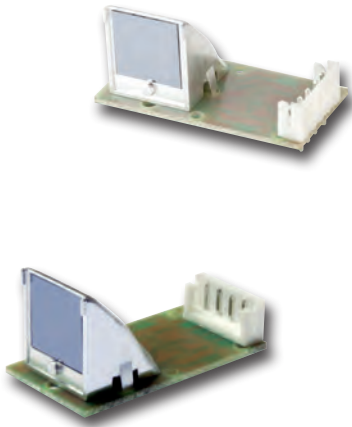

TPM 1T 0134 M				
Parameter	Symbol	TPM 1T 0134 M	Unit	Remarks
Output Voltage Swing	V_o	0.25...(VDD - 0.25)	V	
Resistive Output Load	R_L	50	kΩ	min.
Object Temp Accuracy		1.5	K	+ / -
Response Time	t_{resp}	100	ms	typ.
Supply Voltage	V_{DD}	4.5...5.5	V	
Supply Current	I_{DD}	1.5	mA	typ. ; $R_L > 1M\Omega$
Operating Temp range	T_o	-25...+100	°C	
Storage Temp range	T_s	-40...+100	°C	
ESD tolerance		2.5	kV	Human body model
Field of View, typ.	FoV	5.5	°	at 50% intensity points
Distance to Spot size ratio	D:S	-	Degrees	

Generally Applied IR Windows

Material used for filters and windows must be transparent in the wavelength of interest. Glass for example is generally not suited to sense the temperature of human skin since it absorbs wavelengths above 4µm. Common materials with a broad transmission range are Germanium and Silicon for the filter windows of IR Sensors. For outside protection only few materials are suitable. Among many plastics, only PP or HD-PE can be used as protection or as fresnel structured optics for presence and motion detection.

Detecting Gases

In the early days of the mining industry, the common method for gas detection was to take a bird in a cage along.

Canary birds were well known as an early warning system for toxic gases. If the bird went unconscious, it was high time to get out. Today electronic sensors have replaced the ancient system.



The now applied NDIR principle requires a combination of Thermal Radiation Source and Infrared Sensor. The selection of source strongly depends on spectral range. For range below 5µm popular incandescent miniature lamps can be applied, for long-range thermal sources are required.

When designing NDIR-based gas sensors the selection of available Detectors is split between Pyrodetectors and Thermopile Sensors. Since NDIR usually applies modulated sources to prevent overheating, the engineer has the choice of preference. Both sensor principles can be called equally suitable when fit with the narrow band window necessary for the specific gas absorption.

Special Application Detectors for Gas Sensing

Environmental protection is one of our most serious concerns. Features and instrumentation are required to measure and monitor all kinds of gas in

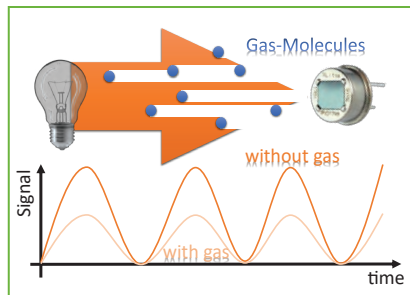

our environment. One of the methods applied is the NDIR technique, a principle of measuring gas concentration by its absorption properties in the infrared range.

Filters for Gas Sensors

The spectral sensitive range of the detectors is defined by a filter window. Common applications in infrared reference wavelengths from 2 to 20 µm. Long-range pyrometers apply a sharp cut-on/cut-off window of 9-14µm (G9) .

Excelitas offers single-channel detectors with such windows as well as Dual-Channel Detectors. When choosing Dual-Channel, typically one channel works as reference fit with a window that will have

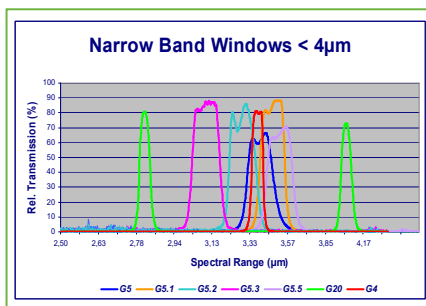

no gas absorption band (G20). For sensing one specific gas by infrared absorption we offer narrow-band filters to detect specific gas absorption lines. The appropriate narrow band optical filters enable detection of Carbon Monoxide,

Carbon Dioxide, Natural Gas and other environmental gases, as well as some technical gases. Please see the range of available filters and specifications.

Fire Detection

Since the exhaust of fire is mainly a hot emission of CO and CO₂, the infrared sensor may also be used for fire detection when fit with a suitable filter.

Our Detectors are applied in single- or dual-channel configurations. With the suited specific narrow-band spectral window our detectors and sensors are a vital part of making our environment more safe, secure and healthy.

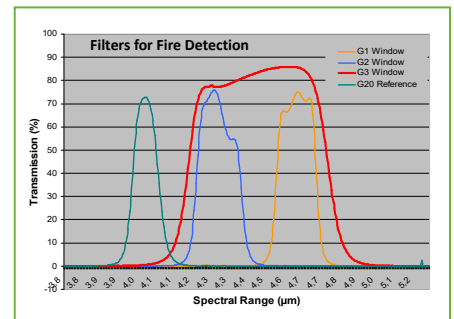

Narrow Bands Filter Table

Filter type	Application	CWL	HPB
G1	CO	4.64µm	180nm
G2	CO ₂	4.26µm	180nm
G2.2	CO ₂	4.43µm	60nm
G2.5	CO ₂	4.33µm	160 nm
G2.6	N ₂ O	4.53µm	85nm
G3	CO+CO ₂	4.48µm	620nm
G4	NO	5.3µm	180nm
G5	HC	3.35µm-3,4µm	190nm
G5.1	HC	3.46µm	163nm
G5.2	HC	3,28-3,31µm	160nm
G5.3	HC	3.09µm	160nm
G5.5	HC	3,32-3,34µm	160nm
G5.6	HC	3.42µm-3,451µm	160nm
G5.7	HC	3,30-3,32µm	160nm
G5.9	HC	3.375µm-3,4µm	190nm
G7.1	R12	11.3µm	200nm
G7.2	R134a	10.27µm	210nm
G7.3		12.4µm	180nm
G20	Reference	3,95µm	90nm



PYS 3198TC

Single-Element Pyrodetector

As Single-Element types we reference designs which combine one sensing element with a suited optical window. This makes single-Element types suitable for measurement applications.

One sensing element is placed in the center of the detector. For thermal compensation an additional element which is blinded from radiation is connected in parallel. The TO-5 Metal Housing is equipped with an optical filter window. For gas measuring applications the spectral range is narrowed to match the gas absorption in IR range. As such the detector window suits as spectral narrow band filter. Various configurations are available for detection of more common gasses.

Features and Benefits

- TO-5 metal housing
- Different spectral filters available
- Suited for gas monitoring

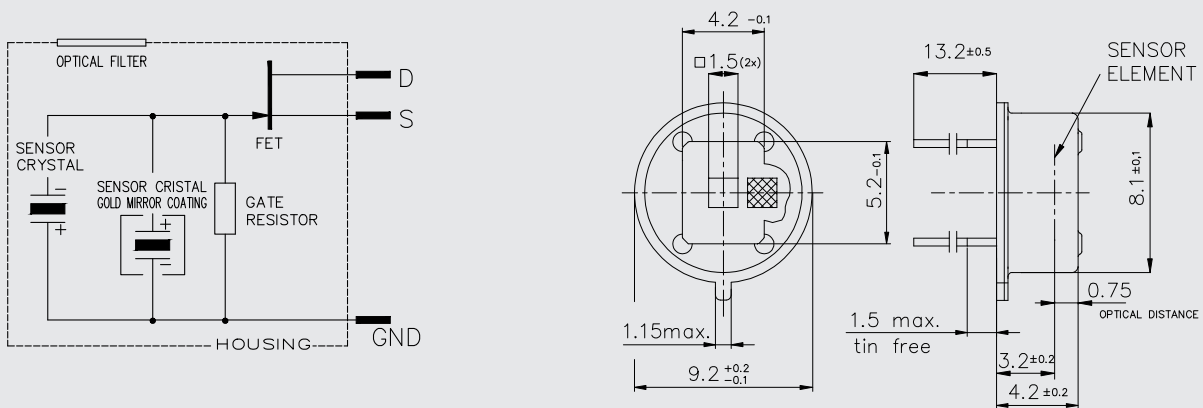

PSY 3198TC

Parameter	Symbol	PYS 3198TC	Unit	Remarks
Responsivity, min.	R_{min}	2.2	kV/W	f = 1 Hz
Responsivity, typ.	R	3.5	kV/W	f = 1 Hz
Noise, max.	N_{max}	50	μV_{pp}	0,4...10Hz/20°C
Noise, typ.	N	15	μV_{pp}	0,4...10Hz/20°C
spec. Detectivity	D^*	17	$10^7 cm^* \sqrt{Hz/W}$	1Hz/ 1Hz BW
Field of View, horizontal	FoV	135	°	unobstructed
Field of View, vertical		122	°	unobstructed
Source Voltage		0,2...1,5	V	47 kΩ, 20°C
Operation Voltage	V_{DD}	2-10	V	unobstructed



PYS 3398TC

Single-Element Pyrodetector

This Single-Element Pyrodetector combines one sensing element with a suited optical window. This makes single-element types suitable for measurement applications. This version of Single-Element Detector is especially resistant to EMI by means of drain resistor and source capacitor.

One sensing element is placed in the center of the detector. For thermal compensation an additional element which is blinded from radiation is connected in parallel. The TO-5 metal housing is equipped with an optical filter window. For gas measuring applications the spectral range is narrowed to match the gas absorption in IR range. As such the detector window suits as spectral narrow-band filter. Various configurations are available for detection of more common gasses.

Features and Benefits

- TO-5 metal housing
- Different spectral filters available
- EMI protection
- Suited for gas monitoring

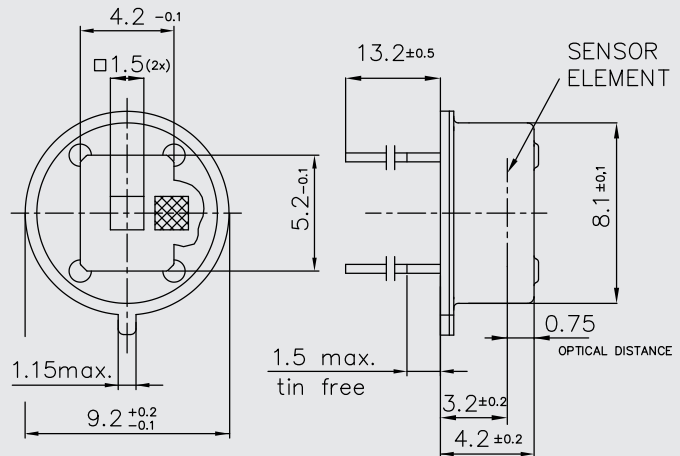
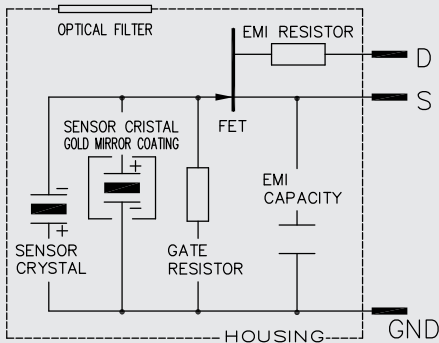

PSY 3398TC

Parameter	Symbol	PYS 3398TC	Unit	Remarks
Responsivity, min.	R_{min}	2.2	kV/W	f = 1 Hz
Responsivity, typ.	R	3.5	kV/W	f = 1 Hz
Noise, max.	N_{max}	50	μV_{pp}	0,4...10Hz/20°C
Noise, typ.	N	15	μV_{pp}	0,4...10Hz/20°C
spec. Detectivity	D^*	17	$10^7 cm^* \sqrt{Hz/W}$	1Hz/ 1Hz BW
Field of View, horizontal	FoV	135	°	unobstructed
Field of View, vertical		122	°	unobstructed
Source Voltage		0,2...1,5	V	47 kΩ, 20°C
Operation Voltage	V_{DD}	2-10	V	unobstructed



PYS 3428TC

Dual-Channel Pyrodetector

This Single-Element, Dual-Channel Pyrodetector includes two single elements thermally compensated. Each output is optically associated with its own optical window within the TO-5 metal housing. They form individual output signals, thus the name "Dual-Channel".

For gas measuring applications the spectral range is narrowed to match the gas absorption in IR range. Usually one channel is used as reference channel suited with a bandwidth which shows no gas absorption. The second channel serves as the gas sensing output. Various filter selections are available to detect the most prominent gasses.

Features and Benefits

- TO-5 metal housing
- Different spectral filters available
- EMI protection
- Suited for gas monitoring

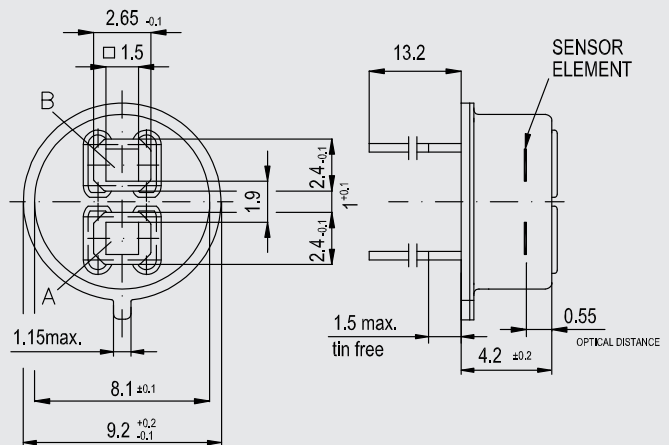
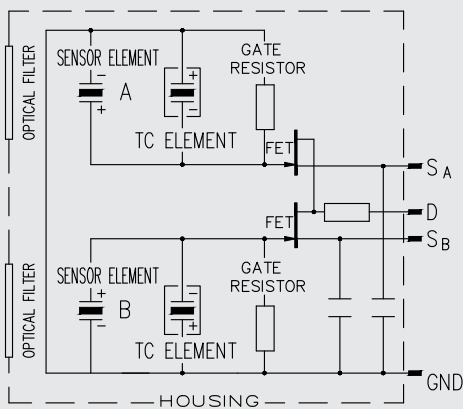

PYS 3428TC

Parameter	Symbol	PYS 3428TC	Unit	Remarks
Responsivity, min.	R_{min}	2.2	kV/W	$f = 1 \text{ Hz}$
Responsivity, typ.	R	3.5	kV/W	$f = 1 \text{ Hz}$
Noise, max.	N_{max}	50	μV_{pp}	0,4...10Hz/20°C
Noise, typ.	N	15	μV_{pp}	0,4...10Hz/20°C
spec. Detectivity	D^*	17	$10^7 \text{ cm}^* \sqrt{\text{Hz/W}}$	1Hz/ 1Hz BW
Field of View, horizontal	FoV	77	°	unobstructed
Field of View, vertical		77	°	unobstructed
Source Voltage		0,2...1,5	V	47 kΩ, 20°C
Operation Voltage	V_{DD}	2-10	V	unobstructed

TPD 1T 0623 • TPD 1T 0823

High-Sensitivity Thermopile Detectors

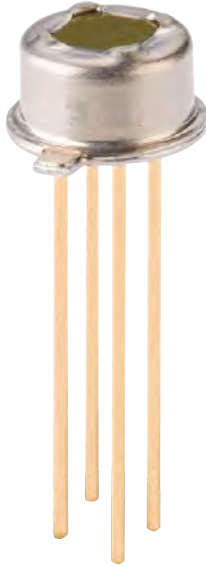

This Thermopile Detector series offered in TO-46 housing with square size window is specially designed for high output signal level. It is equipped with internal Thermistor serving as temperature reference for Thermopile temperature compensation. With the square window size offering wide field of view and the option to select narrow band filters G1...G5 as per page 36 of this brochure it is the best choice for Gas sensing applications.

The TPD1T 0823 is a special version for fast response when needed in gas sensing applications.

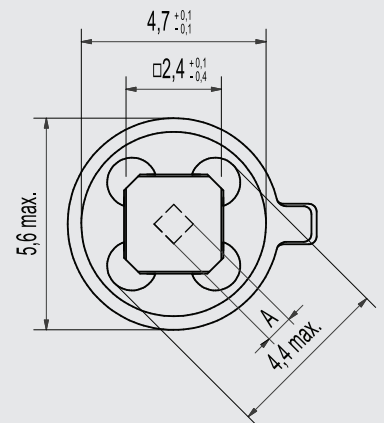
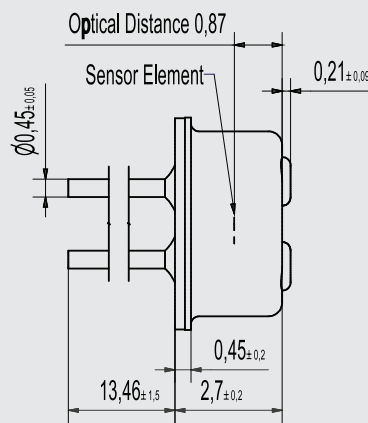
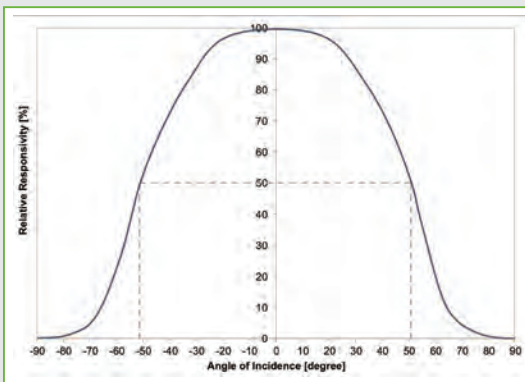

TPD 1T 0623, TPD 1T 0823

Parameter	Symbol	TPD 1T 0623	TPD 1T 0823	Unit	Remarks
Sensitive Area	A	1.2 x 1.2	1.2 x 1.2	mm	Absorber Area
Thermopile Resistance	R _{TP}	50...110	70...120	kΩ	25°C
Responsivity	R	33	32	V/W	500°K / 1Hz / Without IR-filter
Sensitivity (Tdet 25 °C / Tobj 40 °C)	S ₄₀	133	124	μV/K	With standard filter (LWP, cut-on 5.5 μm)
Sensitivity (Tdet 25 °C / Tobj 100 °C)	S ₁₀₀	177	165	μV/K	With standard filter (LWP, cut-on 5.5 μm)
Time Constant	t	27	10	ms	
Noise Voltage	V _n	36	38	nV/√Hz	25°C
Specific Detectivity	D*	1.1	1.1	10 ⁸ cm ² /Hz/W	25°C
Temp. Coefficient of Resistance	TC _{RTP}	0,03	0,03	%/K	
Temp. Coefficient of Responsivity	TC _R	-0,05	-0,05	%/K	
Field of view	FoV	104	104	Degrees	at 50% intensity points
Thermistor resistance (25°C)	R ₂₅	100	100	kΩ	25 °C
Thermistor BETA-value	β	3964	3964	K	defined at 25 °C / 100 °C

TPD 2T 0625 • TPD 2T 0825

High-Sensitivity Thermopile Detectors



This specially designed Detector offers Dual-Channel performance in a TO-39 housing with two individual optical windows. Typically one window is fitted with a reference filter G20, while the other window is fitted with a narrow-band pass filter selected for a specific gas, see page 36 of this brochure for available selection. It also includes the internal Thermistor as temperature reference for Thermopile temperature compensation.

The TPD 2T 0825 is a special version for fast response when needed in critical gas sensing applications.

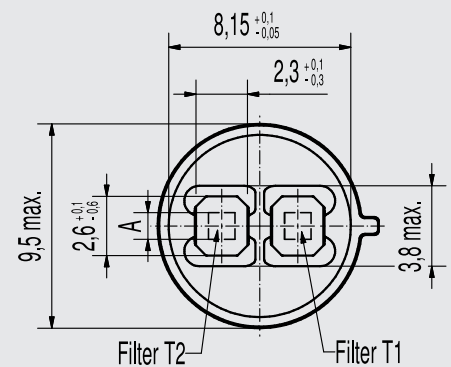
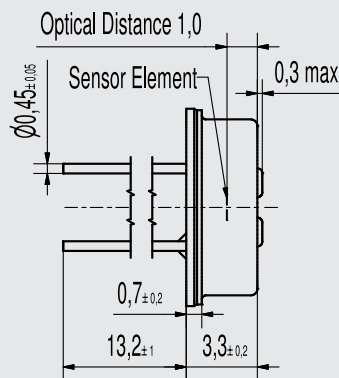
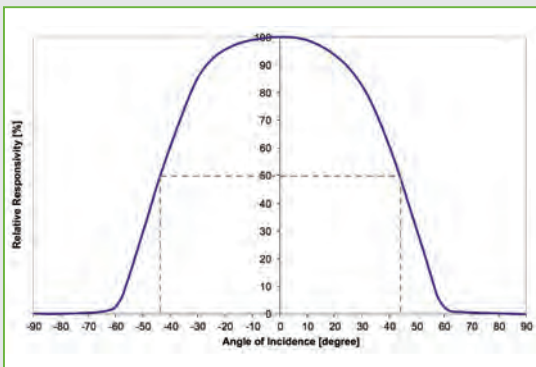

TPD 2T 0625, TPD 2T 0825

Parameter	Symbol	TPD 2T 0625	TPD 2T 0825	Unit	Remarks
Sensitive Area	A	1.2 x 1.2	1.2 x 1.2	mm	Absorber Area
Thermopile Resistance	R _{TP}	50...110	70...120	kΩ	25°C
Responsivity	R	33	32	v/vv	500°K / 1Hz / Without IR-filter
Sensitivity (Tdet 25 °C / Tobj 40 °C)	S ₄₀	115	112	μV/K	With standard filter (LWP, cut-on 5.5 μm)
Sensitivity (Tdet 25 °C / Tobj 100 °C)	S ₁₀₀	155	151	μV/K	With standard filter (LWP, cut-on 5.5 μm)
Time Constant	t	27	10	ms	
Noise Voltage	V _n	36	38	nV/√Hz	25°C
Specific Detectivity	D*	1.1	1.1	10 ⁸ cm√Hz/W	25°C
Temp. Coefficient of Resistance	TC _{RTP}	0,03	0,03	%/K	
Temp. Coefficient of Responsivity	TC _R	-0,05	-0,05	%/K	
Field of view	FoV	87	87	Degrees	at 50% intensity points
Thermistor resistance (25°C)	R ₂₅	100	100	kΩ	25 °C
Thermistor BETA-value	β	3964	3964	K	defined at 25 °C / 100 °C

Handling

Infrared Sensors are Optical devices and require careful handling in production. As to mechanical recommendations:

- Avoid dropping the devices on the production flow.
- Avoid physical force to detector leads, do not bend leads unless necessary.
- Ensure leads are not damaged when manipulating them.

Electrostatic discharges may destroy the detectors. It is recommended to apply the standard precautions for ESD sensitive devices to prevent potential damage.

The detector windows are optical filters with multi-layer coatings.

- Avoid touching the detector window. To clean windows, use only ethyl alcohol with a cotton swab.
- Do not expose Detectors to chemical fluids such as Freon, Trichloroethylene and other aggressive detergents.

Environmental Conditions

With the construction of metal can and spectral window inserted into the can by a special durable epoxy, the detectors are sealed and tested for long-term enclosure. The detector will pass He-leakage test with maximum leakage rate specification of 5×10^{-8} mbar ls-1. Detectors shall not increase noise or change responsivity when exposed to maximum of 95% relative humidity at 30°C.

- Avoid long-term storage at high humidity with high temperatures.

As IR detectors are optical sensors, avoid condensation effects on the detector. Operation below dew points may affect the performance.

Reliability Standards

Excelitas' continuous reliability qualification and monitoring program ensures that all outgoing products meet quality and reliability standards. Tests are performed according to approved semiconductor device standards, such as IEC, MIL, and JEDEC (see table). For detailed information please contact Excelitas.

Quality and Reliability Standards

Excelitas strives to meet applicable quality and reliability standards. We are certified ISO 9001:2015 and operate at established SPC and TQM. We are proud to operate under Environmental Management System according to ISO 14001:2015 and the Occupational Safety and Health Management System according to OHSAS 18001: 2007.

All devices employing PCB assemblies are manufactured according IPC-A-610 class 2 guidelines.

Excelitas Thermal Infrared Sensor product line is certified for ANSI/ESD S.20:2014.

In case of questions please feel free to contact us for the latest update on our current certificates and forms. Our continuous qualification and reliability program ensures that all products meet the specified performance criteria.

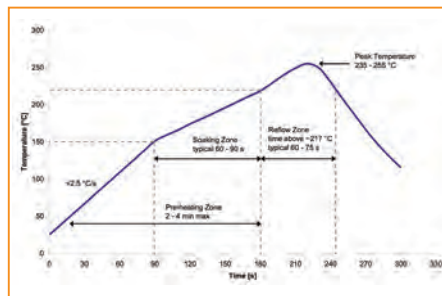

As to outgoing inspection, all devices have to pass 100% testing of major parameters and gross leak in acc. to MIL Std. 883 m 1014C1. Due to high-volume production individual data are not protocolled or stored, statistical data are kept for reference.

Soldering of SMD Devices

The TPiD 1S and TPiS 1S series are lead-free components and fully comply with the RoHS regulations, especially with existing roadmaps of lead-free soldering. Reflow soldering is recommended. A typical lead free reflow profile is shown in figure 4. Specific reflow soldering parameters depend on the solder alloy used.

The device meets MSL1 at 245 °C according to JEDEC standard.

Soldering Conditions

For the soldering of the detectors within PCBs, the typically applied and recommended process is wave soldering. During the automatic wave solder process we strongly advise to restrict preheating to avoid heat exposure through the detector window, if necessary apply a protection cap. When the detector is directly exposed to the radiation of such heaters the detector shall be protected from that heat. Manual soldering is also possible when maintaining similar temperature profiles.

Reflow soldering is not possible for TO housing versions of our detectors. For our range of SMD housing detectors please reference the recommended solder profile.

THERMAL IR SENSORS - SELECTION GUIDE

Pyro Detectors

Pyro Detectors	Analog /Digital	TO5	TO39	SMD	Wall Mount	Ceiling Mount	Gas Monitor	Supply
Dual Element Detectors								
PYD 1398	A1	X			X			2-10V
PYD 1388	A1	X			X			2-10V
PYD 1378	A1	X			X			2-10V
PYD 1798	D1	X			X			3.0V
PYD 1798	D1	X			X			1.8V
PYD 1788	D1	X			X			3.0V
PYD 1598	D1	X			X			1.8V
PYD 1588	D1	X			X			1.8V
PYD 2592	D1			X	X			1.8V
PYD 1794	D1		X		X			3.0V
PYD 2792	D1			X	X			1.8V
Quad Element Detectors								
PYQ 2498	A2	X			X			2-10V
PYQ 1398	A1	X				X		2-10V
PYQ 5448	A2	X				X		2-10V
PYQ 1348	A1	X				X		2-10V
PYQ 1748	D1	X				X		3.0V
PYQ 1548	D1	X				X		1.8V
PYQ 5848	D2	X				X		3.0V
PYQ 2898	D2	X			X			3.0V
Gas Detectors								
PYS 3198	A1						X	2-10V
PYS 3398	A1						X	2-10V
PYS 3428	A2						X	2-10V

Thermopile Detectors

Thermopile Detectors and Sensors	Analog / Digital	TO5	TO39	TO46	SMD	Temp Monitor	Gas Monitor	Presence Detection
TPD 1T 0122 L3.0	A			X		X		
TPD 1T 0122	A			X		X		
TPD 1T 0223	A			X		X		
TPiD 1T 0224	A		X			X		
TPiD 1T 0624	A		X			X		
TPD 1T 0226 IRA	A	X				X		
TPiD 1T 0226 L5.5	A	X				X		
TPiD 1T 0122B	A			X		X		
TPiD 1T 0222B	A			X		X		
TPiD 1T 0622B	A			X		X		
TPiD 1S 0121	A				X	X		
TPiD 1S 0222	A				X	X		
TPiS 1S 1051	D				X	X		
TPiS 1S 1252	D				X	X		
TPiS 1T 1252B	D			X		X		
TPiS 1T 1254	D		X			X		
TPiS 1T 1256 L5.5	D	X				X		
TPiS 1S 1385	D				X			X
TPiS 1S 0185	D				X			X
TPiS 1T 1086 L5.5	D	X				X		
TPiS 1T 0186 L5.5	D	X				X		
TPiS 1T 1084	D		X			X		
TPM 1T 0134 M	A		X			X		
TPiM 1T 0136 L5.5	A	X				X		
TPD 1T 0623	A			X			X	
TPD 1T 0823	A			X			X	

About Excelitas Technologies

Excelitas Technologies® Corp. is a leading industrial technology manufacturer focused on delivering innovative, market-driven photonic solutions to meet the illumination, optical, optronic, sensing, detection and imaging needs of our OEM and end-user customers. Serving a vast array of applications across biomedical, scientific, semiconductor, industrial manufacturing, safety, security, consumer products, defense and aerospace sectors, Excelitas stands committed to enabling our customers' success in their many various end-markets. Our team consists of more than 7,500 professionals working across North America, Europe and Asia, to serve customers worldwide.

www.excelitas.com

Excelitas Technologies

22001 Dumberry Road
Vaudreuil-Dorion, Quebec
Canada J7V 8P7
Telephone: (+1) 450.424.3300
Toll-free: (+1) 800.775.6786
Fax: (+1) 450.424.3345

Excelitas Technologies

GmbH & Co. KG
Wenzel-Jaksch-Str. 31
D-65199 Wiesbaden
Germany
Telephone: (+49) 611 492 430
Fax: (+49) 611 492 165

Excelitas Technologies

8 Tractor Road
Singapore 627969
Telephone: (+65) 6775-2022
Fax: (+65) 6778 1752

For a complete listing of our global offices, visit www.excelitas.com/Locations

Copyright ©2020, Excelitas Technologies Corp. All rights reserved.
DigiPile™ and CoolEye™ are trademarks of Excelitas Technologies Corp.
Excelitas®, CaliPile®, DigiPyro® and TPMI® are registered trademarks of Excelitas Technologies Corp.
All other trademarks are the property of their respective owners.

IR Sensing Catalog 132.55, D-IR_IR Sensing Solutions_2020.01-V4.1_Vers. 2

Stay Connected

