

DESCRIPTION: MALE - SOLDER CUP / MACHINED - PREMIUM

WILL ACCEPT 26-20 AWG WIRE

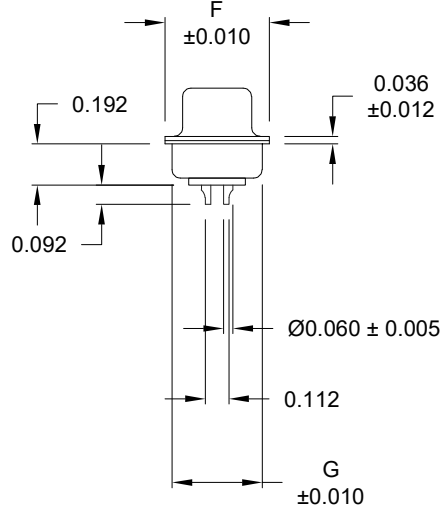
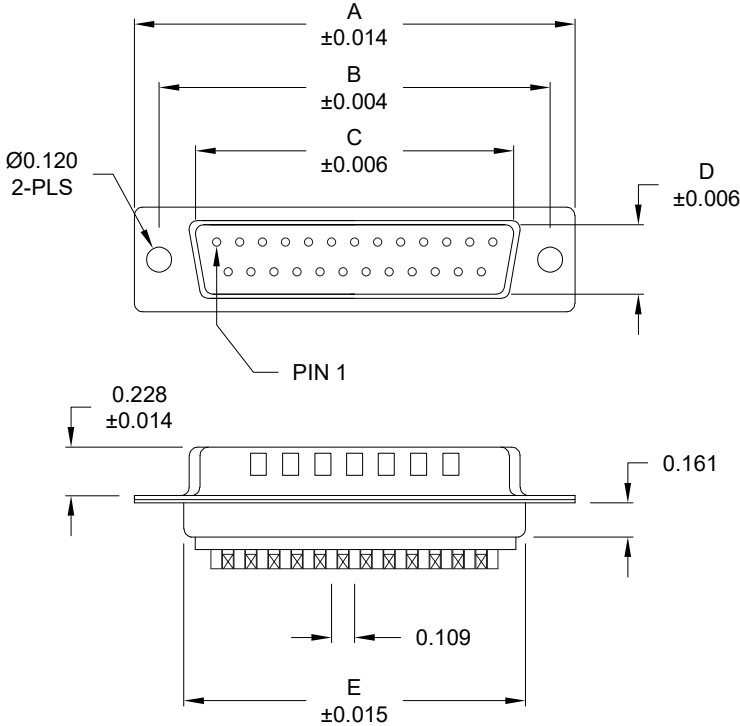

		DIMENSIONS						
No. OF PINS		A	B	C	D	E	F	G
9		1.213	0.984	0.669	0.331	0.760	0.496	0.429
		30.80	24.99	17.00	8.40	19.30	12.60	10.90
15		1.541	1.312	0.996	0.331	1.083	0.496	0.429
		39.15	33.32	25.30	8.40	27.51	12.60	10.90
25		2.088	1.852	1.535	0.331	1.630	0.496	0.429
		53.04	47.04	39.00	8.40	41.40	12.60	10.90
37		2.729	2.500	2.181	0.331	2.276	0.496	0.429
		69.32	63.50	55.40	8.40	57.81	12.60	10.90
50		2.635	2.406	2.079	0.437	2.182	0.598	0.535
		66.93	61.11	52.80	11.10	55.42	15.20	13.60

172-YYY-103RYY1

- SERIES _____
- POSITIONS _____
- 009
- 015
- 025
- 037
- 050
- GENDER _____
- 1 = MALE
- TERMINATION _____
- 0 = SOLDER CUP
- SHELL PLATING _____
- 3 = NICKEL (GROUND INDENTS)
- HARDWARE OPTIONS _____
- 00 = NO HARDWARE
- 01 = .065" CLINCH NUT (SOLDER SIDE)
- 02 = .250" CLINCH NUT (SOLDER SIDE)
- 03 = .250" CLINCH NUT (MATING SIDE)
- 05 = .237" 4-40 BOARD LOCK
- 91 = .237" 4-40 SPACER/ BOARD LOCK
- PLATING OPTIONS _____
- 1 = GOLD FLASH
- 2 = 30MICRO-INCH GOLD

MATERIAL:
 SHELL: STEEL, NICKEL PLATED
 INSULATOR: PA6T, UL94 V-0
 PROCESS TEMP.: 260°C
 CONTACT: BRASS

ELECTRICAL:
 CURRENT RATING: 5 AMPS
 CONTACT RESISTANCE: 15 mOhms Max.
 INSULATION RESISTANCE: 1,000 MOhms Min.
 VOLTAGE: 500VAC FOR 1 MINUTE
 TEMPERATURE: -50° C TO 100° C

DO NOT SCALE FROM DRAWING

	THESE DRAWINGS AND SPECIFICATIONS ARE THE PROPERTY OF NorComp AND SHALL NOT BE REPRODUCED, COPIED OR USED AS THE BASIS FOR THE MANUFACTURE OF SALE OF APPARATUS WITHOUT WRITTEN PERMISSION.		DRAWN: PAM JENKINS	DATE: 08-24-98
	<h1>NorComp</h1>		SCALE: NTS	SHEET OF 1 2
DWG NO. 172-YYY-103RYY1				

RoHS COMPLIANT

ALL CLINCH-NUTS ARE 4-40 INTERNAL THREADS

01X 0.065" (SOLDER SIDE)

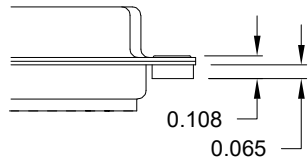

02X 0.250" (SOLDER SIDE)

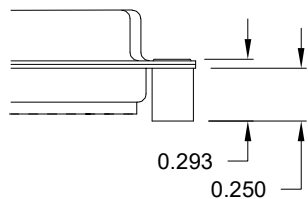

03X..... 0.250" (MATING SIDE)

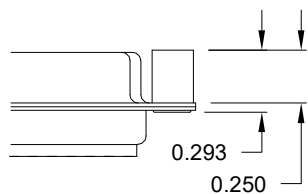

05X 0.237" (SOLDER SIDE)

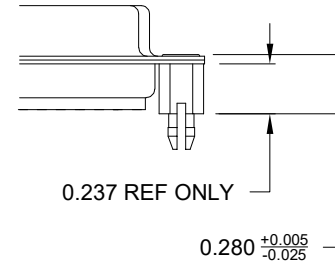

91X 0.237" (SOLDER SIDE)

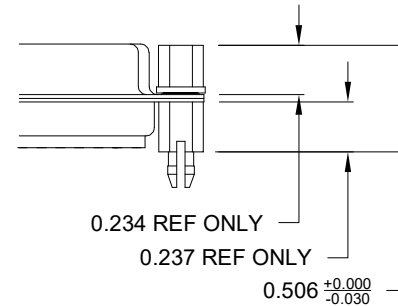

TOLERANCE:
ALL DIMENSIONS ARE ± 0.010
UNLESS OTHERWISE
SPECIFIED

NOTE: 4-40 FEMALE SCREW LOCK IS REMOVABLE

DO NOT SCALE FROM DRAWING

RoHS COMPLIANT

	THESE DRAWINGS AND SPECIFICATIONS ARE THE PROPERTY OF NorComp AND SHALL NOT BE REPRODUCED, COPIED OR USED AS THE BASIS FOR THE MANUFACTURE OF SALE OF APPARATUS WITHOUT WRITTEN PERMISSION.		DRAWN: PAM JENKINS	DATE: 08-24-98
	NorComp		SCALE: NTS	SHEET OF 2 2
DWG NO. 172-YYY-103RYY1				