

DD52R-E | Electronic position indicators

direct drive, 6-digit display, technopolymer



METRIC

- 1
- 2
- 3
- 4
- 5
- 6
- 7
- 8
- 9
- 10
- 11
- 12
- 13
- 14
- 15
- 16
- 17
- 18
- RH

BASE AND CASE

High-resistance polyamide based (PA) technopolymer. Black base.

Case in the following colours:

- C2: RAL 2004 orange, glossy finish.
- C3: RAL 7035 grey, glossy finish.

Available on request in RAL 7021 grey-black colour (C1).

Cover with perfectly sealed gasket and AISI 304 stainless steel UNI 6955 type self-tapping screws with six-lobe socket TORX®T06 (registered trademark by TEXTRON INC.).

The ultrasonic welding between the base and the case prevents separation and avoids dust and liquid penetration.

BOSS

AISI 304 stainless steel with $\varnothing 20$ mm H7 reamed hole, fitting to shaft by means of AISI 304 stainless steel grub screw, hexagon socket and cup end UNI 5929-85, included in the supply.

WINDOW

Transparent polyamide based (PA-T) technopolymer, moulded over the case and with a perfect seal. Resistant to solvents, oils, greases and other chemical agents (avoid contact with alcohol during cleaning operations).

DISPLAY

- 6-digit LCD of 12,0 mm height and special characters.

The visualization parameters can be set and modified by the operator by means of appropriate keys:

- values displayed in mm, inches or degrees
- display of mode for use (absolute or incremental mode)
- reading orientation (right or reverse).

KEYBOARD

Polyester membrane. Resistant to solvents, alcohol, acids, alkalis.

INTERNAL GASKET

O-ring front sealing in NBR synthetic rubber, between the case and the boss.

Brass bushing with double O-ring sealing in NBR synthetic rubber inside the rear cavity of the base (DD52R-E-SST-IP67).

REAR GASKET

Foam polyethylene, supplied.

STANDARD EXECUTIONS

- **DD52R-E-SST-IP65**: completely sealed indicator with IP 65 protection class, see EN 60529 table (on page A-19).

- **DD52R-E-SST-IP67**: completely sealed indicator with IP 67 protection class, see EN 60529 table (on page A-19) obtained by means of a brass bushing with double seal ring inside the rear cavity of the base.

ASSEMBLY INSTRUCTIONS

1. Drill a $\varnothing 6$ mm by 10 mm hole in the body of the machine with a 30 mm centre distance from the spindle to fit the rear referring pin.
2. Fit the indicator onto the spindle and make sure that the referring pin fit the hole.
3. Clamp the boss to the spindle by tightening the grub screw with hexagon socket and cup end, according to UNI 5929-85.

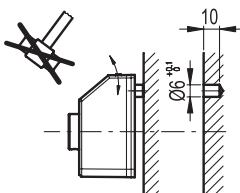

ELESA Original design

ACCESSORIES ON REQUEST (TO BE ORDERED SEPARATELY)

- **MDX-52**: polyamide based (PA) technopolymer knob.
- **RB52-SST**: AISI 304 stainless steel reduction sleeves.

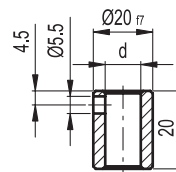

RB52-SST



Code	Description	dH7	Δ
CE.97941	RB52-12-SST-304	12	32
CE.97951	RB52-14-SST-304	14	26
CE.97956	RB52-15-SST-304	15	22
CE.97961	RB52-16-SST-304	16	18

- **BSA52-E**: die-cast zinc alloy bases for spindle locking, epoxy resin coating, black colour, matte finish. GN 302 adjustable handle with die-cast zinc alloy lever body and AISI 304 stainless steel clamping element. A $\varnothing 6.1$ mm hole to fit the referring pin of the indicator. Handle positioned either on the right or on the left. Fitting to the machine by means of two M4 cylindrical-head screws (not included in the supply).

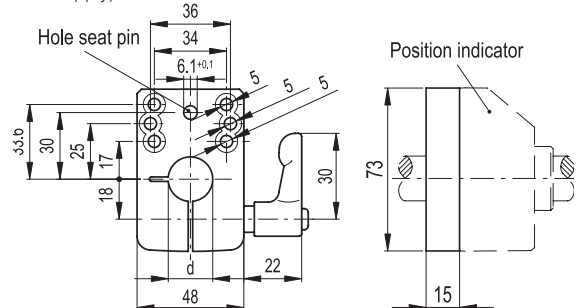

METRIC

Code	Description	dH7	Δ
CE.99091	BSA52-E-12	12	249
CE.99093	BSA52-E-14	14	245
CE.99094	BSA52-E-15	15	243
CE.99095	BSA52-E-16	16	242
CE.99099	BSA52-E-20	20	230

FEATURES AND APPLICATIONS

DD52R-E position indicators, with battery power supply, can be used on passing through shafts in any position to provide the reading of the absolute or incremental positioning of a machine component.

The 6-digit display of 12,0 mm height ensures excellent readability even from a distance and from different viewing angles.

The window in transparent technopolymer protects the LCD display against accidental shocks.

The high protection degree, IP 65 or IP67, makes the indicator suitable for applications that require frequent washing, even with intense water jets.

In the operating mode, by using the 4 function keys, it is possible to select the incremental or the absolute mode, the unit of measure (mm, inches or degrees), reset the absolute counter or load a preset source value and the preset offset value.

In the programming mode, through the 4 function keys, it is possible to program the reading after one revolution of the shaft, the direction of rotation, the display orientation, the resolution (number of decimal digits displayed), the source value and the offset value, the max. speed of rotation and set the functions of the keys for the different options available.

The internal battery has a battery life up to 5 years. A specific symbol appears on the display when the battery needs replacing. It is easy to replace the battery by removing the front cover (Fig. 1) without having to remove the indicator from the drive shaft and without losing the configuration parameters.

Further technical information available in "Operating instructions".

Mechanical and electrical characteristics	
Power supply	Lithium battery CR2477 3.0 V
Battery life	up to 5 years
Display	6-digit LCD of 12 mm height and special characters
Reading scale	-199999; 999999
Number of decimal digits	programmable ⁽¹⁾
Unit of measure	mm, inches, degrees programmable ⁽¹⁾
Rotation max. speed	300/600/1000 r.p.m ⁽²⁾ programmable ⁽¹⁾
Resolution	10.000 impulses / revolution
Protection class	IP65 or IP67
Working temperature	0 + 50 °C
Storing temperature	-20 + +60 °C
Relative humidity	Max. 95% at 25°C without condensation
Interference protection	Complies with Directive 2014/30/EU (EMC)

(1) See the operating instructions.

(2) Default: 600 r.p.m.

Higher rotation speed to 600 r.p.m. can be maintained for short periods of time.

The value of the max. speed affects the battery life.

Battery life depends on the conditions of use (setup, temperature, ...). The indicated value is an estimate made in temperature conditions > 20 °C & < 30 °C, and default setup. Furthermore, this value refers to the condition of the device when it leaves the Elessa factory. Long storage times must always be considered for the estimation of the battery life when the device becomes operational.

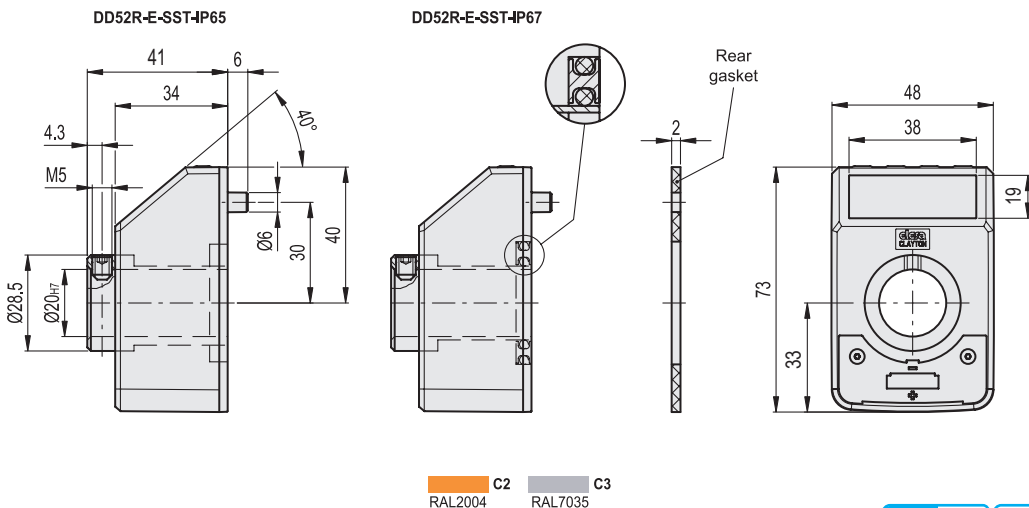
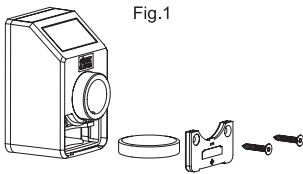

INOX STAINLESS STEEL METRIC

Code	Description	⚖
CE.99052	DD52R-E-SST-IP65-C2	129
CE.99051	DD52R-E-SST-IP65-C3	129
CE.99062	DD52R-E-SST-IP67-C2	141
CE.99061	DD52R-E-SST-IP67-C3	141

