

High-Efficiency 2 MHz Synchronous Buck Converter

Feature

- Input Voltage range: 2.3V to 5.5V
- Output Down to 1V/ 600 mA
- 2 MHz PWM Operation
- Ultra-Fast Transient Response (Typical 200 kHz GBW)
- Internal Compensation
- All Ceramic Capacitors
- >95% Efficiency
- Fully Integrated MOSFET Switches
- Easily Synchronized to External Clock
- SYNCLOCK Feature to Daisy Chain Multiple 2204
- <340 μ A Quiescent Current
- Logic Controlled Micropower Shutdown
- Thermal Shutdown and Current Limit Protection
- 10-pin MSOP and 3 mm x 3 mm VDFN-10L
- -40°C to $+125^{\circ}\text{C}$ Junction Temperature Range

Applications

- High-Efficiency Portable Power
- Cellular Phones/PDAs
- 802.11 WLAN Power Supplies
- RF Power Supplies
- Li-Ion Battery Powered Applications

General Description

The MIC2204 is a high-efficiency, 2 MHz PWM synchronous buck switching regulator. Power conversion efficiency of above 95% is easily obtainable over a wide range of applications. A proprietary internal compensation technique ensures stability with the smallest possible inductor and ceramic output capacitor.

The MIC2204 operates from 2.3V to 5.5V input and features internal power MOSFETs that can supply over 600 mA of output current with output voltages down to 1V. The MIC2204 implements a constant 2 MHz pulse width modulation (PWM) control scheme which reduces spurious noise in sensitive RF and communication applications. Additionally, the MIC2204 can be synchronized to an external clock, or multiple MIC2204 can easily be daisy chained with the SYNCLOCK feature.

The MIC2204 has a high bandwidth loop (typ. 200 kHz) which allows ultra-fast transient response times. This is very useful when powering applications that require fast dynamic responses, such as the CPU cores and RF circuitry in high performance cellular phones and PDAs.

The MIC2204 is available in 10-pin MSOP and 3 mm x 3 mm VDFN-10L package options with an operating junction temperature range from -40°C to $+125^{\circ}\text{C}$.

Package Types

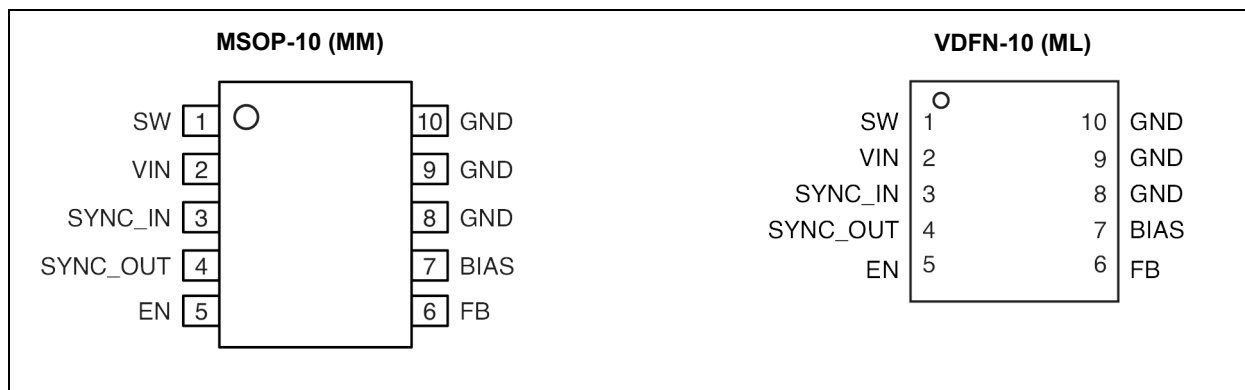

MIC2204

Functional Block Diagram

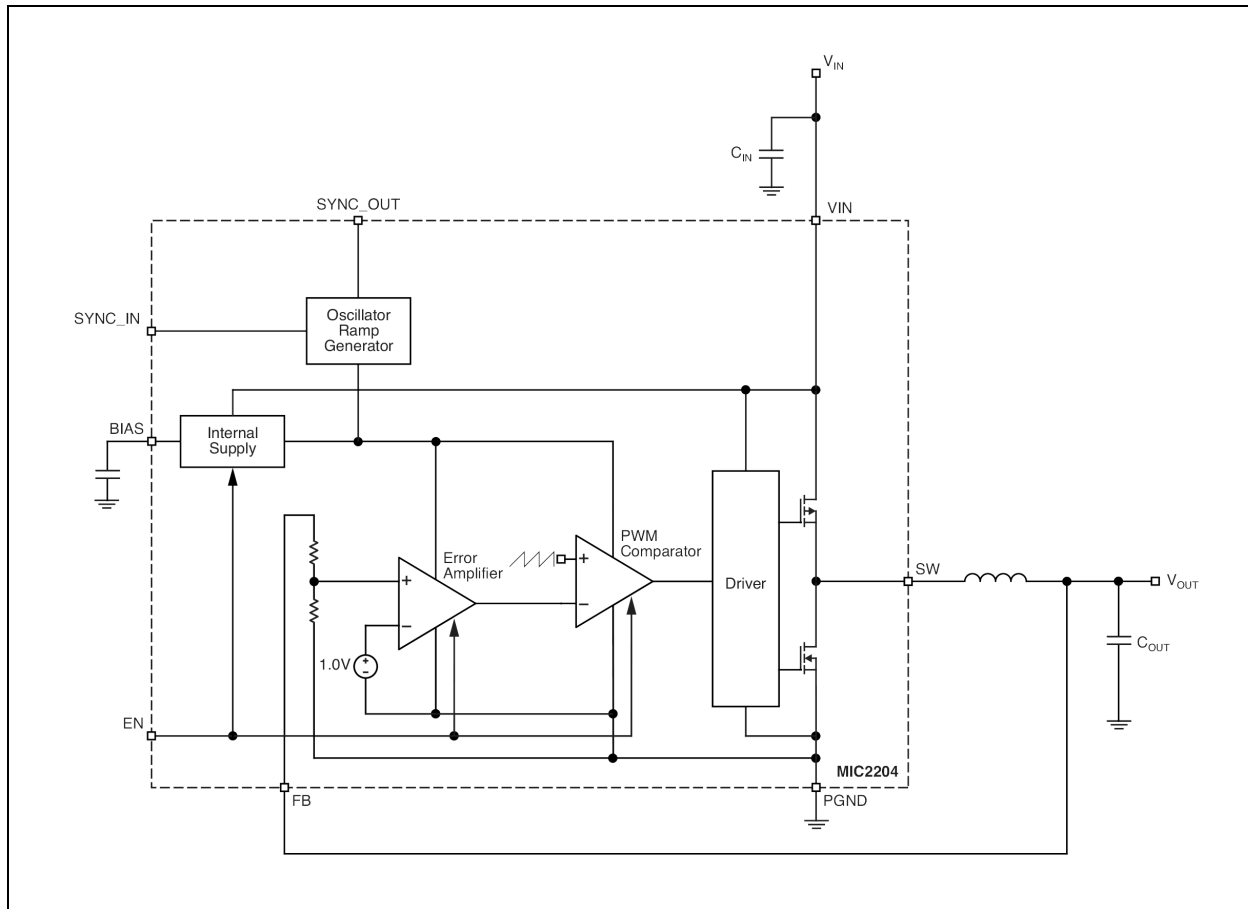

Typical Application Circuit

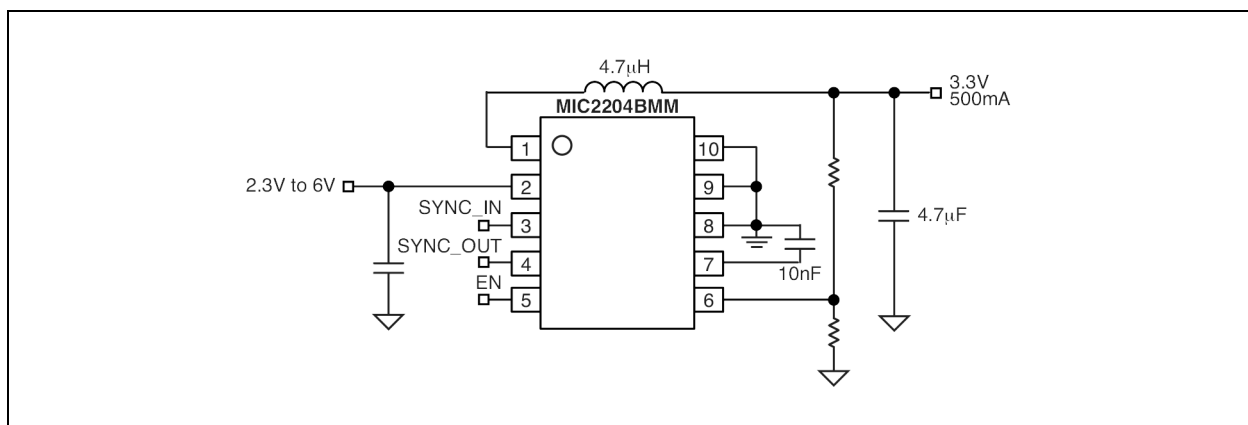

1.0 ELECTRICAL CHARACTERISTICS

Absolute Maximum Ratings †

Supply Voltage (V_{IN})6V
Output Switch Voltage (V_{SW})6V
Logic Input Voltage (V_{EN}, V_{SYNC_IN}) V_{IN} to $-0.3V$
Power Dissipation (Note 1)	
Storage Temperature $-65^{\circ}C$ to $+150^{\circ}C$

Operating Ratings ‡

Supply Voltage (V_{IN}) +2.3V to +5.5V
Junction Temperature (T_J) $-40^{\circ}C$ to $+125^{\circ}C$
Package Thermal Resistance	
MSOP-10 (θ_{JA}) 115°C/W
VDFN-10 (θ_{JA}) 60°C/W

† **Notice:** Stresses above those listed under “Absolute Maximum Ratings” may cause permanent damage to the device. This is a stress rating only and functional operation of the device at those or any other conditions above those indicated in the operational sections of this specification is not intended. Exposure to maximum rating conditions for extended periods may affect device reliability. Specifications are for packaged product only.

‡ **Notice:** The device is not guaranteed to function outside its operating ratings.

ELECTRICAL CHARACTERISTICS (Note 2)

Electrical Characteristics: $V_{IN} = V_{EN} = 3.5V$, $T_A = 25^{\circ}C$, **Bold** values indicate $-40^{\circ}C \leq T_A \leq +125^{\circ}C$; unless otherwise noted.

Parameter	Symbol	Min.	Typ.	Max.	Units	Conditions
Supply Voltage Range	—	2.3	—	5.5	V	—
Current Limit	—	0.6	1.2	2	A	$V_{FB} = 0.7V$
Quiescent Current	—	—	320	450	μA	$V_{FB} = 1.1V$
	—	—	6.0	15	μA	$EN = 0V$
Feedback Voltage	—	0.98	1.0	1.02	V	—
Output Voltage Line Regulation	—	—	0.2	—	%	$V_{OUT} = 1V$, $V_{IN} = 2.3V$ to $5.5V$, $I_{LOAD} = 100 mA$
Output Voltage Load Regulation	—	—	0.2	—	%	$0 mA < I_{LOAD} < 500 mA$
Maximum Duty Cycle	—	100	—	—	%	$V_{FB} = 0.7V$
Switch On-Resistance	—	—	0.72	—	Ω	$I_{SW} = 300 mA$, $V_{FB} = 0.7V$
	—	—	0.55	—	Ω	$I_{SW} = -300 mA$, $V_{FB} = 1.1V$
Oscillator Frequency	—	1.8	2	2.2	MHz	—
SYNC Frequency Range	—	1.8	—	2.5	MHz	—
SYNC_IN Threshold	—	—	1.2	—	V	—
SYNC Minimum Pulse Width	—	—	10	—	ns	—
SYNC_IN Input Current	—	—	1	2	μA	—

MIC2204

ELECTRICAL CHARACTERISTICS (Note 2)

Electrical Characteristics: $V_{IN} = V_{EN} = 3.5V$, $T_A = 25^\circ C$, **Bold** values indicate $-40^\circ C \leq T_A \leq +125^\circ C$; unless otherwise noted.

Parameter	Symbol	Min.	Typ.	Max.	Units	Conditions
Enable Threshold	—	0.52	0.72	0.96	V	—
Enable Hysteresis	—	—	20	—	mV	—
Enable Input Current	—	—	1	2	μA	—
Overtemperature Shutdown	—	—	160	—	$^\circ C$	—
Overtemperature Shutdown Hysteresis	—	—	20	—	$^\circ C$	—

- Note 1:** Absolute maximum power dissipation is limited by maximum junction temperature where $P_{D(MAX)} = (T_{J(MAX)} - T_A) \div \theta_{JA}$.
- 2:** Specification for packaged product only.

TEMPERATURE SPECIFICATIONS (Note 1)

Parameters	Symbol	Min.	Typ.	Max.	Units	Conditions
Temperature Ranges						
Storage Temperature	T_S	-65	—	+150	$^\circ C$	—
Junction Temperature Range	T_J	-40	—	+125	$^\circ C$	—
Package Thermal Resistances						
Thermal Resistance 10-Lead MSOP	θ_{JA}	—	115	—	$^\circ C/W$	—
Thermal Resistance 10-Lead VDFN	θ_{JA}	—	60	—	$^\circ C/W$	—

- Note 1:** The maximum allowable power dissipation is a function of ambient temperature, the maximum allowable junction temperature and the thermal resistance from junction to air (i.e., T_A , T_J , θ_{JA}). Exceeding the maximum allowable power dissipation will cause the device operating junction temperature to exceed the maximum $+125^\circ C$ rating. Sustained junction temperatures above $+125^\circ C$ can impact the device reliability.

2.0 TYPICAL PERFORMANCE CURVES

Note: The graphs and tables provided following this note are a statistical summary based on a limited number of samples and are provided for informational purposes only. The performance characteristics listed herein are not tested or guaranteed. In some graphs or tables, the data presented may be outside the specified operating range (e.g., outside specified power supply range) and therefore outside the warranted range.

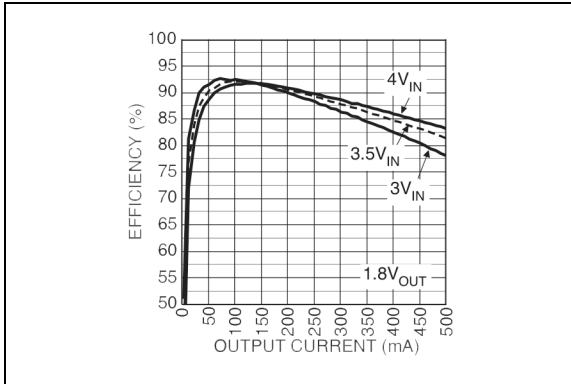

FIGURE 2-1: Efficiency vs. Output Current.

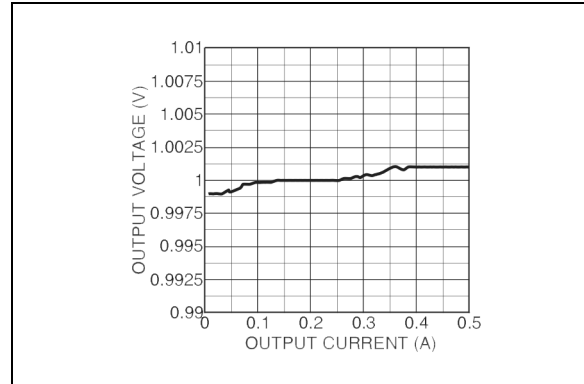

FIGURE 2-4: Output Voltage vs. Output Current.

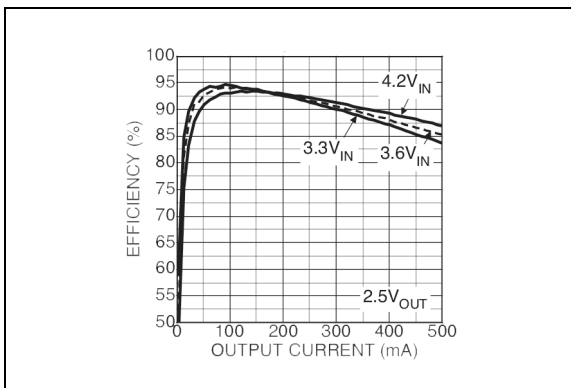

FIGURE 2-2: Efficiency vs. Output Current.

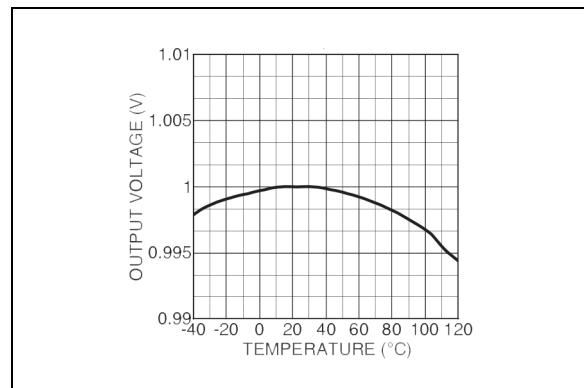

FIGURE 2-5: Output Voltage vs. Temperature.

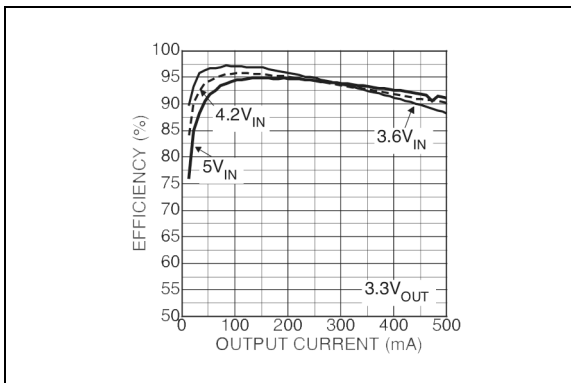

FIGURE 2-3: Efficiency vs. Output Current.

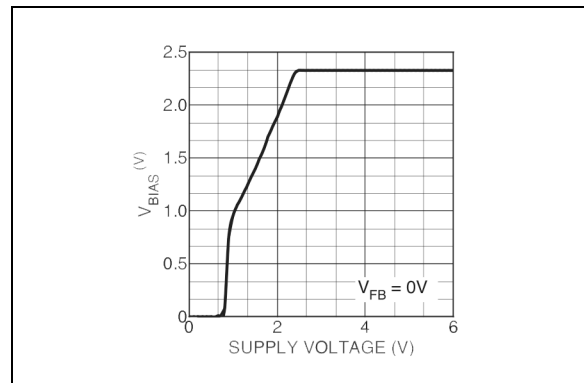

FIGURE 2-6: V_{BIAS} vs. Supply Voltage.

MIC2204

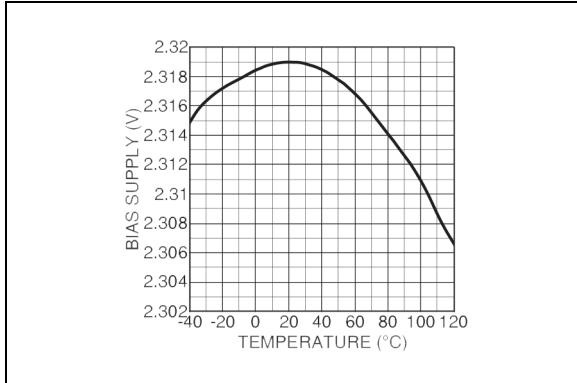

FIGURE 2-7: *BIAS Supply vs. Temperature.*

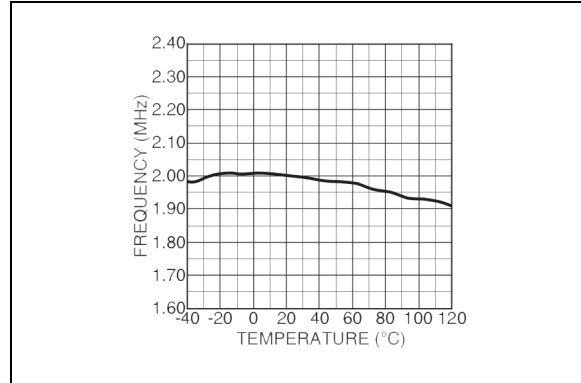

FIGURE 2-10: *Frequency vs. Temperature.*

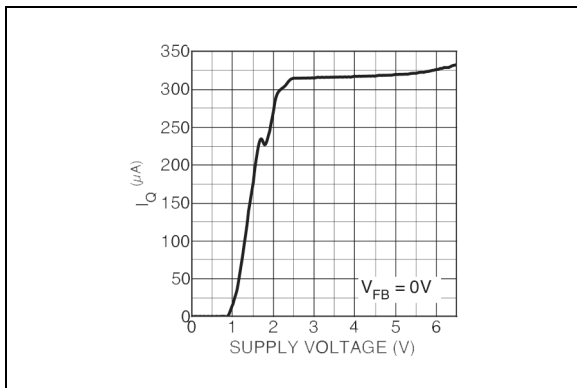

FIGURE 2-8: *Quiescent Current vs. Supply Voltage.*

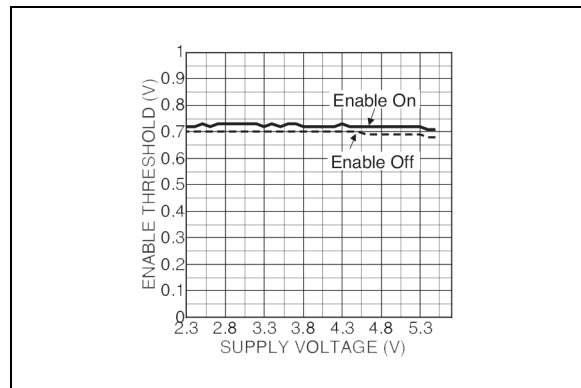

FIGURE 2-11: *Enable Threshold vs. Supply Voltage.*

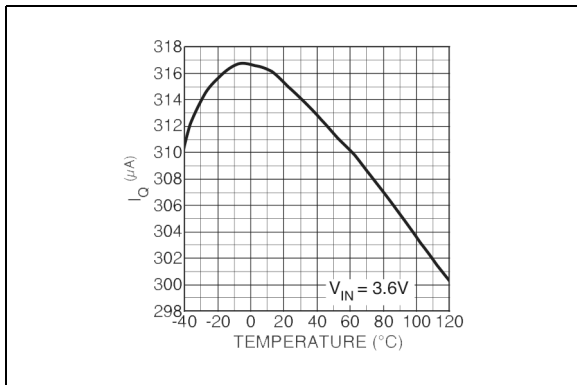

FIGURE 2-9: *Quiescent Current vs. Temperature.*

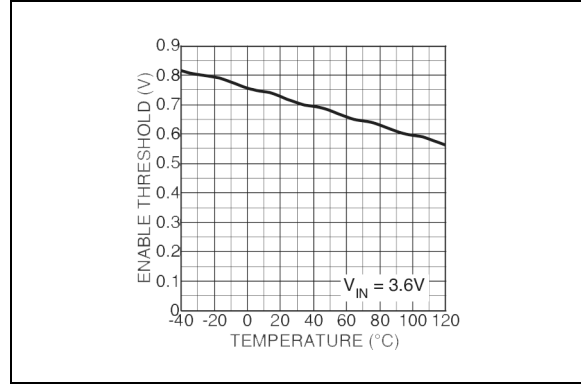

FIGURE 2-12: *Enable Threshold vs. Temperature.*

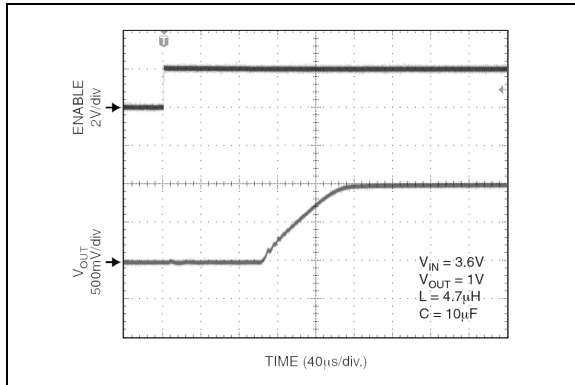

FIGURE 2-13: Startup from Enable.

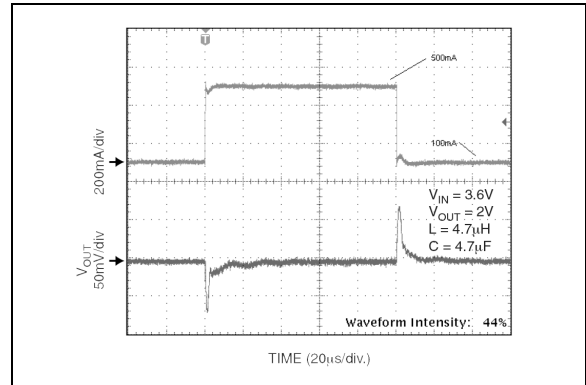

FIGURE 2-16: Load Transient Response.

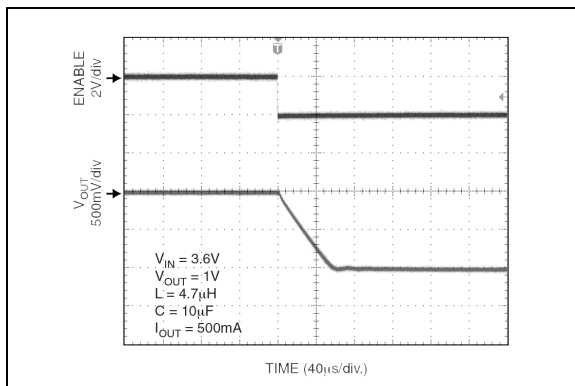

FIGURE 2-14: Shutdown from Enable.

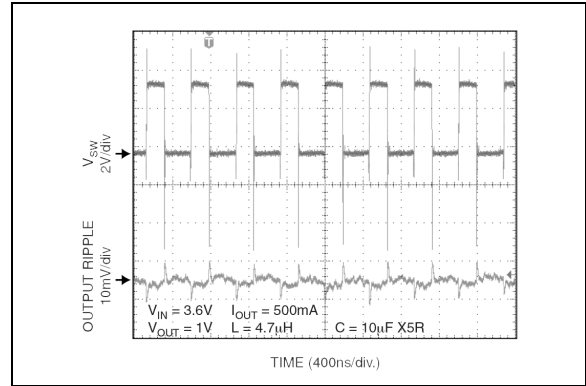

FIGURE 2-17: Switch Waveform Output Ripple.

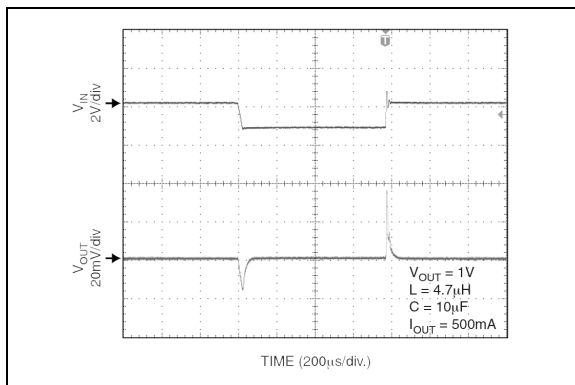

FIGURE 2-15: Line Transient Response.

MIC2204

3.0 PIN DESCRIPTIONS

The descriptions of the pins are listed in [Table 3-1](#).

TABLE 3-1: PIN FUNCTION TABLE

Pin Number	Pin Name	Description
1	SW	Switch (Output): Internal power MOSFET output switches.
2	VIN	Supply Voltage (Input): Requires bypass capacitor to GND.
3	SYNC_IN	SYNC_IN for the MIC2204: Sync the main switching frequency to an external clock. Tie pin to ground if not using this function. Tying SYNC_IN high reduces the switching frequency to 1.6 MHz (See Section 5.0, Applications Information).
4	SYNC_OUT	SYNC_OUT an open collector output to feed into SYNC_IN. Float or ground the SYNC_OUT pin if not using sync out function.
5	EN	A low level EN will power down the device, reducing the quiescent current to under 15 μ A (typ. 6.5 μ A).
6	FB	Input to the error amplifier, connect to the external resistor divider network to set the output voltage.
7	BIAS	Internal circuit bias supply, nominally 2.3V. Must be de-coupled to signal ground with a 0.01 μ F capacitor.
8, 9, 10	GND	Ground.

4.0 FUNCTIONAL DESCRIPTION

4.1 VIN

VIN provides power to the output and to the internal bias supply. The supply voltage range is from 2.3V to 5.5V. A minimum 1 μ F ceramic is recommended for bypassing the input supply.

4.2 Enable

The enable pin provides a logic level control of the output. In the off state, supply current of the device is greatly reduced (typically 6.5 μ A). Also, in the off state, the output drive is placed in a tri-stated condition, where both the high-side P-Channel MOSFET and the low-side N-Channel are in an off or non conducting state. Do not drive the enable pin above the supply voltage.

4.3 SYNC_IN

SYNC_IN enables the ability to change the fundamental switching frequency. The SYNC_IN frequency has a minimum frequency of 1.8 MHz and a maximum sync frequency of 2.5 MHz.

Careful attention should be paid to not driving the SYNC_IN pin greater than the supply voltage. While this will not damage the device, it will cause improper operation.

4.4 SYNC_OUT

Since SYNC_OUT is an open collector output that provides a signal equal to the internal oscillator frequency, multiple MIC2204 to be connected together in a master slave configuration for frequency matching of the converters. A typical 10 k Ω is recommended for a pull-up resistor.

4.5 BIAS

The bias supply is an internal 2.3V linear regulator that supplies the internal biasing voltage to the MIC2204. A 10 nF ceramic capacitor is required on this pin for bypassing. Do not use the BIAS pin as a supply. The BIAS pin was designed to supply internal power and not external circuitry.

4.6 Feedback

The feedback pin provides the control path to control the output. A resistor divider connecting the feedback to the output is used to adjust the desired output voltage. Refer to the material in [Section 5.0, Applications Information](#) for more details.

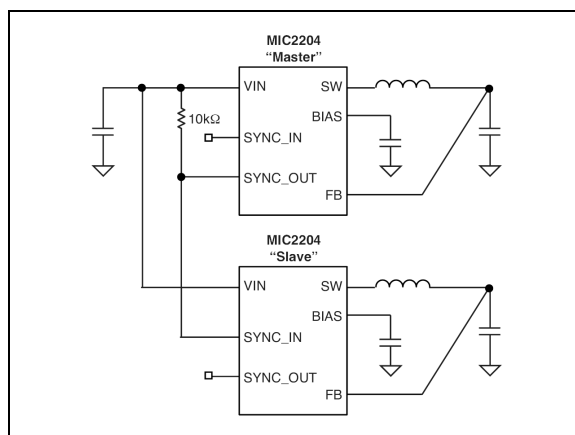

FIGURE 4-1: SYNC_OUT.

MIC2204

5.0 APPLICATIONS INFORMATION

5.1 Input Capacitor

A minimum 1 μF ceramic is recommended on the V_{IN} pin for bypassing. X5R or X7R dielectrics are recommended for the input capacitor. Y5V dielectrics are not recommended: they lose most of their capacitance over temperature and also become resistive at high frequencies. This reduces their ability to filter out high frequency noise.

5.2 Output Capacitor

The MIC2204 was designed specifically for the use of a 4.7 μF ceramic output capacitor. The output capacitor requires either an X7R or X5R dielectric. Y5V and Z5U dielectric capacitors, aside from the undesirable effect of their wide variation in capacitance over temperature, become resistive at high frequencies. Using Y5V or Z5U capacitors will cause instability in the MIC2204. For output voltages less than 1.6V, a 10 μF capacitor may be required for stability. See [Section 5.6, Compensation](#) for more detail.

Total output capacitance should not exceed 15 μF . Large values of capacitance can cause current limit to engage during start-up. If larger than 15 μF is required, a feed-forward capacitor from the output to the feedback node should be used to slow the start-up time.

5.3 Inductor Selection

Inductor selection will be determined by the following (not necessarily in the order of importance):

- Inductance
- Rated current value
- Size requirements
- DC resistance (DCR)

The MIC2204 is designed for use with a 4.7 μH inductor.

Maximum current ratings of the inductor are generally given in two methods: permissible DC current and saturation current. Permissible DC current can be rated either for a 40°C temperature rise or a 10% loss in inductance. Ensure the inductor selected can handle the maximum operating current.

When saturation current is specified, make sure that there is enough margin that the peak current will not saturate the inductor.

The size requirements refer to the area and height requirements that are necessary to fit a particular design. Please refer to the inductor dimensions on their data sheet.

DC resistance is also important. While DCR is inversely proportional to size, DCR can represent a significant efficiency loss. Refer to [Section 5.5, Efficiency Considerations](#) below for a more detailed description.

[Table 5-2](#) shows a list of recommended 4.7 μH inductors by manufacturer, part number and key specifications.

TABLE 5-1: COMPONENT SELECTION

Manufacturer	Part Number	H (mm)	W (mm)	L (mm)	DCR (m Ω)
Sumida	CDRH3D18NP-4R7NC	2	3.8	3.8	86
Murata	LQH43PH4R7M26L	2.8	3.2	4.5	74
Murata	LQH32PN4R7NNCL	2.2	2.5	3.2	155
Coilcraft	XGL3520-472ME	2	3.2	3.5	63
Low Profile					
TDK	SPM5010T-4R7M-LR	1	1	4	215
Sumida	0410CDMC-CDS-4R7MC	1	4.2	4.4	211

5.4 Bias Capacitor

A small 10 nF ceramic capacitor is required to bypass the BIAS pin. The use of low ESR ceramics provides improved filtering for the bias supply.

5.5 Efficiency Considerations

Efficiency is defined as the amount of useful output power, divided by the amount of power consumed.

EQUATION 5-1:

$$Efficiency = \left(\frac{V_{OUT} \times I_{OUT}}{V_{IN} \times I_{IN}} \right) \times 100$$

Maintaining high efficiency serves two purposes. It reduces power dissipation in the power supply, reducing the need for heat sinks and thermal design considerations and it reduces consumption of current for battery powered applications. Reduced current draw from a battery increases the devices operating time, critical in handheld devices.

There are two loss terms in switching converters: DC losses and switching losses. DC losses are simply the power dissipation of I^2R . For example, power is dissipated in the high-side switch during the on cycle, where power loss is equal to the high-side MOSFET $R_{\text{DS(ON)}}$ multiplied by the switch current². During the off cycle, the low-side N-Channel MOSFET conducts, also dissipating power. Device operating current also

reduces efficiency. The product of the quiescent (operating) current and the supply voltage is another DC loss. The current required to drive the gates on and off at a constant 2 MHz frequency and the switching transitions make up the switching losses.

Figure 5-1 shows an efficiency curve. On the non shaded portion, from 0 to 200 mA, efficiency losses are dominated by quiescent current losses, gate drive and transition losses. In this case, lower supply voltages yield greater efficiency in that they require less current to drive the MOSFETs and have reduced input power consumption.

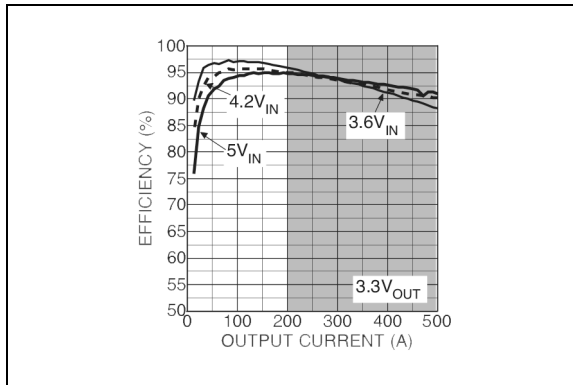

FIGURE 5-1: Efficiency vs. Output Current.

On the shaded region, 200 mA to 500 mA, efficiency loss is dominated by MOSFET $R_{DS(ON)}$ and inductor losses. Higher input supply voltages will increase the gate-to-source threshold on the internal MOSFETs, reducing the internal $R_{DS(ON)}$. This improves efficiency by reducing DC losses in the device. All but the inductor losses are inherent to the device, making inductor selection even more critical in efficiency calculations. As the inductors are reduced in size, the DC resistance (DCR) can become quite significant. The DCR losses can be calculated as follows:

EQUATION 5-2:

$$L_{PD} = I_{OUT}^2 \times DCR$$

From that, the loss in efficiency due to inductor resistance can be calculated as follows:

EQUATION 5-3:

$$EfficiencyLoss = \left[1 \pm \left(\frac{V_{OUT} \times I_{OUT}}{V_{OUT} \times I_{OUT} + L_{PD}} \right) \right] \times 100$$

Efficiency loss due to DCR is minimal at light loads and gains significance as the load is increased. Inductor selection becomes a trade-off between efficiency and size in this case.

5.6 Compensation

The MIC2204 is an internally compensated, voltage mode buck regulator. Voltage mode is achieved by creating an internal 2 MHz ramp signal and using the output of the error amplifier to pulse-width modulate the switch node, maintaining output voltage regulation. With a typical gain bandwidth of 200 kHz, the MIC2204 is capable of extremely fast transient responses.

The MIC2204 is designed to be stable with a 4.7 μ H inductor and a 4.7 μ F ceramic (X5R) output capacitor for output voltages greater than 1.6V. For output voltages less than 1.6V, a 10 μ F capacitor is required. Also, when a feed forward capacitor is used, the gain bandwidth is increased to unity gain. This will also require increasing the output capacitor to 10 μ F.

5.7 Feedback

The MIC2204 provides a feedback pin to adjust the output voltage to the desired level. This pin connects internally to an error amplifier. The error amplifier then compares the voltage at the feedback to the internal 1V reference voltage and adjusts the output voltage to maintain regulation. To calculate the resistor divider network for the desired output is as follows:

EQUATION 5-4:

$$R2 = \frac{R1}{\left(\frac{V_{OUT} \pm 1}{V_{REF}} \right)}$$

Where:
 $V_{REF} = 1.0V$
 $V_{OUT} = \text{Desired Output Voltage}$

A 10 k Ω or lower resistor value from the output to the feedback is recommended. Larger resistor values require an additional capacitor (feed-forward) from the output to the feedback. The large high-side resistor value and the parasitic capacitance on the feedback pin (~10 pF) can cause an additional pole in the loop. The additional pole can create a phase loss at high-frequency. This phase loss degrades transient response by reducing phase margin. Adding feed-forward capacitance negates the parasitic capacitive effects of the feedback pin.

A minimum 1000 pF capacitor is recommended for feed-forward capacitance.

Also, large feedback resistor values increase the impedance, making the feedback node more susceptible to noise pick up. A feed-forward capacitor would also reduce noise pick up by providing a low impedance path to the output.

When using a feed-forward capacitor, the gain bandwidth of the device reaches unity gain at high-frequency. Therefore, output capacitance will need to be increased to a minimum 10 μ F. For more information on output capacitor selection for stability, see [Section 5.6, Compensation](#).

5.8 PWM Operation

The MIC2204 is a pulse-width modulation (PWM) controller. By controlling the ratio of on-to-off time, or duty cycle, a regulated DC output voltage is achieved. As load or supply voltage changes, so does the duty cycle to maintain a constant output voltage. In cases where the input supply runs into a dropout condition, the MIC2204 will run at 100% duty cycle.

The MIC2204 provides constant switching at 2 MHz with synchronous internal MOSFETs. The internal MOSFETs include a high-side P-Channel MOSFET from the input supply to the switch pin and an N-Channel MOSFET from the switch pin to ground. Since the low-side N-Channel MOSFET provides the current during the off cycle, a free wheeling Schottky diode from the switch node to ground is not required.

PWM control provides fixed frequency operation. By maintaining a constant switching frequency, predictable fundamental and harmonic frequencies are achieved. Other methods of regulation, such as burst and skip modes, have frequency spectrum that changes with load and can interfere with sensitive communication equipment.

5.9 Synchronization

SYNC_IN allows the user to change the frequency from 2 MHz up to 2.5 MHz or down to 1.8 MHz. This controls the fundamental frequency and all the resultant harmonics. Maintaining a predictable frequency creates the ability to either shift the harmonics away from sensitive carrier and I_F frequency bands, or to accurately filter out specific harmonic frequencies.

Connecting the SYNC_OUT function pin to the SYNC_IN of other MIC2204 will synchronize multiple MIC2204 in a daisy-chain. Synchronizing multiple MIC2204 means that regulators will run at the same fundamental frequency, resulting in matched harmonic frequencies and simplifying design for sensitive communication equipment.

6.0 PACKAGING INFORMATION

6.1 Package Marking Information

10-Lead VDFN*

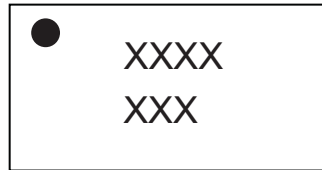

Example

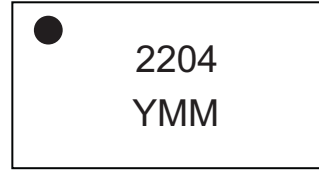

10-Lead MSOP*

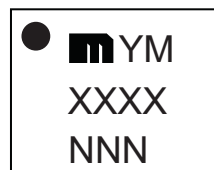

Example

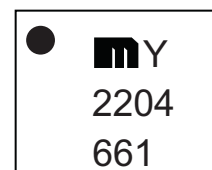

Legend:	XX...X	Product code or customer-specific information
	Y	Year code (last digit of calendar year)
	YY	Year code (last 2 digits of calendar year)
	WW	Week code (week of January 1 is week '01')
	NNN	Alphanumeric traceability code
	(e3)	Pb-free JEDEC® designator for Matte Tin (Sn)
	*	This package is Pb-free. The Pb-free JEDEC designator ((e3)) can be found on the outer packaging for this package.
	•, ▲, ▼	Pin one index is identified by a dot, delta up, or delta down (triangle mark).
Note:	In the event the full Microchip part number cannot be marked on one line, it will be carried over to the next line, thus limiting the number of available characters for customer-specific information. Package may or may not include the corporate logo.	
	Underbar (_) and/or Overbar (¯) symbol may not be to scale.	

MIC2204

10-Lead MSOP (MM) Package Outline and Recommended Land Pattern

TITLE

10 LEAD MSOP PACKAGE OUTLINE & RECOMMENDED LAND PATTERN

DRAWING #	MSOP-10LD-PL-1	UNIT	INCH [MM]
-----------	----------------	------	-----------

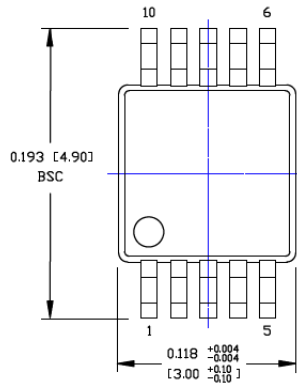

TOP VIEW

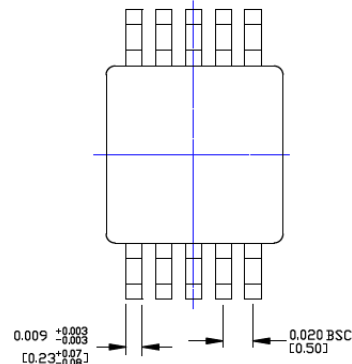

BOTTOM VIEW

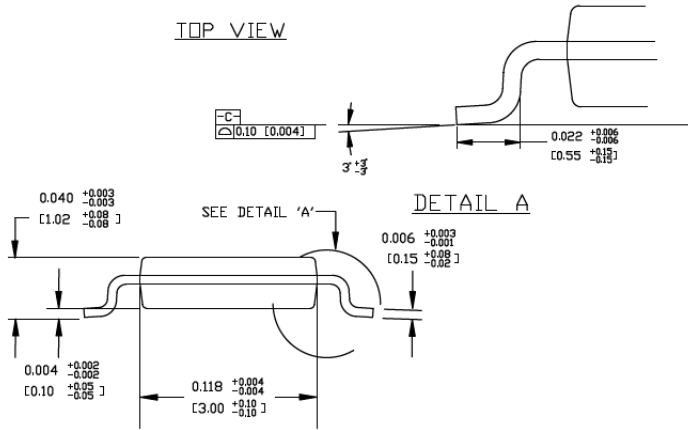

DETAIL A



SIDE VIEW

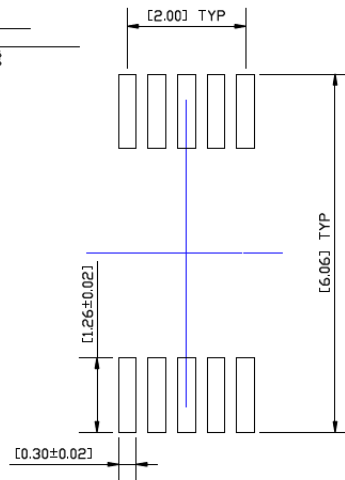

RECOMMENDED LAND PATTERN

NOTES:

1. DIMENSIONS ARE INCHES [MM].
2. CONTROLLING DIMENSION: MM.
3. DIMENSION DOES NOT INCLUDE MOLD FLASH OR PROTRUSIONS, EITHER OF WHICH SHALL NOT EXCEED 0.008 [0.20] PER SIDE.

Note: For the most current package drawings, please see the Microchip Packaging Specification located at <http://www.microchip.com/packaging>.

10-Lead VDFN (ML) Package Outline and Recommended Land Pattern



10-Lead Very Thin Plastic Dual Flat, No Lead Package (9Q) - 3x3 mm Body [VDFN]

Note: For the most current package drawings, please see the Microchip Packaging Specification located at <http://www.microchip.com/packaging>

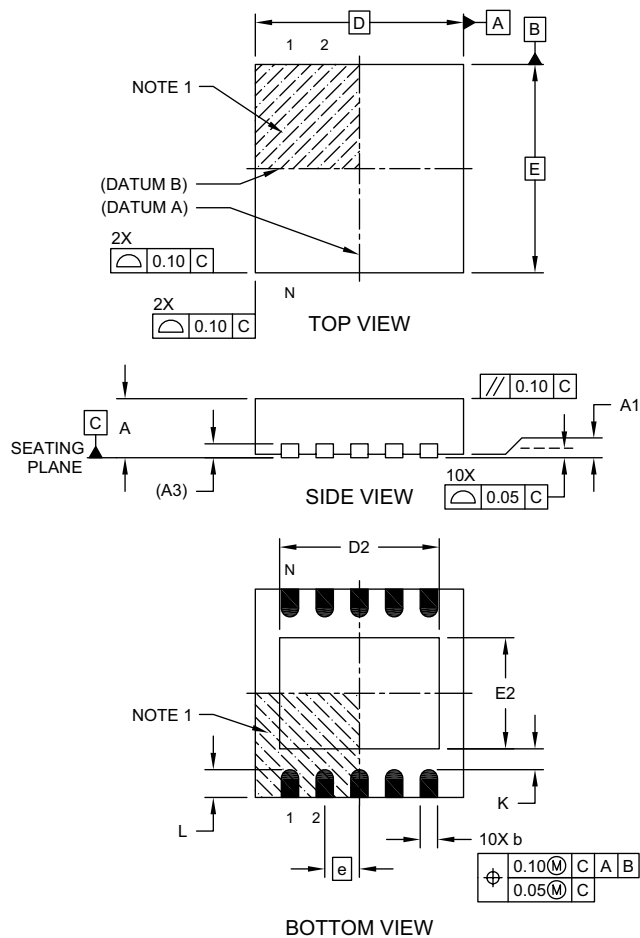

Microchip Technology Drawing C04-206A Sheet 1 of 2

© 2017 Microchip Technology Incorporated

MIC2204

10-Lead VDFN (ML) Recommended Land Pattern



10-Lead Very Thin Plastic Dual Flat, No Lead Package (9Q) - 3x3 mm Body [VDFN]

Note: For the most current package drawings, please see the Microchip Packaging Specification located at <http://www.microchip.com/packaging>

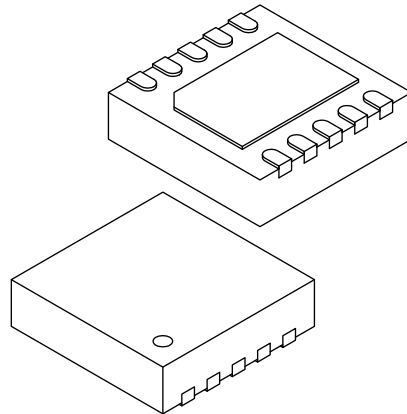

Dimension Limits	Units	MILLIMETERS		
		MIN	NOM	MAX
Number of Terminals	N	10		
Pitch	e	0.50 BSC		
Overall Height	A	0.80	0.85	0.90
Standoff	A1	0.00	0.02	0.05
Terminal Thickness	(A3)	0.20 REF		
Overall Length	D	3.00 BSC		
Exposed Pad Length	D2	2.20	2.30	2.40
Overall Width	E	3.00 BSC		
Exposed Pad Width	E2	1.50	1.60	1.70
Terminal Width	b	0.18	0.25	0.30
Terminal Length	L	0.35	0.40	0.45
Terminal-to-Exposed-Pad	K	0.25	0.30	-

Notes:

1. Pin 1 visual index feature may vary, but must be located within the hatched area.
2. Package is saw singulated
3. Dimensioning and tolerancing per ASME Y14.5M

BSC: Basic Dimension. Theoretically exact value shown without tolerances.

REF: Reference Dimension, usually without tolerance, for information purposes only.

Microchip Technology Drawing C04-206A Sheet 2 of 2

10-Lead VDFN (ML) Recommended Land Pattern



10-Lead Very Thin Plastic Dual Flat, No Lead Package (9Q) - 3x3 mm Body [VDFN]

Note: For the most current package drawings, please see the Microchip Packaging Specification located at <http://www.microchip.com/packaging>

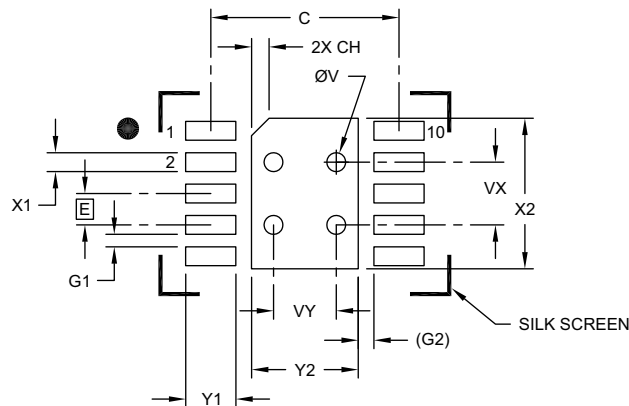

RECOMMENDED LAND PATTERN

Dimension	Units		MILLIMETERS		
	Dimension	Limits	MIN	NOM	MAX
Contact Pitch	E		0.50 BSC		
Optional Center Pad Width	Y2				1.70
Optional Center Pad Length	X2				2.40
Contact Pad Spacing	C		3.00		
Center Pad Chamfer	CH		0.28		
Contact Pad Width (X10)	X1				0.30
Contact Pad Length (X10)	Y1				0.80
Contact Pad to Contact Pad (X8)	G1	0.20			
Contact Pad to Center Pad (X10)	G2		0.25 REF		
Thermal Via Diameter	V		0.30		
Thermal Via Pitch	VX		1.00		
Thermal Via Pitch	VY		1.00		

Notes:

- Dimensioning and tolerancing per ASME Y14.5M
 BSC: Basic Dimension. Theoretically exact value shown without tolerances.
 REF: Reference Dimension, usually without tolerances, for reference only.
- For best soldering results, thermal vias, if used, should be filled or tented to avoid solder loss during reflow process

Microchip Technology Drawing C04-2206A

MIC2204

NOTES:

APPENDIX A: REVISION HISTORY

Revision A (December 2020)

- Converted Micrel document MIC2204 to Microchip data sheet DS20006454A.
- Minor text changes throughout.

MIC2204

NOTES:

PRODUCT IDENTIFICATION SYSTEM

To order or obtain information, e.g., on pricing or delivery, contact your local Microchip representative or sales office.

<u>PART NO.</u>	<u>X</u>	<u>XX</u>	<u>-XX</u>
Device	Junction Temperature Range	Package	Media Type
Device: Junction Temperature Range: Package: Media Type:	MIC2204: High-Efficiency 2 MHz Synchronous Buck Converter with Adjustable Output Voltage Y = -40°C to +125°C	ML = 10-Lead VDFN, 3 mm x 3 mm x 0.9 mm MM = 10-Lead MSOP	Blank = 100/Tube (MSOP) Blank = 100/Tube (VDFN) Blank = 2,500/Reel (MSOP) Blank = 5,000/Reel (VDFN)
Examples: a) MIC2204YML: 2 MHz Synchronous Buck Converter, Adjustable Output Voltage, -40°C to +125°C Junction Temp. Range, RoHS Compliant, 10-Lead 3 mm x 3 mm x 0.9 mm VDFN Package, 100/Tube b) MIC2204YML-TR: 2 MHz Synchronous Buck Converter, Adjustable Output Voltage, -40°C to +125°C Junction Temp. Range, RoHS Compliant, 10-Lead 3 mm x 3 mm x 0.9 mm VDFN Package, 5,000/Reel c) MIC2204YMM: 2 MHz Synchronous Buck Converter, Adjustable Output Voltage, -40°C to +125°C Junction Temp. Range, RoHS Compliant, 10-Lead MSOP Package, 100/Tube d) MIC2204YMM-TR: 2 MHz Synchronous Buck Converter, Adjustable Output Voltage, -40°C to +125°C Junction Temp. Range, RoHS Compliant, 10-Lead MSOP Package, 2,500/Reel Note 1: Tape and Reel identifier only appears in the catalog part number description. This identifier is used for ordering purposes and is not printed on the device package. Check with your Microchip Sales Office for package availability with the Tape and Reel option.			

MIC2204

NOTES:

Note the following details of the code protection feature on Microchip devices:

- Microchip products meet the specifications contained in their particular Microchip Data Sheet.
- Microchip believes that its family of products is secure when used in the intended manner and under normal conditions.
- There are dishonest and possibly illegal methods being used in attempts to breach the code protection features of the Microchip devices. We believe that these methods require using the Microchip products in a manner outside the operating specifications contained in Microchip's Data Sheets. Attempts to breach these code protection features, most likely, cannot be accomplished without violating Microchip's intellectual property rights.
- Microchip is willing to work with any customer who is concerned about the integrity of its code.
- Neither Microchip nor any other semiconductor manufacturer can guarantee the security of its code. Code protection does not mean that we are guaranteeing the product is "unbreakable." Code protection is constantly evolving. We at Microchip are committed to continuously improving the code protection features of our products. Attempts to break Microchip's code protection feature may be a violation of the Digital Millennium Copyright Act. If such acts allow unauthorized access to your software or other copyrighted work, you may have a right to sue for relief under that Act.

Information contained in this publication is provided for the sole purpose of designing with and using Microchip products. Information regarding device applications and the like is provided only for your convenience and may be superseded by updates. It is your responsibility to ensure that your application meets with your specifications.

THIS INFORMATION IS PROVIDED BY MICROCHIP "AS IS". MICROCHIP MAKES NO REPRESENTATIONS OR WARRANTIES OF ANY KIND WHETHER EXPRESS OR IMPLIED, WRITTEN OR ORAL, STATUTORY OR OTHERWISE, RELATED TO THE INFORMATION INCLUDING BUT NOT LIMITED TO ANY IMPLIED WARRANTIES OF NON-INFRINGEMENT, MERCHANTABILITY, AND FITNESS FOR A PARTICULAR PURPOSE OR WARRANTIES RELATED TO ITS CONDITION, QUALITY, OR PERFORMANCE.

IN NO EVENT WILL MICROCHIP BE LIABLE FOR ANY INDIRECT, SPECIAL, PUNITIVE, INCIDENTAL OR CONSEQUENTIAL LOSS, DAMAGE, COST OR EXPENSE OF ANY KIND WHATSOEVER RELATED TO THE INFORMATION OR ITS USE, HOWEVER CAUSED, EVEN IF MICROCHIP HAS BEEN ADVISED OF THE POSSIBILITY OR THE DAMAGES ARE FORESEEABLE. TO THE FULLEST EXTENT ALLOWED BY LAW, MICROCHIP'S TOTAL LIABILITY ON ALL CLAIMS IN ANY WAY RELATED TO THE INFORMATION OR ITS USE WILL NOT EXCEED THE AMOUNT OF FEES, IF ANY, THAT YOU HAVE PAID DIRECTLY TO MICROCHIP FOR THE INFORMATION. Use of Microchip devices in life support and/or safety applications is entirely at the buyer's risk, and the buyer agrees to defend, indemnify and hold harmless Microchip from any and all damages, claims, suits, or expenses resulting from such use. No licenses are conveyed, implicitly or otherwise, under any Microchip intellectual property rights unless otherwise stated.

Trademarks

The Microchip name and logo, the Microchip logo, Adaptec, AnyRate, AVR, AVR logo, AVR Freaks, BesTime, BitCloud, chipKIT, chipKIT logo, CryptoMemory, CryptoRF, dsPIC, FlashFlex, flexPWR, HELDO, IGL00, JukeBlox, KeeLoq, Klear, LANCheck, LinkMD, maXStylus, maXTouch, MediaLB, megaAVR, Microsemi, Microsemi logo, MOST, MOST logo, MPLAB, OptoLyzr, PackeTime, PIC, picoPower, PICSTART, PIC32 logo, PolarFire, Prochip Designer, QTouch, SAM-BA, SenGenuity, SpyNIC, SST, SST Logo, SuperFlash, Symmetricom, SyncServer, Tachyon, TimeSource, tinyAVR, UNI/O, Vectron, and XMEGA are registered trademarks of Microchip Technology Incorporated in the U.S.A. and other countries.

AgileSwitch, APT, ClockWorks, The Embedded Control Solutions Company, EtherSynch, FlashTec, Hyper Speed Control, HyperLight Load, IntelliMOS, Libero, motorBench, mTouch, Powermite 3, Precision Edge, ProASIC, ProASIC Plus, ProASIC Plus logo, Quiet-Wire, SmartFusion, SyncWorld, Temux, TimeCesium, TimeHub, TimePictra, TimeProvider, WinPath, and ZL are registered trademarks of Microchip Technology Incorporated in the U.S.A.

Adjacent Key Suppression, AKS, Analog-for-the-Digital Age, Any Capacitor, AnyIn, AnyOut, Augmented Switching, BlueSky, BodyCom, CodeGuard, CryptoAuthentication, CryptoAutomotive, CryptoCompanion, CryptoController, dsPICDEM, dsPICDEM.net, Dynamic Average Matching, DAM, ECAN, Espresso T1S, EtherGREEN, IdealBridge, In-Circuit Serial Programming, ICSP, INICnet, Intelligent Paralleling, Inter-Chip Connectivity, JitterBlocker, maxCrypto, maxView, memBrain, Mindi, MiWi, MPASM, MPF, MPLAB Certified logo, MPLIB, MPLINK, MultiTRAK, NetDetach, Omniscient Code Generation, PICDEM, PICDEM.net, PICkit, PICtail, PowerSmart, PureSilicon, QMatrix, REAL ICE, Ripple Blocker, RTAX, RTG4, SAM-ICE, Serial Quad I/O, simpleMAP, SimpliPHY, SmartBuffer, SMART-I.S., storClad, SQI, SuperSwitcher, SuperSwitcher II, Switchtec, SynchroPHY, Total Endurance, TSHARC, USBCheck, VariSense, VectorBlox, VeriPHY, ViewSpan, WiperLock, XpressConnect, and ZENA are trademarks of Microchip Technology Incorporated in the U.S.A. and other countries.

SQTP is a service mark of Microchip Technology Incorporated in the U.S.A.

The Adaptec logo, Frequency on Demand, Silicon Storage Technology, and Symmcom are registered trademarks of Microchip Technology Inc. in other countries.

GestIC is a registered trademark of Microchip Technology Germany II GmbH & Co. KG, a subsidiary of Microchip Technology Inc., in other countries.

All other trademarks mentioned herein are property of their respective companies.

© 2020, Microchip Technology Incorporated, All Rights Reserved.

ISBN: 978-1-5224-7351-0

For information regarding Microchip's Quality Management Systems, please visit www.microchip.com/quality.



MICROCHIP

Worldwide Sales and Service

AMERICAS

Corporate Office
2355 West Chandler Blvd.
Chandler, AZ 85224-6199
Tel: 480-792-7200
Fax: 480-792-7277
Technical Support:
<http://www.microchip.com/support>
Web Address:
www.microchip.com

Atlanta

Duluth, GA
Tel: 678-957-9614
Fax: 678-957-1455

Austin, TX

Tel: 512-257-3370

Boston

Westborough, MA
Tel: 774-760-0087
Fax: 774-760-0088

Chicago

Itasca, IL
Tel: 630-285-0071
Fax: 630-285-0075

Dallas

Addison, TX
Tel: 972-818-7423
Fax: 972-818-2924

Detroit

Novi, MI
Tel: 248-848-4000

Houston, TX

Tel: 281-894-5983

Indianapolis

Noblesville, IN
Tel: 317-773-8323
Fax: 317-773-5453
Tel: 317-536-2380

Los Angeles

Mission Viejo, CA
Tel: 949-462-9523
Fax: 949-462-9608
Tel: 951-273-7800

Raleigh, NC

Tel: 919-844-7510

New York, NY

Tel: 631-435-6000

San Jose, CA

Tel: 408-735-9110
Tel: 408-436-4270

Canada - Toronto

Tel: 905-695-1980
Fax: 905-695-2078

ASIA/PACIFIC

Australia - Sydney
Tel: 61-2-9868-6733

China - Beijing
Tel: 86-10-8569-7000

China - Chengdu
Tel: 86-28-8665-5511

China - Chongqing
Tel: 86-23-8980-9588

China - Dongguan
Tel: 86-769-8702-9880

China - Guangzhou
Tel: 86-20-8755-8029

China - Hangzhou
Tel: 86-571-8792-8115

China - Hong Kong SAR
Tel: 852-2943-5100

China - Nanjing
Tel: 86-25-8473-2460

China - Qingdao
Tel: 86-532-8502-7355

China - Shanghai
Tel: 86-21-3326-8000

China - Shenyang
Tel: 86-24-2334-2829

China - Shenzhen
Tel: 86-755-8864-2200

China - Suzhou
Tel: 86-186-6233-1526

China - Wuhan
Tel: 86-27-5980-5300

China - Xian
Tel: 86-29-8833-7252

China - Xiamen
Tel: 86-592-2388138

China - Zhuhai
Tel: 86-756-3210040

ASIA/PACIFIC

India - Bangalore
Tel: 91-80-3090-4444

India - New Delhi
Tel: 91-11-4160-8631

India - Pune
Tel: 91-20-4121-0141

Japan - Osaka
Tel: 81-6-6152-7160

Japan - Tokyo
Tel: 81-3-6880-3770

Korea - Daegu
Tel: 82-53-744-4301

Korea - Seoul
Tel: 82-2-554-7200

Malaysia - Kuala Lumpur
Tel: 60-3-7651-7906

Malaysia - Penang
Tel: 60-4-227-8870

Philippines - Manila
Tel: 63-2-634-9065

Singapore
Tel: 65-6334-8870

Taiwan - Hsin Chu
Tel: 886-3-577-8366

Taiwan - Kaohsiung
Tel: 886-7-213-7830

Taiwan - Taipei
Tel: 886-2-2508-8600

Thailand - Bangkok
Tel: 66-2-694-1351

Vietnam - Ho Chi Minh
Tel: 84-28-5448-2100

EUROPE

Austria - Wels
Tel: 43-7242-2244-39
Fax: 43-7242-2244-393

Denmark - Copenhagen
Tel: 45-4485-5910
Fax: 45-4485-2829

Finland - Espoo
Tel: 358-9-4520-820

France - Paris
Tel: 33-1-69-53-63-20
Fax: 33-1-69-30-90-79

Germany - Garching
Tel: 49-8931-9700

Germany - Haan
Tel: 49-2129-3766400

Germany - Heilbronn
Tel: 49-7131-72400

Germany - Karlsruhe
Tel: 49-721-625370

Germany - Munich
Tel: 49-89-627-144-0
Fax: 49-89-627-144-44

Germany - Rosenheim
Tel: 49-8031-354-560

Israel - Ra'anana
Tel: 972-9-744-7705

Italy - Milan
Tel: 39-0331-742611
Fax: 39-0331-466781

Italy - Padova
Tel: 39-049-7625286

Netherlands - Drunen
Tel: 31-416-690399
Fax: 31-416-690340

Norway - Trondheim
Tel: 47-7288-4388

Poland - Warsaw
Tel: 48-22-3325737

Romania - Bucharest
Tel: 40-21-407-87-50

Spain - Madrid
Tel: 34-91-708-08-90
Fax: 34-91-708-08-91

Sweden - Gothenberg
Tel: 46-31-704-60-40

Sweden - Stockholm
Tel: 46-8-5090-4654

UK - Wokingham
Tel: 44-118-921-5800
Fax: 44-118-921-5820