



# LSM1208472V Series

## 1208 SMD LED Package

### 3.0x2.0x1.3 mm SMD Chip LED



**LSM1208472V Yellow SMD LED. Low Profile Surface Mount LED**

#### Application

- Automotive Dashboards
- Backlighting
- Wearable and Portable Devices
- Tail Lights
- Status Indicators
- Navigation Systems
- Medical Devices
- Home and Smart Appliance
- Status Indicator

#### Key Features

- 3.0 x 2.0 mm (1208 package/3020 metric) Chip SMD LED
- 1.3 mm in thickness
- Wide viewing angle (120°)
- Cost-efficient solution for low-power and compact electronic equipment designs
- Ideal for special configurations for automated PC board assembly and space-sensitive applications
- Water clear lens
- Compatible with infrared and vapor phase reflow solder process
- Compatible with automatic placement equipment
- Moisture sensitivity level: MSL 5A
- Package 2,000 pieces per reel
- Compliant with RoHS

## Product Dimensions

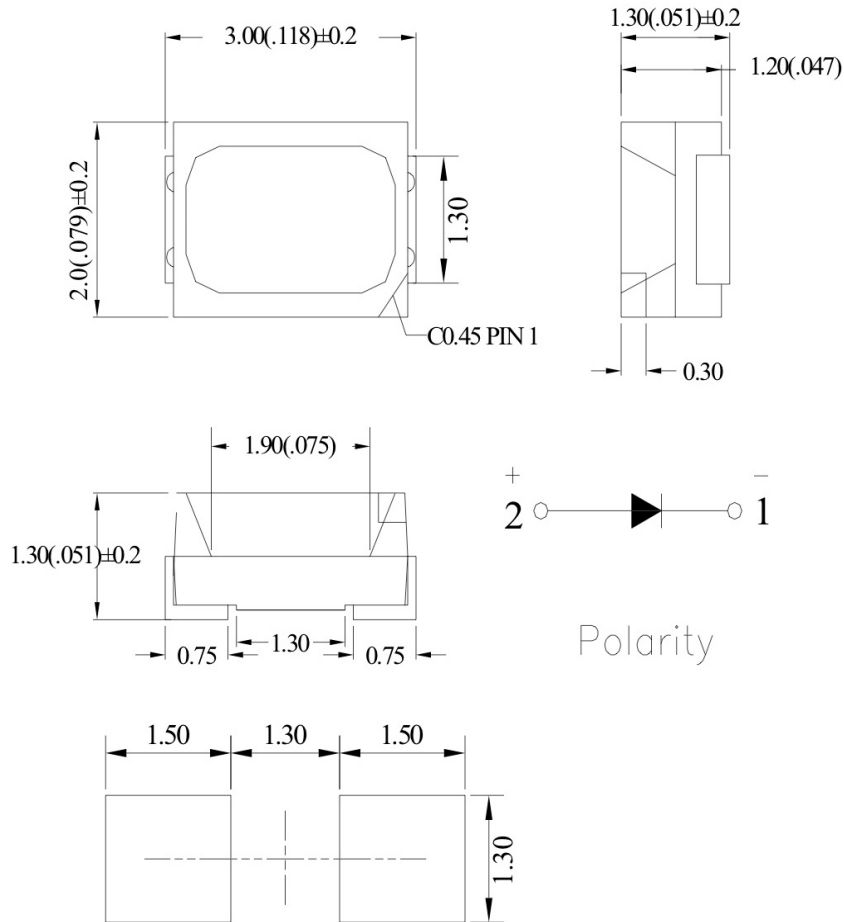

### Notes:

1. All dimensions are in millimeters (inches)
2. Tolerance is  $\pm 0.1$  mm [0.004 in] unless otherwise noted
3. The specifications, characteristics and technical data described in the datasheet are subject to change without prior notice.

## Product Specifications

### Absolute Maximum Ratings (Ta=25°C)

Parameter	Symbol	Rating	Unit
Power Dissipation	Pd	75	mW
Forward Current	I <sub>F</sub>	30	mA
Peak Forward Current * 1	I <sub>FP</sub>	100	mA
Operating Temperature	Topr	-40°C~85°C	-
Storage Temperature	Tstg	-40°C~100°C	-
Soldering Temperature	Tsol	See Page 5	-

\* 1 Condition for I<sub>FP</sub> is pulse of 1/10 duty and 3 msec width.

# Product Specifications

## Electrical and optical characteristics(Ta=25°C)

Parameter	Symbol	Condition	Min.	Typ.	Max.	Unit
Forward Voltage	V <sub>f</sub>	I <sub>F</sub> =20mA	-	2.1	2.6	V
Luminous Intensity	I <sub>v</sub>	I <sub>F</sub> =20mA	-	18	-	mcd
Peak Wave Length	λ <sub>p</sub>	I <sub>F</sub> =20mA	-	590	-	nm
Dominant Wave Length	λ <sub>d</sub>	I <sub>F</sub> =20mA	586	-	594	nm
Spectral Line Half-width	Δλ	I <sub>F</sub> =20mA	-	15	-	nm
Reverse Current	I <sub>R</sub>	V <sub>R</sub> =5V	-	-	10	μA
Veiwng Angle	2θ <sub>1/2</sub>	I <sub>F</sub> =20mA	-	120	-	deg

## Typical Electro-Optical Characteristics Curves

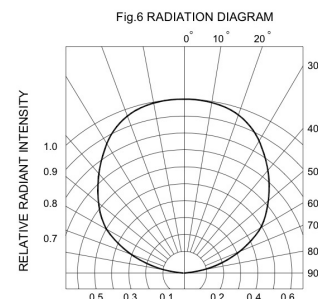
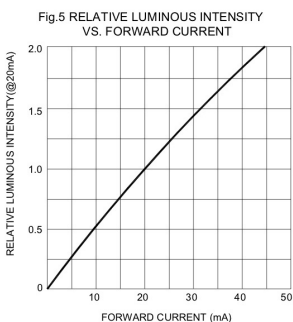
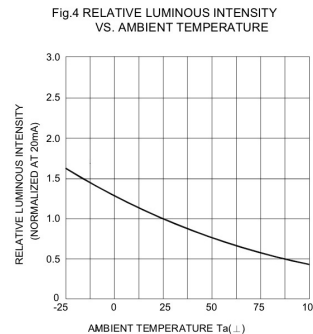
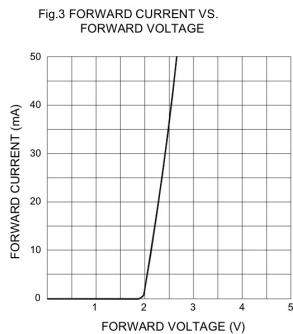
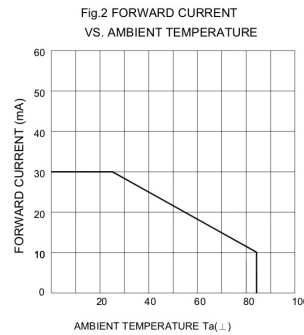
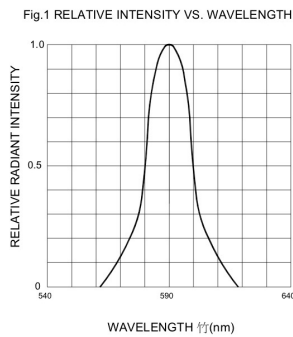

## Reliability Data

### Reliability Test

Classification	Test Item	Reference Standard	Test Conditions	Result
Endurance Test	Operation Life	MIL-STD-750:1026 MIL-STD-883:1005 JIS-C-7021 :B-1	Connect with a power $I_f=20\text{mA}$ $T_a$ =Under room temperature Test time=1,000hrs	0/20
	High Temperature High Humidity Storage	MIL-STD-202:103B JIS-C-7021 :B-11	$T_a=+65^\circ\text{C}\pm 5^\circ\text{C}$ RH=90%-95% Test time=240hrs	0/20
	High Temperature Storage	MIL-STD-883:1008 JIS-C-7021 :B-10	High $T_a=+85^\circ\text{C}\pm 5^\circ\text{C}$ Test time=1,000hrs	0/20
	Low Temperature Storage	JIS-C-7021 :B-12	Low $T_a=-35^\circ\text{C}\pm 5^\circ\text{C}$ Test time=1,000hrs	0/20
Environmental Test	Temperature Cycling	MIL-STD-202:107D MIL-STD-750:1051 MIL-STD-883:1010 JIS-C-7021 :A-4	$-35^\circ\text{C} \sim +25^\circ\text{C} \sim +85^\circ\text{C} \sim +25^\circ\text{C}$ 60min 20min 60min 20min Test Time=5cycle	0/20
	Thermal Shock	MIL-STD-202:107D MIL-STD-750:1051 MIL-STD-883:1011	$-35^\circ\text{C}\pm 5^\circ\text{C} \sim +85^\circ\text{C}\pm 5^\circ\text{C}$ 20min 20min Test Time=10cycle	0/20
	Solder Resistance	MIL-STD-202:201A MIL-STD-750:2031 JIS-C-7021 :A-1	Preheating : 140°C-160°C, within 2 minutes. Operation heating : 235°C (Max.), within 10seconds. (Max.)	0/20

### Judgment criteria of failure for the reliability

Measuring items	Symbol	Measuring conditions	Judgement criteria for failure
Forward voltage	$V_F$ ( V )	$I_F=20\text{mA}$	Over $U_x1.2$
Reverse current	$I_R$ ( $\mu\text{A}$ )	$V_R=5\text{V}$	Over $U_x2$
Luminous intensity	$I_v$ ( mcd )	$I_F=20\text{mA}$	Below $SX0.5$

#### Notes:

1. U means the upper limit specified characteristics. S means initial value.
2. Measurement shall be taken between 2 hours and after the test pieces have been returned to normal ambient conditions after completion of each test.

## Recommended Reflow Soldering Profile

### IR-Reflow

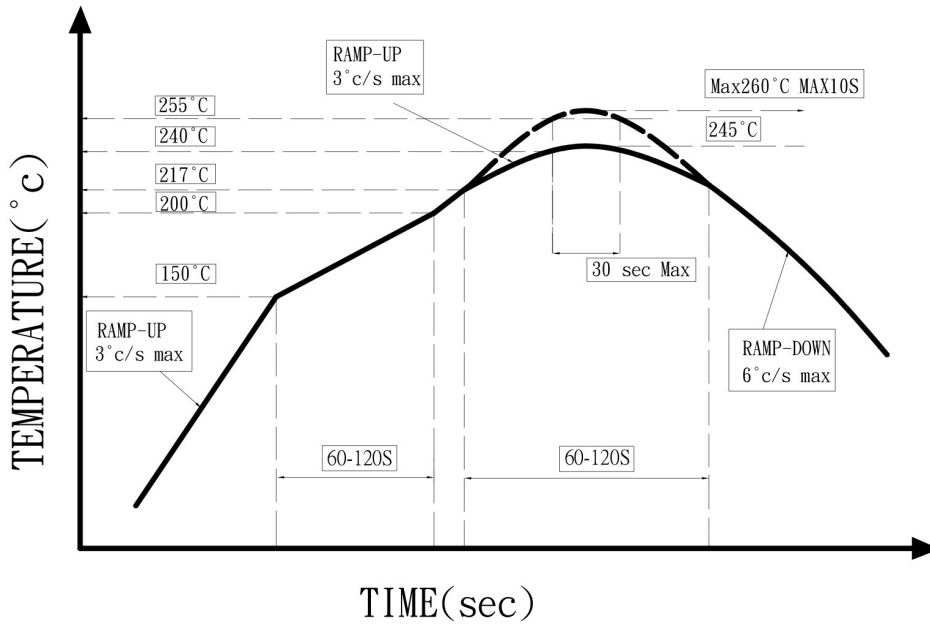

1. Avoid any external stress applied to the resin while the LEDs are at high temperature, especially during soldering.
2. Avoid rapid cooling or any excess vibration during temperature ramp-down process
3. Although the soldering condition is recommended above, soldering at the lowest possible temperature is feasible for the LEDs

### Iron Soldering

350°C within 3 Sec, one time only

## Precautions

### Handling Precautions

Compare to epoxy encapsulant that is hard and brittle, silicone is softer and flexible. Although its characteristic significantly reduces thermal stress, it is more susceptible to damage by external mechanical force. As a result, special handling precautions need to be observed during assembly using silicone encapsulated LED products. Failure to comply might lead to damage and premature failure of the LED.

1. Handle the component along the side surfaces by using forceps or appropriate tools. (pic.1)
2. Do not directly touch or handle the silicone lens surface. It may damage the internal circuitry. (pic.2, pic.3)
3. Do not stack together assembled PCBs, containing exposed LEDs. The impact may scratch the silicone lens or damage the internal circuitry. (pic.4)
4. The outer diameter of the SMD pickup nozzle should not exceed the size of the LED to prevent air leaks. The inner diameter of the nozzle should be as large as possible. (pic.5)
5. A pliable material is suggested for the nozzle tip to avoid scratching or damaging the LED surface during pickup. (pic.5)
6. The dimensions of the component must be accurately programmed in the pick-and-place machine to insure precise pickup and avoid damage during production. (pic.5)

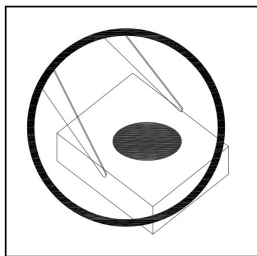

**Pic.1**

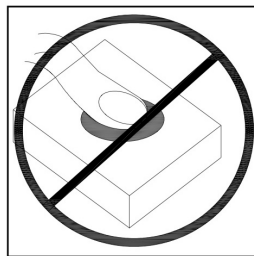

**Pic.2**

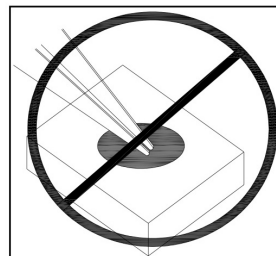

**Pic.3**

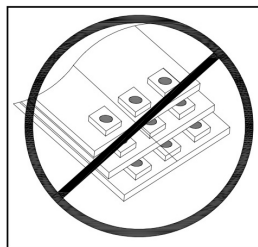

**Pic.4**

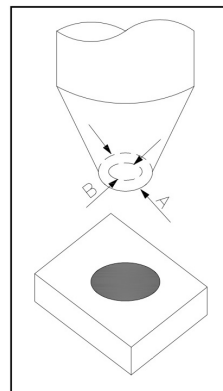

**Pic.5**

## Precautions

### Notes for designing:

Care must be taken to provide the current limiting resistor in the circuit to drive the LEDs within the rated figures. Also, caution should be taken not to overload LEDs with the instantaneous voltage at the turning ON and OFF of the circuit.

When using the pulse drive care must be taken to keep the average current within the rated figures. Also, the circuit should be designed to be subjected to reverse voltage when turning off the LEDs.

### Storage:

To avoid the absorption of moisture, it is recommended to solder LEDs as soon as possible after unpacking the sealed envelope. If the envelope is still packed, to store it in the environment as follows:

- (1) Temperature: 5°C-30°C(41°F) Humidity: RH 60% Max.
- (2) After this bag is opened, devices that will be applied to infrared reflow, vapor-phase reflow or equivalent soldering process must be:
  - a. Completed within 24 hours.
  - b. Stored at less than 20% RH.
- (3) Devices require baking before mounting, if: 2a or 2b is not met.
- (4) If baking is required, devices must be baked under below conditions: 48 hours at 60°C±5°C.

## Tape and Reel Specifications

Package: Products are packed in one bag of 2000pcs (one taping reel) and a label is attached on each bag.

### Tapping and packaging specifications (Units: mm)

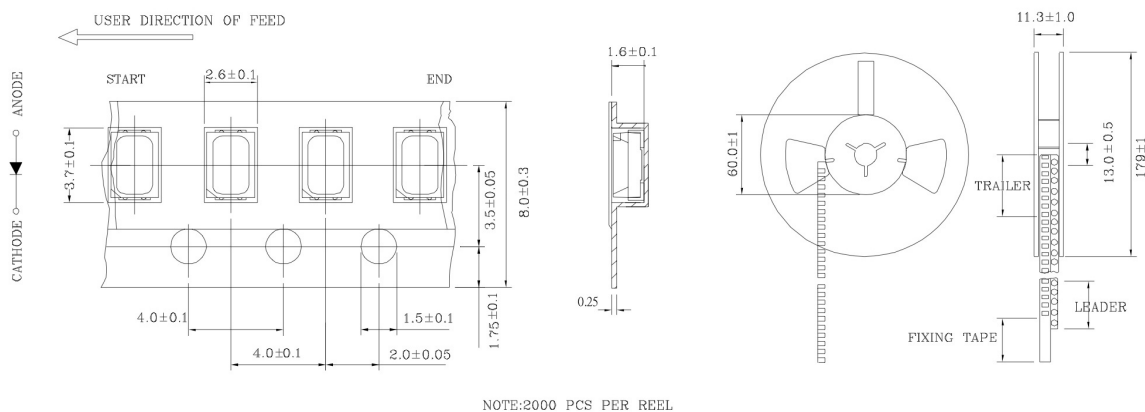

## Compliances and Approvals

