

## 【1. 適用範囲 SCOPE】

本仕様書は、\_\_\_\_\_ 殿 に納入する

Mini-Lock 2.5 電線対基板用 コネクタ スルーホールタイプ / SMTタイプ \_\_\_\_\_ について規定する。

This product specification covers the performance requirements for Mini-Lock 2.5 WIRE TO BOARD CONNECTOR Through Hole type / SMT type series for limited use by \_\_\_\_\_ .

## 【2. 製品名称及び型番 PRODUCT NAME AND PART NUMBER】

製品名称 Product Name			製品型番 Part Number
リセプタクル Receptacle	ハウジング (リテーナー対応) Housing (Corresponds to Retainer)	色 : ナチュラル Color : Natural	51163**00 <sup>(※1)</sup>
	ターミナル (リテーナー対応) Terminal(Corresponds to Retainer)	AWG#20-#22	507528200
		AWG#24-#26	507528400
リテーナー (リセプタクルハウジング対応) Retainer(Corresponds to Receptacle Housing)			51164**05 <sup>(※1)</sup>
プラグ アセンブリ スルーホールタイプ Plug Assembly Through Hole Type	バーティカルタイプ Vertical Type	色 : ナチュラル Color : Natural	53375**10
		色 : ナチュラル Color : Natural	53476**10 <sup>(※1)</sup>
	バーティカルタイプ ポッティング対応 Vertical Type Potting	色 : ナチュラル Color : Natural	53517**30 <sup>(※1)</sup>
		色 : ナチュラル Color : Natural	53426**10
	ライトアングルタイプ Right Angle Type	色 : ナチュラル Color : Natural	534269**0 <sup>(※1)</sup>
プラグ アセンブリ SMTタイプ Plug Assembly SMT Type	バーティカルタイプ Vertical Type	色 : ナチュラル Color : Natural	215931**70 <sup>(※1)</sup>
		色 : 黒 Color : Black	215931**71 <sup>(※1)</sup>
	ライトアングルタイプ Right Angle Type	色 : ナチュラル Color : Natural	215932**70 <sup>(※1)</sup>
		色 : 黒 Color : Black	215932**71 <sup>(※1)</sup>

\* : 図面参照 Refer to the drawing

取扱についてはコネクタ取扱説明書” 2166940000-AS PS 000を参照願います。

Application specification : Refer to 2169940000-AS PS 000

(※1) : Glow wire test適合品

Glow wire test compatible

EN 60695-2-11-2001 / IEC 60695-2-11-2000のGlow Wire Testに準拠していることを確認しています。

They were tested and found compliant with EN 60695-2-11-2001 / IEC 60695-2-11-2000 Glow Wire Test Methods.

THIS DOCUMENT CONTAINS INFORMATION THAT IS PROPRIETARY TO MOLEX ELECTRONIC TECHNOLOGIES, LLC AND SHOULD NOT BE USED WITHOUT WRITTEN PERMISSION

REVISION DESCRIPTION	REVISED	MINI-LOCK 2.5 W/B CONNECTOR						
CHANGE NO.	728459							
REVISED BY	RWATANABE01	DATE	2022/11/15	DOC TYPE	DOC TYPE DESCRIPTION	DOC PART	SERIES	
REV APPR BY	SAKIYAMA	DATE	2022/11/17	PS	ENGINEERING SPECIFICATION WORD	000	51163	
INITIAL RELEASE			CUSTOMER		DOCUMENT NUMBER		REVISION	SHEET
INITIAL DRWN	RWATANABE01	DATE	2018/09/07	GENERAL	511630000-PS	G	1 OF 21	
INITIAL APPR	TKANEKO	DATE	2018/09/10					

**【3. 定格及び適合電線 RATINGS AND APPLICABLE WIRES】**

項目 Item	規格 Standard	
最大許容電圧 Allowable Voltage (MAX.)	250 V [ AC (実効値 rms) / DC ]	
最大許容電流 及び 適合電線 Allowable Current ( MAX. ) And Applicable wires	AWG#20	3.5 A
	AWG#22	3.0 A
	AWG#24	2.5 A
	AWG#26	2.0 A
使用温度範囲*1*2*3 Ambient Temperature Range	-55°C ~ +105°C 低温において氷結しないこと Not freeze in low temperature	

- \*1: 基板実装後の無通電状態は、使用温度範囲が適用されます。  
Non-operating connectors after reflow must follow the operating temperature range condition.
- \*2: 通電による温度上昇分を含む。  
This includes the terminal temperature rise generated by conducting electricity.
- \*3: 適合電線も本使用温度範囲を満足すること。  
Applicable wires must also meet the specified temperature range.

**参考許容電流 CURRENT DERATING REFERENCE INFORMATION**

AWG	2-circuits	7-circuits	15-circuits
	Amps (A)	Amps (A)	Amps (A)
20	5.0	3.5	3.5
22	4.5	3.0	3.0
24	4.0	2.5	2.5
26	3.5	2.5	2.0

- 1) 各電流値は参考となります。  
Values are for REFERENCE ONLY
- 2) 閾値は温度上昇30°C以下としています。  
Current deratings are based on not exceeding 30 °C Temperature Rise.
- 3) 温度上昇の測定は圧着端子のバレル部にて実施しています。  
Temperature Rise is measured in barrel area of crimp terminal.
- 4) 基板デザインにより温度上昇の結果が異なります。  
PCB trace design can greatly affect temperature rise results.
- 5) 全極に通電し測定しています。  
Data is for all circuits powered.

THIS DOCUMENT CONTAINS INFORMATION THAT IS PROPRIETARY TO MOLEX ELECTRONIC TECHNOLOGIES, LLC AND SHOULD NOT BE USED WITHOUT WRITTEN PERMISSION

REVISION DESCRIPTION	REVISED	<b>MINI-LOCK 2.5 W/B CONNECTOR</b>					
CHANGE NO.	728459						
REVISED BY	RWATANABE01	DATE	2022/11/15	DOC TYPE	DOC TYPE DESCRIPTION	DOC PART	SERIES
REV APPR BY	SAKIYAMA	DATE	2022/11/17	PS	ENGINEERING SPECIFICATION WORD	000	51163
INITIAL RELEASE				CUSTOMER	DOCUMENT NUMBER	REVISION	SHEET
INITIAL DRWN	RWATANABE01	DATE	2018/09/07	GENERAL	<b>511630000-PS</b>	<b>G</b>	2 OF 21
INITIAL APPR	TKANEKO	DATE	2018/09/10				

## 【4. 性能 PERFORMANCE】

## 4-1. 電気的性能 Electrical performance

項目 Item		条件 Test Condition	規格 Requirement
4-1-1	接触抵抗 Contact Resistance	コネクタを嵌合させ、開放電圧 20mV以下、短絡電流 10mA 以下にて測定する。但し、電線部の導体抵抗は差し引く。接触抵抗測定箇所は項番8を参照のこと。 (JIS C5402-2-1)  Mate connectors and measured by dry circuit, 20 mV MAX., 10 mA.MAX. Except wire conductor resistance. Refer to paragraph 8 for Contact resistance measuring point. (JIS C5402-2-1)	20 milliohms MAX.
4-1-2	絶縁抵抗 Insulation Resistance	コネクタを嵌合させ、隣接するターミナル間及びターミナル、アース間に、DC 500Vを印加し測定する。 (JIS C5402-3-1/MIL-STD-202 試験法 302)  Mate connectors and apply 500 V DC between adjacent terminal or ground. (JIS C5402-3-1/MIL-STD-202 Method 302)	1000 Megohms MIN.
4-1-3	耐電圧 Dielectric Strength	コネクタを嵌合させ、隣接するターミナル間及びターミナル、アース間に、AC 1000V (実効値) を1分間 印加する (JIS C5402-4-1/MIL-STD-202 試験法 301)  Mate connectors and apply 1,000 V AC(rms) for 1 minute between adjacent terminal or ground. (JIS C5402-4-1/MIL-STD-202 Method 301)	製品機能を損なう異常なきこと No Damage on function
4-1-4	圧着部接触抵抗 Contact Resistance on Crimped Portion	ターミナルに適合電線を圧着し、開放電圧20mV以下、短絡電流 10mA 以下にて測定する。  Crimp the applicable wire to the terminal, measured by dry circuit, 20 mV MAX., 10 mA.MAX.	5 milliohms MAX.

THIS DOCUMENT CONTAINS INFORMATION THAT IS PROPRIETARY TO MOLEX ELECTRONIC TECHNOLOGIES, LLC AND SHOULD NOT BE USED WITHOUT WRITTEN PERMISSION

REVISION DESCRIPTION	REVISED			MINI-LOCK 2.5 W/B CONNECTOR			
CHANGE NO.	728459						
REVISED BY	RWATANABE01	DATE	2022/11/15	DOC TYPE	DOC TYPE DESCRIPTION	DOC PART	SERIES
REV APPR BY	SAKIYAMA	DATE	2022/11/17	PS	ENGINEERING SPECIFICATION WORD	000	51163
INITIAL RELEASE				CUSTOMER	DOCUMENT NUMBER	REVISION	SHEET
INITIAL DRWN	RWATANABE01	DATE	2018/09/07	GENERAL	511630000-PS	G	3OF21
INITIAL APPR	TKANEKO	DATE	2018/09/10				

4-2. 機械的性能 Mechanical Performance

項 目 Item		条 件 Test Condition		規 格 Requirement
4-2-1	挿入力及び抜去力 Insertion and Withdrawal Force	手挿抜にて挿入、抜去を行う。 (但し、ロックは解除して行う) Insert and withdraw connectors with hand. (be measured with removing the lock)		第6項参照 Refer to section 6
4-2-2	圧着部引張強度 Crimping Pull out Force	圧着されたターミナルを治具に 固定し、電線を軸方向に 毎分25±3mmの速さで引張る。 (JIS C5402-16-4) Fix the crimped terminal to the jig, apply axial pull out force on the wire at the speed rate of 25 ±3 mm/minute. (JIS C5402-16-4)	AWG#20	49.0N{5.0kgf}MIN.
			AWG#22	39.2N{4.0kgf}MIN.
			AWG#24	29.4N{3.0kgf}MIN.
			AWG#26	19.6N{2.0kgf}MIN.
4-2-3	圧着端子挿入力 Crimp Terminal Insertion Force	圧着されたターミナルをハウジングに挿入する。 Insert the crimped terminal into the housing.		9.8N {1.0kgf} MAX.
4-2-4	圧着端子保持力 Crimp Terminal Retention Force	ハウジングに装着した圧着されたターミナルを 毎分 25±3mm の速さで軸方向に引張る。 Apply axial pull out force at the speed rate of 25 ±3 mm/minute on the crimped terminal assembled in the housing.		14.7N{1.5kgf}MIN.
4-2-5	プラグピン保持力 Plug Pin Retention Force	プラグハウジングに装着されたピンを毎分 25±3mmの速さで軸方向に引張る。 Apply axial pull out force at the speed rate of 25 ±3 mm/minute on the pin assembled in the plug housing.		[Through Hole Type] 14.7N {1.5kgf} MIN.  [SMT Type] 9.8N {1.0kgf} MIN.
4-2-6	ハウジングロック強度 (ポジティブロック) Housing Lock Strength ( Positive Lock )	コネクタを嵌合させ、軸方向に毎分25±3mmの 速さで引張る。 Mate connectors and apply axial pull out force at the speed rate of 25 ±3 mm/minute.		[2極(2ckt)] 19.6N {2.0kgf} MIN.  [3極以上(3ckt or more)] 29.4N {3.0kgf} MIN.
4-2-7	リテーナー装着力 Retainer Insertion Force	毎分25±3mmの速さでハウジングにリテーナーを装 着する。 Insert a retainer into a housing at the speed rate of 25 ±3 mm/minute.		4.9N {0.5kgf} MAX.

THIS DOCUMENT CONTAINS INFORMATION THAT IS PROPRIETARY TO MOLEX ELECTRONIC TECHNOLOGIES, LLC AND SHOULD NOT BE USED WITHOUT WRITTEN PERMISSION

REVISION DESCRIPTION	REVISED	<b>MINI-LOCK 2.5 W/B CONNECTOR</b>					
CHANGE NO.	728459						
REVISED BY	RWATANABE01	DATE	2022/11/15	DOC TYPE	DOC TYPE DESCRIPTION	DOC PART	SERIES
REV APPR BY	SAKIYAMA	DATE	2022/11/17	PS	ENGINEERING SPECIFICATION WORD	000	51163
INITIAL RELEASE				CUSTOMER	DOCUMENT NUMBER	REVISION	SHEET
INITIAL DRWN	RWATANABE01	DATE	2018/09/07	GENERAL	<b>511630000-PS</b>	<b>G</b>	4 OF 21
INITIAL APPR	TKANEKO	DATE	2018/09/10				

4-3. 環境性能、その他 Environmental Performance and Others

項目 Item		条件 Test Condition	規格 Requirement	
4-3-1	繰り返し挿抜 Repeated Insertion / Withdrawal	1分間 10回 以下の速さで、挿入、抜去を30回 繰り返す。 Insert and withdraw connectors 30 cycles repeatedly by rate of less than 10 cycles per minute.	接触抵抗 Contact Resistance	40 milliohms MAX.
4-3-2	温度上昇 Temperature Rise	コネクタを嵌合させ、全ての圧着端子を直列に接続し最大許容電流で熱平衡に達した時の温度上昇を測定する。(UL498) Mate connectors and all crimp terminals shall be connected in a direct series. The temperature rise shall be measured when the terminal reaches thermal equilibrium allowable current. (UL498)	温度上昇 Temperature Rise	30 °C MAX.
4-3-3	耐振動性 Vibration	コネクタを嵌合させ、DC 1mA 通電状態で、嵌合軸を含む互いに垂直な 3方向に 掃引割合 10~55~10 Hz/分、全振幅 1.5mm の振動を各2時間 加える。(ケーブルは固定すること) (JIS C 60068-2-6/MIL-STD-202 試験法 201) Mate connectors and subject to the following vibration conditions, for a period of 2 hours in each of 3 mutually perpendicular axes, passing DC 1mA during the test. (Fix the cable at test.) Amplitude : 1.5 mm P-P Frequency : 10~55~10 Hz in 1 minute. Duration : 2 hours in each X.Y.Z.axes. (JIS C 60068-2-6/MIL-STD-202 Method 201)	外観 Appearance	製品機能を損なう異常なきこと No Damage on function
			接触抵抗 Contact Resistance	40 milliohms MAX.
			瞬断 Discontinuity	1.0 micro second MAX.

THIS DOCUMENT CONTAINS INFORMATION THAT IS PROPRIETARY TO MOLEX ELECTRONIC TECHNOLOGIES, LLC AND SHOULD NOT BE USED WITHOUT WRITTEN PERMISSION

REVISION DESCRIPTION	REVISED	<b>MINI-LOCK 2.5 W/B CONNECTOR</b>					
CHANGE NO.	728459						
REVISED BY	RWATANABE01	DATE	2022/11/15	DOC TYPE	DOC TYPE DESCRIPTION	DOC PART	SERIES
REV APPR BY	SAKIYAMA	DATE	2022/11/17	PS	ENGINEERING SPECIFICATION WORD	000	51163
INITIAL RELEASE				CUSTOMER	DOCUMENT NUMBER	REVISION	SHEET
INITIAL DRWN	RWATANABE01	DATE	2018/09/07	GENERAL	<b>511630000-PS</b>	<b>G</b>	5 OF 21
INITIAL APPR	TKANEKO	DATE	2018/09/10				

項 目 Item		条 件 Test Condition	規 格 Requirement	
4-3-4	耐 衝 撃 性 Mechanical Shock	コネクタを嵌合させ、DC 1mA 通電状態にて、テストパルス半周期、嵌合軸を含む互いに垂直な 6方向 に 490m/s <sup>2</sup> { 50G }、作用時間11msの衝撃を各3回、合計18回加える。 (JIS C60068-2-27/MIL-STD-202 試験法 213)  Mate connectors and subject to the following shock conditions. 3 shocks shall be applied along 3 mutually perpendicular axes, passing DC 1 mA current during the test. (Total of 18 shocks) Test pulse : Half Sine Peak value : 490 m/s <sup>2</sup> (50 G) Duration : 11 ms (JIS C60068-2-27/MIL-STD-202 Method 213)	外 観 Appearance	製品機能を損なう異常なきこと No Damage on function
			接 触 抵 抗 Contact Resistance	40 milliohms MAX.
			瞬 断 Discontinuity	1.0 micro second MAX.

THIS DOCUMENT CONTAINS INFORMATION THAT IS PROPRIETARY TO MOLEX ELECTRONIC TECHNOLOGIES, LLC AND SHOULD NOT BE USED WITHOUT WRITTEN PERMISSION

REVISION DESCRIPTION	REVISED	<b>MINI-LOCK 2.5 W/B CONNECTOR</b>					
CHANGE NO.	728459						
REVISED BY	RWATANABE01	DATE	2022/11/15	DOC TYPE	DOC TYPE DESCRIPTION	DOC PART	SERIES
REV APPR BY	SAKIYAMA	DATE	2022/11/17	PS	ENGINEERING SPECIFICATION WORD	000	51163
INITIAL RELEASE				CUSTOMER	DOCUMENT NUMBER	REVISION	SHEET
INITIAL DRWN	RWATANABE01	DATE	2018/09/07	GENERAL	<b>511630000-PS</b>	<b>G</b>	6 OF 21
INITIAL APPR	TKANEKO	DATE	2018/09/10				

項目 Item		条件 Test Condition	規格 Requirement	
4-3-5	耐熱性 Heat Resistance	コネクタを嵌合させ、105±2°C の雰囲気中に96時間放置後取り出し、1~2時間室温に放置する。 (JIS C60068-2-2/MIL-STD-202 試験法 108)  Mate connectors and expose to 105 ±2 °C for 96 hours. Upon completion of the exposure period, the test specimens shall be conditioned at ambient room conditions for 1 to 2 hours , after which the specified measurements shall be performed. (JIS C60068-2-2/MIL-STD-202 Method 108)	外観 Appearance	製品機能を損なう異常なきこと No Damage on function
			接触抵抗 Contact Resistance	40 milliohms MAX.
4-3-6	耐寒性 Cold Resistance	コネクタを嵌合させ、-55±3°C の雰囲気中に96時間 放置後取り出し、1~2時間 室温に放置する。(JIS C60068-2-1)  Mate connectors and expose to -55 ±3 °C for 96 hours. Upon completion of the exposure period, the test specimens shall be conditioned at ambient room conditions for 1 to 2 hours, after which the specified measurements shall be performed. (JIS C60068-2-1)	外観 Appearance	製品機能を損なう異常なきこと No Damage on function
			接触抵抗 Contact Resistance	40 milliohms MAX.
4-3-7	耐湿性 Humidity	コネクタを嵌合させ、60±2°C、相対湿度90~95% の雰囲気中に 96時間 放置後取り出し、1~2時間 室温に放置する。 (JIS C60068-2-78/MIL-STD-202 試験法 103)  Mate connectors and expose to 60 ±2 °C, relative humidity 90 to 95 % for 96 hours. Upon completion of the exposure period, the test specimens shall be conditioned at ambient room conditions for 1 to 2 hours, after which the specified measurements shall be performed. (JIS C60068-2-78/MIL-STD-202 Method 103)	外観 Appearance	製品機能を損なう異常なきこと No Damage on function
			接触抵抗 Contact Resistance	40 milliohms MAX.
			絶縁抵抗 Insulation Resistance	100 Megohms MIN.
			耐電圧 Dielectric Strength	4-1-3項満足のこと Must meet 4-1-3

THIS DOCUMENT CONTAINS INFORMATION THAT IS PROPRIETARY TO MOLEX ELECTRONIC TECHNOLOGIES, LLC AND SHOULD NOT BE USED WITHOUT WRITTEN PERMISSION

REVISION DESCRIPTION	REVISED	<b>MINI-LOCK 2.5 W/B CONNECTOR</b>					
CHANGE NO.	728459						
REVISED BY	RWATANABE01	DATE	2022/11/15	DOC TYPE	DOC TYPE DESCRIPTION	DOC PART	SERIES
REV APPR BY	SAKIYAMA	DATE	2022/11/17	PS	ENGINEERING SPECIFICATION WORD	000	51163
INITIAL RELEASE				CUSTOMER	DOCUMENT NUMBER	REVISION	SHEET
INITIAL DRWN	RWATANABE01	DATE	2018/09/07	GENERAL	<b>511630000-PS</b>	<b>G</b>	7 OF 21
INITIAL APPR	TKANEKO	DATE	2018/09/10				

項目 Item		条件 Test Condition	規格 Requirement	
4-3-8	温度サイクル Temperature Cycling	<p>コネクタを嵌合させ、<math>-55\pm 3^{\circ}\text{C}</math> に 30分、<math>+105\pm 2^{\circ}\text{C}</math> に 30分。これを1サイクルとし、5サイクル 繰返す。 但し、温度移行時間は 5分以内 とする。 試験後1~2時間 室温に放置する。 (JIS C60068-2-14)</p> <p>Mate connectors and subject to the following conditions for 5 cycles. Upon completion of the exposure period, the test specimens shall be conditioned at ambient room conditions for 1 to 2 hours, after which the specified measurements shall be performed. 5 cycles of : a) <math>-55 \pm 3^{\circ}\text{C}</math>      30 minutes b) <math>+105 \pm 2^{\circ}\text{C}</math>      30 minutes Shift time : Within 5 minutes (JIS C60068-2-14)</p>	外 観 Appearance	製品機能を損なう 異常なきこと No Damage on function
			接 触 抵 抗 Contact Resistance	40 milliohms MAX.
4-3-9	塩 水 噴 霧 Salt Spray	<p>コネクタを嵌合させ、<math>35\pm 2^{\circ}\text{C}</math> にて <math>5\pm 1\%</math> 重量比の塩水を <math>48\pm 4</math>時間噴霧し、試験後 常温で水洗いした後、室温で乾燥させる。 (JIS C60068-2-11/MIL-STD-202 試験法101)</p> <p>Mate connectors and expose to the following salt mist conditions. Upon completion of the exposure period, salt deposits shall be removed by a gentle wash or dip in running water, after which the specified measurements shall be performed. NaCl solution Concentration : <math>5 \pm 1\%</math> Spray time : <math>48 \pm 4</math> hours Ambient temperature : <math>35 \pm 2^{\circ}\text{C}</math> (JIS 60068-2-11/MIL-STD-202 Method 101)</p>	外 観 Appearance	製品機能を損なう 異常なきこと No Damage on function
			接 触 抵 抗 Contact Resistance	40 milliohms MAX.

THIS DOCUMENT CONTAINS INFORMATION THAT IS PROPRIETARY TO MOLEX ELECTRONIC TECHNOLOGIES, LLC AND SHOULD NOT BE USED WITHOUT WRITTEN PERMISSION

REVISION DESCRIPTION	REVISED	<b>MINI-LOCK 2.5 W/B CONNECTOR</b>					
CHANGE NO.	728459						
REVISED BY	RWATANABE01	DATE	2022/11/15	DOC TYPE	DOC TYPE DESCRIPTION	DOC PART	SERIES
REV APPR BY	SAKIYAMA	DATE	2022/11/17	PS	ENGINEERING SPECIFICATION WORD	000	51163
INITIAL RELEASE				CUSTOMER	DOCUMENT NUMBER	REVISION	SHEET
INITIAL DRWN	RWATANABE01	DATE	2018/09/07	GENERAL	<b>511630000-PS</b>	<b>G</b>	8 OF 21
INITIAL APPR	TKANEKO	DATE	2018/09/10				



項 目 Item		条 件 Test Condition	規 格 Requirement	
4-3-10	耐亜硫酸ガス SO <sub>2</sub> Gas	コネクタを嵌合させ、40±2°Cにて50 ±5 ppmの亜硫酸ガス中に24時間放置する。  Mated connectors and expose to the conditions of 50 ±5 ppm SO <sub>2</sub> gas ambient temperature 40 ±2 °C for 24 hours.	外 観 Appearance	製品機能を損なう異常なきこと No Damage on function
			接 触 抵 抗 Contact Resistance	40 milliohms MAX.
4-3-11	耐アンモニア性 NH <sub>3</sub> Gas	コネクタを嵌合させ、濃度28%のアンモニア水を入れた容器中に40分間放置する。 (1Lに対して25mLの割合) Mated connectors and expose to the conditions of NH <sub>3</sub> gas evaporating from 28 % NH <sub>3</sub> solution for 40 minutes. (Rate is 25 ml per 1 L)	外 観 Appearance	製品機能を損なう異常なきこと No Damage on function
			接 触 抵 抗 Contact Resistance	40 milliohms MAX.

THIS DOCUMENT CONTAINS INFORMATION THAT IS PROPRIETARY TO MOLEX ELECTRONIC TECHNOLOGIES, LLC AND SHOULD NOT BE USED WITHOUT WRITTEN PERMISSION

REVISION DESCRIPTION	REVISED			<b>MINI-LOCK 2.5 W/B CONNECTOR</b>			
CHANGE NO.	728459						
REVISED BY	RWATANABE01	DATE	2022/11/15	DOC TYPE	DOC TYPE DESCRIPTION	DOC PART	SERIES
REV APPR BY	SAKIYAMA	DATE	2022/11/17	PS	ENGINEERING SPECIFICATION WORD	000	51163
INITIAL RELEASE				CUSTOMER	DOCUMENT NUMBER	REVISION	SHEET
INITIAL DRWN	RWATANABE01	DATE	2018/09/07	GENERAL	<b>511630000-PS</b>	<b>G</b>	9 OF 21
INITIAL APPR	TKANEKO	DATE	2018/09/10				

項 目 Item		条 件 Test Condition	規 格 Requirement	
4-3-12	はんだ付け性 Solderability	<u>スルーホールタイプ</u> Through Hole Type ターミナルまたはピンをフラックスに浸し、端子先端より1.2mm迄、 245±3°Cのはんだに3±0.5秒浸す。 Dip terminal or pin into flux, and immerse the area up to 1.2mm from the tip of terminal into solder molten at 245 ±3 °C for 3 ±0.5 sec.	濡れ性 Solder Wetting	ピンホールや隙間なく浸漬面積の95%以上 95% of immersed area must show no voids, pin holes.
		<u>SMTタイプ</u> SMT Type ターミナルまたはピンをフラックスに浸し、製品の基板実装面より0.2mm迄、 245±3°Cのはんだに3±0.5秒浸す。 Dip terminal or pin into flux, and immerse the area up to 0.2 mm from the product mounted surface on PCB into molten solder pot at 245±3 °C for 3±0.5 sec.		
4-3-13	はんだ耐熱性 Resistance to Soldering Heat	<u>スルーホールタイプの場合</u> Soldering bath method for Through Hole Type ターミナルまたはピンを本体取付け基準面より1.2mm迄、260±5°Cのはんだに5±0.5秒浸す。 Dip terminal or pin into immerse the area up to 1.2mm from the bottom of the housing into solder molten at 260 ±5 °C for 5 ±0.5 sec.	外 観 Appearance	端子ガタ、割れ等異常なきこと No Damage
		<u>SMTタイプ 赤外線リフロー時</u> Soldered by IR Reflow Machine for SMT Type 第7項の推奨温度プロファイル条件にてリフローを行う。 Using the reflow profile condition below paragraph 7, the product shall be reflowed.		
		<u>手はんだ時</u> (Manual Soldering iron method) 350±10°Cのはんだゴテにて最大5秒加熱する。但し、端ピンに異常な加圧のないこと。 Using a soldering iron (350±10°C for 5 seconds MAX.) heat up. However, do not apply excessive pressure to either the terminals.		

( ): 参考規格 Reference Standard

{ }: 参考単位 Reference Unit

THIS DOCUMENT CONTAINS INFORMATION THAT IS PROPRIETARY TO MOLEX ELECTRONIC TECHNOLOGIES, LLC AND SHOULD NOT BE USED WITHOUT WRITTEN PERMISSION

REVISION DESCRIPTION	REVISED	<b>MINI-LOCK 2.5 W/B CONNECTOR</b>					
CHANGE NO.	728459						
REVISED BY	RWATANABE01	DATE	2022/11/15	DOC TYPE	DOC TYPE DESCRIPTION	DOC PART	SERIES
REV APPR BY	SAKIYAMA	DATE	2022/11/17	PS	ENGINEERING SPECIFICATION WORD	000	51163
INITIAL RELEASE				CUSTOMER	DOCUMENT NUMBER	REVISION	SHEET
INITIAL DRWN	RWATANABE01	DATE	2018/09/07	GENERAL	<b>511630000-PS</b>	<b>G</b>	10 OF 21
INITIAL APPR	TKANEKO	DATE	2018/09/10				

## 【5. 外観形状、寸法及び材質 PRODUCT SHAPE, DIMENSIONS AND MATERIALS】

## 5-1. 製品寸法及び材質 Dimensions and materials of product.

図面参照 Refer to the drawing.

## 【6. 挿入力及び抜去力 INSERTION / WITHDRAWAL FORCE】

極数 No. of CKT	単位 UNIT	挿入力 (最大値) Insertion (MAX.)			抜去力 (最小値) Withdrawal (MIN.)		
		初回 1st	6回目 6th	30回目 30th	初回 1st	6回目 6th	30回目 30th
2	N {kgf}	16.6 { 1.70 }	16.6 { 1.70 }	16.6 { 1.70 }	2.0 { 0.20 }	2.0 { 0.20 }	2.0 { 0.20 }
3	N {kgf}	22.0 { 2.25 }	22.0 { 2.25 }	22.0 { 2.25 }	3.0 { 0.30 }	3.0 { 0.30 }	3.0 { 0.30 }
4	N {kgf}	29.4 { 3.00 }	29.4 { 3.00 }	29.4 { 3.00 }	4.0 { 0.40 }	4.0 { 0.40 }	4.0 { 0.40 }
5	N {kgf}	36.7 { 3.75 }	36.7 { 3.75 }	36.7 { 3.75 }	4.9 { 0.50 }	4.9 { 0.50 }	4.9 { 0.50 }
6	N {kgf}	44.1 { 4.50 }	44.1 { 4.50 }	44.1 { 4.50 }	5.9 { 0.60 }	5.9 { 0.60 }	5.9 { 0.60 }
7	N {kgf}	51.4 { 5.25 }	51.4 { 5.25 }	51.4 { 5.25 }	6.9 { 0.70 }	6.9 { 0.70 }	6.9 { 0.70 }
8	N {kgf}	58.8 { 6.00 }	58.8 { 6.00 }	58.8 { 6.00 }	7.9 { 0.80 }	7.9 { 0.80 }	7.9 { 0.80 }
9	N {kgf}	66.1 { 6.75 }	66.1 { 6.75 }	66.1 { 6.75 }	8.9 { 0.90 }	8.9 { 0.90 }	8.9 { 0.90 }
10	N {kgf}	73.5 { 7.50 }	73.5 { 7.50 }	73.5 { 7.50 }	9.8 { 1.00 }	9.8 { 1.00 }	9.8 { 1.00 }
11	N {kgf}	80.8 { 8.25 }	80.8 { 8.25 }	80.8 { 8.25 }	10.8 { 1.10 }	10.8 { 1.10 }	10.8 { 1.10 }
12	N {kgf}	88.2 { 9.00 }	88.2 { 9.00 }	88.2 { 9.00 }	11.8 { 1.20 }	11.8 { 1.20 }	11.8 { 1.20 }
13	N {kgf}	95.5 { 9.75 }	95.5 { 9.75 }	95.5 { 9.75 }	12.7 { 1.30 }	12.7 { 1.30 }	12.7 { 1.30 }
14	N {kgf}	102.9 { 10.50 }	102.9 { 10.50 }	102.9 { 10.50 }	13.7 { 1.40 }	13.7 { 1.40 }	13.7 { 1.40 }
15	N {kgf}	110.2 { 11.25 }	110.2 { 11.25 }	110.2 { 11.25 }	14.7 { 1.50 }	14.7 { 1.50 }	14.7 { 1.50 }

※ロックを解除して測定 Released lock, and measure.

{ } : 参考単位

Reference Unit

THIS DOCUMENT CONTAINS INFORMATION THAT IS PROPRIETARY TO MOLEX ELECTRONIC TECHNOLOGIES, LLC AND SHOULD NOT BE USED WITHOUT WRITTEN PERMISSION

REVISION DESCRIPTION	REVISED	<b>MINI-LOCK 2.5 W/B CONNECTOR</b>					
CHANGE NO.	728459						
REVISED BY	RWATANABE01	DATE	2022/11/15	DOC TYPE	DOC TYPE DESCRIPTION	DOC PART	SERIES
REV APPR BY	SAKIYAMA	DATE	2022/11/17	PS	ENGINEERING SPECIFICATION WORD	000	51163
INITIAL RELEASE				CUSTOMER	DOCUMENT NUMBER	REVISION	SHEET
INITIAL DRWN	RWATANABE01	DATE	2018/09/07	GENERAL	<b>511630000-PS</b>	<b>G</b>	11 OF 21
INITIAL APPR	TKANEKO	DATE	2018/09/10				

【7. SMTタイプ リフロー条件 REFLOW CONDITION FOR SMT TYPE】

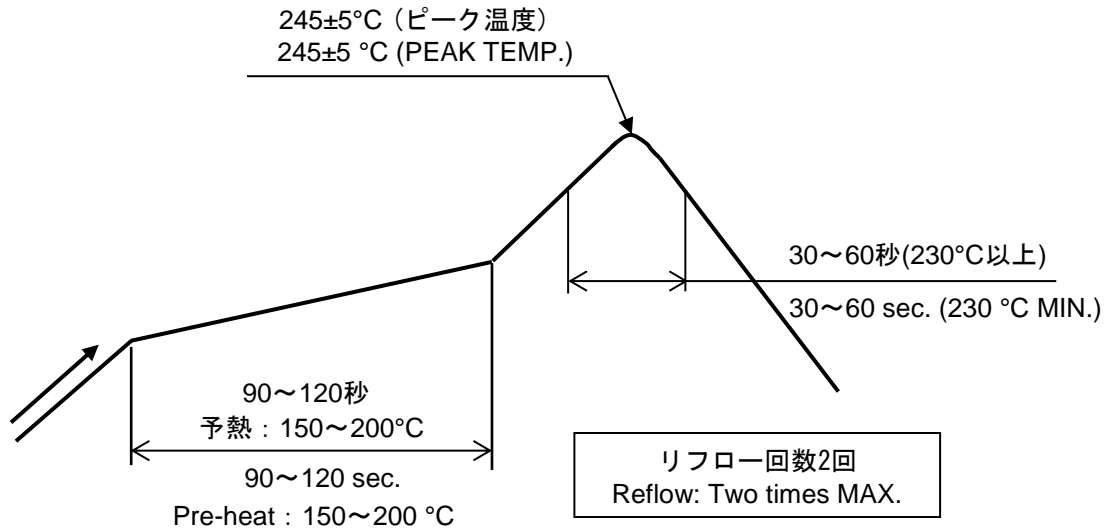

温度条件グラフ  
TEMPERATURE CONDITION GRAPH  
(はんだ接合部の基板表面にて測定)

(Temperature is measured at the soldering area on the surface of PCB)

注記 : 本リフロー条件に関しては、リフロー装置及び基板などにより条件が異なりますので  
 事前に実装評価(リフロー評価) の御確認を御願ひ致します。  
 端子テール部、ネイル部が変色する場合がございますが、はんだ付け性には問題ありません。  
 基板背面実装時には、コネクタの落下防止の為、固定する等の措置を御願ひ致します。  
 NOTE : Please check the mount condition (reflow soldering condition) by your own devices  
 beforehand, because each condition varies by the reflow machine, printed circuit boards (PCB),  
 and so on. Although tail of terminal and nail might be discolored, it does not affect solderability.  
 When mounting on the back of the board, please take measures such as fixing to prevent the  
 connector from falling.

THIS DOCUMENT CONTAINS INFORMATION THAT IS PROPRIETARY TO MOLEX ELECTRONIC TECHNOLOGIES, LLC AND SHOULD NOT BE USED WITHOUT WRITTEN PERMISSION

REVISION DESCRIPTION	REVISED	<b>MINI-LOCK 2.5 W/B CONNECTOR</b>					
CHANGE NO.	728459						
REVISED BY	RWATANABE01	DATE	2022/11/15	DOC TYPE	DOC TYPE DESCRIPTION	DOC PART	SERIES
REV APPR BY	SAKIYAMA	DATE	2022/11/17	PS	ENGINEERING SPECIFICATION WORD	000	51163
INITIAL RELEASE				CUSTOMER	DOCUMENT NUMBER	REVISION	SHEET
INITIAL DRWN	RWATANABE01	DATE	2018/09/07	GENERAL	<b>511630000-PS</b>	<b>G</b>	12 OF 21
INITIAL APPR	TKANEKO	DATE	2018/09/10				

**【8. 接触抵抗測定箇所 CONTACT RESISTANCE MEASURING POINT】**

[Through Hole Type]

接触抵抗 Contact Resistance  
mΩ=V/A

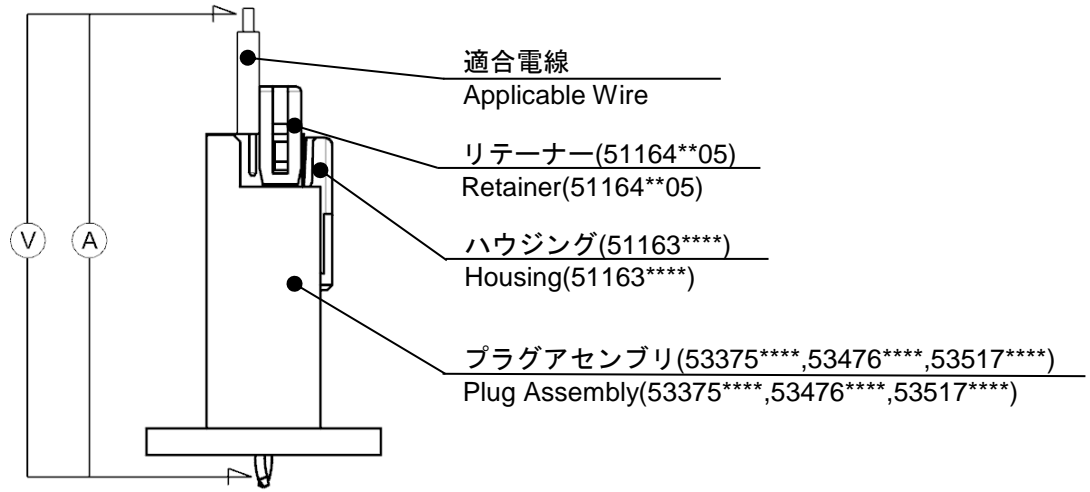

**VERTICAL TYPE**

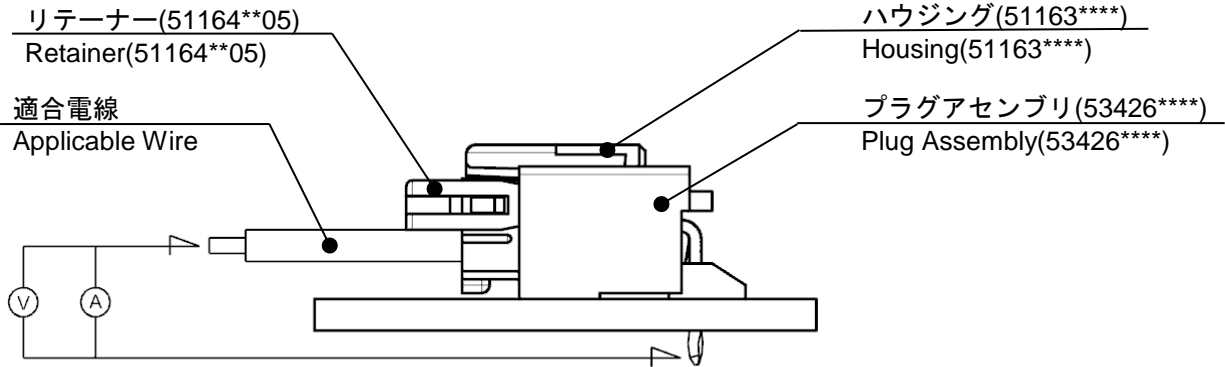

**RIGHT ANGLE TYPE**

THIS DOCUMENT CONTAINS INFORMATION THAT IS PROPRIETARY TO MOLEX ELECTRONIC TECHNOLOGIES, LLC AND SHOULD NOT BE USED WITHOUT WRITTEN PERMISSION

REVISION DESCRIPTION	REVISED	<b>MINI-LOCK 2.5 W/B CONNECTOR</b>							
CHANGE NO.	728459								
REVISED BY	RWATANABE01	DATE	2022/11/15	DOC TYPE	DOC TYPE DESCRIPTION	DOC PART	SERIES		
REV APPR BY	SAKIYAMA	DATE	2022/11/17	PS	ENGINEERING SPECIFICATION WORD	000	51163		
INITIAL RELEASE				CUSTOMER		DOCUMENT NUMBER		REVISION	SHEET
INITIAL DRWN	RWATANABE01	DATE	2018/09/07	GENERAL		<b>511630000-PS</b>		<b>G</b>	13 OF 21
INITIAL APPR	TKANEKO	DATE	2018/09/10						

[SMT Type]

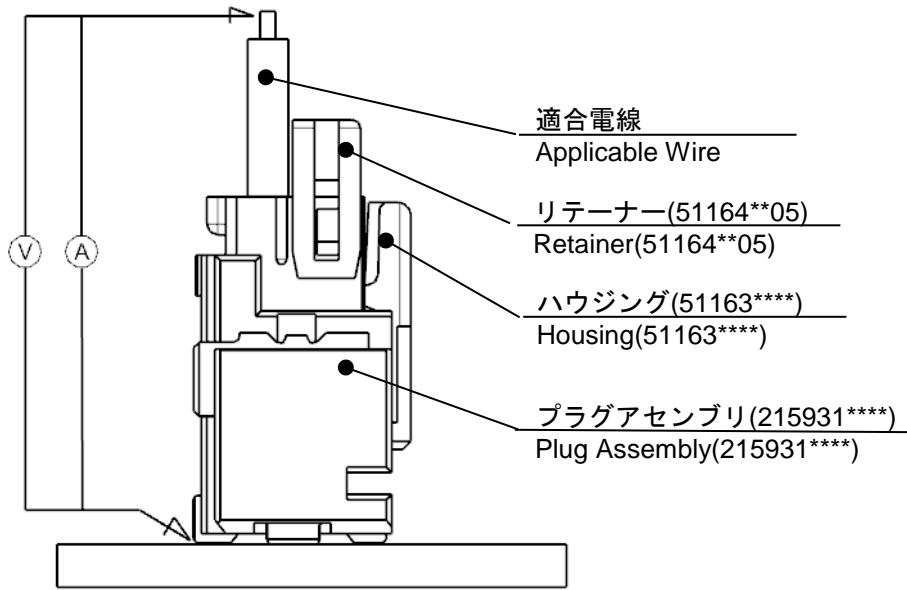

**VERTICAL TYPE**

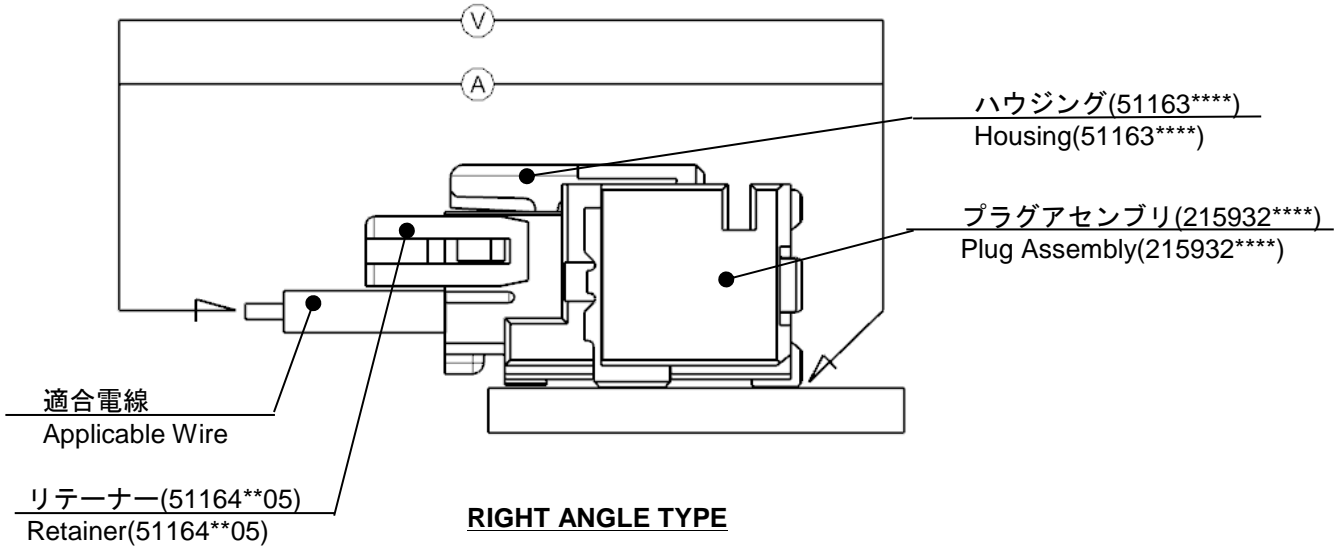

**RIGHT ANGLE TYPE**

THIS DOCUMENT CONTAINS INFORMATION THAT IS PROPRIETARY TO MOLEX ELECTRONIC TECHNOLOGIES, LLC AND SHOULD NOT BE USED WITHOUT WRITTEN PERMISSION

REVISION DESCRIPTION	REVISED	<b>MINI-LOCK 2.5 W/B CONNECTOR</b>					
CHANGE NO.	728459						
REVISED BY	RWATANABE01	DATE	2022/11/15	DOC TYPE	DOC TYPE DESCRIPTION	DOC PART	SERIES
REV APPR BY	SAKIYAMA	DATE	2022/11/17	PS	ENGINEERING SPECIFICATION WORD	000	51163
INITIAL RELEASE				CUSTOMER		DOCUMENT NUMBER	
INITIAL DRWN	RWATANABE01	DATE	2018/09/07	GENERAL	<b>511630000-PS</b>	<b>G</b>	14 OF 21
INITIAL APPR	TKANEKO	DATE	2018/09/10				

## 【9. 注記 NOTES.】

## &lt;1. 全般&gt;

- 1-1. コネクタの嵌合を取り外す際は、かならずロックを解除して行ってください。  
When connectors are unmated, positive locks shall be released.
- 1-2. 本製品のプラスチック部に黒点、気泡等が確認される場合や色合いが異なる場合（経年変化によるハウジングの変色を含む）が御座いますが、製品性能に影響は御座いません。  
There is no influence in the product performance though the black spot or bubble etc. might be confirmed to the plastic part of this product and the shade might be different (discoloration by secular distortion etc.).
- 1-3. 本製品は錫めっきを使用している為、外観に摺動痕がつく場合が御座いますが、製品性能に影響は御座いません。  
The wound of friction might adhere to externals because the tin plating is used for the tail. But there is no influence in the product performance.
- 1-4. 本製品のハウジング及びめっき表面に多少の傷が確認される場合がありますが、製品性能に問題御座いません。  
A few scratches may be confirmed to the surface of the housing and the plating of this product, however, There is no problem in the product performance.
- 1-5. 本製品のプラスチック部が紫外線により変色する場合がありますが、製品性能には問題御座いません。  
Discoloration of the plastic part of this product can result from exposure to ultraviolet light. There is no problem in the product performance.
- 1-6. 本製品を結露・水濡れが発生する環境でのご使用の場合は、適切な防滴処置をお願い致します。  
結露・水濡れにより、回路間で絶縁不良を起こす可能性が御座います。  
When this product is used at a place where exposure to water could be expected, please handle with appropriate care to avoid damage from water. There is a possibility of causing insulated malfunction between the circuits.
- 1-7. コネクタの性能を損なう恐れがある為、コネクタの洗浄は、行わないでください。  
Please do not conduct any washing process on the connectors because it may damage the product's function.
- 1-8. 本製品をご使用時に取り付けられた電線・プリント基板の共振や、機器の回転構造や可動部分の動作によりコネクタ嵌合部（接点部）が常に動いてしまう状態での御使用は避けてください。  
接触部の摺動磨耗等による 接触不良の原因となります。従って、機器内で電線・プリント基板を固定し、共振を抑える等の処置をお願い致します。  
Please do not use the connectors in a condition where the wire, PCB, or the contact area is experiencing a sympathetic vibration of wires and PCB, and constant movement of devices. This may cause a defect in the contact due to the contact area being worn down. Therefore, please fix wires and PCB on the chassis, and reduces sympathetic vibration.

THIS DOCUMENT CONTAINS INFORMATION THAT IS PROPRIETARY TO MOLEX ELECTRONIC TECHNOLOGIES, LLC AND SHOULD NOT BE USED WITHOUT WRITTEN PERMISSION

REVISION DESCRIPTION	REVISED			<b>MINI-LOCK 2.5 W/B CONNECTOR</b>					
CHANGE NO.	728459								
REVISED BY	RWATANABE01	DATE	2022/11/15	DOC TYPE	DOC TYPE DESCRIPTION		DOC PART	SERIES	
REV APPR BY	SAKIYAMA	DATE	2022/11/17	PS	ENGINEERING SPECIFICATION WORD		000	51163	
INITIAL RELEASE				CUSTOMER		DOCUMENT NUMBER		REVISION	SHEET
INITIAL DRWN	RWATANABE01	DATE	2018/09/07	GENERAL		<b>511630000-PS</b>		<b>G</b>	15 OF 21
INITIAL APPR	TKANEKO	DATE	2018/09/10						

- 1-9. コネクタ嵌合状態で基板の持ち運び等コネクタに負荷が掛かる作業は行わないようにしてください。コネクタ破損等の原因となる場合が御座います。  
Please do not do work that the load hangs in the connectors like the carrying of the substrate etc. with the connectors engages. There is a case where it causes the connectors damage etc.
- 1-10. 嵌合後、コネクタピッチ方向、スパン方向及び回転方向への負荷がかかるような動作またはセットはしないでください。コネクタ破壊やはんだクラックを引き起こします。  
After mated the connectors, please do not allow the PCBs to apply pressure on the connectors in either the pitch direction, the span direction or rotational direction. It may cause damage to the connectors and may crack the soldering.
- 1-11. 本製品及び加工工程品（仕掛品）や加工品（ハーネス等）の梱包及び輸送・保管時にはコネクタに負荷が加わらないようご注意ください。変形、破損などの原因となり、コネクタの性能不良の原因となります。  
Please try to prevent any external forces or shock from being applied to the connectors while the cable assembly is in process, when it is being packaged, or while it is in transportation. This may cause deformation and damage to the connectors and cause a defect in the product's performance.
- 1-12. 本製品をご使用時には、1PIN当りの定格以上の電流を複数の回路に分岐しての使用は避けてください。  
When using this product, please ensure that the specification for rated current per circuit is followed. Do not allow the sum of the current used on several circuits to exceed the maximum allowable current.
- 1-13. 活電状態の電気回路で、挿入、抜去ができることを前提に作られておりません。スパーク等による危険の発生、性能不良につながりますので、活電状態での挿入、抜去はしないでください。  
This product is not designed for the mating and unmating of the connectors to be performed under the condition of an active electrical circuit. It may cause a spark and product defect if the connectors are mated and unmated in this way.
- 1-14. コネクタに適用できる電線は、原則として錫めっきつき付軟銅撚り線です。その他の電線の使用については別途ご確認ください。  
The applicable wire for this connectors, in principle, is tin-plated copper stranded wire. Please consult us and evaluate it in advance when using other wires.
- 1-15. コネクタに外力が加わらないようにクリアランスをあけた筐体構造にしてください。  
Please keep enough clearance between connectors and chassis of your application in order not to apply pressure on the connectors.
- 1-16. 電線の結束はコネクタから45mm以上のところで、電線に加わる力が均一になるようにしてください。ハーネス品で電線一本（又は特定の数本）に力が加わらない様にしてください。  
Please tie the cable at least 45mm away from the edge of the connectors and try to ensure that the force is applied evenly on all of the wires.
- 1-17. 治具等を使用して圧着端子を抜いた場合には、ランスが変形し強度が低下し端子を再装着後の端子保持力が極端に低下します。そのため、圧着端子のリペアの際には新しいハウジングを必ず使用してください。  
When extracting a crimp terminal from the housing using a jig, it may deform the housing lance and therefore reduce the terminal retention force enormously after re-inserting of the terminal. Therefore, please ensure to use a new housing after repairing the crimp terminals.

THIS DOCUMENT CONTAINS INFORMATION THAT IS PROPRIETARY TO MOLEX ELECTRONIC TECHNOLOGIES, LLC AND SHOULD NOT BE USED WITHOUT WRITTEN PERMISSION

REVISION DESCRIPTION	REVISED	<b>MINI-LOCK 2.5 W/B CONNECTOR</b>					
CHANGE NO.	728459						
REVISED BY	RWATANABE01	DATE	2022/11/15	DOC TYPE	DOC TYPE DESCRIPTION	DOC PART	SERIES
REV APPR BY	SAKIYAMA	DATE	2022/11/17	PS	ENGINEERING SPECIFICATION WORD	000	51163
INITIAL RELEASE				CUSTOMER	DOCUMENT NUMBER	REVISION	SHEET
INITIAL DRWN	RWATANABE01	DATE	2018/09/07	GENERAL	<b>511630000-PS</b>	<b>G</b>	16 OF 21
INITIAL APPR	TKANEKO	DATE	2018/09/10				



- 1-18. ハーネス加工品及びコネクタ嵌合後の電線の引き回しの際、引張りによる力が加わりますと、接点部、結線部（圧着部）やロック部（端子ロック部）が損傷を受け、接触不良の原因となります。  
電線の引回し配線をされる場合、コネクタに無理な外力が加わらないように、電線に緩みを持たせ、余裕を持たせる処置をしてください。  
The cable assembly should not have a constant stress or pulling force applied on it when it is in the mated condition. This phenomenon may damage the contact area or wiring area (crimping).  
Therefore, when designing the wire positioning, please ensure that there is enough length of wire to avoid stress on the connectors.
- 1-19. 電線はまとめて軽くつかみ、リセプタクルハウジングのロックに指を添え、指の平を用いて、ロック解除用バーを押してロックを完全に解除してから、ゆっくり、軸方向にまっすぐに引き抜いてください。  
また、斜めにこじりながら抜くことは避けてください。コネクタを破損させる恐れが御座います。  
Please hold wires all together lightly. After releasing lock completely by attaching fingers to the Lock and pushing bar for releasing lock using flat part of finger, please withdraw receptacle housing slowly, axially and straightly. Please avoid withdrawing them with an angle and roughly. That might cause damage to connector.
- 1-20. ハウジングのロック部やランス部などの可動部、及び端子を故意に変形させないでください。  
製品性能が満足出来ない原因となります。  
Do not deform the movable part as lock part and lance part of Plug, HS'G and terminals on purpose. It would lead to product failure.
- 1-21. はんだ実装部の未はんだは、ターミナル脱落、ピン間ショート、ターミナル座屈、またコネクタ基板からの外れが懸念されます。従って全てのターミナルテール部及び、ネイル部にはんだ付けを行ってください。  
Please ensure to solder all the terminal tails and fitting nails on the PCB. When you leave any soldering area open, it may cause the short circuit between pins, terminal buckling or connector's coming off the PCB.
- 1-22. 実装機によってコネクタに負荷が加わると変形、破損する場合がありますので事前にご確認ください。  
If there is accidental contact with the connectors while it is going through the reflow machine, there may be deformation or damage caused to the connectors. Please check to prevent this.
- 1-23. 基板実装前後に端子及びネイルに触らないでください。  
Please do not directly touch the terminal and fitting nail area before and after mounting the connector on the PCB.
- 1-24. 基板実装後に基板を直接積み重ねない様に注意してください。  
Please do not stack the PCB directly after mounted the connectors on it.
- 1-25. 実装後において手はんだコテによるリペアを行なう際は、必ず仕様書掲載の条件以内で行なってください。  
条件を超えて実施した場合、端子の抜け、接点ギャップの変化、モールドの変形、溶融等が原因により破損の原因になります。  
Please conduct it under the condition of the specifications when repairing by hand soldering iron after mounting. In the case of practicing beyond the condition, the backlash, the change in the contact gap, the deformation of the mold and the melting, etc. may cause damage.
- 1-26. はんだコテによる手修正を行なう際、過度のはんだやフラックスを使用しないでください。はんだ上がりやフラックス上がりにより接触、機能不良に至る場合が御座います。  
When conducting manual repairs using a soldering iron, please do not use more solder and flux than needed. This may cause solder wicking and flux wicking issues, and it will eventually cause a contact defect and functional issues.

THIS DOCUMENT CONTAINS INFORMATION THAT IS PROPRIETARY TO MOLEX ELECTRONIC TECHNOLOGIES, LLC AND SHOULD NOT BE USED WITHOUT WRITTEN PERMISSION

REVISION DESCRIPTION	REVISED	<b>MINI-LOCK 2.5 W/B CONNECTOR</b>					
CHANGE NO.	728459						
REVISED BY	RWATANABE01	DATE	2022/11/15	DOC TYPE	DOC TYPE DESCRIPTION	DOC PART	SERIES
REV APPR BY	SAKIYAMA	DATE	2022/11/17	PS	ENGINEERING SPECIFICATION WORD	000	51163
INITIAL RELEASE				CUSTOMER	DOCUMENT NUMBER	REVISION	SHEET
INITIAL DRWN	RWATANABE01	DATE	2018/09/07	GENERAL	<b>511630000-PS</b>	<b>G</b>	17 OF 21
INITIAL APPR	TKANEKO	DATE	2018/09/10				

- 1-27. コネクタのみで基板を支えることは避け、コネクタ以外での基板固定対策を行ってください。  
Please do not use the connectors alone to provide mechanical support for the PCB.  
Please ensure that there is a fixed structure on the phone chassis or other component support for the PCB.
  
- 1-28. 弊社の推奨基板パターン寸法を変更して設計を行なう際は、致命的な不良の原因にもなりますので  
あらかじめご相談ください。  
In the case of changing our recommended board pattern size and designing, please consult in advance  
because it may cause a fatal defect.
  
- 1-29. 本品の一般性能確認はガラスエポキシ基板にて実施していますので、フレキシブル基板等の特殊な基板へ  
実装してご使用の際は、別途ご相談願います。  
It is necessary to consult separately when mount product on a special PCB or FPC.
  
- 1-30. 嵌合は極力嵌合軸に沿って平行に行ってください。その際、ハウジングとプラグの外壁同士を合わせる様に  
位置決めした後に押し込み、コネクタ同士が突き当たる（完全嵌合位置）まで真っ直ぐ押し込んでくださ  
い。斜めの嵌合になる場合は10°以下の角度でハウジングとプラグの外壁同士を軽く当て、位置決めした後  
に嵌合してください。尚、コネクタ同士を過度に傾けた状態で嵌合を行いますと、ハウジングが破壊する  
恐れがありますのでこのような嵌合はお避けください。  
Please do the mating as much as possible to along to mating axis. At this time, positioning each side of  
external faces of housing and plug and push to mating until both connectors strikes each other (complete  
mating position). In the case of diagonal mating, touch with external faces with housing and plug under the  
angle of 10° lightly, and push to mating in order to avoid the connector break.

THIS DOCUMENT CONTAINS INFORMATION THAT IS PROPRIETARY TO MOLEX ELECTRONIC TECHNOLOGIES, LLC AND SHOULD NOT BE USED WITHOUT WRITTEN PERMISSION

REVISION DESCRIPTION	REVISED			<b>MINI-LOCK 2.5 W/B CONNECTOR</b>			
CHANGE NO.	728459						
REVISED BY	RWATANABE01	DATE	2022/11/15	DOC TYPE	DOC TYPE DESCRIPTION	DOC PART	SERIES
REV APPR BY	SAKIYAMA	DATE	2022/11/17	PS	ENGINEERING SPECIFICATION WORD	000	51163
INITIAL RELEASE				CUSTOMER	DOCUMENT NUMBER	REVISION	SHEET
INITIAL DRWN	RWATANABE01	DATE	2018/09/07	GENERAL	<b>511630000-PS</b>	<b>G</b>	18 OF 21
INITIAL APPR	TKANEKO	DATE	2018/09/10				

1-31. ハウジング（製品番号51163\*\*\*\*）にリテーナー（製品番号51164\*\*05）を挿入する際、図1に示した方向からリテーナー先端が挿入済みの端子に突き当たるまで挿入してください。この際挿入初期に図2のようにリテーナーを下へ傾けると、電線によりガイドされて挿入し易くなります。又、挿入後軽く電線を引張って端子が抜け出さないか確認ください。

When inserting the retainer (51164\*\*05) into the housing (51163\*\*\*\*), please ensure that the retainer is inserted completely and touches the end of the housing. Please insert the terminal in the correct direction as showing in Fig.1. At the beginning of its insertion, the inclined retainer like Fig.2 makes the insertion easier because of guided cables. Also, please pull the wire lightly after inserting the terminal to ensure that the terminal is fully inserted and can not be pulled out.

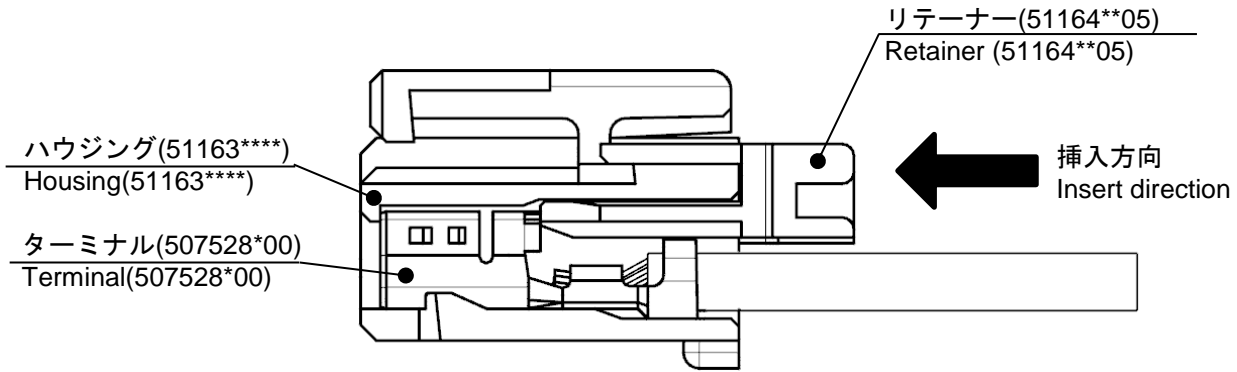

**図1**  
**Fig.1**

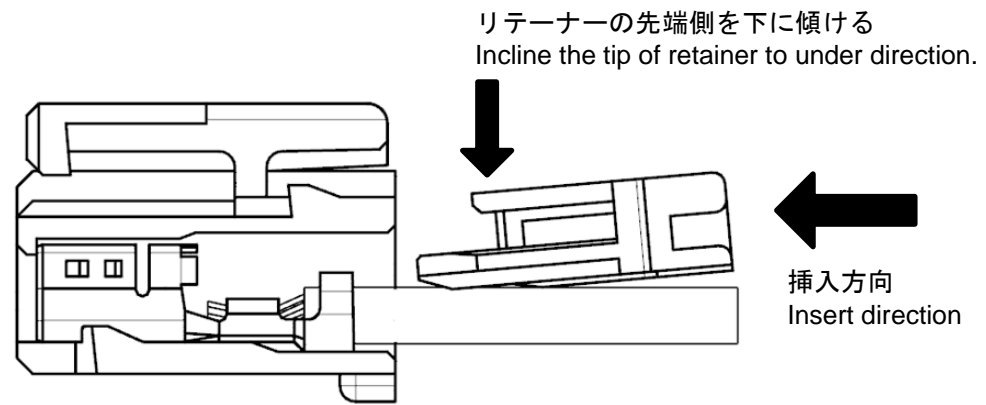

**図2**  
**Fig.2**

THIS DOCUMENT CONTAINS INFORMATION THAT IS PROPRIETARY TO MOLEX ELECTRONIC TECHNOLOGIES, LLC AND SHOULD NOT BE USED WITHOUT WRITTEN PERMISSION

REVISION DESCRIPTION	REVISED	<b>MINI-LOCK 2.5 W/B CONNECTOR</b>					
CHANGE NO.	728459						
REVISED BY	RWATANABE01	DATE	2022/11/15	DOC TYPE	DOC TYPE DESCRIPTION	DOC PART	SERIES
REV APPR BY	SAKIYAMA	DATE	2022/11/17	PS	ENGINEERING SPECIFICATION WORD	000	51163
INITIAL RELEASE				CUSTOMER	DOCUMENT NUMBER	REVISION	SHEET
INITIAL DRWN	RWATANABE01	DATE	2018/09/07	GENERAL	<b>511630000-PS</b>	<b>G</b>	19 OF 21
INITIAL APPR	TKANEKO	DATE	2018/09/10				

<2. W/B Through Hole Type>

2-1. コネクタを基板に対して垂直に真っ直ぐ挿入してください。斜めにしたりコジリを加えたりしないでください。

※コネクタを保持する際にはコンタクトに触れることの無い様に御注意ください。

※コネクタを基板に対して垂直に保持した状態で真っ直ぐに基板穴へソルダーテールを挿入してください。

※基板穴とソルダーテールがずれる方向や斜めに傾く様な力を加えないでください。

※無理に斜め挿入を行った場合、ピンの変形、抜けが生じ、コネクタが破損する恐れがあります

Load the connector into the PCB straight down. Do not tilt or squeeze the connector in wrong directions.

※When touching the connector, be sure not to touch the contacts.

※Load the solder tails straightly into the PCB.

※Do not apply force in such directions that would damage the solder tails.

※In case you push the solder tails in such directions, the pin deformations and pin fallout would occur and damage the connector.

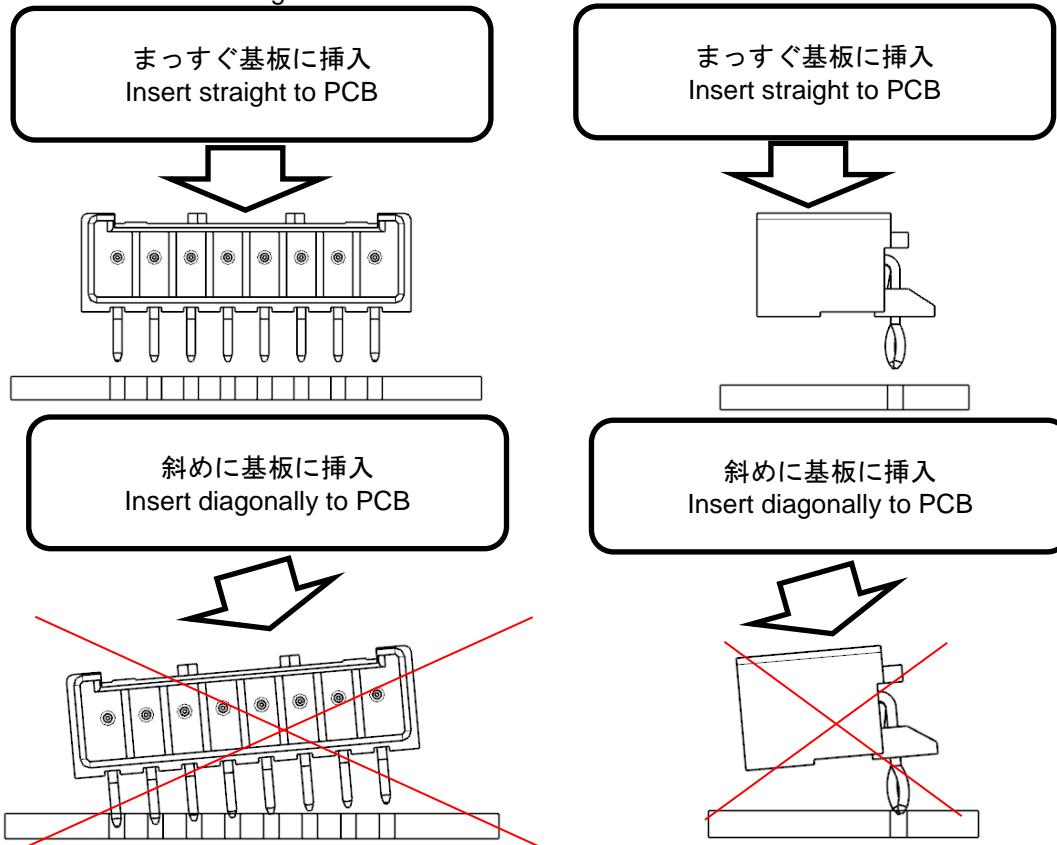

2-2. プラグアセンブリ（製品番号53517\*\*\*\*）のポッティング処理を行う場合、ご使用のポッティング材料や使用環境にて事前に評価を行いご確認ください。

When casting treatment of plug assembly(53517\*\*\*\*), please check the state by your own material and condition beforehand.

2-3. プラグアセンブリ（製品番号53517\*\*\*\*）はポッティング高さを2mmから6mmと想定していますが、ご使用のポッティング材料にて嵌合部への吸い上がり、流れ込みがなく挿抜性に影響がないことをご確認ください。

Plug assembly(53517\*\*\*\*) is supposed the potting height is approximately 2 mm – 6 mm, however it could change the proper height depend on the potting material. Please check the wicking or inflow to mating area, and check no effect to insertion the connector.

THIS DOCUMENT CONTAINS INFORMATION THAT IS PROPRIETARY TO MOLEX ELECTRONIC TECHNOLOGIES, LLC AND SHOULD NOT BE USED WITHOUT WRITTEN PERMISSION

REVISION DESCRIPTION	REVISED	<b>MINI-LOCK 2.5 W/B CONNECTOR</b>					
CHANGE NO.	728459						
REVISED BY	RWATANABE01	DATE	2022/11/15	DOC TYPE	DOC TYPE DESCRIPTION	DOC PART	SERIES
REV APPR BY	SAKIYAMA	DATE	2022/11/17	PS	ENGINEERING SPECIFICATION WORD	000	51163
INITIAL RELEASE				CUSTOMER	DOCUMENT NUMBER	REVISION	SHEET
INITIAL DRWN	RWATANABE01	DATE	2018/09/07	GENERAL	<b>511630000-PS</b>	<b>G</b>	20 OF 21
INITIAL APPR	TKANEKO	DATE	2018/09/10				

## &lt;3. W/B SMT Type&gt;

- 3-1. リフロー条件によっては端子めっき部にヨリ等が発生する場合がありますが、製品性能には影響ありません。  
There is no influence in the product performance though the twist appearance in the terminal plating area might be generated by some reflow conditions.
- 3-2. リフロー条件によっては樹脂部に変色が発生する場合がありますが、製品性能には影響ありません。  
There is no influence in the product performance though the discoloration in the resin area might be seen by some reflow conditions.
- 3-3. リフロー後、はんだ付け部に変色が見られることがあります。製品性能に影響はありません。  
There is no influence in the product performance though the discoloration in the soldering area might be seen after reflow.
- 3-4. 本製品は赤外線リフローでの実装を想定しています。N<sub>2</sub>リフローで実装した場合、リフロー後、はんだ上がりを生じる恐れがあります。N<sub>2</sub>リフローでの実装をお考えの場合、別途評価が必要になります。  
This product is designed for using IR (Infrared) reflow machine. When using Nitrogen reflow machine, it might generate the solder wicking issue. Please evaluate the mounting condition (reflow soldering condition) beforehand when using Nitrogen reflow machine.  
The mounting conditions may change due to the soldering temperature, soldering paste, IR reflow machine, Nitrogen reflow machine, and the type of PCB. The different mounting conditions may influence in the product performance.
- 3-5. 弊社評価では厚さ0.15mm、開口率100%のメタルマスクを使用しています。  
The stencil (thickness 0.15 mm / aperture ratio 100 %) is used in this product specification evaluation.
- 3-6. 実装性能（平坦度）は、実装基板の反りの影響を含まないものと致します。基板の反りはコネクタ両端部を基準とし、コネクタ中央部にて 0.02mm以下としてください。  
The connector mounting specification for coplanarity does not include the influence of the PCB warpage. The warpage of the PCB should be a less than 0.02 mm at the center of connector when setting both edges of connector as the datum.
- 3-7. 本製品の平坦度については、実装前での保証のみであり、実装中および実装後での平坦度については、保証の限りではありません。  
The coplanarity of this product is assured only before mounting/reflowing condition. There is no product guarantee in terms of coplanarity during and after mounting/reflowing.

THIS DOCUMENT CONTAINS INFORMATION THAT IS PROPRIETARY TO MOLEX ELECTRONIC TECHNOLOGIES, LLC AND SHOULD NOT BE USED WITHOUT WRITTEN PERMISSION

REVISION DESCRIPTION	REVISED			<b>MINI-LOCK 2.5 W/B CONNECTOR</b>			
CHANGE NO.	728459						
REVISED BY	RWATANABE01	DATE	2022/11/15	DOC TYPE	DOC TYPE DESCRIPTION	DOC PART	SERIES
REV APPR BY	SAKIYAMA	DATE	2022/11/17	PS	ENGINEERING SPECIFICATION WORD	000	51163
INITIAL RELEASE				CUSTOMER	DOCUMENT NUMBER	REVISION	SHEET
INITIAL DRWN	RWATANABE01	DATE	2018/09/07	GENERAL	<b>511630000-PS</b>	<b>G</b>	21 OF 21
INITIAL APPR	TKANEKO	DATE	2018/09/10				