

22DCP Athlonix™

Ø 22 mm • Precious metal commutation • 6.5 mNm

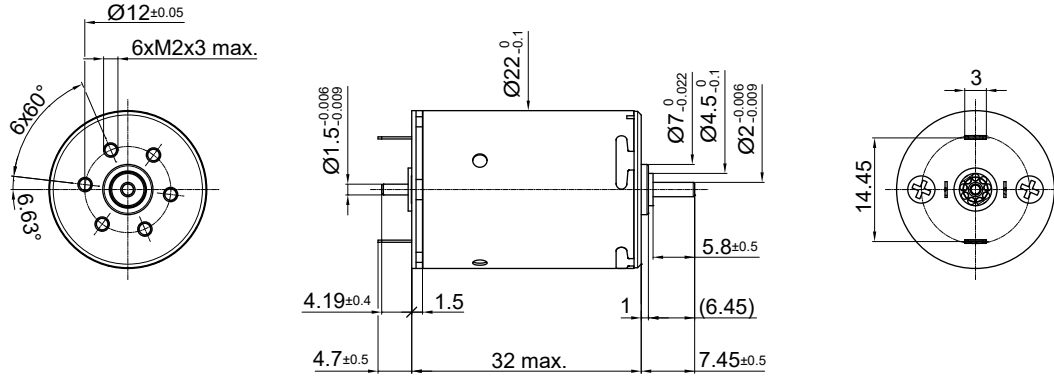

Dimensions in mm.

Electrical Data	Symbol	22DCP 32P2 **** .2						Unit
		221P	216P	213P	211P	210P	209P	
1 Nominal Voltage	V	3	6	9	12	15	18	Volt
2 No-Load Speed	n ₀	8321	9739	10022	9741	9741	9348	rpm
3 No-Load Current	I ₀	58.9	34.4	23.6	17.2	13.8	11.0	mA
4 Terminal Resistance	R	0.7	2.0	4.1	7.8	12.1	18.6	Ω
5 Output Power	P _{2max.}	2.9	4.1	4.4	4.2	4.2	4.0	W
6 Stall Torque	mNm	13.65 (1.94)	17.47 (2.48)	18.34 (2.6)	17.81 (2.53)	17.83 (2.53)	17.37 (2.46)	mNm (oz-in)
7 Efficiency	h _{max.}	77	80	80	80	80	80	%
8 Max Continuous Speed	n _{e max.}	10000	10000	10000	10000	10000	10000	rpm
9 Max Continuous Torque	M _{e max.}	6.09 (0.87)	6.38 (0.91)	6.45 (0.92)	6.44 (0.92)	6.45 (0.92)	6.5 (0.93)	mNm (oz-in)
10 Max Continuous Current	I _{e max.}	1.85	1.13	0.78	0.57	0.46	0.37	A
11 Back-EMF Constant	k _E	0.36	0.61	0.89	1.22	1.52	1.90	mV/rpm
12 Torque Constant	k _M	3.39	5.82	8.48	11.63	14.54	18.18	mNm/A
13 Motor Regulation	R/k ²	63.83	58.37	57.22	57.28	57.22	56.34	10 ³ /Nms
14 Friction Torque	T _F	0.2 (0.03)	0.2 (0.03)	0.2 (0.03)	0.2 (0.03)	0.2 (0.03)	0.2 (0.03)	mNm (oz-in)
15 Mechanical Time Constant	τ _m	30.63	27.87	27.12	26.81	26.68	26.60	ms
16 Rotor Inertia	J	4.80	4.78	4.74	4.68	4.66	4.72	g-cm ²

General Data				
17 Thermal Resistance (rotor/body)	R _{th1} /R _{th2}	6/22		°C/W
18 Thermal Time Constant (rotor/stator)	t _{w1} /t _{w2}	9/550		S
19 Operating Temperature Range:	motor	-30°C to 85°C (-22°F to 185°F)		°C (°F)
	rotor			100°C (212°F)
20 Shaft Load Max.: (5 mm. from bearing)	-radial -axial	With sleeve bearings		
		1.5 (5.39)		N (oz)
		100 (359.6)		N (oz)
21 Shaft Play:	-radial	0.03 (0.0012)		mm (inch)
	-axial	0.15 (0.0059)		mm (inch)
22 Weight	g	58 (2.05)		g (oz)
23 Commutation Segment	-	9		segment

*Also available with ball bearing

Execution Table

Gearbox	Single Shaft	MR2	E9
R22	4	5	6
K24	7	8	9
K27	1	2	3
R22HT	11	Upon Request	Upon Request

Note:

P1: standard commutation

P2: special commutation for double shaft version

► Motor shaft rotates CW when seen from motor front face when +ve and -ve supply is given to respective terminals.

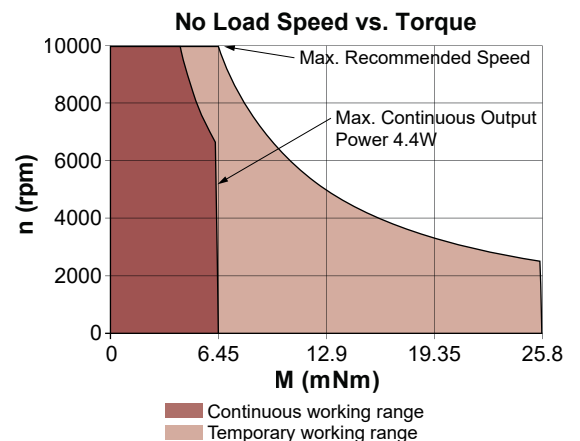

22DCP Athlonix™

Ø 22 mm • Precious metal commutation • 6.5 mNm

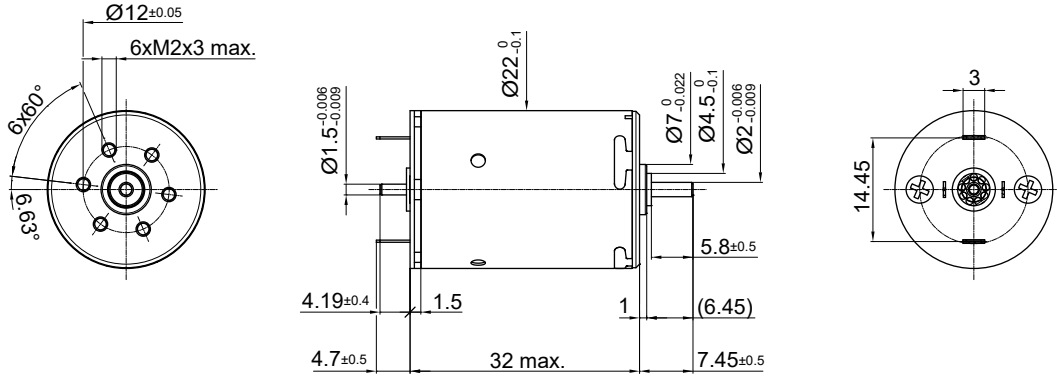

Dimensions in mm.

Electrical Data	Symbol	22DCP 32P2 2					Unit
		212E	211E	210E	209E	208E	
1 Nominal Voltage	V	21	24	30	36	48	Volt
2 No-Load Speed	n_0	10,357	10,465	10,806	10,281	11,049	rpm
3 No-Load Current	I_0	10.5	9.2	7.6	6.1	4.9	mA
4 Terminal Resistance	R	23.4	30.4	46.1	71.7	112.6	Ω
5 Output Power	P_{2max}	4.2	4.3	4.4	4.1	4.5	W
6 Stall Torque	mNm	16.95 (2.41)	16.89 (2.4)	16.85 (2.39)	16.39 (2.33)	17.28 (2.45)	mNm (oz-in)
7 Efficiency	h_{max}	80	80	80	79	80	%
8 Max Continuous Speed	$n_{e max}$	10,000	10,000	10,000	10,000	10,000	rpm
9 Max Continuous Torque	$M_{e max}$	6.08 (0.86)	6.04 (0.86)	5.93 (0.84)	6 (0.85)	5.94 (0.85)	mNm (oz-in)
10 Max Continuous Current	$I_{e max}$	0.33	0.29	0.23	0.19	0.15	A
11 Back-EMF Constant	k_E	2.00	2.27	2.74	3.46	4.29	mV/rpm
12 Torque Constant	k_M	19.14	21.64	26.20	33.03	41.01	mNm/A
13 Motor Regulation	R/k^2	64.0	64.9	67.2	65.70	66.95	$10^3/Nms$
14 Friction Torque	T_F	0.2 (0.03)	0.2 (0.03)	0.2 (0.03)	0.2 (0.03)	0.2 (0.03)	mNm (oz-in)
15 Mechanical Time Constant	τ_m	30.1	30.0	30.0	30.0	30.0	ms
16 Rotor Inertia	J	4.70	4.63	4.47	4.56	4.48	g-cm ²

General Data				
17 Thermal Resistance (rotor/body)	R_{th1}/R_{th2}	6/22		$^{\circ}\text{C}/\text{W}$
18 Thermal Time Constant (rotor/stator)	t_{w1}/t_{w2}	9/550		S
19 Operating Temperature Range:	motor	-30°C to 85°C (-22°F to 185°F)		$^{\circ}\text{C}$ ($^{\circ}\text{F}$)
	rotor	100°C (212°F)		$^{\circ}\text{C}$ ($^{\circ}\text{F}$)
20 Shaft Load Max.: (5 mm. from bearing)	-radial -axial	With sleeve bearings		
		1.5 (5.39)		N (oz)
		100 (359.6)		N (oz)
21 Shaft Play:	-radial	0.03 (0.0012)		mm (inch)
	-axial	0.15 (0.0059)		mm (inch)
22 Weight	g	58 (2.05)		g (oz)
23 Commutation Segment	-	9		segment

*Also available with ball bearing

Execution Table

Gearbox	Single Shaft	MR2	E9
R22	4	5	6
K24	7	8	9
K27	1	2	3
R22HT	11	Upon Request	Upon Request

Note:
P1: standard commutation
P2: special commutation for double shaft version

► Motor shaft rotates CW when seen from motor front face when +ve and -ve supply is given to respective terminals.

