

SS Stainless Steel

3 Type

- L** Left-hand assembly angle bracket
- R** Right-hand assembly angle bracket

Metric table

Dimensions in: millimeters - inches

l₁	d	h₁	h₂	h₃	l₂	l₃	l₄	l₅	l₆	l₇	l₈	l₉	m₁	m₂	r	s	x	y
40	5.3	7.5	28	2.5	26	36	79	96	33.8	65.9	27.9	77.4	25	5	70	4	23	30.5
1.57	0.21	0.30	1.10	0.10	1.02	1.42	3.11	3.78	1.33	2.59	1.10	3.05	0.98	0.20	2.76	0.16	0.91	1.20
50	6.5	10	35	2.5	35	46	105	135	79.3	82	2.8	113.3	30	6	105	5	20	37
1.97	0.26	0.39	1.38	0.10	1.38	1.81	4.13	5.31	3.12	3.23	0.11	4.46	1.18	0.24	4.13	0.20	0.79	1.46
60	8.5	12.5	40	2.5	40	61	130	169	87.5	107.5	17.4	147.1	36	8	125	5	34	50
2.36	0.33	0.49	1.57	0.10	1.57	2.40	5.12	6.65	3.44	4.23	0.69	5.79	1.42	0.31	4.92	0.20	1.34	1.97

Specification

- Body
Stainless steel AISI 304
Matte, tumbled finish
- Friction bearing
Bronze, self-lubricated
- *Stainless Steel Characteristics* → page 2143
- **RoHS compliant**

1 **4**

NI **MT**

On request

- Other materials
- Other finishes
- Other assembly angle brackets
- Other opening angles
- Other max. wall thicknesses
- Other lifting motion

Information

GN 7233 multiple-joint hinges are installed on the inside of flaps, hatches and doors to save space and ensure protection against vandalism. The hinges have a maximum opening angle of 120°, allowing for easy accessibility and making them suitable for use with medium-thick door leaves.

Use of this hinge type leaves housing exteriors free of attachments that do not match the design or that should be avoided entirely in the interests of fast and easy cleaning.

Multiple-joint hinges are typically used in pairs, meaning that one L type and one R type is used per opening. For higher loads, e.g. from large hatches, these can be supplemented with additional hinges of any type.

see also...

- *Spacer Plates GN 2370* → page 1380
- *Spacer Plates with Tapped Holes GN 2372* → page 1381
- *Mounting Plates with Threaded Studs GN 2376* → page 1382

How to order	1	Material
	2	Length l ₁
	3	Type
	4	Finish

GN 7233-NI-60-L-MT

Installation position – pivot characteristics

Multiple-joint hinges can be installed on the housing with the slotted holes of the assembly angle brackets that are either perpendicular or parallel to the hinge axis. This results in the two pivot characteristics depicted.

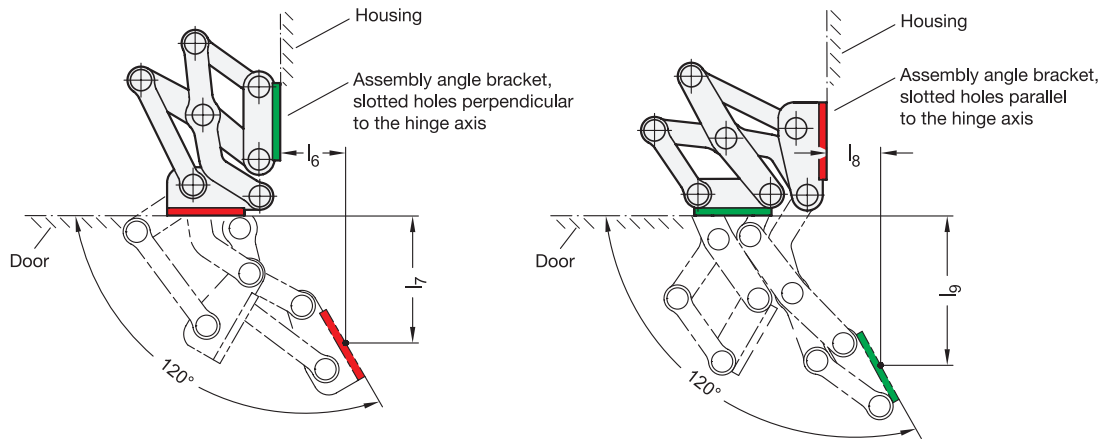

Application examples

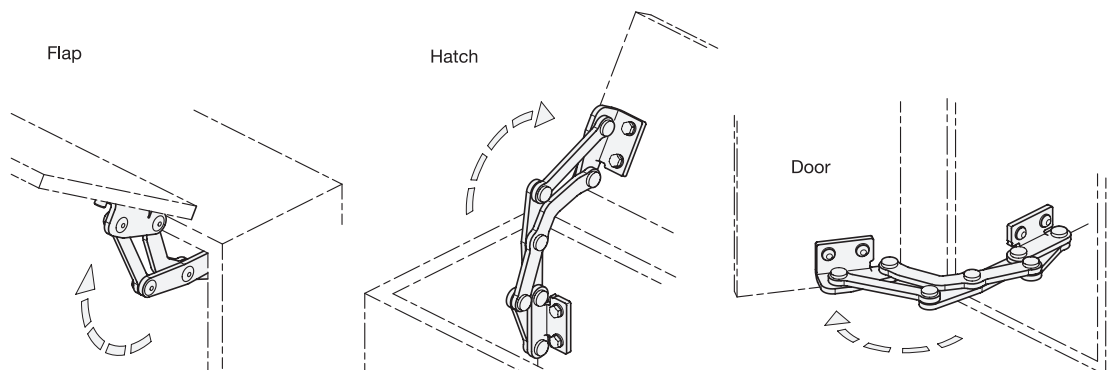

Adjustment and mounting options

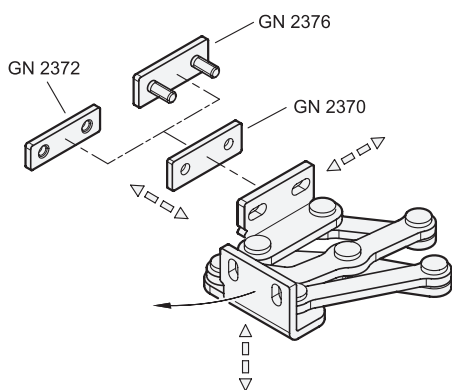

Multiple-joint hinges can be adjusted in three planes during installation. For example, this allows compensation for tolerances or establishing of required compressive forces for seals.

Two planes can be adjusted via parallel or perpendicular slotted holes in the assembly angle brackets. In the third plane, position corrections can be made using GN 2370 spacer plates.

GN 2372 spacer plates with tapped holes as well as GN 2376 mounting plates with threaded studs are also available for mounting the hinges. The latter can be welded on or inserted through the wall from the outside and fastened in place.

All accessory items are designed for use with both assembly angle brackets.

3.1
3.2
3.3
3.4
3.5
3.6
3.7
3.8
3.9
3.10



Design variants

Flaps, hatches and doors can be inset, surface-mounted or mitered. The maximum wall thicknesses and bend sizes for planned sheet metal constructions arise from the respective installation type.

1. Assembly angle brackets mounted to the housing with slotted holes perpendicular to the hinge axis:

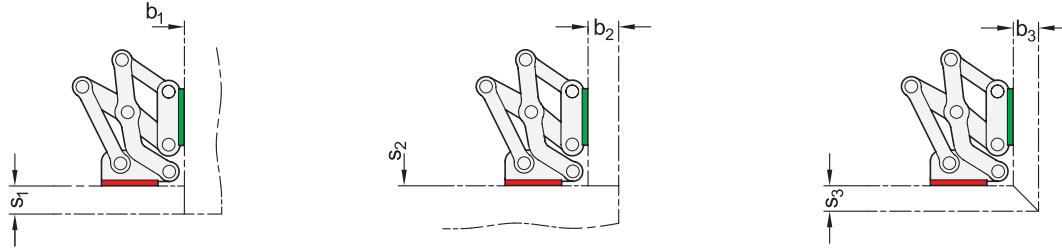

l_1	s_1 max.	b_1	s_2 max.	b_2 max.	s_3 max.	b_3 max.
40 1.57	20 0.79	1 ... ∞	1 ... ∞	22 0.87	18 0.71	18 0.71
50 1.97	25 0.98	1 ... ∞	1 ... ∞	38 1.50	30 1.18	30 1.18
60 2.36	32 1.26	1 ... ∞	1 ... ∞	50 1.97	40 1.57	40 1.57

2. Assembly angle brackets mounted to the housing with slotted holes parallel to the hinge axis:

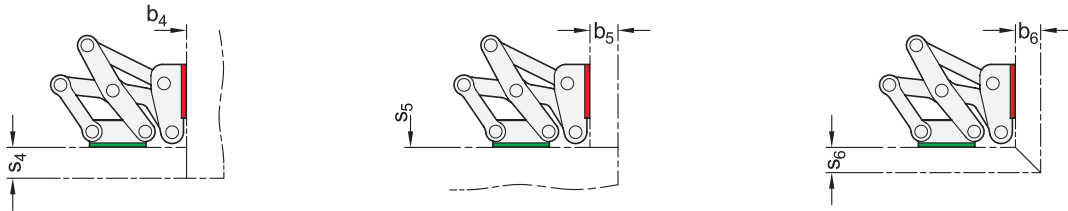

l_1	s_4 max.	b_4 max.	s_5	b_5 max.	s_6 max.	b_6 max.
40 1.57	22 0.87	1 ... ∞	1 ... ∞	20 0.79	18 0.71	18 0.71
50 1.97	38 1.50	1 ... ∞	1 ... ∞	25 0.98	30 1.18	30 1.18
60 2.36	50 1.97	1 ... ∞	1 ... ∞	32 1.26	40 1.57	40 1.57

The design variants shown represent standard installation conditions. If the installation position of the hinge is changed or one of the two wall thickness dimensions s or b are lower, the maximum achievable dimensions change independently of each other. This makes it possible in some cases to work with larger wall thickness dimensions than those specified with the same hinge size. A simple design check via CAD or a test setup is therefore recommended.

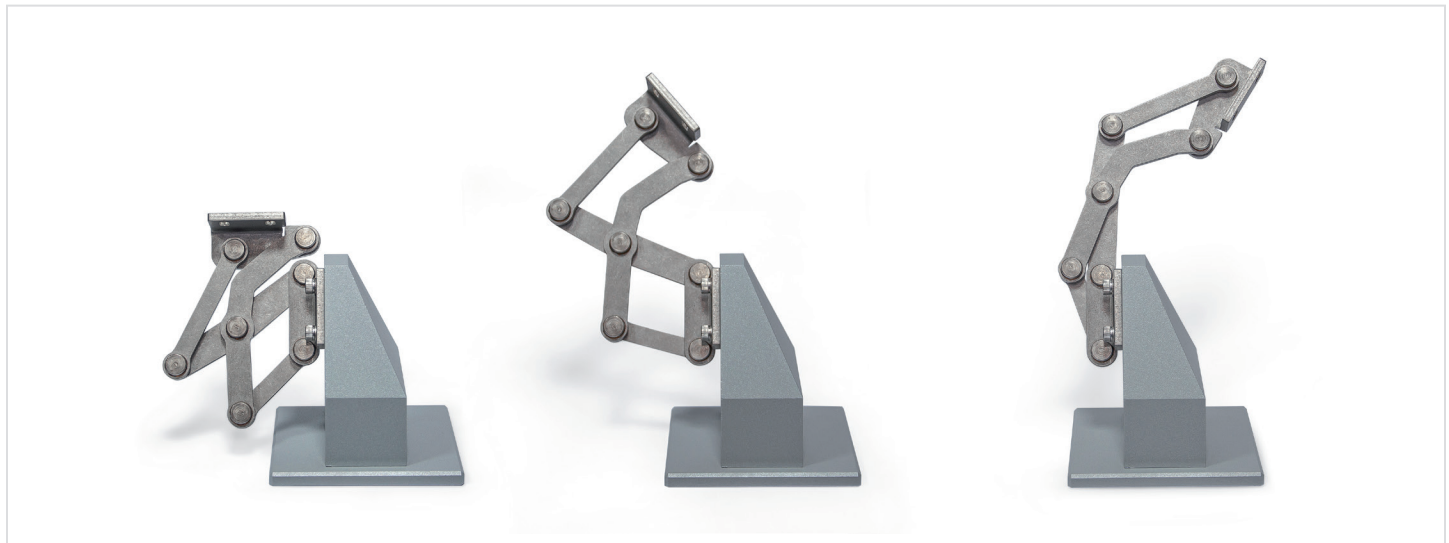

Construction example

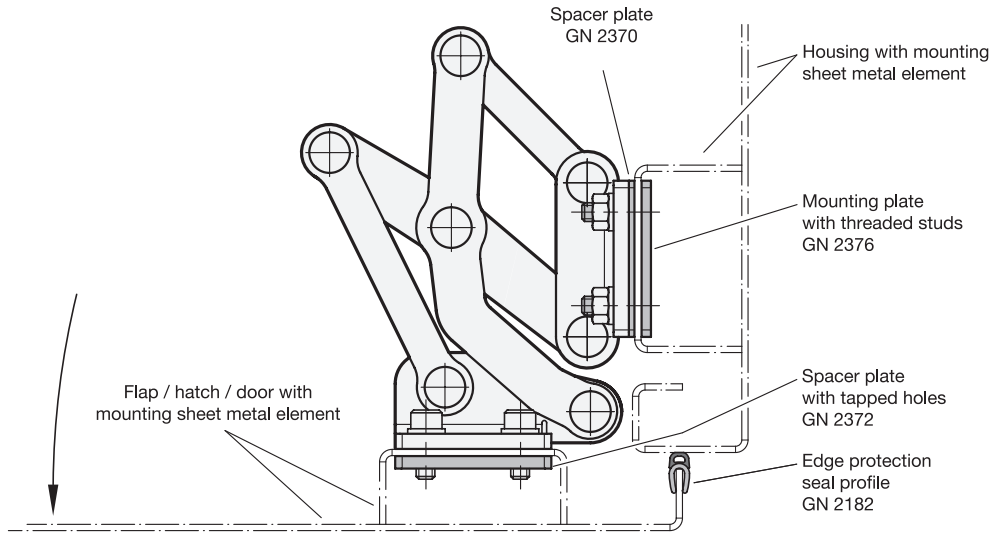

Load capacity

The maximum load of the multiple-joint hinges specified below applies to the standard use cases and serves for orientation in the case of deviating applications. The resulting forces lead to slight elastic deformation, which can be compensated for by means of the adjustment options, if necessary.

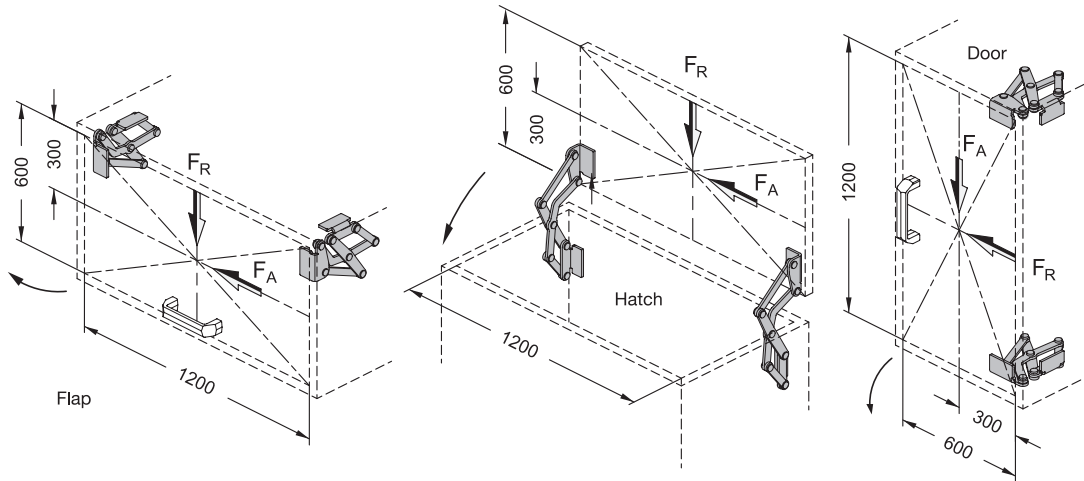

Max. load capacity per hinge pair		
I_1	F_A (axial)	F_R (radial)
40 1.57	175 N 39.34 lbf	650 N 146.13 lbf
50 1.97	175 N 39.34 lbf	750 N 168.61 lbf
60 2.36	150 N 33.72 lbf	550 N 123.65 lbf

3.1
3.2
3.3
3.4
3.5
3.6
3.7
3.8
3.9
3.10

