

**Crimp Tool Kit
For Imperium Plus**

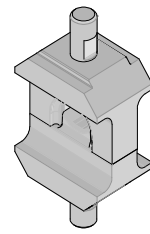

**Application Tooling
Specification Sheet**



Order No. 19290-0200

SCOPE

Tooling: Shank style Crimp Tool Kits are used with the Hydraulic Head Crimper with the Air/Hydraulic Pump (19286-1000). Refer to the appropriate tool instruction manual for installation and operation information.

Products: Imperium Plus Terminals to 1/0 AWG post-tinned copper wire. Refer to the Product part number charts on this sheet for terminals.

Testing

The tensile test or pull test is a means of evaluating the mechanical properties of the crimped connections. The following chart shows the specifications for the wire size. The tensile strength is shown in Newtons and (pounds) and indicates the minimum acceptable force to break or separate the terminal from the conductor.

Wire Size (AWG)	Minimum Pull (UL 486)
1/0	1112N (250 lbs.)

Crimp measurement

After crimping, the terminal crimp profiles should measure the following:

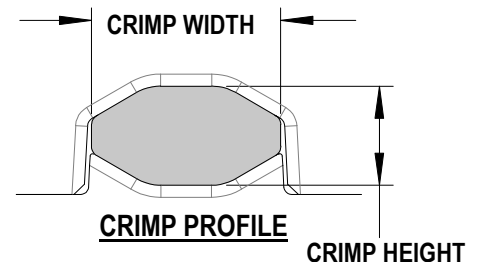

Terminal Series No.	Wire Size		Crimp Height (Ref)		Crimp Width (Ref)	
	AWG	Wire Style	mm	In.	mm	In.
171423 / 171562	1/0	Post-Tinned	8.70-8.90	.342-.350	13.05-13.25	.514-.522

The following is a Partial List of the Product Part Numbers and their specifications that this tooling is designed to crimp. We will be adding to this list and an up to date copy is available on www.molex.com.

Terminal Series	Terminal No.	Wire Size (AWG)	Wire Strands / AWG	Wire Strip Length	
				In	mm
171423	171423-1200	1/0	1007 / 30 post tinned	.87	22
	171423-1201	1/0	1007 / 30 post tinned	.87	22
171562	171562-1200	1/0	1007 / 30 post tinned	.87	22
	171562-1201	1/0	1007 / 30 post tinned	.87	22

CAUTION: Molex crimp specifications are valid only when used with Molex terminals and tooling.

Parts List

Item	Order No.	Description	Qty
	19290-0200	Crimp Tooling Kit	REF
1	19290-0201	Conductor Anvil	1
2	19290-0202	Conductor Punch	1

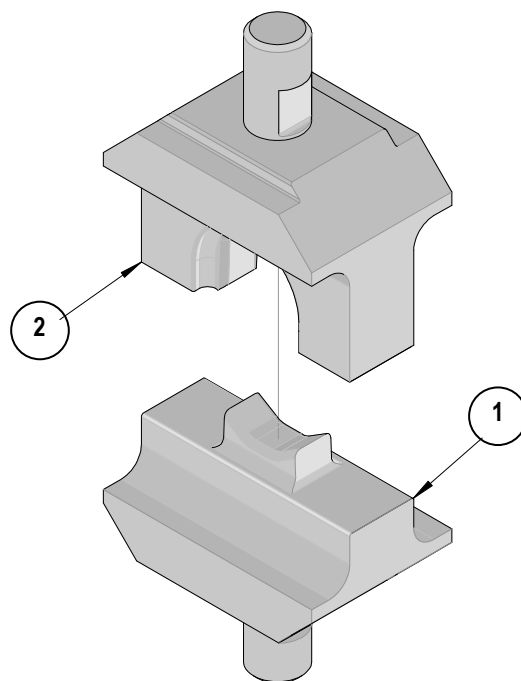

Visit our Web site at <http://www.molex.com>