

# SN55ALS161, SN75ALS161 OCTAL GENERAL-PURPOSE INTERFACE BUS TRANSCEIVERS

SLLS019D – JUNE 1986 – REVISED MAY 1995

## SUITABLE FOR IEEE STANDARD 488-1978 (GPIB)<sup>†</sup>

- 8-Channel Bidirectional Transceiver
- Designed to Implement Control Bus Interface
- Designed for Single Controller
- High-Speed Advanced Low-Power Schottky Circuitry
- Low Power Dissipation:  
SN55ALS161 . . . 59 mW Max Per Channel  
SN75ALS161 . . . 48 mW Max Per Channel
- Fast Propagation Times:  
SN55ALS161 . . . 25 ns Max  
SN75ALS161 . . . 20 ns Max
- High-impedance pnp Inputs
- Receiver Hysteresis:  
SN55ALS161 . . . 550 mV Typ  
SN75ALS161 . . . 650 mV Typ
- Bus-Terminating Resistors Provided on Driver Outputs
- No Loading of Bus When Device Is Powered Down ( $V_{CC} = 0$ )
- Power-Up/Power-Down Protection (Glitch Free)

### description

The SN55ALS161 and SN75ALS161 eight-channel general-purpose interface bus transceivers are monolithic, high-speed, advanced low-power Schottky process devices designed to provide the bus-management and data-transfer signals between operating units of a single controller instrumentation system. When combined with the SN55ALS160 and SN75ALS160 octal bus transceivers, the 'ALS161 provides the complete 16-wire interface for the IEEE 488 bus.

The SN55ALS161 and SN75ALS161 feature eight driver-receiver pairs connected in a front-to-back configuration to form input/output (I/O) ports at both the bus and terminal sides. The direction of data through these driver-receiver pairs is determined by the DC and TE enable signals.

The driver outputs general-purpose interface bus (GPIB I/O ports) feature active bus-terminating resistor circuits designed to provide a high impedance to the bus when  $V_{CC} = 0$ . The drivers are designed to handle loads up to 48 mA of sink current. Each receiver features pnp transistor inputs for high input impedance and hysteresis of 400 mV on the commercial part, 250 mV on the military part minimum for increased noise immunity. All receivers have 3-state outputs to present a high impedance to the terminal when disabled.

<sup>†</sup> The transceivers are suitable for IEEE Standard 488 applications to the extent of the operating conditions and characteristics specified in this data sheet. Certain limits contained in the IEEE specification are not met or cannot be tested over the entire military temperature range.

SN55ALS161 . . . J OR W PACKAGE  
SN75ALS161 . . . DW OR N PACKAGE  
(TOP VIEW)

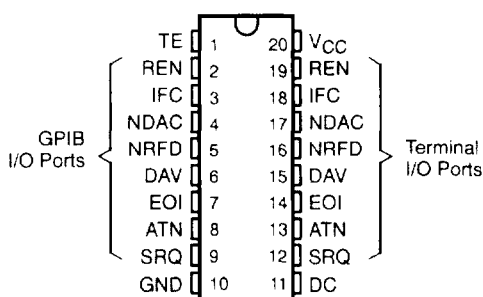

SN55ALS161 . . . FK PACKAGE  
(TOP VIEW)

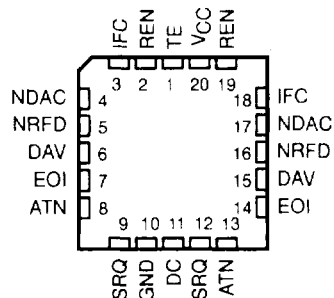

CHANNEL IDENTIFICATION TABLE

NAME	IDENTITY	CLASS
DC	Direction Control	Control
TE	Talk Enable	
ATN	Attention	Bus Management
SRQ	Service Request	
REN	Remote Enable	
IFC	Interface Clear	
EOI	End or Identify	
DAV	Data Valid	Data Transfer
NDAC	Not Data Accepted	
NRFD	Not Ready for Data	

PRODUCTION DATA Information is current as of publication date. Products conform to specifications per the terms of Texas Instruments standard warranty. Production processing does not necessarily include testing of all parameters.



Copyright © 1995, Texas Instruments Incorporated

POST OFFICE BOX 655303 • DALLAS, TEXAS 75265

# SN55ALS161, SN75ALS161 OCTAL GENERAL-PURPOSE INTERFACE BUS TRANSCEIVERS

SLLS019D - JUNE 1986 - REVISED MAY 1995

## description (continued)

The SN55ALS161 is characterized for operation from  $-55^{\circ}\text{C}$  to  $125^{\circ}\text{C}$ . The SN75ALS161 is characterized for operation from  $0^{\circ}\text{C}$  to  $70^{\circ}\text{C}$ .

## logic symbol

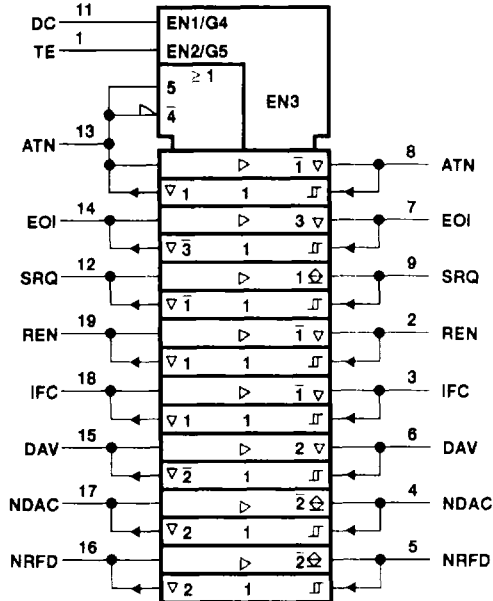

† This symbol is in accordance with ANSI/IEEE Std 91-1984 and IEC Publication 617-12.

▽ Designates 3-state outputs

⊕ Designates passive-pullup outputs

## logic diagram (positive logic)

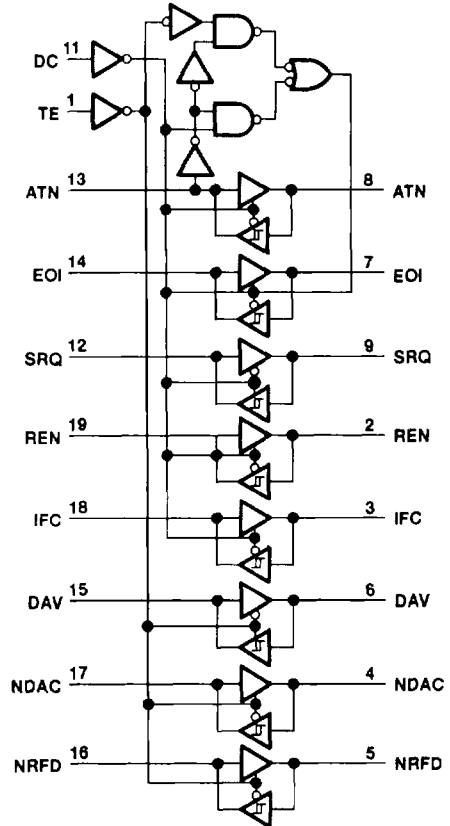

# SN55ALS161, SN75ALS161 OCTAL GENERAL-PURPOSE INTERFACE BUS TRANSCEIVERS

SLLS019D - JUNE 1986 - REVISED MAY 1995

**RECEIVE/TRANSMIT FUNCTION TABLE**

CONTROLS			BUS-MANAGEMENT CHANNELS					DATA-TRANSFER CHANNELS		
DC	TE	ATN†	ATN†	SRQ (controlled by DC)	REN	IFC	EOI	DAV	NDAC	NRFD (controlled by TE)
H	H	H	R	T	R	R	T	T	R	R
H	H	L					R			
L	L	H	T	R	T	T	R	T	T	T
L	L	L					T			
H	L	X	R	T	R	R	R	R	T	T
L	H	X	T	R	T	T	T	T	R	R

H = high level, L = low level, R = receive, T = transmit, X = irrelevant

Direction of data transmission is from the terminal side to the bus side, and the direction of data receiving is from the bus side to the terminal side. Data transfer is noninverting in both directions.

† ATN is a normal transceiver channel that functions additionally as an internal direction control or talk enable for EOI whenever the DC and TE inputs are in the same state. When DC and TE are in opposite states, the ATN channel functions as an independent transceiver only.



POST OFFICE BOX 655303 • DALLAS, TEXAS 75265

2-385

# SN55ALS161, SN75ALS161 OCTAL GENERAL-PURPOSE INTERFACE BUS TRANSCEIVERS

SLLS019D – JUNE 1986 – REVISED MAY 1995

## schematics of inputs and outputs

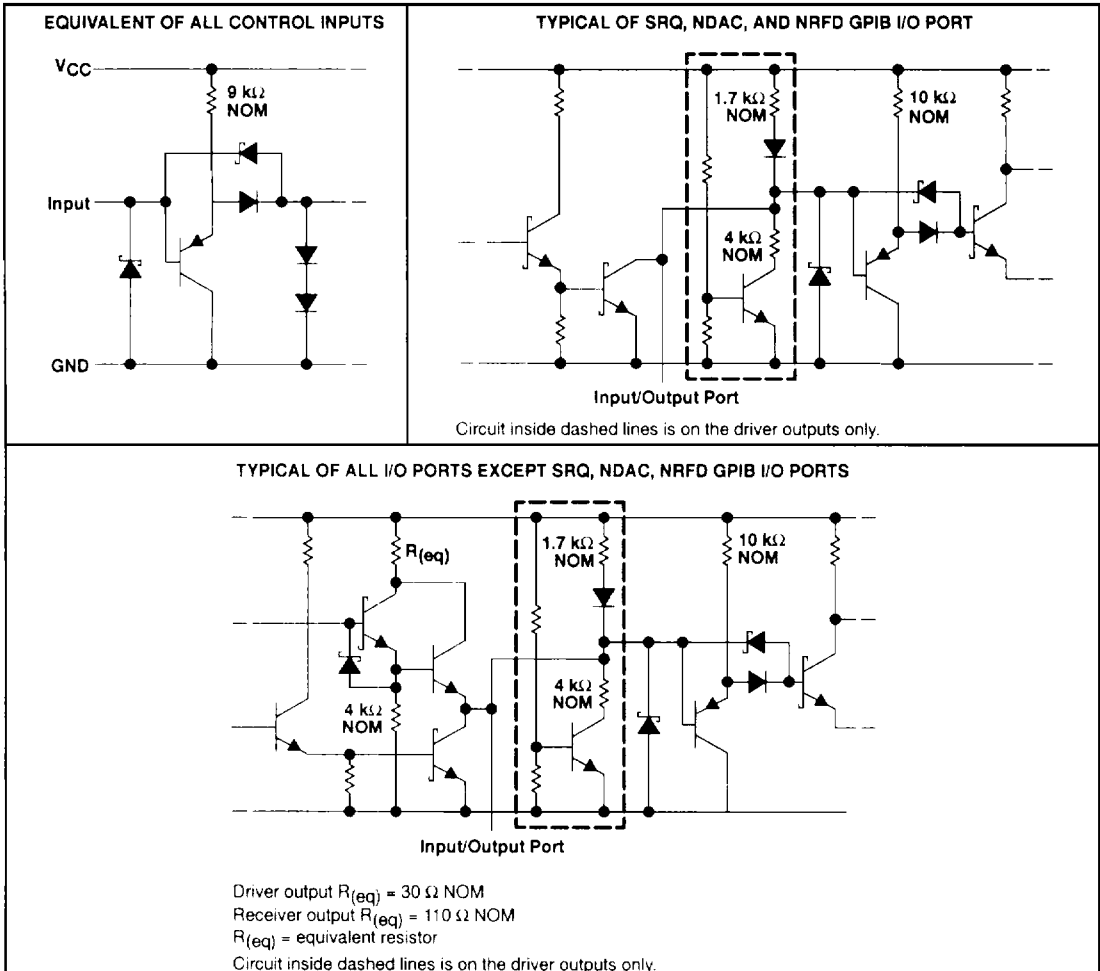

# SN55ALS161, SN75ALS161 OCTAL GENERAL-PURPOSE INTERFACE BUS TRANSCEIVERS

SLLS019D – JUNE 1986 – REVISED MAY 1995

## absolute maximum ratings over operating free-air temperature range (unless otherwise noted)†

Supply voltage, $V_{CC}$ (see Note 1)	7 V
Input voltage, $V_I$	5.5 V
Low-level driver output current, $I_{OL}$	100 mA
Continuous total dissipation	See Dissipation Rating Table
Operating free-air temperature range, $T_A$ : SN55ALS161	–55°C to 125°C
SN75ALS161	0°C to 70°C
Storage temperature range, $T_{stg}$	–65°C to 150°C
Case temperature for 60 seconds: FK package, $T_C$	260°C
Lead temperature 1,6 mm (1/16 inch) from the case for 60 seconds: J or W package	300°C
Lead temperature 1,6 mm (1/16 inch) from the case for 10 seconds: DW or N package	260°C

† Stresses beyond those listed under “absolute maximum ratings” may cause permanent damage to the device. These are stress ratings only, and functional operation of the device at these or any other conditions beyond those indicated under “recommended operating conditions” is not implied. Exposure to absolute-maximum-rated conditions for extended periods may affect device reliability.

NOTE 1: All voltage values are with respect to network ground terminal.

**DISSIPATION RATING TABLE**

PACKAGE	$T_A \leq 25^\circ\text{C}$ POWER RATING	OPERATING FACTOR	$T_A = 70^\circ\text{C}$ POWER RATING	$T_A = 125^\circ\text{C}$ POWER RATING
DW	1125 mW	9.0 mW/°C	720 mW	—
FK	1375 mW	11.0 mW/°C	880 mW	275 mW
J	1375 mW	11.0 mW/°C	880 mW	275 mW
N	1150 mW	9.2 mW/°C	736 mW	—
W	1000 mW	8.0 mW/°C	640 mW	200 mW

## SN55ALS161 recommended operating conditions

		MIN	NOM	MAX	UNIT
Supply voltage, $V_{CC}$		4.75	5	5.25	V
High-level input voltage, $V_{IH}$	TE and DC at $T_A = -55^\circ\text{C}$ to $125^\circ\text{C}$	2			V
	Bus and terminal at $T_A = 25^\circ\text{C}$ to $125^\circ\text{C}$	2			
	Bus and terminal at $T_A = -55^\circ\text{C}$	2.1			
Low-level input voltage, $V_{IL}$	TE and DC at $T_A = -55^\circ\text{C}$ to $125^\circ\text{C}$	0.8			V
	Bus and terminal at $T_A = 25^\circ\text{C}$ to $-55^\circ\text{C}$	0.8			
	Bus and terminal at $T_A = 125^\circ\text{C}$	0.7			
High-level output current, $I_{OH}$	Bus ports with pullups active ( $V_{CC} = 5\text{ V}$ )	– 5.2			mA
	Terminal ports	– 800			$\mu\text{A}$
Low-level output current, $I_{OL}$	Bus ports	48			mA
	Terminal ports	16			
Operating free-air temperature, $T_A$		–55		125	°C



POST OFFICE BOX 655303 • DALLAS, TEXAS 75265

# SN55ALS161, SN75ALS161 OCTAL GENERAL-PURPOSE INTERFACE BUS TRANSCEIVERS

SLLS019D - JUNE 1986 - REVISED MAY 1995

## SN75ALS161 recommended operating conditions

	MIN	NOM	MAX	UNIT
Supply voltage, $V_{CC}$	4.75	5	5.25	V
High-level input voltage, $V_{IH}$	2			V
Low-level input voltage, $V_{IL}$			0.8	V
High-level output current, $I_{OH}$	Bus ports with pullups active		-5.2	mA
	Terminal ports		-800	$\mu$ A
Low-level output current, $I_{OL}$	Bus ports		48	mA
	Terminal ports		16	
Operating free-air temperature, $T_A$	0		70	$^{\circ}$ C

# SN55ALS161, SN75ALS161 OCTAL GENERAL-PURPOSE INTERFACE BUS TRANSCEIVERS

SLLS019D - JUNE 1986 - REVISED MAY 1995

electrical characteristics over recommended ranges of supply voltage and operating free-air temperature (unless otherwise noted)

PARAMETER	TEST CONDITIONST	SN55ALS161		SN75ALS161		UNIT	
		MIN	TYP†	MAX	MIN		TYP†
$V_{IK}$	Input clamp voltage	$I_I = -18 \text{ mA}$					V
$V_{hys}$	Hysteresis voltage ( $V_{IT+} - V_{IT-}$ )	$V_{CC} = 5 \text{ V}$ , $T_A = -55^\circ\text{C}$ and $25^\circ\text{C}$					V
		$V_{CC} = 5 \text{ V}$ , $T_A = 125^\circ\text{C}$					
$V_{OH}^{\S}$	High-level output voltage	Terminal $I_{OH} = -800 \mu\text{A}$					V
		Bus $I_{OH} = -5.2 \text{ mA}$ , $V_{CC} = 5 \text{ V}$ (SN55)					
$V_{OL}$	Low-level output voltage	Terminal $I_{OL} = 16 \text{ mA}$ , $V_{CC} = \text{MIN}$					V
		Bus $I_{OL} = 48 \text{ mA}$ , $V_{CC} = \text{MIN}$					
$I_I$	Input current at maximum input voltage	$V_I = 5.5 \text{ V}$ , $V_{CC} = \text{MAX}$					$\mu\text{A}$
$I_{IH}$	High-level input current	$V_I = 2.7 \text{ V}$ , $V_{CC} = \text{MAX}$					$\mu\text{A}$
$I_{IL}$	Low-level input current	$V_I = 0.5 \text{ V}$ , $V_{CC} = \text{MAX}$					$\mu\text{A}$
$V_{IO}$	Voltage at GPIB I/O port	Driver disabled, $V_{CC} = 5 \text{ V}$ (SN55†)					V
		$I_I(\text{bus}) = 0$ $I_I(\text{bus}) = -12 \text{ mA}$					
$I_{IO}$	Current into GPIB I/O port	$V_I(\text{bus}) = -1.5 \text{ V}$ to $0.4 \text{ V}$					mA
		$V_I(\text{bus}) = 0.4 \text{ V}$ to $2.5 \text{ V}$					
		$V_I(\text{bus}) = 2.5 \text{ V}$ to $3.7 \text{ V}$					
		$V_I(\text{bus}) = 3.7 \text{ V}$ to $5 \text{ V}$					
		$V_I(\text{bus}) = 5 \text{ V}$ to $5.5 \text{ V}$					
$I_{OS}^{\S}$	Short-circuit output current	$V_{CC} = 0$					$\mu\text{A}$
		$V_{CC} = \text{MAX}$					
$I_{CC}$	Supply current	No load, $V_{CC} = 0$ to $5 \text{ V}$ , $V_{IO} = 0$ to $2 \text{ V}$ , $f = 1 \text{ MHz}$					mA
		TE and DC low, $V_{CC} = \text{MAX}$					
$C_{IO}$	GPIB I/O port capacitance	$V_{IO} = 0$ to $2 \text{ V}$ , $f = 1 \text{ MHz}$					pF

† For conditions shown as MIN or MAX, use the appropriate value specified under recommended operating conditions.

‡ All typical values are at  $V_{CC} = 5 \text{ V}$ ,  $T_A = 25^\circ\text{C}$ .

§  $V_{OH}$  and  $I_{OS}$  apply to 3-state outputs only.



POST OFFICE BOX 655303 • DALLAS, TEXAS 75265

# SN55ALS161, SN75ALS161 OCTAL GENERAL-PURPOSE INTERFACE BUS TRANSCEIVER

SLLS019D - JUNE 1986 - REVISED MAY 1995

## SN55ALS161 switching characteristics, $V_{CC} = 5\text{ V}$ and $C_L = 50\text{ pF}$ (unless otherwise noted)

PARAMETER	FROM (INPUT)	TO (OUTPUT)	TEST CONDITIONS	$T_A$ †	MIN	TYP‡	MAX	UNIT
t <sub>PLH</sub> Propagation delay time, low- to high-level output	Terminal	Bus (Except SRQ, NDAC, and NRFD)	See Figure 1	25°C	10	17	ns	
				Full range		20		
t <sub>PHL</sub> Propagation delay time, high- to low-level output	Terminal	Bus (NRFD, SRQ, NDAC)	See Figure 2	25°C	10	14	ns	
				Full range		16		
t <sub>PLH</sub> Propagation delay time, low- to high-level output	Terminal	Bus (NRFD, SRQ, NDAC)	See Figure 2	25°C		25	ns	
				Full range		30		
t <sub>PHL</sub> Propagation delay time, high- to low-level output	Terminal	Bus (NRFD, SRQ, NDAC)	See Figure 2	25°C	10	14	ns	
				Full range		16		
t <sub>PLH</sub> Propagation delay time, low- to high-level output	Bus	Terminal	See Figure 2	25°C	10	15	ns	
				Full range		18		
t <sub>PHL</sub> Propagation delay time, high- to low-level output	Bus	Terminal	See Figure 2	25°C	10	15	ns	
				Full range		18		
t <sub>PZH</sub> Output enable time to high level	TE or DC	Bus (ATN, REN, IFC, and DAV)	See Figure 3	25°C	20	30	ns	
t <sub>PHZ</sub> Output disable time from high level				Full range		41		
				25°C	8	14		
t <sub>PZL</sub> Output enable time to low level				Full range		16		
				25°C	16	28		
t <sub>PLZ</sub> Output disable time from low level				Full range		34		
				25°C	10	19		
t <sub>PZH</sub> Output enable time to high level				TE or DC	Bus (EOI)	See Figure 3		Full range
	25°C	24	30					
t <sub>PHZ</sub> Output disable time from high level	TE or DC	Bus (EOI)	See Figure 3	Full range		48	ns	
				25°C	13	19		
t <sub>PZL</sub> Output enable time to low level,	TE or DC	Bus (EOI)	See Figure 3	Full range		25	ns	
				25°C	21	35		
t <sub>PLZ</sub> Output disable time from low level	TE or DC	Bus (EOI)	See Figure 3	Full range		43	ns	
				25°C	13	20		
t <sub>PZH</sub> Output enable time to high level	TE or DC	Terminal	See Figure 4	25°C	24	36	ns	
				Full range		50		
t <sub>PHZ</sub> Output disable time from high level				25°C	12	20		
				Full range		33		
t <sub>PZL</sub> Output enable time to low level				25°C	20	34		
				Full range		41		
t <sub>PLZ</sub> Output disable time from low level				25°C	13	24		
				Full range		35		

† Full range is -55°C to 125°C.

‡ All typical values are at  $V_{CC} = 5\text{ V}$ .





# SN55ALS161, SN55ALS161 OCTAL GENERAL-PURPOSE INTERFACE BUS TRANSCEIVER

SLLS019D - JUNE 1986 - REVISED MAY 1995

**SN75ALS161 switching characteristics over recommended operating free-air temperature range,  $V_{CC} = 5\text{ V}$**

PARAMETER	FROM (INPUT)	TO (OUTPUT)	TEST CONDITIONS	MIN	TYP†	MAX	UNIT
$t_{PLH}$ Propagation delay time, low- to high-level output	Terminal	Bus	$C_L = 30\text{ pF}$ , See Figure 1		10	20	ns
$t_{PHL}$ Propagation delay time, high- to low-level output					12	20	
$t_{PLH}$ Propagation delay time, low- to high-level output	Bus	Terminal	$C_L = 30\text{ pF}$ , See Figure 2		5	10	ns
$t_{PHL}$ Propagation delay time, high- to low-level output					7	14	
$t_{pZH}$ Output enable time to high level	TE or DC	Bus (ATN, EOI, REN, IFC, and DAV)	$C_L = 15\text{ pF}$ , See Figure 3			30	ns
$t_{pHZ}$ Output disable time from high level						20	
$t_{pZL}$ Output enable time to low level						45	
$t_{pZL}$ Output disable time from low level						20	
$t_{pZH}$ Output enable time to high level	TE or DC	Terminal	$C_L = 15\text{ pF}$ , See Figure 4			30	ns
$t_{pHZ}$ Output disable time from high level						25	
$t_{pZL}$ Output enable time to low level						30	
$t_{pZL}$ Output disable time from low level						25	

† All typical values are at  $T_A = 25^\circ\text{C}$ .

## PARAMETER MEASUREMENT INFORMATION

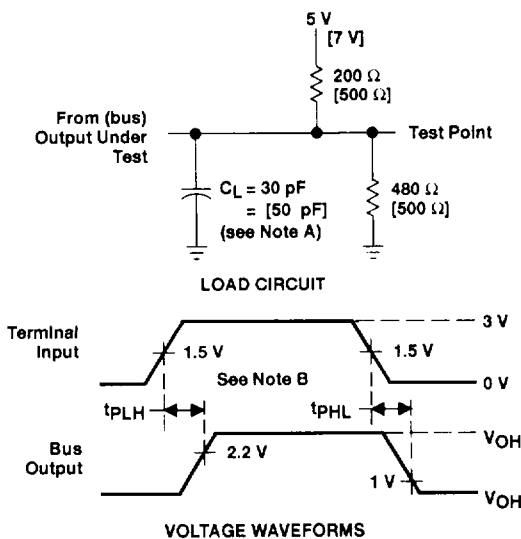

**Figure 1. Terminal-to-Bus Load Circuit and Voltage Waveforms**

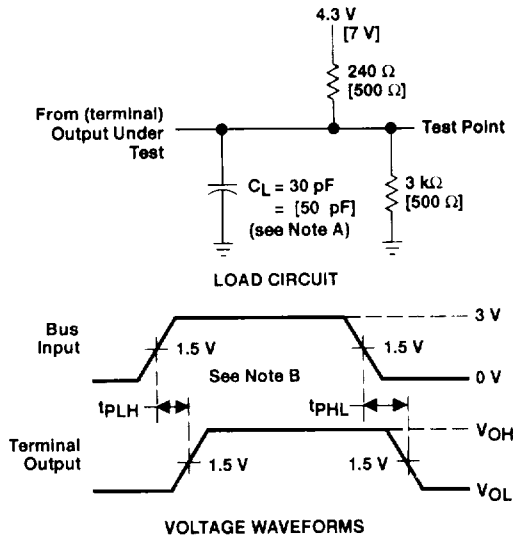

**Figure 2. Bus-to-Terminal Load Circuit and Voltage Waveforms**

[ ] denotes the SN55ALS161 military test conditions.

NOTES: A.  $C_L$  includes probe and jig capacitance.

B. The input pulse is supplied by a generator having the following characteristics:  $PRR \leq 1\text{ MHz}$ , 50% duty cycle,  $t_r \leq 6\text{ ns}$ ,  $t_f \leq 6\text{ ns}$ ,  $Z_O = 50\ \Omega$ .



POST OFFICE BOX 655303 • DALLAS, TEXAS 75265

# SN55ALS161, SN75ALS161 OCTAL GENERAL-PURPOSE INTERFACE BUS TRANSCEIVER

SLLS019D - JUNE 1986 - REVISED MAY 1995

## PARAMETER MEASUREMENT INFORMATION

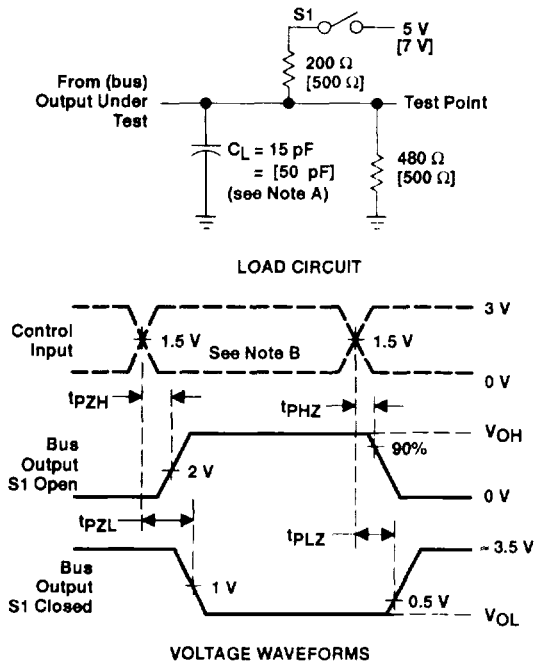

**Figure 3. Bus Load Circuit and Voltage Waveforms**

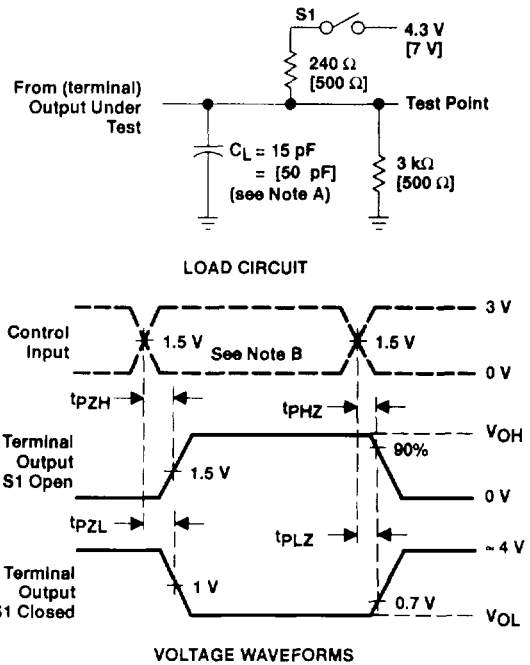

**Figure 4. Terminal Load Circuit and Voltage Waveforms**

[ ] denotes the SN55ALS161 military test conditions.

NOTES: A.  $C_L$  includes probe and jig capacitance.

B. The input pulse is supplied by a generator having the following characteristics: PRR < 1 MHz, 50% duty cycle,  $t_r \leq 6$  ns,  $t_f \leq 6$  ns,  $Z_O = 50 \Omega$ .

# SN55ALS161, SN55ALS161 OCTAL GENERAL-PURPOSE INTERFACE BUS TRANSCEIVER

SLLS019D - JUNE 1986 - REVISED MAY 1995

## TYPICAL CHARACTERISTICS

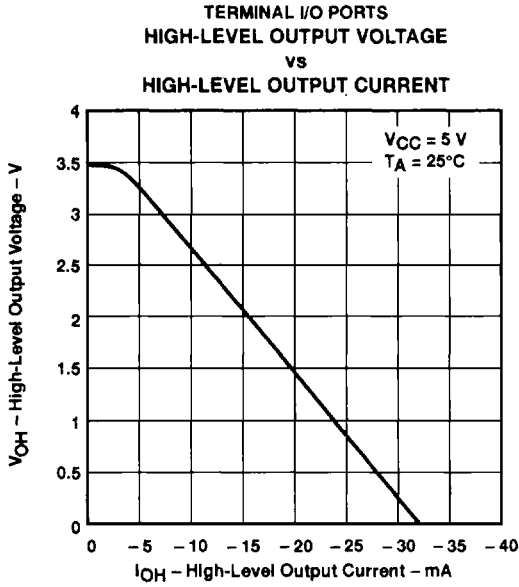

Figure 5

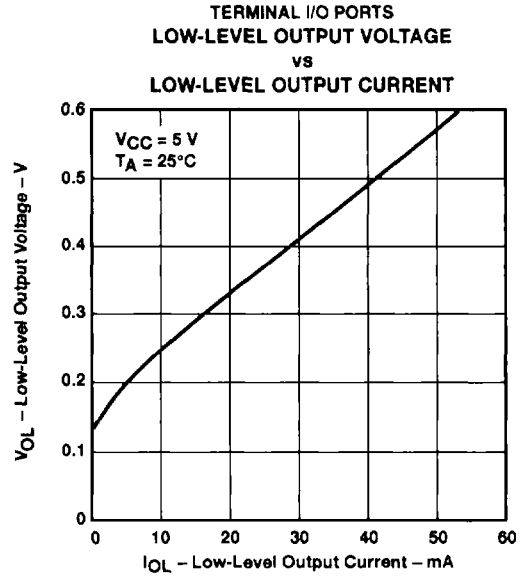

Figure 6

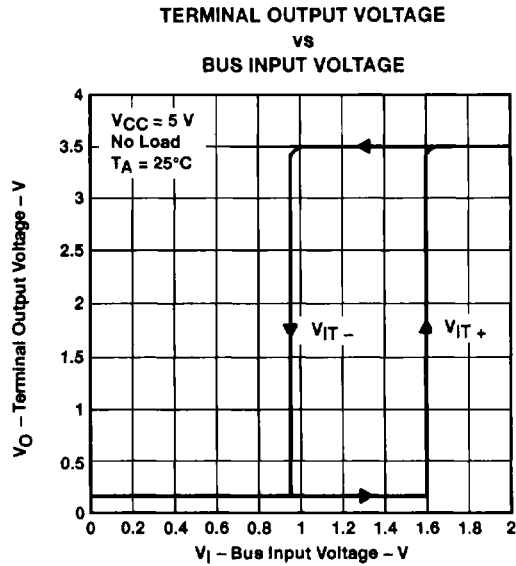

Figure 7

**TEXAS  
INSTRUMENTS**

POST OFFICE BOX 655303 • DALLAS, TEXAS 75265

# SN55ALS161, SN75ALS161 OCTAL GENERAL-PURPOSE INTERFACE BUS TRANSCEIVER

SLLS019D - JUNE 1986 - REVISED MAY 1995

## TYPICAL CHARACTERISTICS

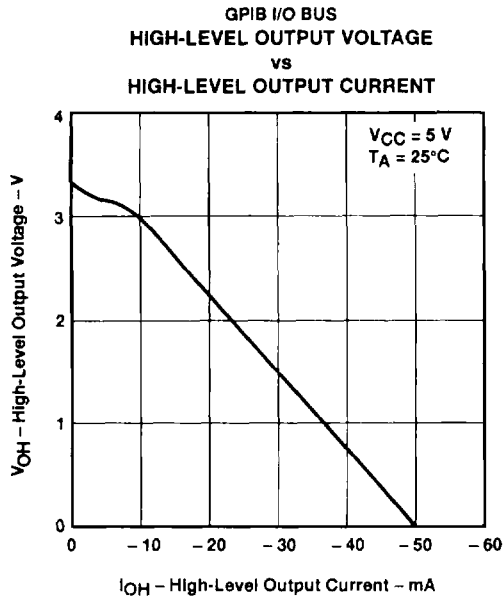

Figure 8

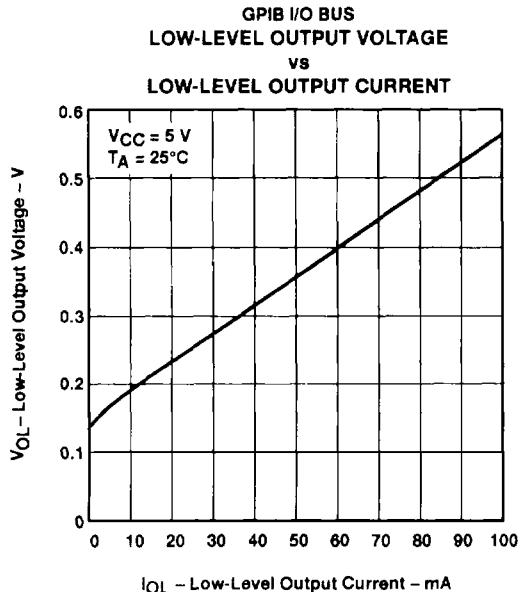

Figure 9

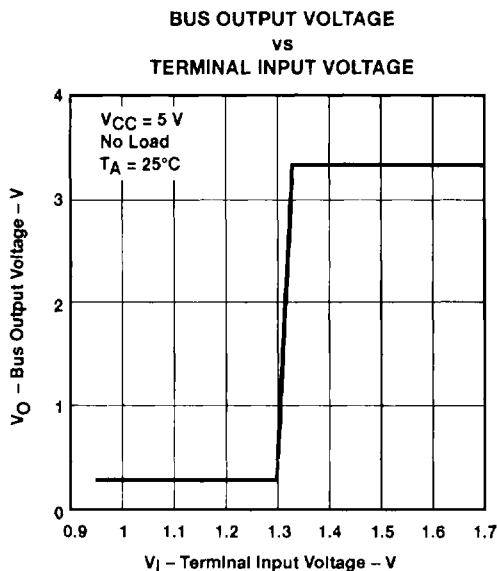

Figure 10

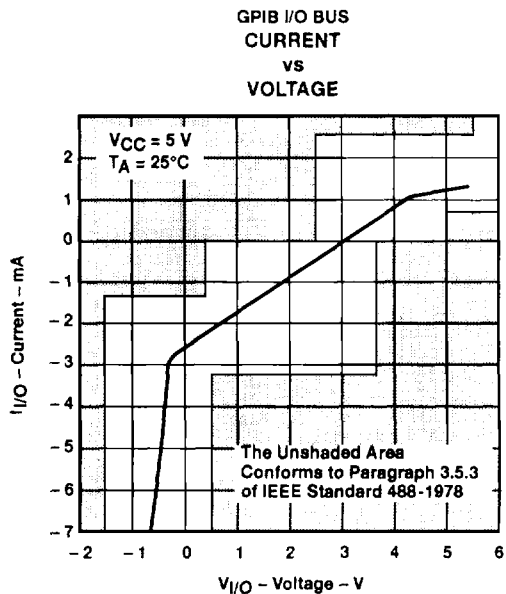

Figure 11