

## CD4070BC Quad 2-Input EXCLUSIVE-OR Gate

### General Description

The CD4070BC employs complementary MOS (CMOS) transistors to achieve wide power supply operating range, low power consumption, and high noise margin, the CD4070BC provide basic functions used in the implementation of digital integrated circuit systems. The N- and P-channel enhancement mode transistors provide a symmetrical circuit with output swing essentially equal to the supply voltage. No DC power other than that caused by leakage current is consumed during static condition. All inputs are

protected from damage due to static discharge by diode clamps to  $V_{DD}$  and  $V_{SS}$ .

### Features

- Wide supply voltage range: 3.0V to 15V
- High noise immunity: 0.45  $V_{DD}$  typ.
- Low power TTL compatibility:  
Fan out of 2 driving 74L or 1 driving 74LS
- Pin compatible to CD4030A  
Equivalent to MM74C86 and MC14070B

### Ordering Code:

Order Number	Package Number	Package Description
CD4070BCM	M14A	14-Lead Small Outline Integrated Circuit (SOIC), JEDEC MS-120, 0.150" Narrow Body
CD4070BCN	N14A	14-Lead Plastic Dual-In-Line Package (PDIP), JEDEC MS-001, 0.300" Wide

Devices also available in Tape and Reel. Specify by appending the suffix letter "X" to the ordering code.

### Connection Diagram

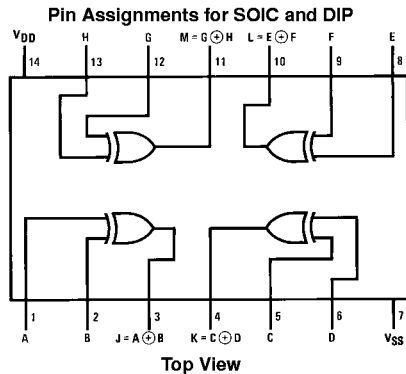

### Truth Table

Inputs		Outputs
A	B	Y
L	L	L
L	H	H
H	L	H
H	H	L

**Absolute Maximum Ratings** (Note 1)

(Note 2)

DC Supply Voltage ( $V_{DD}$ )	-0.5 to +18 $V_{DC}$
Input Voltage ( $V_{IN}$ )	-0.5 to $V_{DD}$ +0.5 $V_{DC}$
Storage Temperature Range ( $T_S$ )	-65°C to +150°C
Power Dissipation ( $P_D$ )	
Dual-In-Line	700 mW
Small Outline	500 mW
Lead Temperature ( $T_L$ )	
(Soldering, 10 seconds)	260°C

**Recommended Operating Conditions** (Note 2)

DC Supply Voltage ( $V_{DD}$ )	3V to 15 $V_{DC}$
Input Voltage ( $V_{IN}$ )	0 to $V_{DD}$ $V_{DC}$
Operating Temperature Range ( $T_A$ )	-40°C to +85°C

**Note 1:** "Absolute Maximum Ratings" are those values beyond which the safety of the device cannot be guaranteed. They are not meant to imply that the devices should be operated at these limits. The table of "Recommended Operating Conditions" and "Electrical Characteristics" provides conditions for actual device operation.

**Note 2:**  $V_{SS} = 0V$  unless otherwise specified.

**DC Electrical Characteristics** (Note 3)

Symbol	Parameter	Conditions	-40°C		+25°C			+85°C		Units
			Min	Max	Min	Typ	Max	Min	Max	
$I_{DD}$	Quiescent Device Current	$V_{DD} = 5V$ , $V_{IN} = V_{DD}$ or $V_{SS}$		1.0			1.0		7.5	$\mu A$
		$V_{DD} = 10V$ , $V_{IN} = V_{DD}$ or $V_{SS}$		2.0			2.0		15	$\mu A$
		$V_{DD} = 15V$ , $V_{IN} = V_{DD}$ or $V_{SS}$		4.0			4.0		30	$\mu A$
$V_{OL}$	LOW Level Output Voltage	$ I_{OL}  < 1 \mu A$ $V_{DD} = 5V$		0.05		0	0.05		0.05	V
		$V_{DD} = 10V$		0.05		0	0.05		0.05	V
		$V_{DD} = 15V$		0.05		0	0.05		0.05	V
$V_{OH}$	HIGH Level Output Voltage	$ I_{OH}  < 1 \mu A$ $V_{DD} = 5V$	4.95		4.95	5		4.95		V
		$V_{DD} = 10V$	9.95		9.95	10		9.95		V
		$V_{DD} = 15V$	14.95		14.95	15		14.95		V
$V_{IL}$	LOW Level Input Voltage	$ I_{IL}  < 1 \mu A$ $V_{DD} = 5V$ , $V_O = 4.5V$ or $0.5V$		1.5			1.5		1.5	V
		$V_{DD} = 10V$ , $V_O = 9V$ or $1.0V$		3.0			3.0		3.0	V
		$V_{DD} = 15V$ , $V_O = 13.5V$ or $1.5V$		4.0			4.0		4.0	V
$V_{IH}$	HIGH Level Input Voltage	$ I_{IH}  < 1 \mu A$ $V_{DD} = 5V$ , $V_O = 0.5V$ or $4.5V$	3.5		3.5			3.5		V
		$V_{DD} = 10V$ , $V_O = 1V$ or $9.0V$	7.0		7.0			7.0		V
		$V_{DD} = 15V$ , $V_O = 1.5V$ or $13.5V$	11.0		11.0			11.0		V
$I_{OL}$	LOW Level Output Current	$V_{DD} = 5V$ , $V_O = 0.4V$	0.52		0.44	0.88		0.36		mA
		$V_{DD} = 10V$ , $V_O = 0.5V$	1.3		1.1	2.25		0.9		mA
		$V_{DD} = 15V$ , $V_O = 1.5V$	3.6		3.0	8.8		2.4		mA
$I_{OH}$	HIGH Level Output Current	$V_{DD} = 5V$ , $V_O = 4.6V$	-0.52		-0.44	-0.88		-0.36		mA
		$V_{DD} = 10V$ , $V_O = 9.5V$	-1.3		-1.1	-2.25		-0.9		mA
		$V_{DD} = 15V$ , $V_O = 13.5V$	-3.6		-3.0	-8.8		-2.4		mA
$I_{IN}$	Input Current	$V_{DD} = 15V$ , $V_{IN} = 0V$		-0.3		$-10^{-5}$	-0.3		-1.0	$\mu A$
		$V_{DD} = 15V$ , $V_{IN} = 15V$		0.3		$10^{-5}$	0.3		1.0	$\mu A$

**Note 3:** "Absolute Maximum Ratings" are those values beyond which the safety of the device cannot be guaranteed. They are not meant to imply that the devices should be operated at these limits. The table of "Recommended Operating Conditions" and "Electrical Characteristics" provides conditions for actual device operation.

## AC Electrical Characteristics (Note 4)

$T_A = 25^\circ\text{C}$ ,  $C_L = 50\text{ pF}$ ,  $R_L = 200\text{ k}$ ,  $t_r$  and  $t_f \leq 20\text{ ns}$ , unless otherwise specified

Symbol	Parameter	Conditions	Min	Typ	Max	Units
$t_{PHL}$ or $t_{PLH}$	Propagation Delay Time from Input to Output	$V_{DD} = 5\text{V}$ $V_{DD} = 10\text{V}$ $V_{DD} = 15\text{V}$		110 50 40	185 90 75	ns
$t_{THL}$ or $t_{TLH}$	Transition Time	$V_{DD} = 5\text{V}$ $V_{DD} = 10\text{V}$ $V_{DD} = 15\text{V}$		100 50 40	200 100 80	ns
$C_{IN}$	Average Input Capacitance	Any Input		5	7.5	pF
$C_{PD}$	Power Dissipation Capacitance	Any Input (Note 5)		20		pF

**Note 4:** AC Parameters are guaranteed by DC correlated testing.

**Note 5:**  $C_{PD}$  determines the no load AC power consumption of any CMOS device. For complete explanation, see 74C Family Characteristics Application Note—AN-90.

## Typical Performance Characteristics

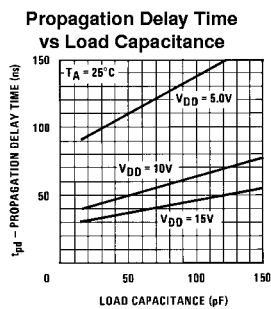

## AC Test Circuit and Switching Time Waveforms

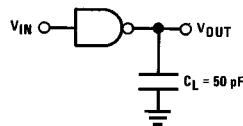

**Note:** Delays measured with input  $t_r$ ,  $t_f = 20\text{ ns}$ .

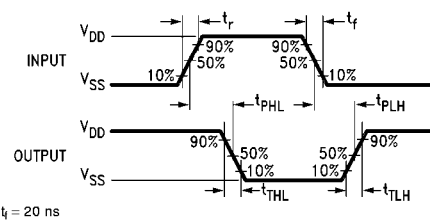

**Physical Dimensions** inches (millimeters) unless otherwise noted

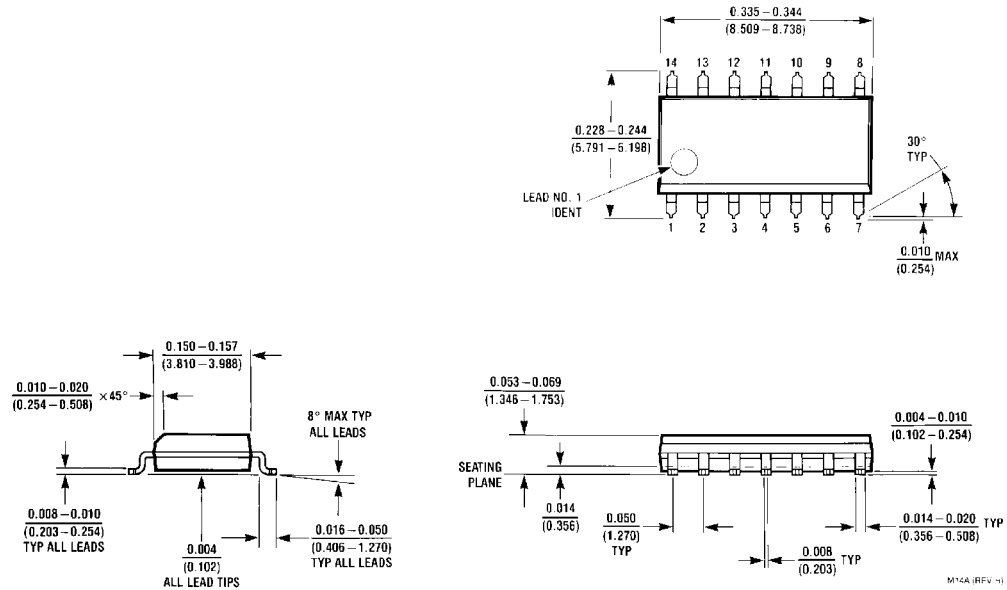

**14-Lead Small Outline Integrated Circuit (SOIC), JEDEC MS-120, 0.150" Narrow Body  
Package Number M14A**

**Physical Dimensions** inches (millimeters) unless otherwise noted (Continued)

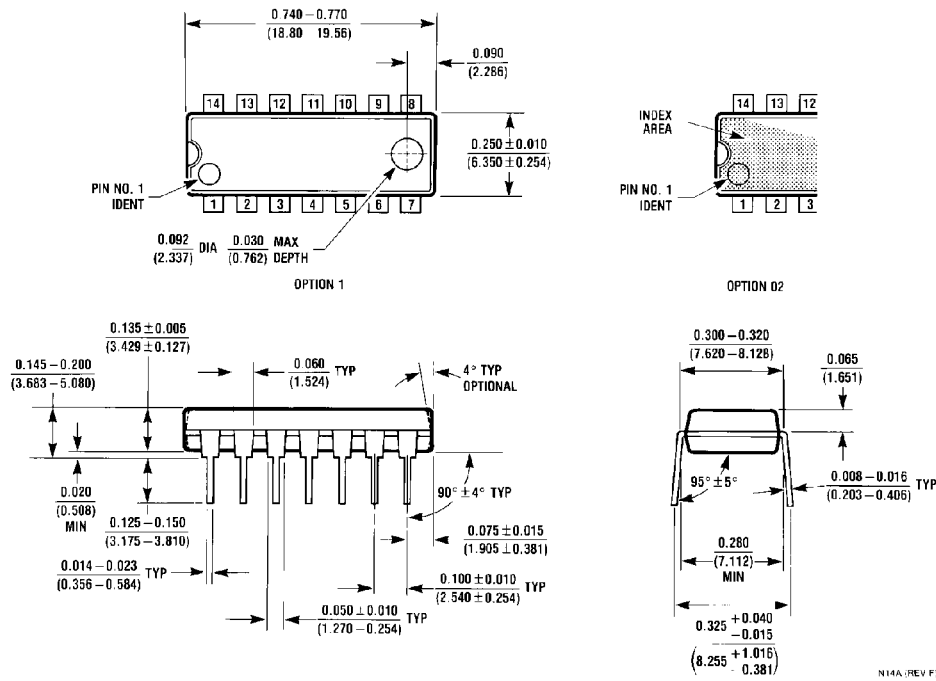

**LIFE SUPPORT POLICY**

FAIRCHILD'S PRODUCTS ARE NOT AUTHORIZED FOR USE AS CRITICAL COMPONENTS IN LIFE SUPPORT DEVICES OR SYSTEMS WITHOUT THE EXPRESS WRITTEN APPROVAL OF THE PRESIDENT OF FAIRCHILD SEMICONDUCTOR CORPORATION. As used herein:

1. Life support devices or systems are devices or systems which, (a) are intended for surgical implant into the body, or (b) support or sustain life, and (c) whose failure to perform when properly used in accordance with instructions for use provided in the labeling, can be reasonably expected to result in a significant injury to the user.
2. A critical component in any component of a life support device or system whose failure to perform can be reasonably expected to cause the failure of the life support device or system, or to affect its safety or effectiveness.

[www.fairchildsemi.com](http://www.fairchildsemi.com)