

AEVT350 Series DC Contactor Specification



c us
UL FILE NUMBER: E501749

Application

- Operating voltage range: 12-1,800VDC, continuous 350A, break current of 2,300A
- Ideal for Circuit protection, control, battery switch and main power break, etc.
- Built-in coil economizer:
 - Holding power @4W with no limitation of temperature and voltage
 - EMI spectrum has been tested and approved
 - Built-in coil suppression
- Hermetically Sealed contact chamber to protect all moving parts
- Able to handle harsh environments
- Provided with sealed control wire connector



Nomenclature

Example

AEVT350 —

B

A

Series code:

“AEVT350” =AEVT350 Series

Coil Voltage Code:

“B” = 12VDC

“C” =24VDC

Options:

Blank = Std. Options (Bottom Mount, Without Aux. Contact & Polarized Load Terminals)

“A” = With Aux. Contact (SPST-NO)

AEVT350 Series DC Contactor Specification

Performance Data

MAIN CONTACT	LIFE	DATA	
Contact arrangement	1 Form X (SPST-NO DM)	350A @ 450VDC (make/break)	3,000 cycles
Rated Operating Voltage	12-1,800VDC	350A @ 650VDC (make/break)	1,000 cycles
Continuous (Carry) Current	350A ¹	Mechanical life	200,000 cycles
Short term Carry Current	400A (6.5 minutes) ²	AUX. CONTACT	
Max short circuit current	2,300A @ 450VDC (1 cycle)	Aux. Contact Arrangement	SPST-NO (1 Form A)
Dielectric Withstanding Voltage	Between open contacts: 4,000VDC (leakage ≤ 1mA)	Aux. Contact Rating (Max Wattage)	10W
	Between contact and coil: 2,200Vrms (leakage ≤ 1mA)	Aux. Contact Rating (Max Voltage)	100 VDC
Insulation Resistance	Terminal to Terminal / Terminal to Coil	Aux. Contact Resistance (Max)	500mΩ
	New: Min 100MΩ @500VDC		
Voltage Drop (@350A)	≤120mV		
ENVIRONMENTAL DATA		OPERATE / RELEASE TIME	
Shock, 11ms ½ sine, operating	20G Peak	Close (includes bounce)	18ms, Max.
Vibration, Sine, Peak, 20G	10–1,000Hz	Bounce (after close)	5ms, Max.
Operating Ambient Temperature	-40 to +85°C	Release	15ms, Max.
Noise (@100mm)	70dB(a)		
Altitude	<4000m		
Weight	1.76 lb (0.8 kg)		
COIL DATA			
Voltage rating		12Vdc	24Vdc
Pickup voltage (25 °C)		10Vdc	19Vdc
Dropout voltage (25 °C)		4Vdc	9Vdc
Inrush current @ nominal voltage		2.8A	1.8A
Holding current @ nominal voltage		0.40A	0.11A

Note:

*1: Current is relevant to cross-sectional area of conductor.

*2: Ambient Temperature +65°C

AEVT350 Series DC Contactor Specification

Contact Rating

Estimated Make & Break Resistive Load Ratings

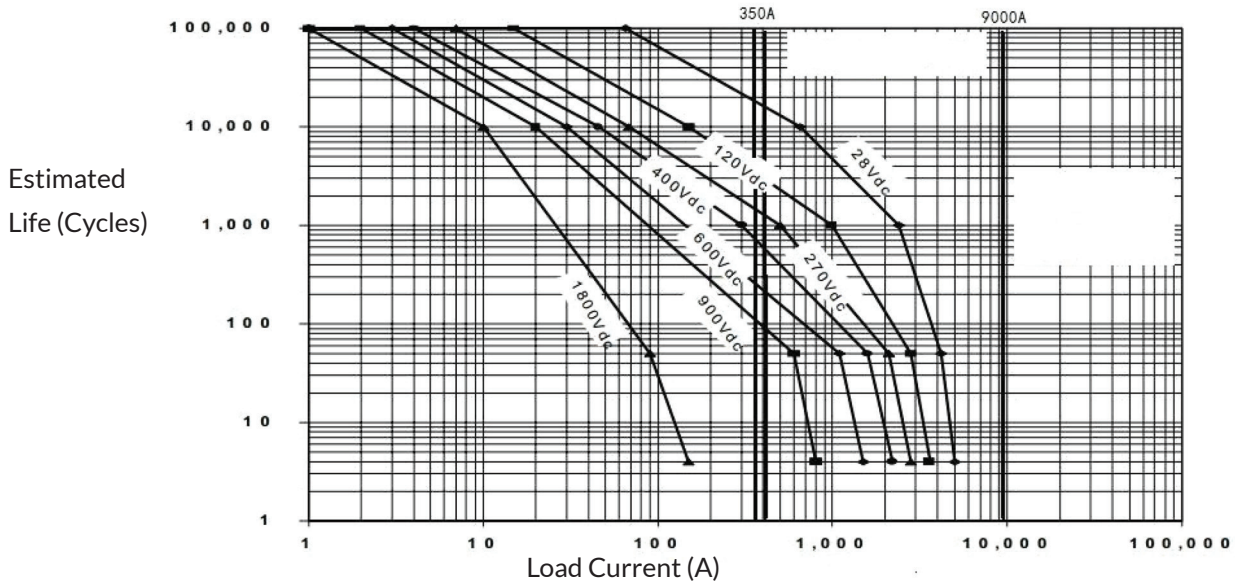

Note:

Test run under controlled conditions. User to verify in actual application.

AEVT350 Capacitive Make Test Curves for Pre-Charged Motor Controller

CURRENT-TIME CURVE

Contact operate @70% and 90% capacitive pre-charge

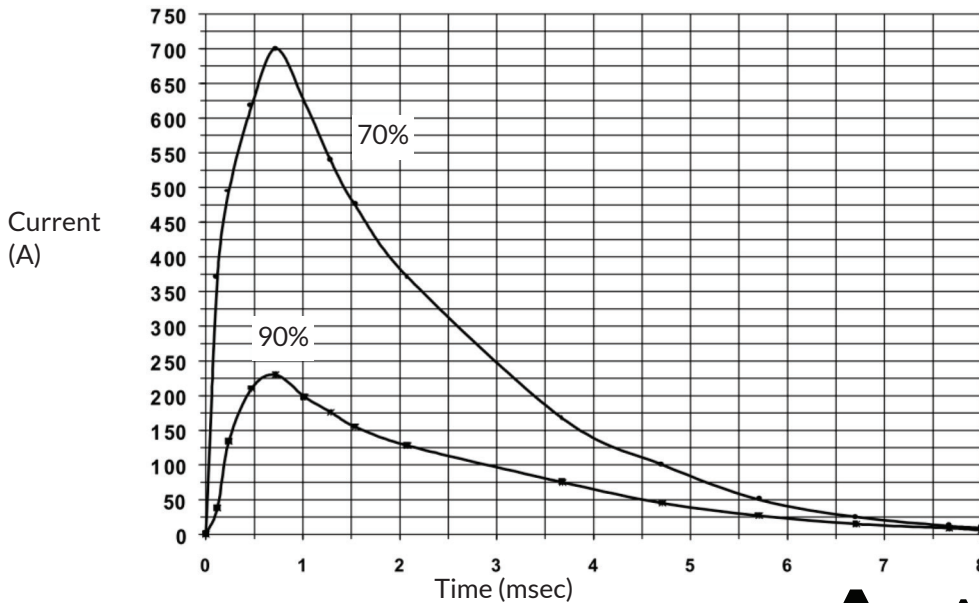

AEVT350 Series DC Contactor Specification

Outline Dimensions: inches (mm)

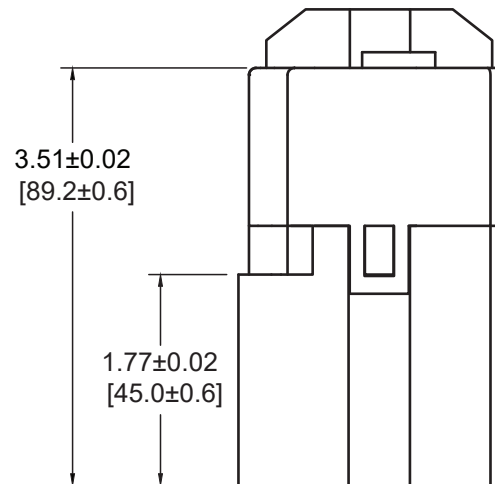
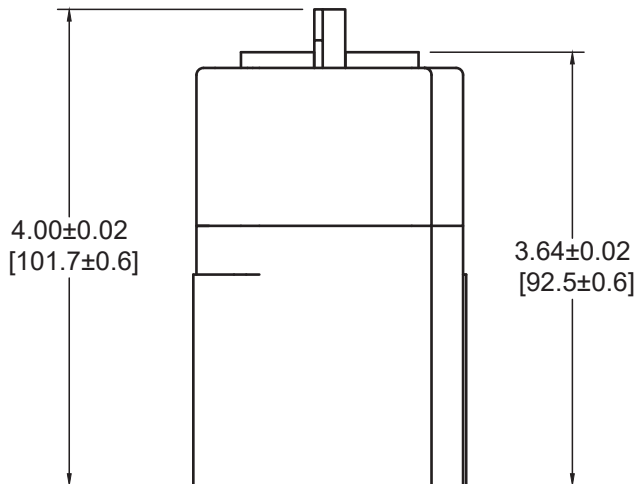
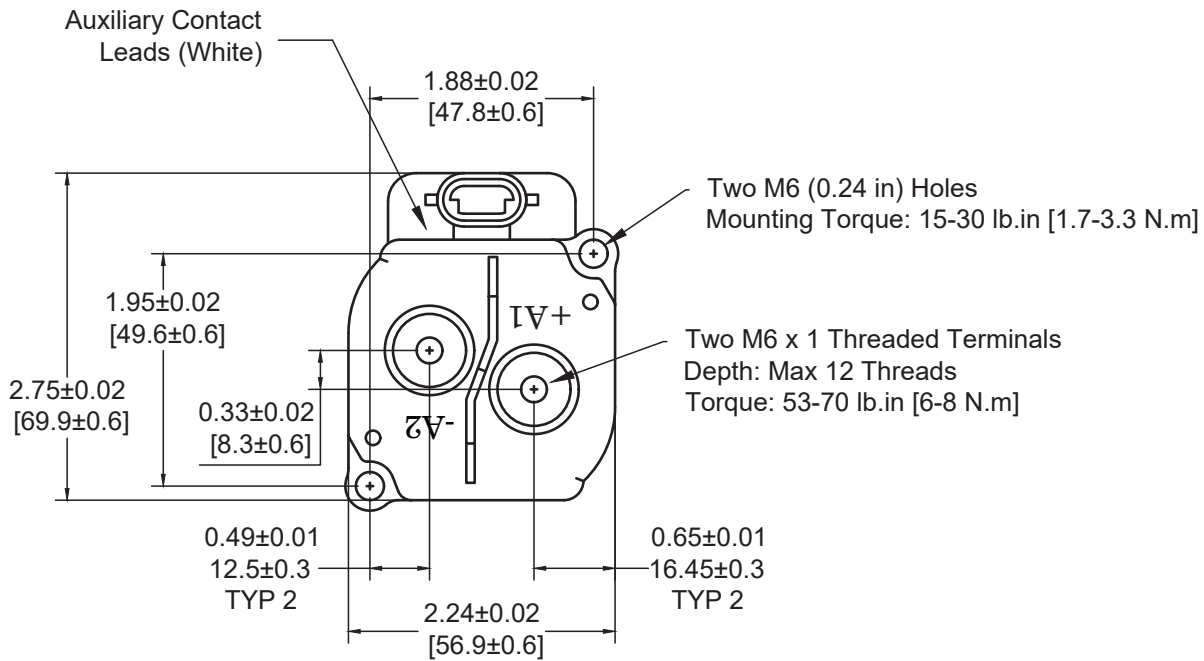

AEVT350 Series DC Contactor Specification

Application Note:

1. Be sure to use washer to prevent screws from loosening, all the terminals or copper bar must be in direct contact with the contactor's terminals.
 - Contact Terminal Torque: 53 - 70 lb.in (6 - 8 N.m)
 - Mounting Torque: 15 - 30 lb.in (1.7 - 3.3 N.m)
2. Contact terminals are polarized so refer to drawing during connecting. There is a reverse surge absorption circuit so that it is not necessary to use a surge protective device.
3. Do not use if dropped.
4. Avoid installing in a strong magnetic field (close to a transformer or magnet), or near a heat source.
5. Electrical life
Use per load capability and life cycle limits so as not to cause a function failure (treat the contactor as a product with specified life and replace it when necessary). It is possible to make parts burn around the contactor once operating failure occurs. It is necessary to take layout considerations into account and to make sure power shall be cut off within 1 second.
6. Avoid debris or oil contamination of the main terminals to optimize contact and avoid excess heat generation.